

PRODUCT NUMBER
 69168-XYZHLF

- LEAD FREE OPTION
SEE NOTE 7, 8, 9
- CUSTOMER SPECIALS
SEE NOTE 6
- NO. OF POS.
SEE TABLE
- PIN PLATING
- BASE P/N

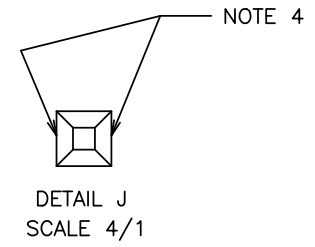

□ .025/.64 PIN
 TYPE
 Ⓢ .020/0.51 (M) A (S) B (S)
 AT TIPS
 BOTH ENDS

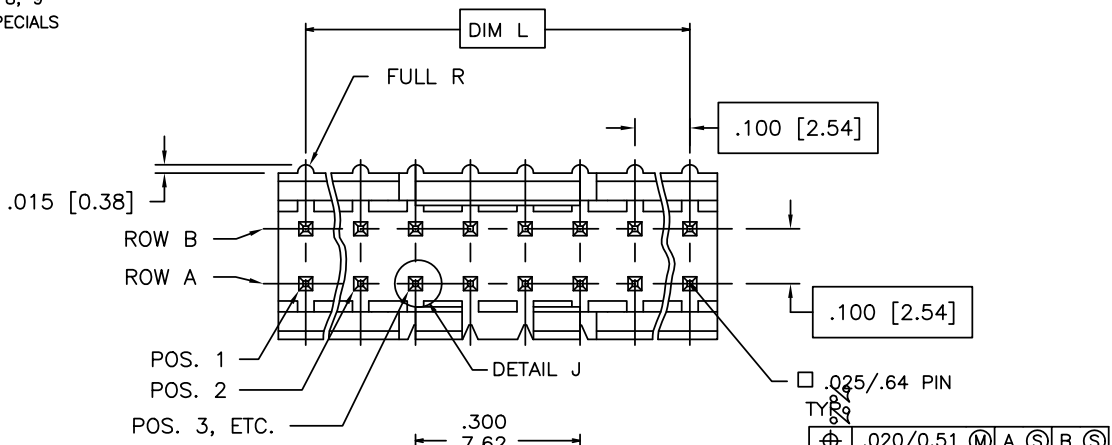
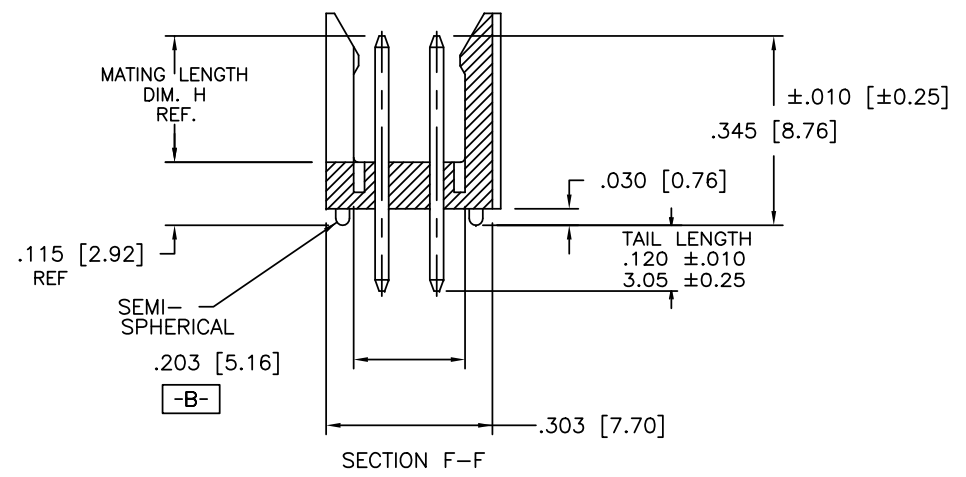
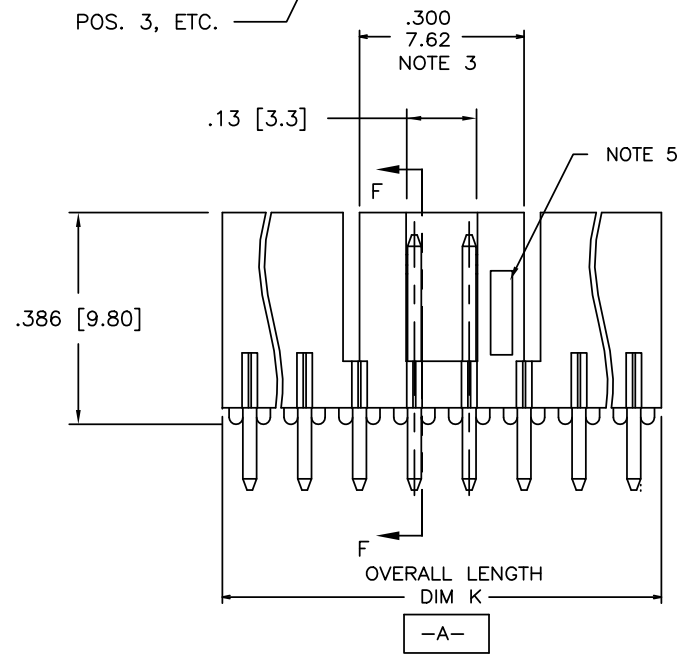

FCIconnect.com

Copyright FCI

mat'l. code		surface ISO 1302 ✓		tolerance ISO 406 ISO 1101		projection INCH/MM		product family HEADER	
ltr ecn nldr date		tolerances unless otherwise specified		title		scale 3:1		FRICION LATCH HEADER DOUBLE ROW VERTICAL	
M	EX-N-011899	JZ	2012-05-31	angles	linear	XXX±.01/XXX±.03		dwg no 69168 sheet of 2 size A3	
G	V03-0352	GJP	03/25/03	0°±2'		XXX±.005/XXX±.013		type Product Customer Drawing	
H	M05-0134	ERE	06/15/05	dr	L.SADERS	5/3/95			
J	M06-0256	MHT	9/07/06	engr	L.FYE	5/3/95			
K	M08-0023	MHT	1/28/08	chr	T.BREWBAKER	5/3/95			
L	M08-0291	MHT	10/06/08	appd	L.FYE	5/3/95			
sheet	revision	M	M						
index	sheet	1	2						

PRODUCT NUMBER	NO.OF POS.	MATING LENGTH DIM H	OVERALL LENGTH DIM K	DIM L	NOTES
69168-X06	2 X 3	0.230/5.84	0.300/7.62	0.200/5.08	
-X08	2 X 4	0.230/5.84	0.400/10.16	0.300/7.62	
-X08A	2 X 4	0.210/5.33	0.400/10.16	0.300/7.62	NOTE 6
-X10	2 X 5	0.230/5.84	0.500/12.70	0.400/10.16	
-X10A	2 X 5	0.210/5.33	0.500/12.70	0.400/10.16	NOTE 6
-X12	2 X 6	0.230/5.84	0.600/15.24	0.500/12.70	
-X14	2 X 7	0.230/5.84	0.700/17.78	0.600/15.24	
-X16	2 X 8	0.230/5.84	0.800/20.32	0.700/17.78	
-X16A	2 X 8	0.210/5.33	0.800/20.32	0.700/17.78	NOTE 6
-X18	2 X 9	0.230/5.84	0.900/22.86	0.800/20.32	
-X18A	2 X 9	0.210/5.33	0.900/22.86	0.800/20.32	NOTE 6
-X20	2 X 10	0.230/5.84	1.000/25.40	0.900/22.86	
-X22	2 X 11	0.230/5.84	1.100/27.94	1.000/25.40	
-X24	2 X 12	0.230/5.84	1.200/30.48	1.100/27.94	
-X26	2 X 13	0.230/5.84	1.300/33.02	1.200/30.48	
-X28	2 X 14	0.230/5.84	1.400/35.56	1.300/33.02	
69168-X30	2 X 15	0.230/5.84	1.500/38.10	1.400/35.56	

NOTES:

- MOLDING MAT'L: GLASS REINFORCED PCT, COLOR: BLACK
FLAME RETARDANT PER UL 94 V-0
MAXIMUM OPERATING TEMPERATURE: 130° C
OR
MINERAL FILLED LCP, COLOR BLACK
FLAME RETARDANT PER UL 94 V-0
- PIN MATERIAL: 3/4 HD PHOS. BRZ.
- NO SLOTS ON 2 X 5 POSITION OR SMALLER PRODUCT. THE CENTER KEY SLOT WILL BE ON ALL HEADERS REGARDLESS OF SIZE.
- TWO NON-CRITICAL SIDES OF PIN TIP NOT PLATED, BOTH ENDS.
- COMPANY LOGO MAY APPEAR IN THIS AREA.
- CUSTOMER SPECIAL -- "A" SUFFIX INDICATES 0.210/5.33 MATING LENGTH.
- ADD "HLF" SUFFIX AT THE END OF PART NUMBER FOR LEAD FREE OPTION, NOT AVAILABLE FOR -5YY, -5YYH, -6YY & -6YYH.
- PART NUMBERS WITH "H" SUFFIX WILL WITHSTAND EXPOSURE TO 260°C PEAK TEMPERATURE FOR 20 SECONDS IN WAVE SOLDER, INFRA-RED OR VAPOR PHASE SOLDER PROCESS.

PART NUMBERS WITHOUT "H" SUFFIX WILL WITHSTAND EXPOSURE TO 260°C PEAK TEMPERATURE FOR WAVE SOLDER PROCESS.
- THIS PRODUCT MEETS EUROPEAN UNION DIRECTIVES AND OTHER COUNTRY REGULATION AS DESCRIBED IN GS-22-008.
- PLATING OPTIONS:
PERFORMANCE PLATING WILL BE EITHER GOLD OR GXT ON CONTACT OR TAIL, OPTIONALLY (78~295u"/2~7.5u) TIN ON TAIL.
- "THIS PRODUCT HAS 100% TIN PLATING IN THE INTERFACE AND HAS NOT BEEN TESTED FOR WHISKER GROWTH IN ALL INTERCONNECT ENVIRONMENTS."

PIN PLATING CODES

-1YY	30u"/.76u (SEE NOTE 10) 50u"/1.27u Ni
-2YY	15u/.38u (SEE NOTE 10) 50u"/1.27u Ni
-3YY	50u"/1.27u (SEE NOTE 10) 50u"/1.27u Ni
-4YY	100u"/2.54u MIN Sn 50u"/1.27u Ni (SEE NOTE 11)
-4YYHLF	
-5YY	15u"/.38u (SEE NOTE 10) 50u"/1.27u Ni
-6YY	30u"/.76u (SEE NOTE 10) 50u"/1.27u Ni
-7YY	30u"/.76u (SEE NOTE 10) OVER 50u"/1.27u Ni
-8YY	15u"/.38u (SEE NOTE 10) OVER 50u"/1.27u Ni

mat'l. code	surface ISO 1302 ✓	tolerance ISO 406 ISO 1101	projection 	product family HEADER
ltr ecn nldr date	tolerances unless otherwise specified			title FRICTION LATCH HEADER DOUBLE ROW VERTICAL
M	angles	linea	INCH/MM	scale 3:1
	0±2'			
dr	L.SADERS	5/3/95		dwg no 69168
engr	L.FYE	5/3/95		sheet 2 of 2 size A3
chr	T.BREWBAKER	5/3/95		
appd	L.FYE	5/3/95		type Product Customer Drawing
sheet index	revision sheet			