

 ELECTRONICS

# AirMax VS<sup>®</sup> and ZipLine<sup>®</sup> High Speed Connector Systems



## FCI: SETTING THE STANDARD FOR CONNECTORS

With operations in 30 countries, FCI is a leading manufacturer of connectors. Our 13,500 employees are committed to providing customers with high-quality, innovative products for a wide range of consumer and industrial applications.

### LIABILITY

We believe that the information contained in this publication is the best currently available on the subject. It is offered as a possible helpful suggestion in any experimentation you may care to undertake and is subject to revision as additional knowledge and experience is gained. FCI makes no guarantee of results and assumes no obligation or liability whatsoever in connection with this information. This publication is not a license to operate under, or intended to suggest infringement of, any existing patent. Information given on the drawings in this document is not suitable for tooling design and construction. To obtain the correct drawings for these purposes, contact your local FCI representative.



	page
<b>Introduction</b> .....	4-5
<b>Backplane Applications</b>	
AirMax VS® Family .....	6
ZipLine® Family .....	7
Product Finder .....	8-11
<b>Orthogonal Midplane Applications</b>	
AirMax VS® Family .....	12
ZipLine® Family .....	13
<b>Coplanar Applications</b>	
AirMax VS® Family .....	14
ZipLine® Family .....	15
Product Finder .....	16-17
<b>Mezzanine Applications</b>	
AirMax VS® Family .....	18
<b>Cable-to-Board Applications</b>	
AirMax VS® Family .....	19
<b>Guide Modules</b> .....	20-21
<b>Power Connectors</b>	
Hard Metric High Power Modules .....	22-23
HCI® High Power Modules .....	24
<b>Appendices</b>	
Industry Specifications	
Storage Bridge Bay (SSB) .....	26-27
Intel® Quick Path Interconnect (Intel® QPI) .....	28-29
Server System Infrastructure (SSI) Blade Server .....	30-31
Routing Examples .....	32-33
Application Tooling .....	34-35
Additional Resources .....	36-37
<b>Part Number index</b> .....	38-39

## AIRMAX VS® and ZIPLINE® HIGH-PERFORMANCE CONNECTOR SYSTEM

In 2003 FCI introduced the AirMax VS® connectors, the first high-performance connector system to use a shield-less design with an air dielectric between conductors. This innovative technology delivers signal densities up to 63.5 differential pairs per inch while exhibiting low insertion loss and low crosstalk, allowing systems to scale differential signals up to 12.5Gb/s. In 2007, the ZipLine® connector system leveraged this proven high-speed, shield-less technology to achieve a new milestone in signal density, 84.6 differential pairs per inch.

Breaking the dependence on metal shields to accomplish excellent high-speed electrical performance also provides incredible design flexibility. Individual contacts in a connector module are able to be allocated to differential signal pairs, single-ended signals or low-level power as dictated by the system need. In addition, column spacing can be easily increased to enable more signal traces to be routed on a board layer, trading some signal density for reduced layer count and lower board cost for those applications that do not demand maximum signal density. The AirMax VS system also provides flexibility in the number of differential pairs per column to address card slot pitch, connector profile or airflow requirements.

As a result of numerous product extensions and new product developments to address customer demand, the AirMax VS and ZipLine connector offerings now include a broad range of backplane, midplane, coplanar, mezzanine, cable-to-board, and orthogonal midplane connector configurations.

Together, the AirMax VS and ZipLine connector systems provide the most comprehensive range of high-speed, lightweight, flexible, and scalable connectors available today - ideal for a broad range of applications in Data, Communications, and Industrial equipment.

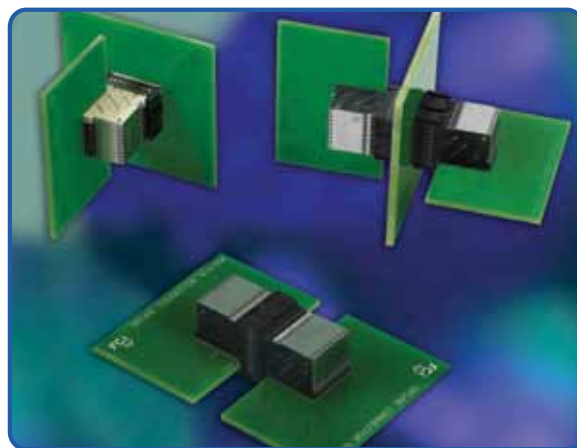
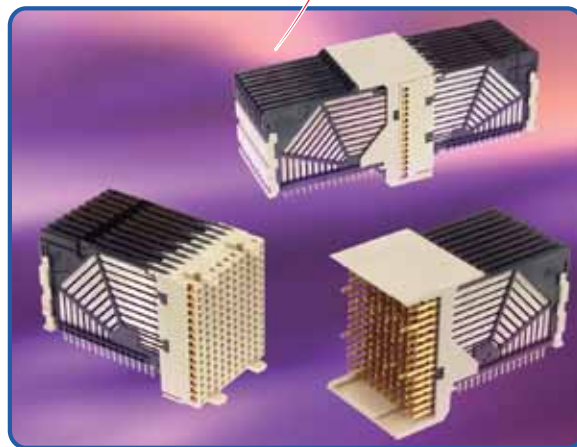

**ZipLine®**

### MARKETS & APPLICATIONS

#### DATA

- ▶ Rack-Mount Servers
- ▶ Blade Servers
- ▶ External Storage Systems

#### COMMUNICATIONS

- ▶ Switches
- ▶ Routers
- ▶ Wireless Base Stations
- ▶ Network Access/Aggregation
- ▶ Transport

#### INDUSTRIAL

- ▶ Medical
- ▶ Test & Measurement

### INDUSTRY SPECIFICATIONS

- ▶ Storage Bridge Bay (SBB)
- ▶ Intel® Quick Path Interconnect (Intel® QPI)
- ▶ Server System Infrastructure (SSI) Blade Server

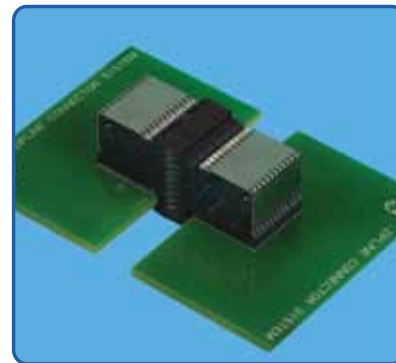
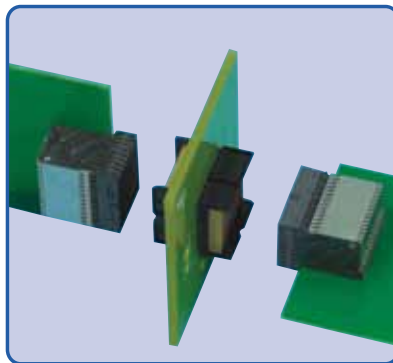
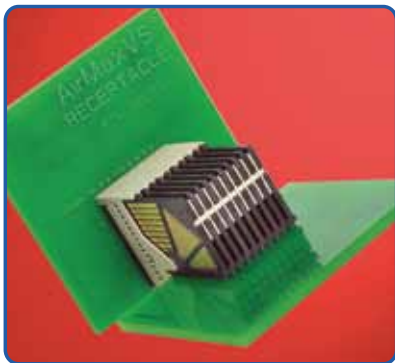

## FEATURES & BENEFITS

- ▶ Enable backplane, midplane, orthogonal midplane, coplanar, mezzanine, and cable-to-board applications
- ▶ A full set building blocks compatible with Hard Metric equipment practice
- ▶ Innovative shield-less design delivers low loss and crosstalk
- ▶ Support high-speed differential signaling at data rates up to 12.5 Gb/s
- ▶ Opposed dual-beam receptacle contact structure provides high reliability
- ▶ Qualification to Telcordia® GR-1217-CORE Central Office requirements
- ▶ Elimination of interleaving shields reduces connector weight, cost, and PCB routing complexity
- ▶ Flexibility to assign contacts to differential or single-ended signals or low-level power within a module
- ▶ AirMax VS signal modules are available with 15 contacts (5 differential pairs), 12 contacts (4 pairs), or 9 contacts (3 pairs) per column meeting a wide range of application needs
  - ▶ 2mm pitch, 5-pair configuration provides 63.5 differential pairs/inch within a 25mm card slot
  - ▶ 3 mm column pitch enables more traces/layer for potential reduction in layer count and PCB cost
- ▶ ZipLine signal modules with 18 contacts (6 differential pairs) per column provide 84.6 differential pairs/inch within a 27mm card slot for even more density
- ▶ Orthogonal midplane systems provide up to 72 differential pair crossovers in a single connector for the highest density in the industry
- ▶ AirMax VS 85-ohm connector versions are optimized for use in 85-ohm channels, such as Intel® QPI links
  - ▶ Support right-angle or coplanar connections
  - ▶ Backward compatible to legacy 100-ohm product interfaces
- ▶ Complementary power connectors are available for use alongside signal modules
  - ▶ Compact Hard Metric high power modules rated for up to 20A or 40A per contact
  - ▶ HCI® high-power modules rated for up to 83A per power contact
- ▶ “Eye of the Needle” (EON) compliant tail for press-fit PCB termination
- ▶ Lead-free and RoHS-compatible

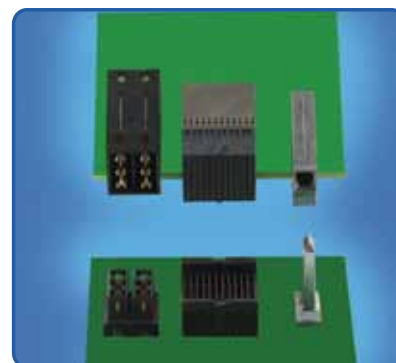
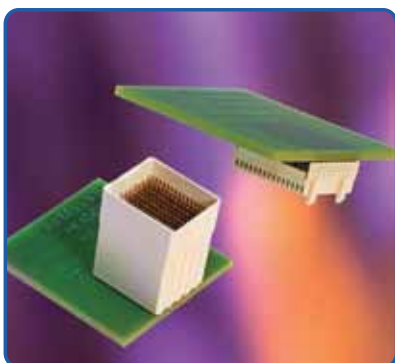

## AIRMAX VS® BACKPLANE / MIDPLANE CONNECTORS

### FEATURES

- Provides options for the protected receptacle to be on the backplane/midplane or on the daughter card at the designer's discretion
- Available range of differential pairs/column, column pitches, and column counts offers design flexibility
- Designs optimized for either 100Ω or 85Ω impedance to match channel impedance and reduce loss
- Halogen-free signal modules aid efforts to minimize the use of environmentally sensitive materials
- Available power and guide modules complement signal connector offering

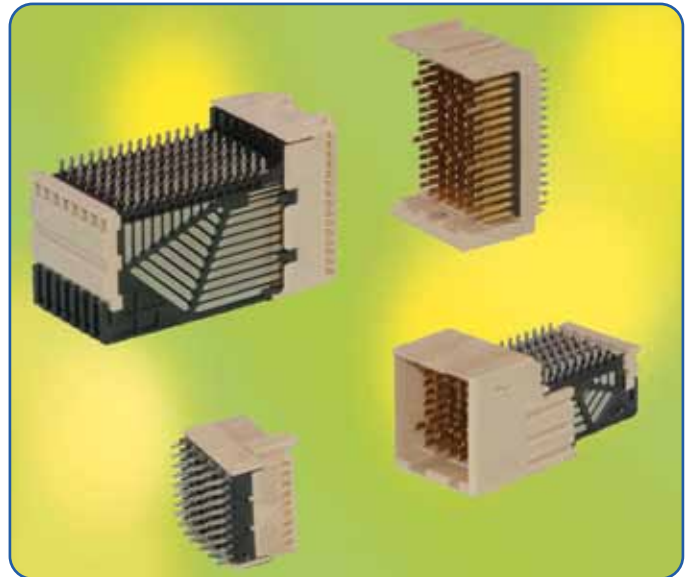

### TECHNICAL DATA

#### MATERIALS

- Contacts: Copper alloy
- Contact finish
  - Performance-based plating over nickel at separable interface
  - Tin over nickel on press-fit tails on standard lead-free products. Tin-lead option available upon request.
- Housings: High-temperature thermoplastic, UL 94V-0

#### MECHANICAL PERFORMANCE

- Durability: 200 cycles
- Mating force: 0.45N maximum/contact
- Unmating force: 0.15N minimum/contact
- Compliant pin insertion force:
  - Vertical headers, right-angle headers or right-angle receptacles: 40N maximum
  - Vertical receptacles: 25N maximum

#### SPECIFICATIONS

- Product specification: GS-12-239
- Application specification: GS-20-035

#### APPROVALS AND CERTIFICATIONS

- Telcordia GR-1217-CORE Central Office

#### PACKAGING

- Tubes
- Trays (vertical receptacle only)

#### ELECTRICAL PERFORMANCE

- Contact resistance:  $\leq 35 \text{ m}\Omega$  initial,  $\leq 10 \text{ m}\Omega$  increase after environmental test
- Current rating ( $\leq 30^\circ\text{C}$  rise above ambient in still air): 0.5A/contact with all contacts powered

#### 100Ω Connectors

- Differential impedance:  $100 \pm 8\Omega$  @ 50 ps (10-90%) rise time
- Differential insertion loss:  $< 1 \text{ dB}$  through 6.25 Gb/s  $< 1.5 \text{ dB}$  through 12.5 Gb/s
- Near-end crosstalk (multi-active):  $< -38 \text{ dB}$  through 6.25 Gb/s;  $< -28 \text{ dB}$  through 12.5 Gb/s
- Far-end crosstalk (multi-active):  $< -41 \text{ dB}$  through 6.25 Gb/s;  $< -28 \text{ dB}$  through 12.5 Gb/s

#### 85Ω Connectors

- Differential impedance:  $85 \pm 5\Omega$  @ 50 ps (10-90%) risetime
- Differential insertion loss:  $< 1.5 \text{ dB}$  through 8 Gb/s
- Near-end crosstalk (multi-active):  $< -30 \text{ dB}$  through 8 Gb/s
- Far-end crosstalk (multi-active):  $< -30 \text{ dB}$  through 8 Gb/s

## ZIPLINE® BACKPLANE / MIDPLANE CONNECTORS

### FEATURES

- Modules with 6 differential pairs/column provide maximum linear signal density along card edge: 84.6 differential pairs per inch
- An optional power wafer with up to 36A capacity can be integrated within a 6-pair module
- Stainless steel organizer allows use of flat-rock tooling for connector installation
- Halogen-free signal modules aid efforts to minimize the use of environmentally sensitive materials
- Available power and guide modules complement signal connector offering

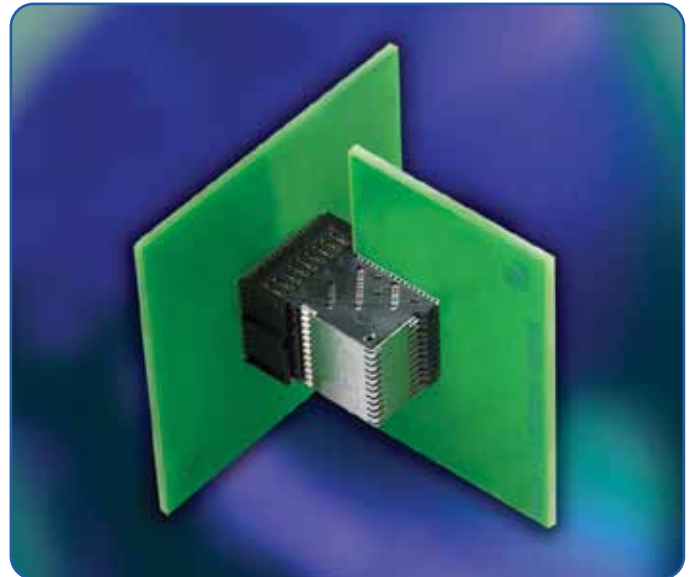

### TECHNICAL DATA

#### MATERIALS

- Contacts: Copper alloy
- Contact finish
  - Performance-based plating over nickel at separable interface
  - Tin over nickel on press-fit tails on standard lead-free products. Tin-lead option available upon request.
- Housings: High-temperature thermoplastic, UL 94V-0
- Organizer: Stainless steel

#### MECHANICAL PERFORMANCE

- Durability: 200 cycles
- Mating force: 0.40N maximum/contact
- Unmating force: 0.10N minimum/contact
- Compliant pin insertion force: 25N maximum

#### SPECIFICATIONS

- Product specification: GS-12-452
- Application specification: GS-20-094

#### APPROVALS AND CERTIFICATIONS

- Telcordia GR-1217-CORE Central Office

#### PACKAGING

- Tubes

#### ELECTRICAL PERFORMANCE

- Contact resistance:
  - Signal contact:  $\leq 130 \text{ m}\Omega$  initial,  $\leq 10 \text{ m}\Omega$  increase after environmental test
  - Power contact:  $\leq 5 \text{ m}\Omega$  initially and after environmental test
- Current rating ( $\leq 30^\circ\text{C}$  rise above ambient in still air)
  - Signal contact: 0.25A/contact with all contacts powered
  - Power contact: (6-contacts/column):
    - 6A /contact (1 column powered)
    - 4.5A/contact (2 columns powered)
    - 2.25A/contact (12 columns powered)
- Differential impedance:  $100 \pm 7\Omega$  @ 100 ps (10-90%) risetime
- Differential insertion loss:  $< 1 \text{ dB}$  through 6.25 Gb/s;  $< 2.5 \text{ dB}$  through 12.5 Gb/s
- Near-end crosstalk (multi-active):  $< -34 \text{ dB}$  through 6.25 Gb/s;  $< -28 \text{ dB}$  through 12.5 Gb/s
- Far-end crosstalk (multi-active):  $< -38 \text{ dB}$  through 6.25 Gb/s;  $< -26 \text{ dB}$  through 12.5 Gb/s

## AIRMAX VS® SIGNAL MODULES with vertical receptacle

### TYPICAL APPLICATIONS & SIGNAL DENSITY

Minimum Card Slot Spacing (mm)	column pitch (mm)	Differential Pairs				Contacts				Product Family
		per column	Linear Density		per column	Linear Density				
			per inch	per cm		per inch	per cm			
25	2.0	5	63.5	25.0	15	190.5	75	AirMax VS		
25	3.0	5	42.3	16.7	15	127.0	50	AirMax VS		
20	2.0	4	50.8	20.0	12	152.4	60	AirMax VS		
20	3.0	4	33.9	13.3	12	101.6	40	AirMax VS		
17	2.0	3	38.1	15.0	9	114.3	45	AirMax VS		

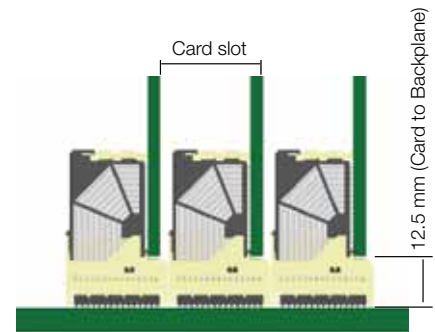

### AIRMAX VS® SIGNAL MODULES with vertical receptacle

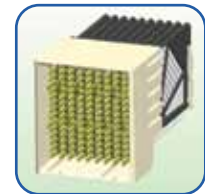

Differential Impedance (ohms)	Minimum Card Slot Spacing (mm)	Differential Pairs		Total Contacts	Number of Columns	Column Pitch (mm)	Header Type	Module Width Along Card Edge (mm)	Signal Module Part Numbers	
		Total	Per Column						Backplane/Midplane	Daughter Card
									Vertical Receptacle	Right-Angle Header
85	25	50	5	150	10	2.0	4-wall	22.0	10099767-101LF	10097311-101LF
85	25	50	5	150	10	3.0	4-wall	32.0	10099768-101LF	10087771-101LF
85	17	18	3	54	6	2.0	4-wall	14.0	10096461-101LF	10097256-101LF
100	25	50	5	150	10	2.0	2-wall	20.0	10016537-101LF	10016527-101LF
100	25	50	5	150	10	2.0	4-wall	22.0	10016537-101LF	10025613-101LF
100	25	50	5	150	10	3.0	2-wall	30.0	10035146-101LF	10037323-101LF
100	25	50	5	150	10	3.0	4-wall	32.0	10035146-101LF	10037324-101LF
100	25	40	5	120	8	2.0	2-wall	16.0	10040993-101LF	10041746-101LF
100	25	40	5	120	8	2.0	4-wall	18.0	10040993-101LF	10041460-101LF
100	25	40	5	120	8	3.0	2-wall	24.0	10064493-101LF	10064488-101LF
100	25	40	5	120	8	3.0	4-wall	26.0	10064493-101LF	10064489-101LF
100	20	40	4	120	10	2.0	2-wall	20.0	10028264-101LF	10029391-101LF
100	20	40	4	120	10	2.0	4-wall	22.0	10028264-101LF	10028436-101LF
100	20	40	4	120	10	3.0	2-wall	30.0	10035465-101LF	10035514-101LF
100	20	40	4	120	10	3.0	4-wall	32.0	10035465-101LF	10035515-101LF
100	20	32	4	96	8	2.0	2-wall	16.0	10052842-101LF	10052837-101LF
100	20	32	4	96	8	2.0	4-wall	18.0	10052842-101LF	10052838-101LF
100	20	24	4	72	6	2.0	2-wall	12.0	10052829-101LF	10052824-101LF
100	20	24	4	72	6	2.0	4-wall	14.0	10052829-101LF	10052825-101LF
100	17	30	3	90	10	2.0	2-wall	20.0	10034251-101LF	10034264-101LF
100	17	30	3	90	10	2.0	4-wall	22.0	10034251-101LF	10034249-101LF
100	17	24	3	72	8	2.0	2-wall	16.0	10045271-101LF	10045266-101LF
100	17	24	3	72	8	2.0	4-wall	18.0	10045271-101LF	10045267-101LF
100	17	18	3	54	6	2.0	2-wall	12.0	10043546-101LF	10040862-101LF
100	17	18	3	54	6	2.0	4-wall	14.0	10043546-101LF	10039851-101LF

■ Listed part numbers designate the standard lead-free offering. Contact FCI to request options with tin-lead finish in termination areas.



## AIRMAX VS® & ZIPLINE® SIGNAL MODULES with vertical header

### TYPICAL APPLICATIONS & SIGNAL DENSITY

Minimum Card Slot Spacing (mm)	column pitch (mm)	Differential Pairs			Contacts			Product Family
		per column	Linear Density per inch	per cm	per column	Linear Density per inch	per cm	
27	1.8	6	84.6	33.3	18	254.0	100	ZipLine
27	2.0	5	63.5	25.0	15	190.5	75	AirMax VS
27	3.0	5	42.3	16.7	15	127.0	50	AirMax VS
23	2.0	4	50.8	20.0	12	152.4	60	AirMax VS
23	3.0	4	33.9	13.3	12	101.6	40	AirMax VS
19	2.0	3	38.1	15.0	9	114.3	45	AirMax VS

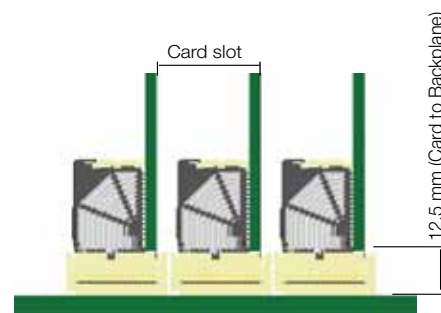

### AIRMAX VS® SIGNAL MODULES with vertical header



Differential Impedance (ohms)	Minimum Card Slot Spacing (mm)	Differential Pairs		Total Contacts	Number of Columns	Column Pitch (mm)	Header Type	Module Width Along Card Edge (mm)	Signal Module Part Numbers		
		Total	Per Column						Backplane/Midplane		Daughter Card
									Vertical Header	Right-Angle Receptacle	
85	27	50	5	150	10	2.0	2-wall	20.0	10095500-1050011LF	10095504-101LF	
85	27	50	5	150	10	3.0	2-wall	30.0	10073377-1050011LF	10095505-101LF	
100	27	50	5	150	10	2.0	2-wall	20.0	10056098-1050011LF	10034475-101LF	
100	27	50	5	150	10	3.0	2-wall	30.0	10056427-1050011LF	10057041-101LF	
100	27	40	5	120	8	2.0	2-wall	16.0	10055140-1050011LF	10045548-101LF	
100	23	40	4	120	10	2.0	2-wall	20.0	10056100-1050011LF	10035754-101LF	
100	23	40	4	120	10	2.0	4-wall	22.0	10056100-1080011LF	10035754-101LF	
100	23	40	4	120	10	3.0	2-wall	30.0	10056430-1050011LF	10045722-101LF	
100	23	40	4	120	10	3.0	4-wall	32.0	10056430-1080011LF	10045722-101LF	
100	23	32	4	96	8	2.0	2-wall	16.0	10055307-1050011LF	10060905-101LF	
100	23	32	4	96	8	3.0	2-wall	24.0	10056429-1050011LF	10076645-101LF	
100	19	30	3	90	10	2.0	2-wall	20.0	10056103-1050011LF	10056335-101LF	
100	19	30	3	90	10	2.0	4-wall	22.0	10056103-1080011LF	10056335-101LF	
100	19	18	3	54	6	2.0	2-wall	12.0	10056101-1050011LF	10053656-101LF	

### ZIPLINE® SIGNAL MODULES with vertical header



Differential Impedance (ohms)	Minimum Card Slot Spacing (mm)	Differential Pairs		Total Contacts	Number of Columns	Column Pitch (mm)	Header Type	Module Width Along Card Edge (mm)	Signal Module Part Numbers		
		Total	Per Column						Backplane/Midplane		Daughter Card
									Vertical Header	Right-Angle Receptacle	
100	27	96	6	288	16	1.8	2-wall	28.8	10084186-101LF	10084155-101LF	
100	27	72	6	216	12	1.8	2-wall	21.6	10076197-101LF	10076209-101LF	
100	27	72	6	216	12	1.8	4-wall	21.6	10080638-101LF	10076209-101LF	
100	27	66	6	198	11	1.8	2-wall	21.6	10084166-101LF	10084164-101LF	
100	27	60	6	180	10	1.8	2-wall	21.6	10084166-103LF	10084164-102LF	
100	27	36	6	108	6	3.6	2-wall	21.6	10078557-101LF	10078550-101LF	

■ Note: The Total Contacts and Number of Columns shown represent signal contacts. The ZipLine module with 66 differential pairs also includes an additional column containing a power wafer. The ZipLine module with 60 differential pairs also includes two power wafers.

■ Listed part numbers designate the standard lead-free offering. Contact FCI to request options with tin-lead finish in termination areas.

## HARD METRIC BACKPLANE/MIDPLANE POWER CONNECTORS

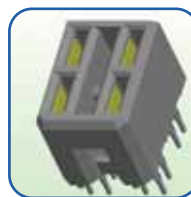

Minimum Card Slot Spacing (mm)	Contacts		Current Rating		Number of Columns	Column Pitch (mm)	Module Width Along Card Edge (mm)	Power Module Part Numbers	
	Total	Per Column	Amps per Contact	Amps per Module				Backplane/Midplane	Daughter Card
								Vertical Receptacle	Right-Angle Header
20	2	1	40	80	2	6.0	12.0	10028916-4444P00LF	10028918-001LF
20	2	1	40	80	2	6.0	12.0	10028916-4554P00LF	10028918-001LF
20	2	1	40	80	2	6.0	12.0	10028916-5555P00LF	10028918-001LF
20	4	2	20	80	2	6.0	12.0	10028916-4444P00LF	10028917-001LF
20	4	2	20	80	2	6.0	12.0	10028916-4455P00LF	10028917-001LF
20	4	2	20	80	2	6.0	12.0	10028916-4554P00LF	10028917-001LF
20	4	2	20	80	2	6.0	12.0	10028916-4555P00LF	10028917-001LF
20	4	2	20	80	2	6.0	12.0	10028916-5554P00LF	10028917-001LF
20	4	2	20	80	2	6.0	12.0	10028916-5555P00LF	10028917-001LF
17	4	2	20	80	2	6.0	12.0	10028916-4444P00LF	10073379-001LF
17	4	2	20	80	2	6.0	12.0	10028916-4455P00LF	10073379-001LF
17	4	2	20	80	2	6.0	12.0	10028916-4554P00LF	10073379-001LF
17	4	2	20	80	2	6.0	12.0	10028916-4555P00LF	10073379-001LF
17	4	2	20	80	2	6.0	12.0	10028916-5554P00LF	10073379-001LF
17	4	2	20	80	2	6.0	12.0	10028916-5555P00LF	10073379-001LF
17	6	2	20	120	3	6.0	18.0	10061290-554555PLF	10061289-001LF
17	6	2	20	120	3	6.0	18.0	10061290-555444PLF	10061289-001LF
17	6	2	20	120	3	6.0	18.0	10061290-545555PLF	10061289-001LF

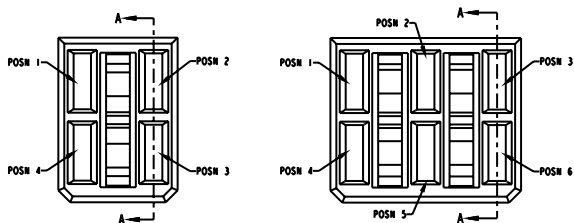

Note: For the receptacle modules, the first four digits following the dash in the part number specify the contact length in each contact position:  
 4 = long contact for first mate/last break  
 5 = short contact for last mate/first break  
 Reference the product drawing for additional information.

## HCI® HIGH POWER BACKPLANE/MIDPLANE CONNECTORS



Minimum Card Slot Spacing (mm)	Contacts		Current Rating		Number of Columns	Column Pitch (mm)	Module Width Along Card Edge (mm)	With Molded Center Guide	Power Module Part Numbers	
	Total	Per Column	Amps per Contact	Amps per Module					Backplane/Midplane	Daughter Card
									Vertical Receptacle	Right-Angle Header
25	2	1	83	166	2	14.6	22.9	yes	10087939-001LF	10087937-001LF
24	2	1	83	166	2	7.3	15.6	no	10078768-001LF	10078770-001LF
24	3	1	75	225	3	7.3	22.9	no	10078902-001LF	10078904-001LF

Note: For right-angle headers with one first mate/last break contact, please use the -002LF dash number option. Reference the product drawing for additional information.

Listed part numbers designate the standard lead-free offering. Contact FCI to request options with tin-lead finish in termination areas.

### BACKPLANE/MIDPLANE GUIDE MODULES Blade style with no keying or ESD options



Minimum Card Slot Spacing (mm)	Guide Module Width (mm)	Guide Pin Length (mm)	Guide Pin Thread Style	Guide Module Part Numbers	
				Backplane/Midplane	Daughter Card
				Guide Pin	Right-Angle Guide Module
20	7.2	18.3	External threads	10037915-101LF	10037909-101LF
20	7.2	25.3	External threads	10037908-101LF	10037909-101LF
20	7.2	25.3	Internal threads	10066832-101LF	10037909-101LF
17	7.2	25.3	External threads	10045368-101LF	10045367-101LF

### BACKPLANE/MIDPLANE GUIDE MODULES Pin style with keying and ESD options



Minimum Card Slot Spacing (mm)	Guide Module Width (mm)	Guide Pin Length (mm)	Guide Pin Thread Style	Guide Module Part Numbers	
				Backplane/Midplane	Daughter Card
				Guide Pin	Right-Angle Guide Module
20	10.8	32.0	External threads	10037910-1xxLF	10037912-1xyLF
20	10.8	32.0	Internal threads	10037911-1xxLF	10037912-1xyLF
17	10.8	32.0	External threads	10037910-1xxLF	10045597-1xyLF
17	10.8	32.0	Internal threads	10037911-1xxLF	10045597-1xyLF

Notes: For backplane guide pin modules, "xx" is dictated by the backplane thickness. Replace with code from product drawing. Reference the product drawing for additional information.

For right-angle guide modules, "x" = 1 without ESD clip; "x" = 0 with ESD clip. "y" designates the keying angle option. Reference the product drawing for additional information.

y	key angle
1	0°
2	45°
3	90°
4	135°
5	180°
6	215°
7	270°
8	315°
9	no key

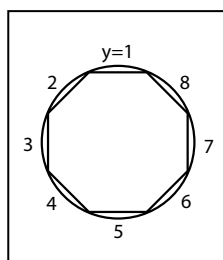

# AIRMAX VS<sup>®</sup> ORTHOGONAL MIDPLANE CONNECTORS

## FEATURES

- ▶ Enable orthogonal midplane system architecture
- ▶ Provide a direct connection between vertical line card cards and horizontal switch or communications cards on opposite sides of a midplane
- ▶ Provide capability to support 16 differential pair crossovers in a single module
- ▶ Headers install back-to-back and at 90° to each other
- ▶ Header signal pins share vias to provide a direct connection, eliminating the need for connecting traces
- ▶ Halogen-free connectors aid efforts to minimize the use of environmentally sensitive materials
- ▶ Use the same power and guide modules as backplane or midplane applications

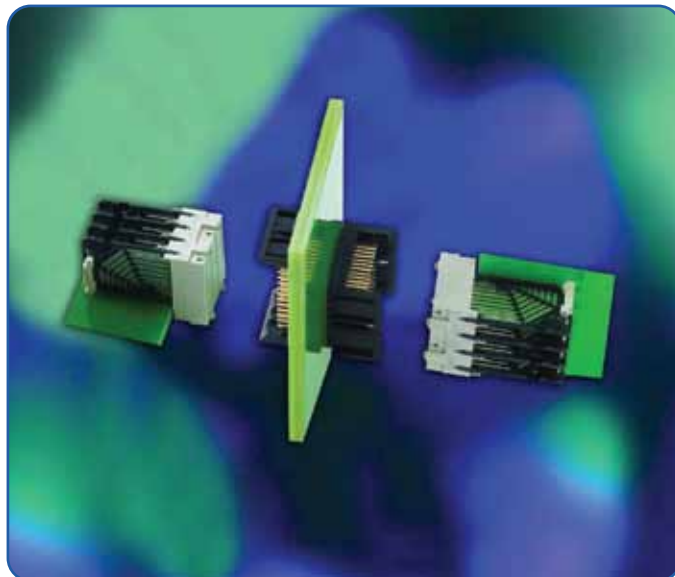

## TECHNICAL DATA

### MATERIALS

- ▶ Contacts: Copper alloy
- ▶ Contact finish
  - Performance-based plating over nickel at separable interface
  - Tin over nickel on press-fit tails on standard lead-free products. Tin-lead option available upon request.
- ▶ Housings: High-temperature thermoplastic, UL 94V-0

### MECHANICAL PERFORMANCE

- ▶ Durability: 200 cycles
- ▶ Mating force: 0.60N maximum/contact
- ▶ Unmating force: 0.15N minimum/contact
- ▶ Compliant pin insertion force: 40N maximum

### SPECIFICATIONS

- ▶ Product specification: GS-12-239
- ▶ Application specification: GS-20-035

### APPROVALS AND CERTIFICATIONS

- ▶ Telcordia GR-1217-CORE Central Office

### PACKAGING

- ▶ Tubes

### ELECTRICAL PERFORMANCE

- ▶ Contact resistance:  $\leq 35 \text{ m}\Omega$  initial,  $\leq 10 \text{ m}\Omega$  increase after environmental test
- ▶ Current rating ( $\leq 30^\circ\text{C}$  rise above ambient in still air): 0.5A/contact with all contacts powered
- ▶ Differential impedance:  $100 \pm 10\Omega$  @ 90 ps (10-90%) rise time
- ▶ Differential insertion loss:  $< 2\text{dB}$  through 6.25 Gb/s;  $< 3.5 \text{ dB}$  through 12.5 Gb/s

## PART NUMBERS

Differential Impedance (ohms)	Minimum Card Slot Spacing (mm)	Differential Pairs		Total Contacts	Number of Columns	Column Pitch (mm)	Header Type	Module Width Along Card Edge (mm)	Signal Module Part Numbers	
		Total	Per Column						Midplane	Daughter Card
									Vertical Header	Right-Angle Receptacle
100	23	16	4	48	4	4.2	2-wall	16.6	10073718-101LF	10074050-101LF

▶ Listed part numbers designate the standard lead-free offering. Contact FCI to request options with tin-lead finish in termination areas.

## ZIPLINE® ORTHOGONAL MIDPLANE CONNECTORS

### FEATURES

- Provide capability to support 36 or 72 differential pair crossovers in a single module
- Headers install back-to-back and at 90° to each other
- Header signal pins share vias to provide a direct connection, eliminating the need for connecting traces
- Use the same right-angle receptacle as backplane, midplane, or coplanar applications
- Flexible design allows columns to be allocated to backplane or power wafers for product customization
- Halogen-free connectors aid efforts to minimize the use of environmentally sensitive materials
- Use the same power and guide modules as backplane or midplane applications

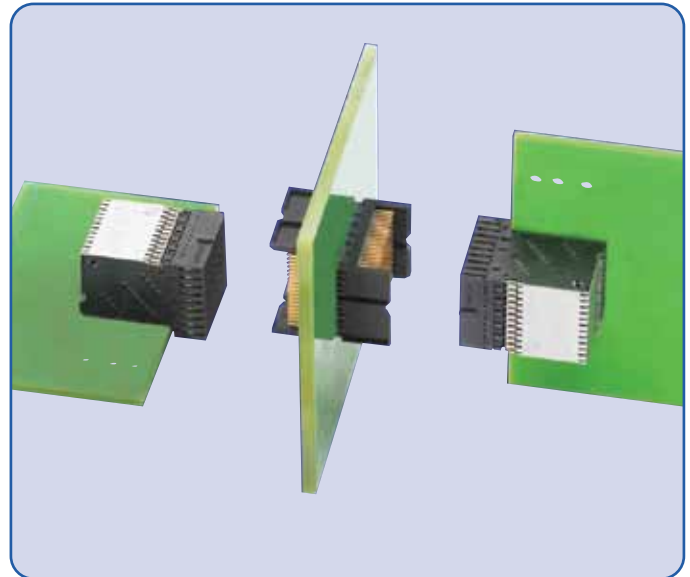

### TECHNICAL DATA

#### MATERIALS

- Contacts: Copper alloy
- Contact finish
  - Performance-based plating over nickel at separable interface
  - Tin over nickel on press-fit tails on standard lead-free products. Tin-lead option available upon request.
- Housings: High-temperature thermoplastic, UL 94V-0
- Organizer: Stainless steel

#### MECHANICAL PERFORMANCE

- Durability: 200 cycles
- Mating force: 0.40N maximum/contact
- Unmating force: 0.10N minimum/contact
- Compliant pin insertion force: 25N maximum

#### SPECIFICATIONS

- Product specification: GS-12-452
- Application specification: GS-20-094

#### APPROVALS AND CERTIFICATIONS

- Telcordia GR-1217-CORE Central Office

#### PACKAGING

- Tubes

#### ELECTRICAL PERFORMANCE

- Contact resistance:  $\leq 130 \text{ m}\Omega$  initial,  $\leq 10 \text{ m}\Omega$  increase after environmental test
- Current rating ( $\leq 30^\circ\text{C}$  rise above ambient in still air): 0.25A/contact with all contacts powered
- Differential impedance:  $100 \pm 12\Omega$  @ 60 ps (20-80%) rise time
- Differential insertion loss:  $< 2\text{dB}$  through 6.25 Gb/s;  $< 5 \text{ dB}$  through 12.5 Gb/s
- Near-end crosstalk (multi-active):  $< -35 \text{ dB}$  through 6.25 Gb/s;  $< -25 \text{ dB}$  through 12.5 Gb/s
- Far-end crosstalk (multi-active):  $< -36 \text{ dB}$  through 6.25 Gb/s;  $< -26 \text{ dB}$  through 12.5 Gb/s

### PART NUMBERS

Differential Impedance (ohms)	Minimum Card Slot Spacing (mm)	Differential Pairs		Total Contacts	Number of Columns	Column Pitch (mm)	Header Type	Module Width Along Card Edge (mm)	Signal Module Part Numbers		
		Total	Per Column						Midplane		Right-Angle Receptacle
									Vertical Header	Daughter Card	
100	29	96	6	288	16	1.8	2-wall	28.8	10084160-101LF	10084155-101LF	
100	27	72	6	216	12	1.8	2-wall	21.6	10076222-101LF	10076209-101LF	
100	27	72	6	216	12	1.8	4-wall	23.4	10080640-101LF	10076209-101LF	
100	27	36	6	108	6	3.6	2-wall	21.6	10078557-101LF	10078550-101LF	

Note: The Zipline module with 96 differential pairs provides 72 orthogonal pass/through pairs and 24 backplane pairs.

Listed part numbers designate the standard lead-free offering. Contact FCI to request options with tin-lead finish in termination areas.

## AIRMAX VS<sup>®</sup> COPLANAR CONNECTORS

### FEATURES

- Modules are ideally suited for coplanar card extender applications or for Zone 3 connections between a front board and rear transition module in ATCA<sup>®</sup> systems
- Uses the same right-angle receptacle and header signal modules as backplane or midplane applications
- Designs optimized for either 100Ω or 85Ω impedance to match channel impedance and reduce loss
- Halogen-free signal modules aid efforts to minimize the use of environmentally sensitive materials
- Available power and guide modules complement signal connector offering



### TECHNICAL DATA

#### MATERIALS

- Contacts: Copper alloy
- Contact finish
  - Performance-based plating over nickel at separable interface
  - Tin over nickel on press-fit tails on standard lead-free products. Tin-lead option available upon request.
- Housings: High-temperature thermoplastic, UL 94V-0

#### MECHANICAL PERFORMANCE

- Durability: 200 cycles
- Mating force: 0.45N maximum/contact
- Unmating force: 0.15N minimum/contact
- Compliant pin insertion force: 40N maximum

#### SPECIFICATIONS

- Product specification: GS-12-239
- Application specification: GS-20-035

#### APPROVALS AND CERTIFICATIONS

- Telcordia GR-1217-CORE Central Office

#### PACKAGING

- Tubes

#### ELECTRICAL PERFORMANCE

- Contact resistance:  $\leq 50 \text{ m}\Omega$  initial,  $\leq 10 \text{ m}\Omega$  increase after environmental test
- Current rating ( $\leq 30^\circ\text{C}$  rise above ambient in still air): 0.5A/contact with all contacts powered

#### 100Ω Connectors

- Differential impedance:  $100 \pm 6\Omega$  @ 80 ps (10-90%) rise time
- Differential insertion loss:  $< 1.5 \text{ dB}$  through 6.25 Gb/s;  $< 3.5 \text{ dB}$  through 12.5 Gb/s
- Near-end crosstalk (multi-active):  $< -33 \text{ dB}$  through 6.25 Gb/s;  $< -28 \text{ dB}$  through 12.5 Gb/s
- Far-end crosstalk (multi-active):  $< -31 \text{ dB}$  through 6.25 Gb/s;  $< -25 \text{ dB}$  through 12.5 Gb/s

#### 85Ω Connectors

- Differential impedance:  $85 \pm 5\Omega$  @ 50 ps (10-90%) risetime
- Differential insertion loss:  $< 1.5 \text{ dB}$  through 8 Gb/s
- Near-end crosstalk (multi-active):  $< -30 \text{ dB}$  through 8 Gb/s
- Far-end crosstalk (multi-active):  $< -30 \text{ dB}$  through 8 Gb/s

## ZIPLINE® COPLANAR CONNECTORS

### FEATURES

- ▶ Modules with 6 differential pairs/column provide maximum linear signal density along card edge: 84.6 differential pairs per inch
- ▶ Uses the same right-angle receptacle signal modules as backplane or midplane applications
- ▶ Stainless steel organizer allows use of flat-rock tooling for connector installation
- ▶ Halogen-free signal modules aid efforts to minimize the use of environmentally sensitive materials
- ▶ Available power and guide modules complement signal connector offering

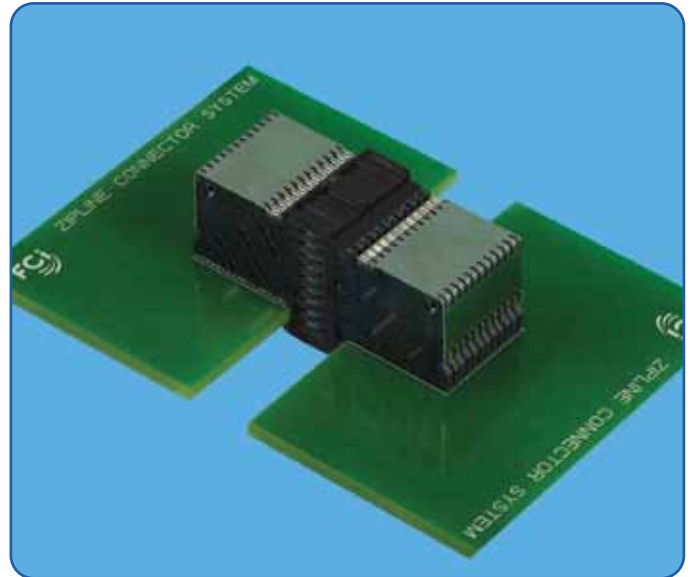

### TECHNICAL DATA

#### MATERIALS

- ▶ Contacts: Copper alloy
- ▶ Contact finish
  - Performance-based plating over nickel at separable interface
  - Tin over nickel on press-fit tails on standard lead-free products. Tin-lead option available upon request.
- ▶ Housings: High-temperature thermoplastic, UL 94V-0
- ▶ Organizer: Stainless steel

#### MECHANICAL PERFORMANCE

- ▶ Durability: 200 cycles
- ▶ Mating force: 0.40N maximum/contact
- ▶ Unmating force: 0.10N minimum/contact
- ▶ Compliant pin insertion force: 25N maximum

#### SPECIFICATIONS

- ▶ Product specification: GS-12-452
- ▶ Application specification: GS-20-094

#### APPROVALS AND CERTIFICATIONS

- ▶ Telcordia GR-1217-CORE Central Office

#### PACKAGING

- ▶ Tubes

#### ELECTRICAL PERFORMANCE

- ▶ Contact resistance:  $\leq 130 \text{ m}\Omega$  initial,  $\leq 10 \text{ m}\Omega$  increase after environmental test
- ▶ Current rating ( $\leq 30^\circ\text{C}$  rise above ambient in still air): 0.25A/contact with all contacts powered
- ▶ Differential impedance:  $100 \pm 11 \Omega$  @ 50 ps (20-80%) rise time
- ▶ Differential insertion loss:  $< 0.9\text{dB}$  through 6.25 Gb/s;  $< 1.5 \text{ dB}$  through 12.5 Gb/s
- ▶ Near-end crosstalk (multi-active):  $< -24 \text{ dB}$  through 6.25 Gb/s;  $< -22 \text{ dB}$  through 12.5 Gb/s
- ▶ Far-end crosstalk (multi-active):  $< -24 \text{ dB}$  through 6.25 Gb/s;  $< -23 \text{ dB}$  through 12.5 Gb/s

## AIRMAX VS® & ZIPLINE® COPLANAR SIGNAL MODULES

### TYPICAL APPLICATIONS & SIGNAL DENSITY

Minimum Card Slot Spacing (mm)	column pitch (mm)	Differential Pairs			Contacts			Product Family
		per column	Linear Density		per column	Linear Density		
			per inch	per cm		per inch	per cm	
27	1.8	6	84.6	33.3	18	254.0	100	ZipLine
25	2.0	5	63.5	25.0	15	190.5	75	AirMax VS
25	3.0	5	42.3	16.7	15	127.0	50	AirMax VS
20	2.0	4	50.8	20.0	12	152.4	60	AirMax VS
20	3.0	4	33.9	13.3	12	101.6	40	AirMax VS
17	2.0	3	38.1	15.0	9	114.3	45	AirMax VS

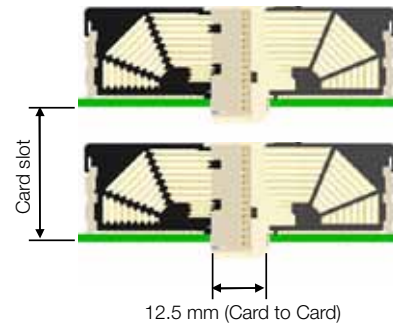

### AIRMAX VS® SIGNAL MODULES

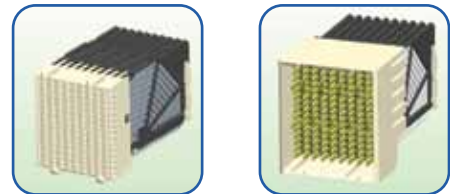

Differential Impedance (ohms)	Minimum Card Slot Spacing (mm)	Differential Pairs		Total Contacts	Number of Columns	Column Pitch (mm)	Header Type	Module Width Along Card Edge (mm)	Signal Module Part Numbers	
		Total	Per Column						Right-Angle Receptacle	Right-Angle Header
85	25	50	5	150	10	2.0	4-wall	22.0	10095504-101LF	10097311-101LF
85	25	50	5	150	10	3.0	4-wall	32.0	10095505-101LF	10087771-101LF
100	25	50	5	150	10	2.0	2-wall	20.0	10034475-101LF	10016527-101LF
100	25	50	5	150	10	2.0	4-wall	22.0	10034475-101LF	10025613-101LF
100	25	50	5	150	10	3.0	2-wall	30.0	10057041-101LF	10037323-101LF
100	25	50	5	150	10	3.0	4-wall	32.0	10057041-101LF	10037324-101LF
100	25	40	5	120	8	2.0	2-wall	16.0	10045548-101LF	10041746-101LF
100	25	40	5	120	8	2.0	4-wall	18.0	10045548-101LF	10041460-101LF
100	20	40	4	120	10	2.0	2-wall	20.0	10035754-101LF	10029391-101LF
100	20	40	4	120	10	2.0	4-wall	22.0	10035754-101LF	10028436-101LF
100	20	40	4	120	10	3.0	2-wall	30.0	10045722-101LF	10035514-101LF
100	20	40	4	120	10	3.0	4-wall	32.0	10045722-101LF	10035515-101LF
100	20	32	4	96	8	2.0	2-wall	16.0	10060905-101LF	10052837-101LF
100	20	32	4	96	8	2.0	4-wall	18.0	10060905-101LF	10052838-101LF
100	17	30	3	90	10	2.0	2-wall	20.0	10056335-101LF	10034264-101LF
100	17	30	3	90	10	2.0	4-wall	22.0	10056335-101LF	10034249-101LF
100	17	24	3	72	8	2.0	2-wall	16.0	10077323-101LF	10045266-101LF
100	17	24	3	72	8	2.0	4-wall	18.0	10077323-101LF	10045267-101LF
100	17	18	3	54	6	2.0	2-wall	12.0	10053656-101LF	10040862-101LF
100	17	18	3	54	6	2.0	4-wall	14.0	10053656-101LF	10039851-101LF

### ZIPLINE® SIGNAL MODULES

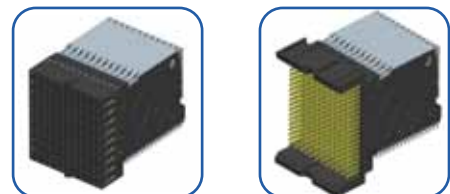

Differential Impedance (ohms)	Minimum Card Slot Spacing (mm)	Differential Pairs		Total Contacts	Number of Columns	Column Pitch (mm)	Header Type	Module Width Along Card Edge (mm)	Signal Module Part Numbers	
		Total	Per Column						Right-Angle Receptacle	Right-Angle Header
100	27	72	6	216	12	1.8	2-wall	21.6	10076209-101LF	10077555-101LF

■ Listed part numbers designate the standard lead-free offering. Contact FCI to request options with tin-lead finish in termination areas.



## HARD METRIC COPLANAR POWER CONNECTORS

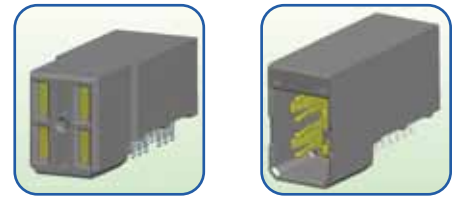

Minimum Card Slot Spacing (mm)	Contacts		Current Rating		Number of Columns	Column Pitch (mm)	Module Width Along Card Edge (mm)	Power Module Part Numbers	
	Total	Per Column	Amps per Contact	Amps per Module				Right-Angle Receptacle	Right-Angle Header
20	2	1	40	80	2	6.00	12.0	10052620-4444P00LF	10028918-001LF
20	2	1	40	80	2	6.00	12.0	10052620-4554P00LF	10028918-001LF
20	2	1	40	80	2	6.00	12.0	10052620-4555P00LF	10028918-001LF
20	4	2	20	80	2	6.00	12.0	10052620-4444P00LF	10028917-001LF
20	4	2	20	80	2	6.00	12.0	10052620-4554P00LF	10028917-001LF
20	4	2	20	80	2	6.00	12.0	10052620-4555P00LF	10028917-001LF
20	4	2	20	80	2	6.00	12.0	10052620-5455P00LF	10028917-001LF
17	4	2	20	80	2	6.00	12.0	10052620-4444P00LF	10073379-001LF
17	4	2	20	80	2	6.00	12.0	10052620-4554P00LF	10073379-001LF
17	4	2	20	80	2	6.00	12.0	10052620-4555P00LF	10073379-001LF
17	4	2	20	80	2	6.00	12.0	10052620-5455P00LF	10073379-001LF

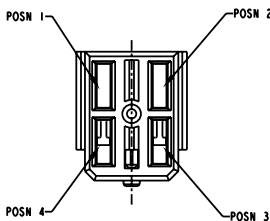

- Note: For the receptacle modules, the first four digits following the dash in the part number specify the contact length in each contact position:  
 4 = long contact for first mate/last break  
 5 = short contact for last mate/first break  
 Reference the product drawing for additional information.
- Listed part numbers designate the standard lead-free offering.  
 Contact FCI to request options with tin-lead finish in termination areas.

## COPLANAR GUIDE MODULES

### Pin style Coplanar Guide Modules with keying and ESD options

Minimum Card Slot Spacing (mm)	Module Width Along Card Edge (mm)	Guide Pin Length (mm)	Guide Module Part Numbers	
			Right-Angle Guide Pin	Right-Angle Guide Module
20	10.8	29.9	10044366-10yLF	10037912-1xyLF
17	10.8	29.9	10045509-10yLF	10045597-1xyLF

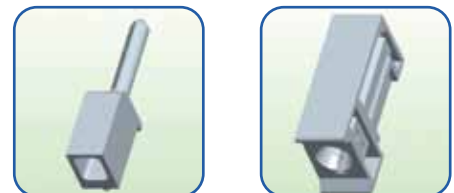

### Blade style Coplanar Guide Modules with no keying or ESD options

Minimum Card Slot Spacing (mm)	Module Width Along Card Edge (mm)	Guide Blade Length (mm)	Guide Module Part Numbers	
			Right-Angle Guide Blade	Right-Angle Guide Module
20	7.2	25.3	10044314-101LF	10037909-101LF
17	7.2	25.3	10045588-101LF	10045367-101LF

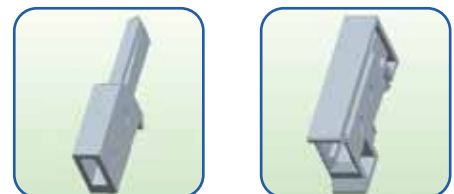

y	key angle
1	0°
2	45°
3	90°
4	135°
5	180°
6	215°
7	270°
8	315°

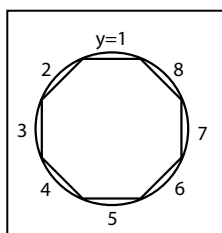

- Notes: For right-angle guide pin modules, “y” is designates the keying angle option.. Reference the product drawing for additional information.
- For right-angle guide modules, “x” = 1 without ESD clip; “x” = 0 with ESD clip. “y” designates the keying angle option. Reference the product drawing for additional information.

# AIRMAX VS® MEZZANINE CONNECTORS

## FEATURES

- Modules provide support for mezzanine applications such as memory, storage or high-speed I/O expansion in servers, storage or networking equipment
- Uses the same vertical receptacle and header modules as backplane or midplane applications to accomplish 12.5mm stack height
- Taller vertical headers enable 26mm stack height
- Halogen-free connectors aid efforts to minimize the use of environmentally sensitive materials
- The press block for header installation also serves as a protective cover

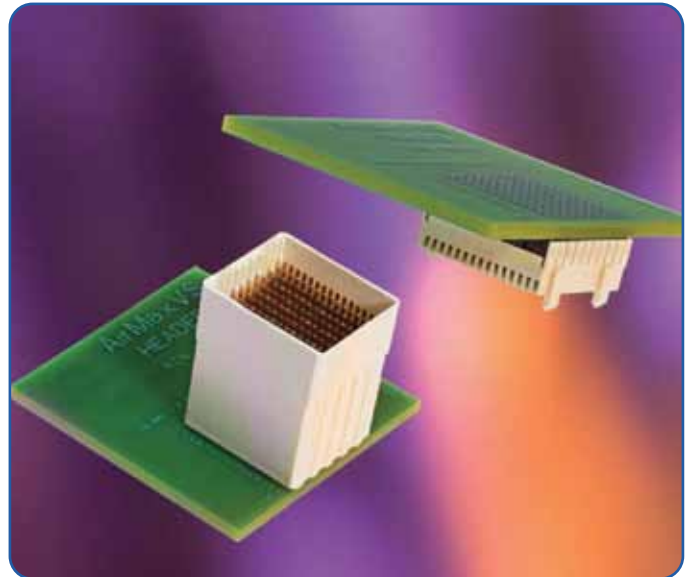

## TECHNICAL DATA

### MATERIALS

- Contacts: Copper alloy
- Contact finish
  - Performance-based plating over nickel at separable interface
  - Tin over nickel on press-fit tails on standard lead-free products. Tin-lead option available upon request.
- Housings: High-temperature thermoplastic, UL 94V-0

### MECHANICAL PERFORMANCE

- Durability: 200 cycles
- Mating force: 0.45N maximum/contact
- Unmating force: 0.15N minimum/contact
- Compliant pin insertion force: 40N maximum

### SPECIFICATIONS

- Product specification: GS-12-379
- Application specification: GS-20-069

### ELECTRICAL PERFORMANCE

- Contact resistance:  $\leq 50 \text{ m}\Omega$  initial,  $\leq 10 \text{ m}\Omega$  increase after environmental test
- Current rating ( $\leq 30^\circ\text{C}$  rise above ambient in still air): 0.5A/contact with all contacts powered
- Differential impedance:  $100 \pm 5\Omega$  @ 100 ps (10-90%) rise time
- Differential insertion loss:  $< 0,5\text{dB}$  through 6.25 Gb/s;  $< 1 \text{ dB}$  through 12.5 Gb/s
- Near-end crosstalk (multi-active):  $< -39 \text{ dB}$  through 6.25 Gb/s;  $< -34 \text{ dB}$  through 12.5 Gb/s
- Far-end crosstalk (multi-active):  $< -42 \text{ dB}$  through 6.25 Gb/s;  $< -34 \text{ dB}$  through 12.5 Gb/s

### APPROVALS AND CERTIFICATIONS

- Telcordia GR-1217-CORE Central Office

### PACKAGING

- Tubes
- Trays (vertical receptacle only)

## PART NUMBERS

Differential Impedance (ohms)	Stack Height (mm)	Differential Pairs		Total Contacts	Number of Columns	Column Pitch (mm)	Header Type	Module Length (mm)	Signal Module Part Numbers	
		Total	Per Column						Vertical Receptacle	Vertical Header
100	12.5	50	5	150	10	2.0	2-wall	20.0	10016537-101LF	10056098-1050011LF
100	12.5	50	5	150	10	3.0	2-wall	30.0	10035146-101LF	10056427-1050011LF
100	12.5	40	5	120	8	2.0	2-wall	16.0	10040993-101LF	10055140-1050011LF
100	12.5	40	4	120	10	2.0	2-wall	20.0	10028264-101LF	10056100-1050011LF
100	12.5	40	4	120	10	2.0	4-wall	22.0	10028264-101LF	10056100-1080011LF
100	12.5	40	4	120	10	3.0	2-wall	30.0	10035465-101LF	10056430-1050011LF
100	12.5	40	4	120	10	3.0	4-wall	32.0	10035465-101LF	10056430-1080011LF
100	12.5	32	4	96	8	2.0	2-wall	16.0	10052842-101LF	10055307-1050011LF
100	12.5	30	3	90	10	2.0	2-wall	20.0	10034251-101LF	10056103-1050011LF
100	12.5	30	3	90	10	2.0	4-wall	22.0	10034251-101LF	10056103-1080011LF
100	12.5	18	3	54	6	2.0	2-wall	12.0	10043546-101LF	10056101-1050011LF
100	26	50	5	150	10	2.0	4-wall	22.0	10016537-101LF	10056246-10711LF
100	26	50	5	150	10	3.0	4-wall	32.0	10035146-101LF	10059957-10711LF

■ Listed part numbers designate the standard lead-free offering. Contact FCI to request options with tin-lead finish in termination areas.

## AIRMAX VS<sup>®</sup> SIGNAL I/O CONNECTORS

### FEATURES

- ▶ The signal headers are designed to accept AirMax VS high-speed cable assemblies from W.L. Gore or FCI
- ▶ Vertical connectors allow for cabling to a backplane
- ▶ Right-angle configurations facilitate I/O connections to front or rear-mounted daughter cards
- ▶ Modules provide 4 differential signal pairs per column
- ▶ Header walls include features to accommodate passive latching on cable assembly ends
- ▶ Customized solutions can be designed to address specific internal or external application requirements, including alternative cable retention, such as active latches or jack screws, and/or EMI shielding
- ▶ Side-stackable headers and cable wafers provide flexibility to configure solutions to system design needs

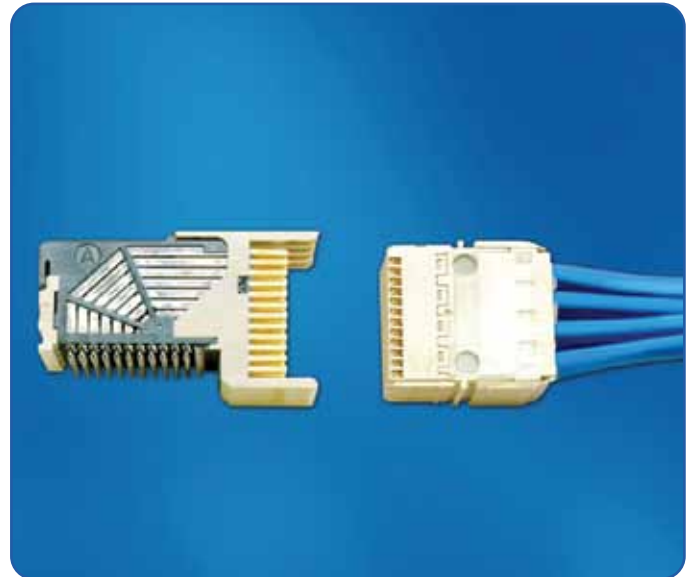

### TECHNICAL DATA

#### MATERIALS

- ▶ Contacts: Copper alloy
- ▶ Contact finish
  - Performance-based plating over nickel at separable interface
  - Tin over nickel on press-fit tails on standard lead-free products. Tin-lead option available upon request.
- ▶ Housings: High-temperature thermoplastic, UL 94V-0

#### MECHANICAL PERFORMANCE

- ▶ Durability: 200 cycles
- ▶ Mating force: 0.60N maximum/contact
- ▶ Unmating force: 0.15N minimum/contact
- ▶ Compliant pin insertion force: 40N maximum
- ▶ Cable retention: Dependent upon retention mechanism on cable end

#### SPECIFICATIONS

- ▶ Product specification: GS-12-344
- ▶ Application specification: GS-20-035

#### ELECTRICAL PERFORMANCE

- ▶ Contact resistance:  $\leq 50 \text{ m}\Omega$  initial,  $\leq 10 \text{ m}\Omega$  increase after environmental test
- ▶ Current rating ( $\leq 30^\circ\text{C}$  rise above ambient in still air): 0.5A/contact with all contacts powered
- ▶ Differential impedance:  $100 \pm 8\Omega$  @ 50 ps (10-90%) rise time
- ▶ Differential insertion loss: Link performance is dependent upon cable assembly length

#### APPROVALS AND CERTIFICATIONS

- ▶ Telcordia GR-1217-CORE Central Office

#### PACKAGING

- ▶ Tubes

### PART NUMBERS

Differential Impedance (ohms)	Minimum Card Slot Spacing (mm)	Differential Pairs		Total Contacts	Number of Columns	Column Pitch (mm)	Header Type	Module Width Along Card Edge (mm)	Signal Module Part Numbers
		Total	Per Column						
100	21	40	4	120	10	2.0	2-wall, right-angle	20.0	10041398-101LF
100	21	32	4	96	8	2.0	2-wall, right-angle	16.0	10061399-101LF
100	21	24	4	72	6	3.0	2-wall, right-angle	18.0	10062319-101LF
100	21	40	4	120	10	2.0	2-wall, vertical	20.0	10041268-1010031LF

▶ For additional information about corresponding AirMax VS cable assemblies, contact FCI at [airmax@fci.com](mailto:airmax@fci.com)

▶ Listed part numbers designate the standard lead-free offering. Contact FCI to request options with tin-lead finish in termination areas.

# GUIDE MODULES

## COMPLEMENT AIRMAX VS® & ZIPLINE® CONNECTOR FAMILIES

### FEATURES

- ▶ Guidance modules assure proper connector alignment prior to connector engagement
- ▶ Suitable for backplane, coplanar or orthogonal midplane applications in Hard Metric environments
- ▶ Modules fitting 20mm slot pitch complement AirMax 4-pair or 5-pair modules or ZipLine 6-pair signal modules
- ▶ Modules fitting 17mm slot pitch complement AirMax 3-pair signal modules or can be used with taller signal modules to provide more clearance for airflow
- ▶ Guide pin modules offer coding and ESD options
- ▶ Narrower blade-style modules require less board space
- ▶ Rugged die-cast construction

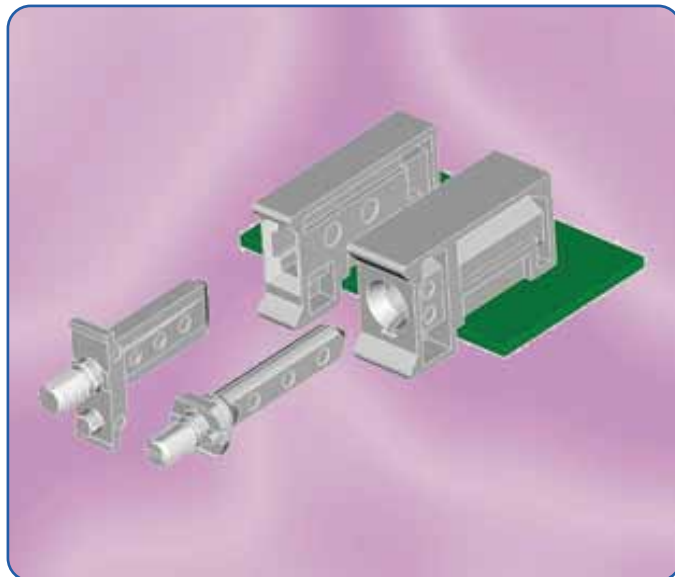

### TECHNICAL DATA

#### MATERIALS

- ▶ Base metal: Zinc alloy
- ▶ Finish:
  - Body: Zinc yellow chromate
  - ESD contact: Nickel

#### SPECIFICATIONS

- ▶ Application specification: GS-20-045

#### APPROVALS AND CERTIFICATIONS

- ▶ Lead-free and RoHS compliant

#### PACKAGING

- ▶ Trays (guide pins)
- ▶ Tubes (guide modules)

#### MECHANICAL PERFORMANCE

- ▶ Misalignment correction:
  - Pin-style modules: +/- 3.5mm max. in direction perpendicular or parallel to daughter card
  - Blade-style modules: +/- 2.9mm max. in direction perpendicular or parallel to card
- ▶ Clearance after full guidance:
  - Pin-style modules: 0.35mm nominal (0.175mm surrounding the pin) between pin and receptacle
  - Blade-style modules: 0.25mm nominal (0.125mm per side) in the direction perpendicular to the daughter card and 0.30mm nominal (0.15mm per side) in the direction parallel to the daughter card

### GUIDE TO KEYING AND ESD OPTIONS FOR PIN-STYLE MODULES

- ▶ This information is applicable to the right-angle, pin-style modules that appear on the facing page.

- ▶ For right-angle guide modules,
  - “x” = 1 without ESD clip;
  - “x” = 0 with ESD clip.
  - “y” designates the keying angle option.
 For example, 10037912-113LF designates a guide module with an ESD clip and with the flat wall for keying in the 90° position.

- ▶ For right-angle guide pin modules, “y” designates the keying angle option. Note that keying option 9 is not available for right-angle guide pin modules. For example, 10044366-102LF designates a guide pin with the flat wall for keying in the 45° position.

- ▶ Reference the product drawings for additional information.

y	key angle
1	0°
2	45°
3	90°
4	135°
5	180°
6	215°
7	270°
8	315°
9	no key

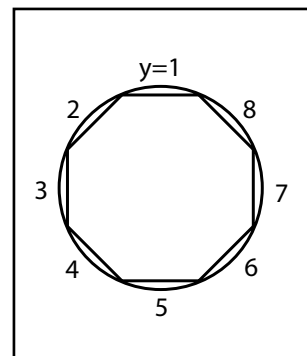

## PIN STYLE GUIDE MODULES with keying and ESD options

### BACKPLANE / MIDPLANE APPLICATIONS

Minimum Card Slot Spacing (mm)	Guide Module Width (mm)	Guide Pin Length (mm)	Guide Pin Thread Style	Guide Module Part Numbers	
				Backplane/Midplane	Daughter Card
				Guide Pin	Right-Angle Guide Module
20	10.8	32.0	External threads	10037910-1xxLF	10037912-1xyLF
20	10.8	32.0	Internal threads	10037911-1xxLF	10037912-1xyLF
17	10.8	32.0	External threads	10037910-1xxLF	10045597-1xyLF
17	10.8	32.0	Internal threads	10037911-1xxLF	10045597-1xyLF



■ Note: For backplane guide pin modules, "xx" is dictated by the backplane thickness. Replace with code from product drawing. Reference the product drawing for additional information.

### COPLANAR APPLICATIONS

Minimum Card Slot Spacing (mm)	Module Width Along Card Edge (mm)	Guide Pin Length (mm)	Guide Module Part Numbers	
			Right-Angle Guide Pin	Right-Angle Guide Module
20	10.8	29.9	10044366-10yLF	10037912-1xyLF
17	10.8	29.9	10045509-10yLF	10045597-1xyLF



■ Modules fitting 20mm card slot pitch complement AirMax VS signal modules having 4 or 5 differential pairs/column or ZipLine signal modules with 6 pairs/ column. Modules fitting 17mm slot pitch also complement AirMax VS 3-pair modules.

## BLADE STYLE GUIDE MODULES with no keying or ESD options

### BACKPLANE / MIDPLANE APPLICATIONS

Minimum Card Slot Spacing (mm)	Guide Module Width (mm)	Guide Pin Length (mm)	Guide Pin Thread Style	Guide Module Part Numbers	
				Backplane/Midplane	Daughter Card
				Guide Pin	Right-Angle Guide Module
20	7.2	18.3	External threads	10037915-101LF	10037909-101LF
20	7.2	25.3	External threads	10037908-101LF	10037909-101LF
20	7.2	25.3	Internal threads	10066832-101LF	10037909-101LF
17	7.2	25.3	External threads	10045368-101LF	10045367-101LF



### COPLANAR APPLICATIONS

Minimum Card Slot Spacing (mm)	Module Width Along Card Edge (mm)	Guide Blade Length (mm)	Guide Module Part Numbers	
			Right-Angle Guide Blade	Right-Angle Guide Module
20	7.2	25.3	10044314-101LF	10037909-101LF
17	7.2	25.3	10045588-101LF	10045367-101LF



■ Modules fitting 20mm card slot pitch complement AirMax VS signal modules having 4 or 5 differential pairs/column or ZipLine signal modules with 6 pairs/ column. Modules fitting 17mm slot pitch also complement AirMax VS 3-pair modules.

# HARD METRIC HIGH POWER CONNECTORS

## FEATURES

- Current rating to 40A/contact in 1x2 modules without exceeding a 30°C temperature rise in still air
- Current rating to 20A/contact in 2x2 and 2x3 modules without exceeding a 30°C temperature rise in still air
- Compatible with Hard Metric (HM) Equipment Practice
- 1x2, 2x2 or 2x3 modules for backplane applications
- Options for first-mate/last-break sequencing
- Protected backplane connector UL 60950 Compliant (Finger Probe)
- 1x2 or 2x2 modules for coplanar applications
- Press-fit termination
- Compatible with lead-free processing temperatures



## TECHNICAL DATA

### MATERIALS

- Housing: High-temperature thermoplastic (UL 94V-0)
- Contact base metal: Copper alloy
- Contact Finish
  - Separable interface: Performance-based plating over nickel
  - Termination area: Tin or tin-lead over nickel

### MECHANICAL PERFORMANCE

- Durability: 200 cycles

### SPECIFICATIONS

- Product specification: GS-12-220
- Application specification: GS-20-023

### ELECTRICAL PERFORMANCE

- Current Rating: See table for maximum amps per contact for test configurations with dual (double sided) external copper pads of noted weight
- Operating voltage: 150V maximum
- Dielectric withstanding voltage: 1500V
- Insulation resistance: >10,000 MΩ minimum
- Contact Resistance: ≤1.0 mΩ initially and after environmental exposure

### APPROVALS AND CERTIFICATIONS

- UL 60950 & IEC 60950-1 Prevention of Operator Access to Energized Parts
- Telcordia GR-1217-CORE Central Office

### PACKAGING

- Tubes

Receptacle Type	Number of Connectors Fully Powered	Copper Pad Weight	Maximum Current Per Contact	
			1 x 2	2 x 2
Vertical Receptacle (2x2)	1	5oz	40A	20A
	Up to 5 adjacent	5oz	32A	14A
	1	2oz	32A	15A
	Up to 5 adjacent	2oz	27A	12A
R/A Receptacle (2x2)	1	2oz	37A	18A
	Up to 5 adjacent	2oz	29A	14A

**PART NUMBERS**

**HARD METRIC BACKPLANE/MIDPLANE POWER CONNECTORS**

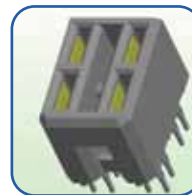

Minimum Card Slot Spacing (mm)	Contacts		Current Rating		Number of Columns	Column Pitch (mm)	Module Width Along Card Edge (mm)	Power Module Part Numbers	
	Total	Per Column	Amps per Contact	Amps per Module				Backplane/Midplane	Daughter Card
20	2	1	40	80	2	6.0	12.0	10028916-4444P00LF	10028918-001LF
20	2	1	40	80	2	6.0	12.0	10028916-4554P00LF	10028918-001LF
20	2	1	40	80	2	6.0	12.0	10028916-5555P00LF	10028918-001LF
20	4	2	20	80	2	6.0	12.0	10028916-4444P00LF	10028917-001LF
20	4	2	20	80	2	6.0	12.0	10028916-4455P00LF	10028917-001LF
20	4	2	20	80	2	6.0	12.0	10028916-4554P00LF	10028917-001LF
20	4	2	20	80	2	6.0	12.0	10028916-4555P00LF	10028917-001LF
20	4	2	20	80	2	6.0	12.0	10028916-5555P00LF	10028917-001LF
17	4	2	20	80	2	6.0	12.0	10028916-4444P00LF	10073379-001LF
17	4	2	20	80	2	6.0	12.0	10028916-4455P00LF	10073379-001LF
17	4	2	20	80	2	6.0	12.0	10028916-4554P00LF	10073379-001LF
17	4	2	20	80	2	6.0	12.0	10028916-4555P00LF	10073379-001LF
17	4	2	20	80	2	6.0	12.0	10028916-5554P00LF	10073379-001LF
17	4	2	20	80	2	6.0	12.0	10028916-5555P00LF	10073379-001LF
17	6	2	20	120	3	6.0	18.0	10061290-554555PLF	10061289-001LF
17	6	2	20	120	3	6.0	18.0	10061290-555444PLF	10061289-001LF
17	6	2	20	120	3	6.0	18.0	10061290-545555PLF	10061289-001LF

**PART NUMBERS**

**HARD METRIC COPLANAR POWER CONNECTORS**



Minimum Card Slot Spacing (mm)	Contacts		Current Rating		Number of Columns	Column Pitch (mm)	Module Width Along Card Edge (mm)	Power Module Part Numbers	
	Total	Per Column	Amps per Contact	Amps per Module				Right-Angle Receptacle	Right-Angle Header
20	2	1	40	80	2	6.00	12.0	10052620-4444P00LF	10028918-001LF
20	2	1	40	80	2	6.00	12.0	10052620-4554P00LF	10028918-001LF
20	2	1	40	80	2	6.00	12.0	10052620-4555P00LF	10028918-001LF
20	4	2	20	80	2	6.00	12.0	10052620-4444P00LF	10028917-001LF
20	4	2	20	80	2	6.00	12.0	10052620-4554P00LF	10028917-001LF
20	4	2	20	80	2	6.00	12.0	10052620-4555P00LF	10028917-001LF
20	4	2	20	80	2	6.00	12.0	10052620-5455P00LF	10028917-001LF
17	4	2	20	80	2	6.00	12.0	10052620-4444P00LF	10073379-001LF
17	4	2	20	80	2	6.00	12.0	10052620-4554P00LF	10073379-001LF
17	4	2	20	80	2	6.00	12.0	10052620-4555P00LF	10073379-001LF
17	4	2	20	80	2	6.00	12.0	10052620-5455P00LF	10073379-001LF

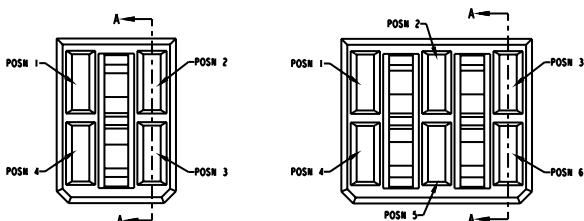

Note: For the receptacle modules, the first four digits following the dash in the part number specify the contact length in each contact position:  
 4 = long contact for first mate/last break  
 5 = short contact for last mate/first break  
 Reference the product drawing for additional information.

Listed part numbers designate the standard lead-free offering. Contact FCI to request options with tin-lead finish in termination areas.

# HCI® HIGH POWER BACKPLANE / MIDPLANE CONNECTORS

## FEATURES

- Current rating to 83A / contact for a 2 position module or 75A / contact for a 3 position module at a 30°C temperature rise in still air
- Compatible with Hard Metric (HM) Equipment Practice
- Supports backplane or midplane applications
- The two-position module with integrated center guide can eliminate the need for separate guidance
- Housing walls surround the power contacts to ensure that adjacent contacts cannot short together
- Options for first-mate/last-break sequencing
- Protected backplane/midplane receptacle is UL 60950 compliant (Test Finger & Test Probe)
- Press-fit termination is available for thicker boards
- Compatible with lead-free processing temperatures



## TECHNICAL DATA

### MATERIALS

- Housing: High-temperature thermoplastic (UL 94V-0), black
- Contact base metal: High-conductivity copper alloy
- Contact finish:
  - Separable interface: 30µin (0.76µm) performance-based plating over nickel (per the GS-12-380 product specification)
  - Termination area: Matte tin over nickel

### MECHANICAL PERFORMANCE

- Durability: 200 cycles

### SPECIFICATIONS

- Product specification: GS-12-380
- Application specification: GS-20-070

### ELECTRICAL PERFORMANCE

- Current rating: (≤ 30°C T-rise above ambient in still air)
  - 83A / contact maximum for a 2 position module
  - 75A / contact maximum for a 3 position module
- Operating voltage: 300V
- Dielectric withstanding voltage: 2500V
- Insulation resistance: >10,000 MΩ minimum
- Contact resistance: ≤ 0.5 mΩ initially and after environmental exposure

### APPROVALS AND CERTIFICATIONS

- UL – 95A per contact in still air
- CSA
- TUV
- UL 60950 compliant (Test Finger & Test Probe)
- Telcordia GR-1217-CORE, Central Office

### PACKAGING

- Tubes

## PART NUMBERS

Minimum Card Slot Spacing (mm)	Contacts		Current Rating		Number of Columns	Column Pitch (mm)	Module Width Along Card Edge (mm)	With Molded Center Guide	Power Module Part Numbers	
	Total	Per Column	Amps per Contact	Amps per Module					Backplane/Midplane	Daughter Card
									Vertical Receptacle	Right-Angle Header
25	2	1	83	166	2	14.6	22.9	yes	10087939-001LF	10087937-001LF
24	2	1	83	166	2	7.3	15.6	no	10078768-001LF	10078770-001LF
24	3	1	75	225	3	7.3	22.9	no	10078902-001LF	10078904-001LF

■ Note: For right angle headers with one first mate/last break contact, please use the -002LF dash number option.

- Listed part numbers designate the standard lead-free offering. Contact FCI to request options with tin-lead finish in termination areas.
- Product drawings, 3D models, specifications and additional technical information are available at [www.fciconnect.com/hcihighpower](http://www.fciconnect.com/hcihighpower)



# APPENDICES



## Appendices

- Industry Specifications
  - Storage Bridge Bay (SSB)
  - Intel® Quick Path Interconnect (Intel® QPI)
  - Server System Infrastructure (SSI) Blade Server
- Routing Examples
- Application Tooling
- Additional Resources

## AIRMAX VS® HIGH-SPEED CONNECTORS FOR STORAGE BRIDGE BAY MIDPLANE INTERFACE

### DESCRIPTION

The Storage Bridge Bay (SBB) Specification, targeted at low and midrange storage, provides requirements, guidelines and reference information to ensure compatibility between a storage enclosure controller slot and storage controllers from a variety of independent vendors. The specification defines the mechanical and electrical interfaces between a storage controller and the midplane within a storage enclosure. Any bridge/controller card supplied in accordance with this specification will be compatible and accommodated within any storage enclosure slot designed in conformance to the SBB specification. Examples include JBOD interface bridges and RAID, iSCSI SAN, Fibre Channel SAN or NAS controllers.

AirMax VS® high-speed signal connectors, guide modules, and power connectors meet the dimensional and electrical requirements for the Storage Bridge Bay Midplane Interface (SBBMI) to connect bridge/controller cards to the midplane in a drive enclosure.

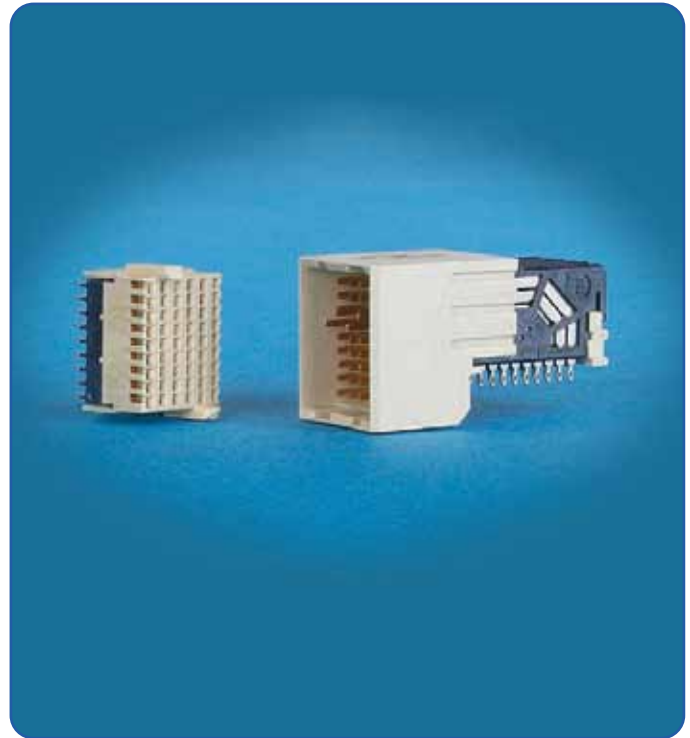

### FEATURES

- Innovative shield-less design and air dielectric between adjacent conductors deliver lowest insertion loss and crosstalk
- High-speed serial data rates can scale from 2.5 Gb/s to 12.5 Gb/s without requiring redesign of a basic platform
- Opposed dual-beam receptacle contact structure provides high reliability
- Contains no interleaving shields reducing connector weight, cost, and PCB routing complexity
- Compact 2x2 power connectors provide capacity for up to 20A/contact
- Rugged guide modules offer ESD grounding option
- Keyed guide modules differentiate between 2 Gb/s and 4 Gb/s Fibre Channel and 3 Gb/s SAS signal profiles
- Low-profile designs helps facilitate airflow through canister for cooling
- Compatible with Hard Metric design practice

### TARGET MARKETS / APPLICATIONS

- **Data Storage**
  - Low and midrange storage systems conforming to the Storage Bridge Bay (SBB) Specification, Version 1.0 or 2.0
    - Storage enclosures with up to 48 drives
    - 2 Gb/s and 4 Gb/s Fibre Channel or 3 Gb/s SAS signal profiles
  - Controllers conforming to the SBB Specification, Version 1.0 or 2.0
    - JBOD, RAID, iSCSI SAN, FC SAN, NAS, IB, VTL
    - Canister power profiles up to 200W

# AIRMAX VS® HIGH-SPEED CONNECTORS FOR STORAGE BRIDGE BAY MIDPLANE INTERFACE

## TECHNICAL INFORMATION

### PRODUCT SPECIFICATIONS

- GS-12-239 Press-fit signal connectors
- GS-12-220 Press-fit, high-power connectors

### APPLICATION SPECIFICATIONS

- GS-20-035 Press-fit signal connectors
- GS-20-023 Press-fit, high-power connectors
- GS-20-045 Hard-metric guide connectors

### INDUSTRY SPECIFICATIONS

- Storage Bridge Bay Specification (reference [www.sbbwg.org](http://www.sbbwg.org))
- Telcordia GR-1217-CORE, Central Office

### ADDITIONAL INFORMATION

- AirMax VS High-Speed Connector System: Signal Integrity Test Procedures and Performance
- Use web link [www.fci.com/airmax](http://www.fci.com/airmax) to obtain specifications, product drawings and additional technical information.

## APPLICATION EXAMPLE

- A Storage Bridge Bay Midplane Interface (SBBMI) in accordance with the Version 2.0 Specification is comprised of up to 13 AirMax VS modules, designated M1 through M13, as shown below.

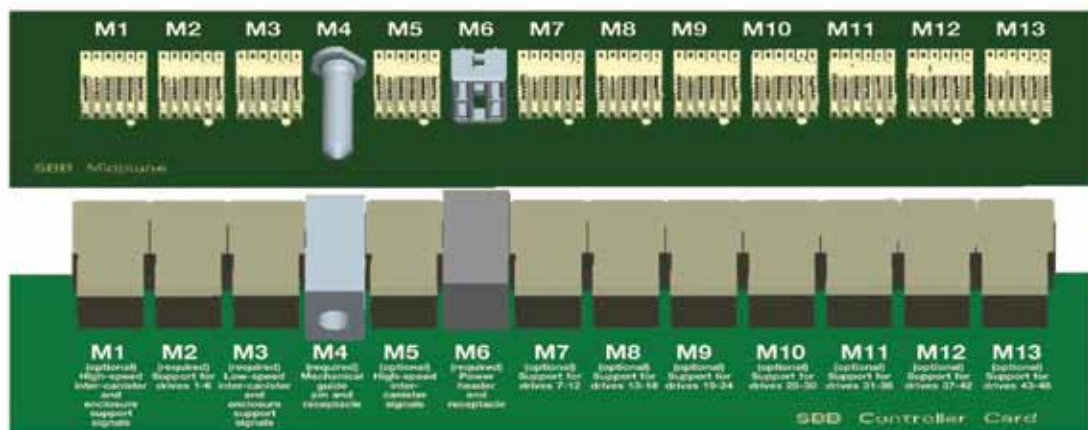

## PART NUMBERS

3 Gb/s SAS Signal Profile	Module Description	SBB Midplane	SBB Canister / Controller Card
AirMax VS 3-pair, 6 IMLA signal modules	M1-M3, M5, M7-M13	10043546-101LF	10039851-101LF
AirMax VS guide module	M4	10037911-102LF	10037912-104LF (with ESD contact) or 10037912-114LF (without ESD contact)
AirMax VS power module	M6	10028916-4555P00LF	10028917-001LF (14.7mm above PCB) or 10073379-001LF (11.5mm above PCB)

2 Gb/s or 4 Gb/s Fibre Channel Signal Profile	Module Description	SBB Midplane	SBB Canister / Controller Card
AirMax VS 3-pair, 6 IMLA signal modules	M1-M3, M5, M7-M13	10043546-101LF	10039851-101LF
AirMax VS guide module	M4	10037911-102LF	10037912-102LF (with ESD contact) or 10037912-112LF (without ESD contact)
AirMax VS power module	M6	10028916-4555P00LF	10028917-001LF (14.7mm above PCB) or 10073379-001LF (11.5mm above PCB)

## AIRMAX VS® 85Ω CONNECTOR SYSTEM

### ENABLES INTEL® QUICK PATH INTERCONNECT (INTEL® QPI) LINKS

#### DESCRIPTION

AirMax VS® 85Ω connectors are optimized to minimize impedance discontinuities and unacceptable signal loss when inserted in 85Ω channels. The connectors' mating interfaces also satisfy demands for backwards compatibility to legacy 100Ω product interfaces ensuring a smooth transition to next-generation designs.

These products have been tested and fully comply with the differential insertion loss, impedance, and crosstalk requirements defined in the Intel® QPI connector specifications. With the Intel® QPI architecture offering transfer rates of 6.4 Gb/s to > 8 Gb/s per lane between processors or processors and I/O controllers, memory bandwidth utilization is significantly lower, enabling multiple bi-directional 10 GbE ports in a server.

Standard connector configurations include vertical and right-angle header and receptacle signal modules to enable backplane and coplanar connections.

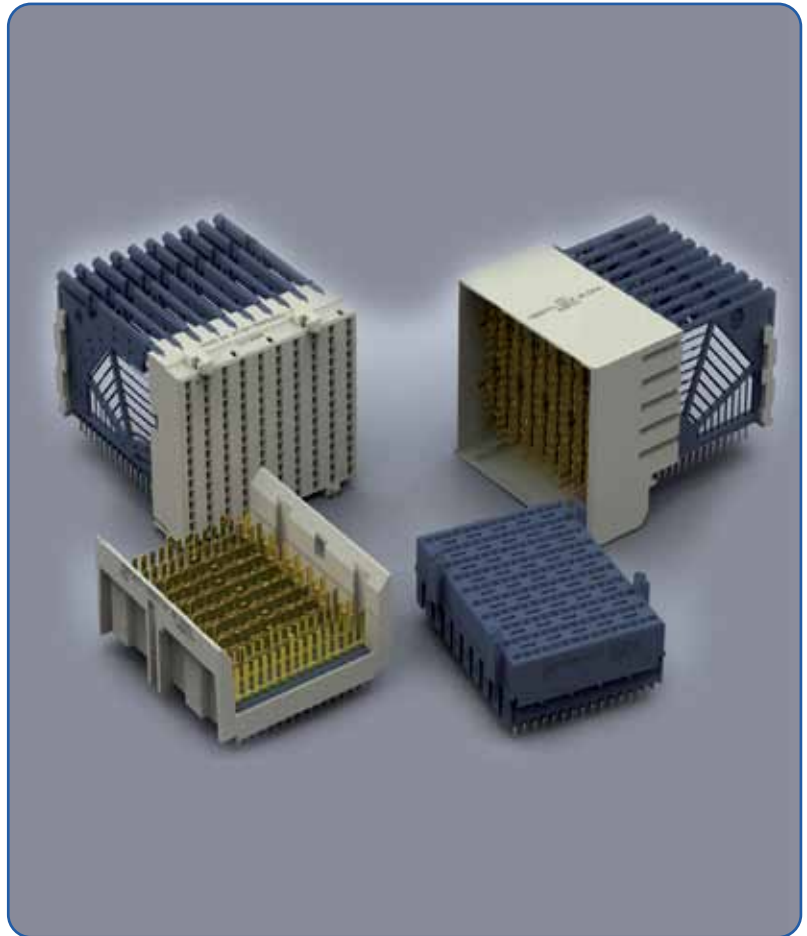

#### FEATURES

- Tested and fully compliant with Intel® QPI connector specifications
- Support increased QPI link speeds of 6.4 Gb/s and >8 Gb/s
- Right-angle and vertical receptacles and headers support backplane and coplanar connections
- Backwards-compatibility to 100Ω mating interfaces provides a smooth transition to new designs
- Available with 2mm or 3mm column spacing
- Complementary power connectors and guide modules complete range
- Compatible with Hard Metric design practice
- Halogen-free products aid efforts to minimize the use of environmentally sensitive materials in the electronics industry

#### TARGET MARKETS / APPLICATIONS

- Data
  - Servers
  - External Storage Systems
  - Intel® QPI links

Intel® is a registered trademark of Intel® Corporation

# AIRMAX VS® 85Ω CONNECTOR SYSTEM

## ENABLES INTEL® QUICK PATH INTERCONNECT (INTEL® QPI) LINKS

### TECHNICAL INFORMATION

#### MATERIALS

- Contacts: Copper Alloy
- Plating: Performance-based plating at separable interface (Telcordia GR-1217 CORE Central Office)
- Housing: High temperature thermoplastic, UL 94V-0

#### ELECTRICAL PERFORMANCE

- Average Differential Impedance: 85Ω± 5 Ωs @ 50ps (10-90%) risetime
- Insertion Loss: <1.5dB through 8 Gbps
- Worst-case Multi-active Near-end Crosstalk: < -30 dB through 8 Gbps
- Worst-case Multi-active Far-end Crosstalk: < -30 dB through 8 Gbps

#### MECHANICAL PERFORMANCE

- Mating force: 0.45N maximum per contact
- Unmating force: 0.15N minimum per contact
- Press-fit insertion force: 40N maximum per compliant tail except for vertical receptacle which is 25N maximum per tail

#### ENVIRONMENTAL

- Per Telcordia Central Office requirements

#### SPECIFICATIONS

- Product Specification: GS-12-239
- Application Specification: GS-12-035

#### APPROVALS AND CERTIFICATIONS

- Telcordia GR-1217-CORE, Central Office
- UL/CSA recognized

#### OTHER SPECIFICATIONS

- Intel® QPI Connector Specifications

#### PACKAGING

- Tubes
- Trays (Vertical receptacle only)

#### ASSOCIATED PRODUCTS

- AirMax VS 100 Ω connector system
- ZipLine® high-density connector system
- Hard-Metric High-Power connectors
- HCI® High-Power connectors
- Guide modules

### PART NUMBERS

Application	Column Pitch	Configuration	Header Type	Right-Angle Header	Vertical Receptacle
Backplane	2mm	5 pairs/column x 10 columns (50 differential pairs)	4-wall	10097311-101LF*	10099767-101LF
Backplane	3mm	5 pairs/column x 10 columns (50 differential pairs)	4-wall	10087771-101LF*	10099768-101LF
Backplane	2mm	3 pairs/column x 6 columns (18 differential pairs)	4-wall	10097256-101LF*	10096461-101LF
Application	Column Pitch	Configuration	Header Type	Vertical Header	Right-Angle Receptacle
Backplane	2mm	5 pairs/column x 10 columns (50 differential pairs)	2-wall	10095500-1050011LF	10095504-101LF
Backplane	3mm	5 pairs/column x 10 columns (50 differential pairs)	2-wall	10073377-1050011LF	10095505-101LF
Application	Column Pitch	Configuration	Header Type	Right-Angle Header	Right-Angle Receptacle
Coplanar	2mm	5 pairs/column x 10 columns (50 differential pairs)	4-wall	10097311-101LF*	10095504-101LF
Coplanar	3mm	5 pairs/column x 10 columns (50 differential pairs)	4-wall	10087771-101LF*	10095505-101LF

Product drawings, specifications and additional technical information are available at [www.fciconnect.com/airmax](http://www.fciconnect.com/airmax)  
 Note: Contact FCI at [airmax@fci.com](mailto:airmax@fci.com) for additional information on these partnumbers.

# AIRMAX VS® HIGH-SPEED CONNECTORS

## FOR SERVER SYSTEM INFRASTRUCTURE (SSI) MODULAR BLADE SERVER PLATFORMS

### DESCRIPTION

The Server System Infrastructure (SSI) Blade Specifications define mechanical, electrical, and management interfaces for blade server platforms to ensure compatibility and interoperability among compute blade modules, compute blade mezzanine modules, chassis management modules, and midplanes or backplanes from a variety of independent vendors.

AirMax VS® high-speed signal connectors, guide modules, and power connectors serve to connect compute blade modules, compute blade mezzanine modules, or chassis management modules to a midplane or backplane in a SSI modular blade server chassis. The high-speed interconnect channels support industry standard technologies such as PCI Express\* Gen 2, Infiniband\* QDR, 8 Gb/s Fibre Channel and IEEE802.3ap\*-2007 "Backplane Ethernet" (10GBASE-KX, 10GBASE-KX4 and 10GBASE-KR).

From its BergStak® 0.8mm product range, FCI can also provide equivalent connectors for the primary and optional expansion interfaces between a compute blade and an optional mezzanine card when an additional high-speed I/O fabric connection to the midplane is needed. The mezzanine connection to the compute blade can support x16, x8, x4, and x1 PCI Express connections.



### FEATURES

- SSI Modular Blade Specifications ensure compatibility and interoperability among compliant modules and midplanes
- AirMax VS 96-position signal modules enable high-speed connections between the Compute Blade and Mezzanine modules and midplane
- AirMax VS 120-position signal modules enable connections between the Chassis Management Module and midplane
- Signal connectors deliver low insertion loss and crosstalk
- High-speed serial data rates can scale to 12.5 Gb/s
- Opposed dual-beam receptacle contact structure provides high reliability
- Compact 2x2 power connectors provide capacity for up to 20A/contact
- Rugged guide modules assure proper alignment
- Compatible with Hard Metric design practice

### TARGET MARKETS / APPLICATIONS

- **Server System Infrastructure (SSI) Modular Blade Server Platforms**
  - Compute Blade Module
  - Mezzanine Module
  - Chassis Management Module (CMM)
  - Midplane
  - Chassis

Product names are trademarks of their respective owners

# AIRMAX VS® HIGH-SPEED CONNECTORS

## FOR SERVER SYSTEM INFRASTRUCTURE (SSI) MODULAR BLADE SERVER PLATFORMS

### TECHNICAL INFORMATION

#### PRODUCT SPECIFICATIONS

- GS-12-239 Press-fit signal connectors
- GS-12-220 Press-fit, high-power connectors

#### APPLICATION SPECIFICATIONS

- GS-20-035 Press-fit signal connectors
- GS-20-023 Press-fit, high-power connectors
- GS-20-045 Hard-metric guide connectors

#### INDUSTRY SPECIFICATIONS

- Server Systems Infrastructure (SSI) Blade Specifications ([www.ssiforum.org](http://www.ssiforum.org))
  - SSI Compute Blade Specification
  - SSI Compute Blade Mezzanine Specification
  - SSI Chassis Management Module Specification
  - SSI Ethernet Midplane Design Guide
- Telcordia GR-1217-CORE, Central Office

### APPLICATION EXAMPLES

- The SSI Compute Blade, Compute Blade Mezzanine, and Chassis Management Module (CMM) connector applications are described below.

Compute Blade with Mezzanine

Chassis Management Module

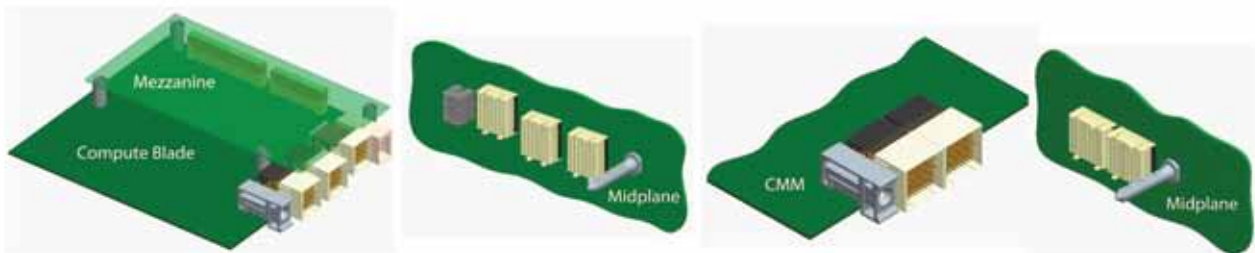

### PART NUMBERS

Compute Blade and Midplane Interface	Compute Blade	Midplane
AirMax VS° 2mm, 4-pair, 96-position signal module	10084604-111LF	10084605-101LF
AirMax VS° 2mm, 4-pair, 96-position signal module (2nd optional signal module)	10084604-111LF	10084605-101LF
AirMax VS° guide module without ESD clip	10084609-111LF	10084610-101LF
AirMax VS° 2x2 power module	10084603-001LF	10084602-4554P00LF
Mezzanine and Midplane Interface	Compute Blade	Midplane
AirMax VS° 2mm, 4-pair, 96-position signal module	10084604-111LF	10084605-101LF
Chassis Management Module (CMM) and Midplane Interface	CMM	Midplane
AirMax VS° 2mm, 4-pair, 120-position signal module	10084600-111LF	10084601-101LF
AirMax VS° 2mm, 4-pair, 120-position signal module	10084600-111LF	10084601-101LF
AirMax VS° guide module without ESD clip	10084609-111LF	10084610-101LF
Compute Blade and Mezzanine Interface	Compute Blade (receptacle)	Mezzanine (plug)
BergStak® 0.8mm, 120-position, 16mm connector	61082-123402LF or 61082-123400LF	61083-124402LF or 61083-124400LF
BergStak® 0.8mm, 80-position, 16mm connector (optional expansion connector)	61082-083402LF or 61082-083400LF	61083-084402LF or 61083-084400LF

Use web links [www.fciconnect.com/airmax](http://www.fciconnect.com/airmax) or [www.fciconnect.com/bergstak](http://www.fciconnect.com/bergstak) to obtain product drawings, models, specifications and additional technical information.

## AIRMAX VS® CONNECTOR SYSTEM

### TRACE ROUTING EXAMPLE – 2.0mm column pitch

		Layout	
		mil	µm
Column Pitch	<b>CP</b>	79.0	2000
Trace	<b>W</b>	8.0	203
Space	<b>S</b>	8.0	203
Pad Diameter	<b>P</b>	36.0	914
Antipad width	<b>Wa</b>	49.0	1245
Total Routing Width	<b>TRW</b>	24.0	610
Annular Ring	<b>Wr</b>	8.2	207
Clearance Drill~Trace	<b>Cd-t</b>	15.7	399
Clearance Pad~Trace	<b>Cp-t</b>	9.5	241
Clearance Antipad~Trace	<b>Ca-t</b>	3.0	76

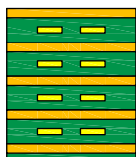
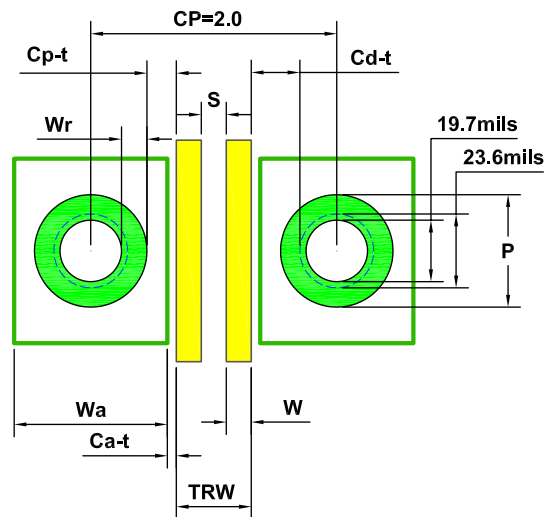

- One differential pair per routing channel (4 high speed signal layers required to route 4 differential pairs)

### TRACE ROUTING EXAMPLE – 3.0mm column pitch

		Layout	
		mil	µm
Column Pitch	<b>CP</b>	118.0	2997
Trace	<b>W</b>	8.0	203
Space	<b>S</b>	8.0	203
Pair~Pair Spacing	<b>Spp</b>	18.0	457
Pad Diameter	<b>P</b>	36.0	914
Antipad width	<b>Wa</b>	48.0	1219
Total Routing Width	<b>TRW</b>	66.0	1676
Annular Ring	<b>Wr</b>	8.2	207
Clearance Drill~Trace	<b>Cd-t</b>	14.2	361
Clearance Pad~Trace	<b>Cp-t</b>	8.0	203
Clearance Antipad~Trace	<b>Ca-t</b>	2.0	51

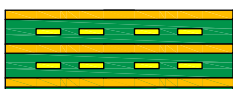
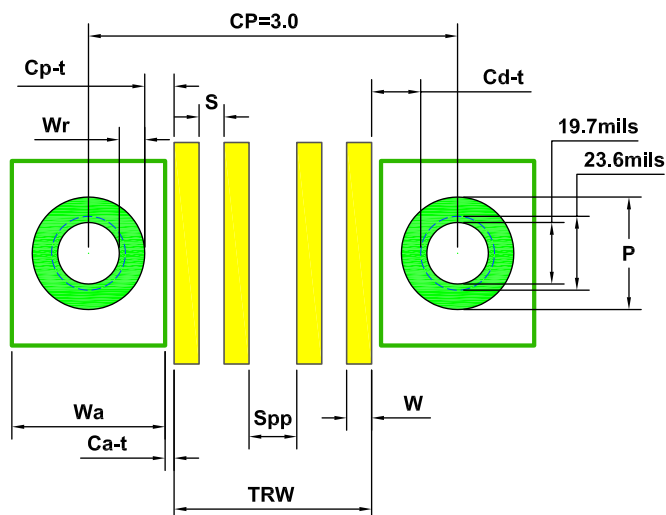

- Three differential pairs per routing channel (Only 2 high speed signal layers required to route 4 differential pairs)

Reference the Application Specification (GS-20-035) for additional guidelines on PCB layouts for AirMax VS connectors including trace routing and pin assignment recommendations for Orthogonal Midplane connectors.



## ZIPLINE® CONNECTOR SYSTEM

### TRACE ROUTING EXAMPLE – 1.8mm column pitch

		Layout	
		mil	µm
Column Pitch	<b>CP</b>	71.0	1803
Trace	<b>W</b>	8.0	203
Space	<b>S</b>	8.0	203
Pad Diameter	<b>P</b>	36.0	914
Antipad width	<b>Wa</b>	43.0	1092
Total Routing Width	<b>TRW</b>	24.0	610
Annular Ring	<b>Wr</b>	8.2	207
Clearance Drill~Trace	<b>Cd-t</b>	11.7	297
Clearance Pad~Trace	<b>Cp-t</b>	5.5	140
Clearance Antipad~Trace	<b>Ca-t</b>	2.0	51

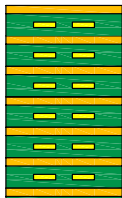
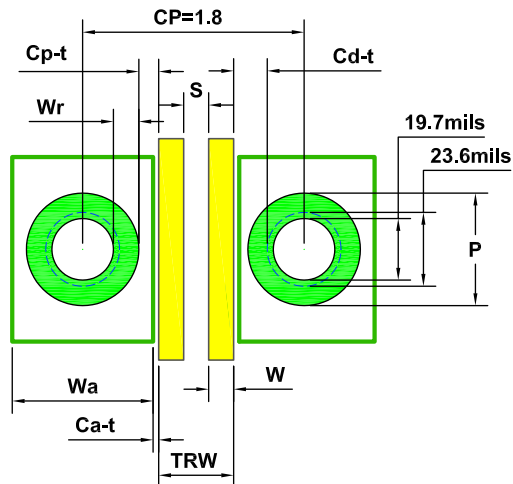

- One differential pair per routing channel (6 high speed signal layers required to route 6 differential pairs)

### TRACE ROUTING EXAMPLE – 3.6mm column pitch

		Layout	
		mil	µm
Column Pitch	<b>CP</b>	142.0	3607
Trace	<b>W</b>	6.0	152
Space	<b>S</b>	6.0	152
Pair~Pair Spacing	<b>Spp</b>	20.0	508
Pad Diameter	<b>P</b>	36.0	914
Antipad width	<b>Wa</b>	43.0	1092
Total Routing Width	<b>TRW</b>	94.0	2388
Annular Ring	<b>Wr</b>	8.2	207
Clearance Drill~Trace	<b>Cd-t</b>	12.2	310
Clearance Pad~Trace	<b>Cp-t</b>	6.0	152
Clearance Antipad~Trace	<b>Ca-t</b>	2.5	64

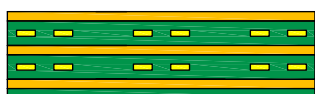
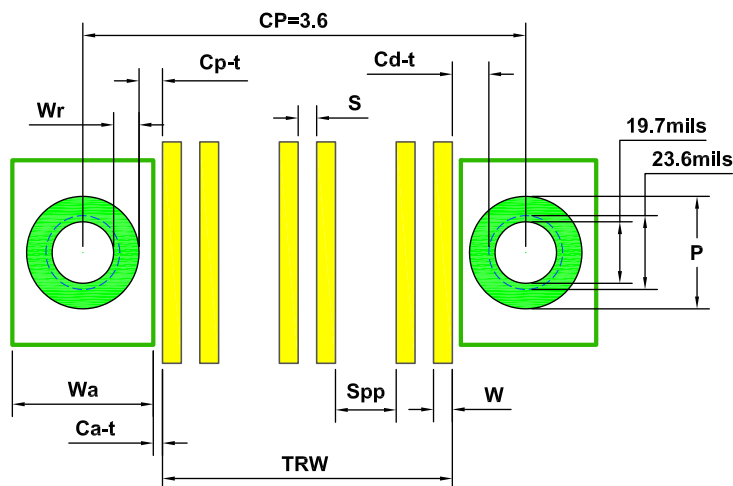

- Two differential pairs per routing channel (Only 2 high speed signal layers required to route 6 differential pairs)

Reference the Application Specification (GS-20-094) and User Guide for Orthogonal Routing (E-3699) for additional guidelines on PCB layouts for ZipLine connectors including trace routing and pin assignment recommendations for Orthogonal Midplane connectors.

# AIRMAX VS® CONNECTOR SYSTEM

## RECEPTACLE TOOLING

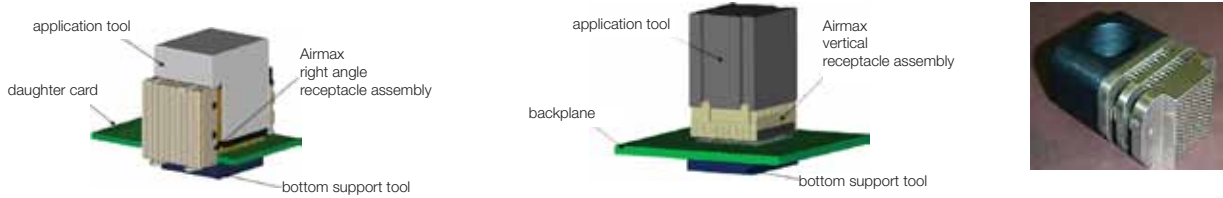

Receptacle Type	Column Pitch (mm)	Module Width (mm)	Insertion Tool Part Numbers		Removal Tool Part Numbers*	
			Right-Angle Receptacle	Vertical Receptacle	Right-Angle or Vertical Receptacles	FCI Manual Number
150 contacts (5 pairs/column)	2.0	20	10041881	430277	430278	430284
150 contacts (5 pairs/column)	3.0	30	10059234	430302	430342	
120 contacts (5 pairs/column)	2.0	16	10050658	430327	430339	
120 contacts (5 pairs/column)	3.0	24	N/A	10071199	10073702	
120 contacts (4 pairs/column)	2.0	20	10058126	430396	10062007	
120 contacts (4 pairs/column)	3.0	30	10058128	430309	430310	
96 contacts (4 pairs/column)	2.0	16	10064163	430397	10062008	
90 contacts (3 pairs/column)	2.0	20	10066103	430352	430354	
72 contacts (4 pairs/column)	2.0	12	N/A	430398	10062009	
72 contacts (3 pairs/column)	2.0	16	N/A	430344	430346	
54 contacts (3 pairs/column)	2.0	12	10058127	430324	430341	
48 contacts (4 pairs/column) Orthogonal	4.2	16.6	10075134	N/A	10080465	

## HEADER TOOLING

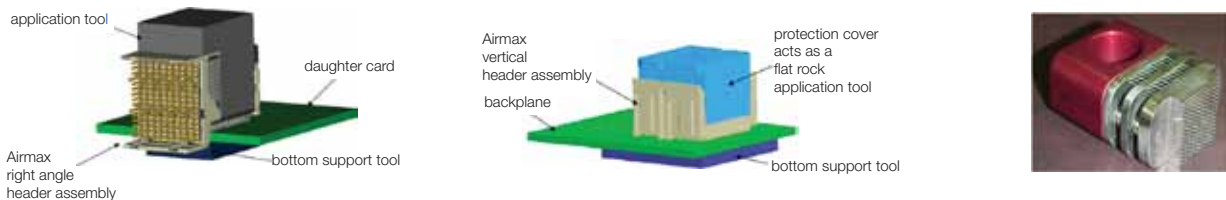

Header Type	Column Pitch (mm)	Module Width (mm)	Insertion Tool Part Number		Removal Tool Part Numbers*	
			Right-Angle Header	Vertical Header	Right-Angle or Vertical Headers	FCI Manual Number
150 contacts (5 pairs/column)	2.0	20 or 22	430276	None required. Protection cover serves as insertion tool	430289	430294
150 contacts (5 pairs/column)	3.0	30 or 32	430301		430333	
120 contacts (5 pairs/column)	2.0	16 or 18	430326		430336	
120 contacts (5 pairs/column)	3.0	24 or 26	10071198		10073501	
120 contacts (4 pairs/column)	2.0	20 or 22	430393		10062004	
120 contacts (4 pairs/column)	3.0	30 or 32	430306		430307	
96 contacts (4 pairs/column)	2.0	16 or 18	430394		10062005	
90 contacts (3 pairs/column)	2.0	20 or 22	430351		430353	
72 contacts (4 pairs/column)	2.0	12 or 14	430395		10062006	
72 contacts (3 pairs/column)	2.0	16 or 18	430343		430345	
54 contacts (3 pairs/column)	2.0	12 or 14	430325		430340	
48 contacts (4 pairs/column) Orthogonal	4.2	16.6	N/A		N/A	

- To minimize costs the largest removal tool for a given column pitch may be used to remove any connector with that column pitch by disassembling the tool and removing pins as necessary.
- A bottom support tool is necessary only if the connector tail length exceeds the board thickness. The tail length specification is 1.60mm +/- 0.15mm. This tool could be a PCB with oversized holes or a custom tool designed by the user.
- Reference the Application Specification (GS-20-035) for additional guidelines.

# ZIPLINE® CONNECTOR SYSTEM

## RECEPTACLE TOOLING

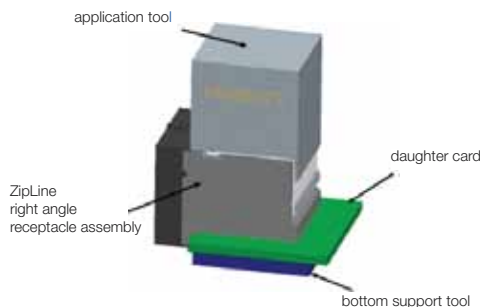

Receptacle Type	Column Pitch (mm)	Module Width (mm)	Insertion Tool Part Numbers	Removal Tool Part Numbers	FCI Manual Number
216 contacts (6 pairs / column)	1.8	21.6	10082873	10082877	10085927
108 contacts (6 pairs / column)	3.6	21.6	10082873		
288 contacts (6 pairs / column)	1.8	28.8	10086892		

## HEADER TOOLING

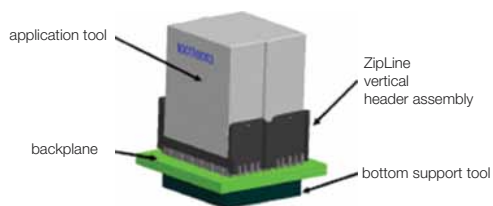

Vertical Header Type	Column Pitch (mm)	Module Width (mm)	Insertion Tool Part Numbers	Removal Tool Part Numbers	FCI Manual Number
216 contacts (6 pairs/column)	1.8	21.6	10078013	10082877	10085927
108 contacts (6 pairs/column)	3.6	21.6	10078013		
288 contacts (6 pairs/column)	1.8	28.8	10085893		

Right-Angle Header Type	Column Pitch (mm)	Module Width (mm)	Insertion Tool Part Numbers	Removal Tool Part Numbers	FCI Manual Number
216 contacts (6 pairs/column)	1.8	21.6	10082873	10082877	10085927

- A bottom support tool is necessary only if the connector tail length exceeds the board thickness. The tail length specification is 1.60mm +/- 0.15mm. This tool could be a PCB with oversized holes or a custom tool designed by the user.
- Reference the Application Specification (GS-20-094) for additional guidelines.

## AIRMAX VS® CONNECTOR SYSTEM

For the most up-to-date and accurate product information, technical data and interactive part number selectors, please visit: [www.fciconnect.com/airmax](http://www.fciconnect.com/airmax) or [www.fciconnect.com/highspeed](http://www.fciconnect.com/highspeed). For further information or inquiries contact FCI at [airmax@fci.com](mailto:airmax@fci.com).

### DATA SHEETS & BROCHURES

- ▶ AirMax VS® & ZipLine® Connector Systems catalog
- ▶ AirMax VS Connector System For Data Applications data sheet
- ▶ AirMax VS Connector System For Telecom Applications data sheet
- ▶ AirMax VS 85-Ohm Connectors for QPI data sheet
- ▶ Storage Bridge Bay (SBB) Application data sheet
- ▶ Server System Infrastructure (SSI) Blade Server Application data sheet
- ▶ Test Procedures and Signal Integrity Performance of the AirMax VS® Product Family brochure
- ▶ Hard Metric High Power Connectors data sheet
- ▶ HCI® High Power Connectors data sheet
- ▶ High Speed & Power Selector flyer

### PRODUCT SPECIFICATIONS

- ▶ AirMax VS Signal Connectors: GS-12-239
- ▶ Hard Metric High Power Connectors: GS-12-220
- ▶ HCI High Power Connectors: GS-12-380

### APPLICATION SPECIFICATIONS

- ▶ AirMax VS Signal Connectors - GS-20-035
- ▶ Guide Modules: GS-20-045
- ▶ Hard Metric High Power Connectors: GS-20-023
- ▶ HCI High Power Connectors: GS-20-070

### TEST REPORTS

- ▶ AirMax VS Backplane Demonstrator BER Test Results
- ▶ AirMax VS 2mm Backplane Demonstrator IEEE 802.3ap Specifications Test Results
- ▶ AirMax VS 3mm Backplane Demonstrator IEEE 802.3ap Specifications Test Results
- ▶ AirMax VS High Speed Connector System Signal Integrity Test Procedures and Performance
- ▶ AirMax VS Orthogonal Signal Integrity Test Data
- ▶ Other Test Reports (contact FCI for copies)
  - ▶ Signal Integrity, Embedded
  - ▶ Signal Integrity, De-Embedded
  - ▶ Lead-Free Repairability
  - ▶ EMI Effectiveness
  - ▶ Performance-Based Plating

### DESIGN TOOLS

- ▶ Products Drawings & 3D Models
- ▶ SPICE Models
- ▶ PCB layout recommendations

### WHITE PAPERS

- ▶ Lucent Technologies: Scalability of Duobinary Signaling of 25 Gb/s for 100GbE Applications
- ▶ Accelerant Networks: A 40 Gb/s Backplane Reference Design
- ▶ FCI & Endicott Interconnect Technology: A Next Generation Backplane Design
- ▶ FCI & Marvell: AirMax VS® at 2.5 Gb/s
- ▶ FCI & Maxim: 10 Gb/s using AirMax VS® and MAX 3850
- ▶ FCI & Mitsubishi Electric: a 10 Gb/s Demonstration System
- ▶ FCI & Thin Film Technology Corporation: 10 Gb/s with Equalized Connectors
- ▶ Sanmina-SCI: Custom AirMax VS® @ ATCA® Backplane
- ▶ FCI & Xilinx: 10 Gb/s NRZ Demonstrator Backplane
- ▶ FCI & Northrop Grumman Interconnect Technologies : 10 Gb/s NRZ Demonstrator Backplane
- ▶ FCI & W.L. Gore : AirMax VS® 2mm 4-Pair I/O Demonstrator
- ▶ FCI: AirMax VS connector system – the secret of minimizing crosstalk without costly shields
- ▶ FCI: Effect of Nanosecond Electrical Discontinuities in High-Speed Digital Applications
- ▶ FCI: DesignCon 2007 - Comparison of S-Parameter Concatenation to Full-Wave Simulation for High-Speed Interconnect Analysis
- ▶ FCI & Intel: DesignCon 2007 - Improving System Performance by Reducing System Impedance to 85 Ohms

## ZIPLINE® CONNECTOR SYSTEM

For the most up-to-date and accurate product information, technical data and interactive part number selectors, please visit: [www.fciconnect.com/zipline](http://www.fciconnect.com/zipline) or [www.fciconnect.com/highspeed](http://www.fciconnect.com/highspeed). For further information or inquiries contact FCI at [zipline@fci.com](mailto:zipline@fci.com).

### DATA SHEETS & BROCHURES

- ZipLine® High-Density, High-Performance Connector System data sheet
- AirMax VS® & ZipLine® Connector Systems catalog
- Hard Metric High-Power Connectors data sheet
- HCI® High Power Connectors data sheet
- High Speed & Power Selector flyer

### PRODUCT SPECIFICATIONS

- Zipline Signal Connectors: GS-12-452
- Hard Metric High Power Connectors: GS-12-220
- HCI High Power Connectors: GS-12-380

### APPLICATION SPECIFICATIONS

- Zipline Signal Connectors - GS-20-094
- Guide Modules: GS-20-045
- Hard Metric High Power Connectors: GS-20-023
- HCI High Power Connectors: GS-20-070

### TEST REPORTS

- Zipline BER Test Results
- Zipline Channel BER Customer Report
- Zipline Orthogonal SI Test Data (opposing modules rotated 90 Degrees)
- Zipline Orthogonal SI Test Data (opposing modules rotated 270 Degrees)

### DESIGN TOOLS

- Product Drawings & 3D Models
- Zipline Orthogonal Routing Guides

### WHITE PAPERS

- FCI: Comparison of S-Parameter Concatenation to Full-Wave Simulation for High-Speed Interconnect Analysis
- FCI: Effect of Nanosecond Electrical Discontinuities in High-Speed Digital Applications

Product Number	page
430276	34
430277	34
430278	34
430284	35
430289	34
430294	35
430301	34
430302	34
430306	34
430307	34
430309	34
430310	34
430324	34
430325	34
430326	34
430327	34
430333	34
430336	34
430339	34
430340	34
430341	34
430342	34
430343	34
430344	34
430345	34
430346	34
430351	34
430352	34
430353	34
430354	34
430393	34
430394	34
430395	34
430396	34
430397	34
430398	34
10041881	34
10050658	34
10058126	34
10058127	34
10058128	34
10059234	34
10062004	34
10062005	34
10062006	34
10062007	34
10062008	34
10062009	34
10064163	34

Product Number	page
10066103	34
10071198	34
10071199	34
10073501	34
10073702	34
10075134	34
10078013	34
10078270	34
10080464	34
10080465	34
10082873	35
10082877	35
10085893	34
10085927	35
10086892	35
10016527-101LF	8, 16
10016537-101LF	8, 18
10025613-101LF	8, 16
10028264-101LF	8, 18
10028436-101LF	8, 16
10028916-4444P00LF	10, 23
10028916-4455P00LF	10, 23
10028916-4554P00LF	10, 23
10028916-4555P00LF	10, 23, 27
10028916-5554P00LF	10, 23
10028916-5555P00LF	10, 23
10028917-001LF	17, 23, 27
10028918-001LF	10, 23, 27
10029391-101LF	8, 16
10034249-101LF	8, 16
10034251-101LF	8, 18
10034264-101LF	8, 16
10034475-101LF	9, 16
10035146-101LF	8, 18
10035465-101LF	8, 18
10035514-101LF	8, 16
10035515-101LF	8, 16
10035754-101LF	9, 16
10037323-101LF	8, 16
10037324-101LF	8, 16
10037908-101LF	11, 21
10037909-101LF	11, 17, 21
10037910-1xxLF	11, 21
10037911-102LF	27
10037911-1xxLF	11, 21
10037912-102LF	27
10037912-104LF	27
10037912-112LF	27
10037912-114LF	27



Product Number	page
10037912-1xyLF	11, 17, 21
10037915-101LF	11, 21
10039851-101LF	8, 16, 27
10040862-101LF	8, 16
10040993-101LF	8, 18
10041268-1010031LF	19
10041398-101LF	19
10041460-101LF	8, 16
10041746-101LF	8, 16
10043546-101LF	8, 18, 27
10044314-101LF	17, 21
10044366-10yLF	17, 21
10045266-101LF	8, 16
10045267-101LF	8, 16
10045271-101LF	8
10045367-101LF	11, 17, 21
10045368-101LF	11, 21
10045509-10yLF	17, 21
10045548-101LF	9, 16
10045588-101LF	17, 21
10045597-1xyLF	11, 17, 21
10045722-101LF	9, 16
10052620-4444P00LF	17, 23
10052620-4554P00LF	17, 23
10052620-4555P00LF	17, 23
10052620-5455P00LF	17, 23
10052824-101LF	8
10052825-101LF	8
10052829-101LF	8
10052837-101LF	8, 16
10052838-101LF	8, 16
10052842-101LF	8, 18
10053656-101LF	9, 16
10055140-1050011LF	9, 18
10055307-1050011LF	9, 18
10056098-1050011LF	9, 18
10056100-1050011LF	9, 18
10056100-1080011LF	18
10056101-1050011LF	9, 18
10056103-1050011LF	9, 18
10056246-1071LF	18
10056335-101LF	9, 16
10056427-1050011LF	9, 18
10056429-1050011LF	9
10056430-1050011LF	9, 18
10056430-1080011LF	9, 18
10057041-101LF	9, 16
10059957-1071LF	18
10060905-101LF	9, 16

Product Number	page
10061289-001LF	10, 23, 24
10061290-545555PLF	10, 23
10061399-101LF	19
10064488-101LF	8
10064489-101LF	8
10064493-101LF	8
10066832-101LF	11, 21
10073377-1050011LF	9, 29
10073379-001LF	10,17,23,27
10073718-101LF	12
10074050-101LF	12
10076197-101LF	9
10076209-101LF	9, 13
10076222-101LF	13
10076645-101LF	9
10077323-101LF	16
10077555-101LF	16
10078550-101LF	9,13
10078557-101LF	9,13
10078768-001LF	10, 24
10078770-001LF	10, 24
10078902-001LF	10, 24
10078904-001LF	10, 24
10080638-101LF	9
10080640-101LF	13
10084155-101LF	9, 13
10084160-101LF	13
10084186-101LF	9
10084600-111L	31
10084601-101LF	31
10084602-4554P00LF	31
10084603-001LF	31
10084604-111LF	31
10084605-101LF	31
10084609-111LF	31
10084610-101LF	31
10087771-101LF	8, 16, 29
10087937-001LF	10,24
10087939-001LF	10, 24
10095500-10500111LF	9, 29
10095504-101LF	9, 16, 29
10095505-101LF	9, 16, 29
10096461-101LF	8, 29
10097256-101LF	8, 29
10097311-101LF	8, 16, 29
10099767-101LF	8, 29
10099768-101LF	8, 29
61082-083400LF	31
61082-083402LF	31

Product Number	page
61082-123400LF	31
61082-123402LF	31
61083-084400LF	31
61083-084402LF	31
61083-124400LF	31
61083-124402LF	31

For more information about e-catalog or FCI  
sales offices, headquarters, agents and local distributors,  
visit [www.fciconnect.com](http://www.fciconnect.com)



Americas - Phone: 1 (800) 237 2374  Europe - - Phone: 33 1 39 49 21 83  Asia/Pacific - Phone: 65 6549 6666

ELXAIRMZIPL0110EA4