

## Priming the Pump

To prime the pump:

1. Before making any connections to the pump remove the filler cap (item ⑧) and fill the reservoir approximately 2/3 with either distilled water, mineral oil, or hydraulic oil 32 (10 W), and re-install the filler cap until finger tight.
2. Adjust the "Vernier" knob (item ④) to the approximate mid-range.
3. Fully open the pressure bleed knob (item ⑨), turning counterclockwise until it stops.
4. Hold the pump at a 45 degree angle, with the reservoir facing up, as shown in the figure "Using the Test Pump."
5. Pump the handle until fluid appears, then close the pressure bleed knob.
6. Attach the hose and fill by pumping until fluid begins to flow.
7. Attach the hose to the Unit Under Test (UUT), make sure to plug any unused ports on the pump, and continue to compress the handle until pressure is created.

### Note

*It may take many compressions of the handle to create pressure depending on hose length and volume of the UUT.*

8. Open the pressure bleed knob to release pressure and any air trapped in the line until all of the air in the line is bled off. Repeat if necessary.
9. When testing is complete, disconnect the hose from the unit under test. If using the Fluke HTH hose, place the plastic sealing cap back over the exposed end of the hose to help retain the fluid until the pump is used again. Retaining the fluid in the hose will greatly reduce the number of strokes required to re-prime the pump.

## Replacement Parts

Rebuild Kit, Fluke PN 2812606

Hydraulic Fluid Reservoir Rebuild Kit, Fluke PN 2844341

Handle Assembly Rebuild Kit, Fluke PN 2844352

### LIMITED WARRANTY AND LIMITATION OF LIABILITY

This Fluke product will be free from defects in material and workmanship for one year from the date of purchase. This warranty does not cover fuses, disposable batteries, or damage from accident, neglect, misuse, alteration, contamination, or abnormal conditions of operation or handling. Resellers are not authorized to extend any other warranty on Fluke's behalf. To obtain service during the warranty period, contact your nearest Fluke authorized service center to obtain return authorization information, then send the product to that Service Center with a description of the problem.

THIS WARRANTY IS YOUR ONLY REMEDY. NO OTHER WARRANTIES, SUCH AS FITNESS FOR A PARTICULAR PURPOSE, ARE EXPRESSED OR IMPLIED. FLUKE IS NOT LIABLE FOR ANY SPECIAL, INDIRECT, INCIDENTAL OR CONSEQUENTIAL DAMAGES OR LOSSES, ARISING FROM ANY CAUSE OR THEORY. Since some states or countries do not allow the exclusion or limitation of an implied warranty or of incidental or consequential damages, this limitation of liability may not apply to you.

Fluke Corporation  
P.O. Box 9090  
Everett, WA 98206-9090  
U.S.A.

Fluke Europe B.V.  
P.O. Box 1186  
5602 BD Eindhoven  
The Netherlands

11/99

# FLUKE®

## Fluke-700HTP-1 Hydraulic Test Pump

### Instruction Sheet

## Introduction

The Fluke-700HTP-1 Hydraulic Test Pump (hereafter called the pump) is a portable source of high pressure. The pump has the following specifications:

- Maximum pressure: 690 bar (10,000 psi)
- Hydraulic media: distilled water, mineral based hydraulic oil, or hydraulic oil 32 (10 W).
- Wetted materials: 303 stainless steel, aluminum, polyurethane, PTFE, nitrile, and nylon
- Weight: 1.29 lb (0.58 kg)
- Dimensions: length 9.5 in (241 mm), width 6.1 in (155 mm), depth 2.6 in (66 mm)

## Box Contents

- Model 700HTP-1 Hydraulic Test Pump with 1/4 in NPT tee installed
- (2) 1/4 in NPT male to 1/4 in BSP female adapter
- 1/4 in NPT male to 1/4 in NPT male fitting
- Instruction Sheet

## Contacting Fluke

To contact Fluke or for service, call one of the following telephone numbers:

USA: 1-888-44-FLUKE (1-888-443-5853)

Canada: 1-800-36-FLUKE (1-800-363-5853)

Europe: +31 402-675-200

Japan: +81-3-3434-0181

Singapore: +65-738-5655

Anywhere in the world: +1-425-446-5500

Or, visit Fluke's Web site at [www.fluke.com](http://www.fluke.com).

PN 2811836

April 2007 Rev.1, 11/08

©2007, 2008 Fluke Corporation. All rights reserved. Printed in U.S.A.

All product names are trademarks of their respective companies.

## Features

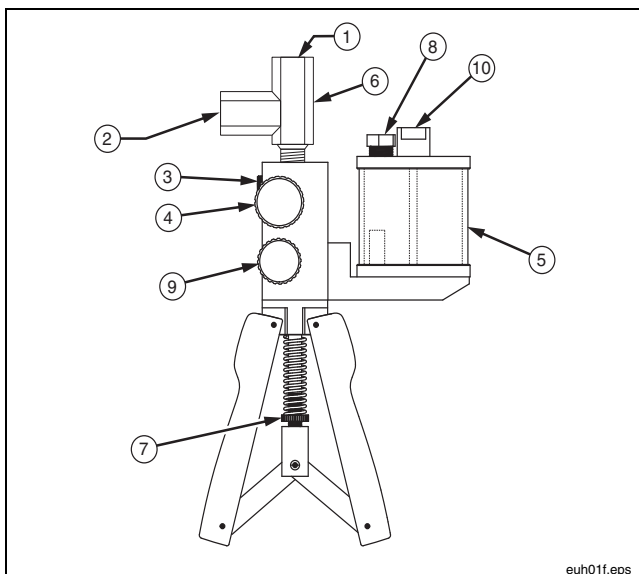

euH01f.eps

No.	Item	Function
①	Master instrument port	Port for Fluke 700 Series Pressure Module, 1/4 in NPT female
②	Test pressure port	Port for pressure instrument under test, 1/4 in NPT female
③	Pressure relief valve port	Port for an optional Fluke 700PRV-1 Pressure Relief Valve (plugged)
④	Fine adjustment knob	Allows you to precisely adjust the applied pressure
⑤	Hydraulic fluid reservoir	Holds 100 cc of hydraulic fluid: mineral based hydraulic oil, distilled water, or hydraulic oil 32 (10 W).
⑥	1/4 NPT tee	For master and test ports
⑦	Stroke adjust	Use to adjust handle stroke
⑧	Reservoir filler plug	Remove this to fill hydraulic fluid reservoir. Reseal before you pump.
⑨	Pressure bleed knob	Allows you to release pressure in a controlled manner
⑩	Reservoir nut	Remove nut to clean reservoir

## Using the Test Pump

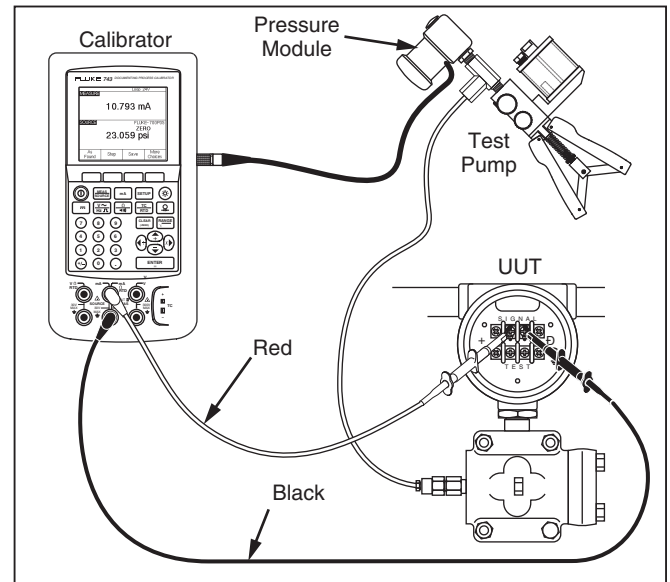

euH02c.eps

### ⚠ Warning

To avoid a violent release of pressure, always depressurize the system slowly using the pressure bleed knob (item ⑨, left) before you detach any pressure line from the pump. Do not connect the pump to an external pressure source.

### ⚠ Caution

If you are using the pump with a pressure module or pressure instrument that will be damaged by pressures of 690 bar (10,000 psi), you can protect the equipment by installing a properly set relief valve in the system or an optional Fluke 700PRV-1 Pressure Relief Valve on the pump.

1. Attach a 700 Series Pressure Module (hereafter called "pressure module") to the master instrument port ① for all modules except the 700P High Pressure Modules. To adapt to the 700P29, P30, or P31 Series High Pressure Modules, install a male 1/4-in NPT Adapter. Use Teflon tape or other sealing media on NPT thread connections to eliminate leaks.
2. Remove fill cap and fill reservoir approximately 2/3 full.
3. Connect the pressure module to the calibrator as shown in the figure.
4. Connect the input of the pressure instrument under test to the test pressure port (item ②).
5. Unscrew the pressure bleed knob (item ⑨) to vent pressure from the pump.
6. Zero the pressure module. The zeroing procedure depends on which pressure module and calibrator you are using.
7. Turn the fine adjustment knob (item ④) to mid-range.
8. Tighten the pressure bleed knob finger tight.
9. Set the handle stroke length to maximum.
10. Prime pump as described under "Priming the Pump".
11. Shorten handle-stroke length to reduce pumping force.

### ⚠ Caution

Pressure may rise rapidly if the pressurized volume is small.

12. Compress the handles to apply incrementally higher pressure.
13. For fine pressure adjustment, use the fine adjustment knob.