

Future Technology Devices International

Datasheet

MM900EVxA Development Module

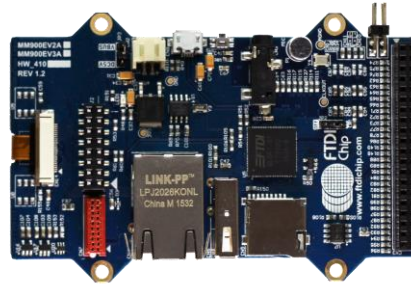

FT90X Family is a General Purpose 32-bit Microcontroller

1 Introduction

The MM900EVxA Series is a development module for FTDI's 32-bit high performance FT90x Microcontroller family, which is used to develop and demonstrate the functionality of the FT90x Embedded Microcontroller.

These modules apply to home security systems, home automation systems, USB capability products, embedded multimedia application and other industrial control systems.

There are 3 development modules for selection:

- MM900EV1A, without VGA camera module.
- MM900EV2A, with front facing VGA camera module and two RGB LEDs.
- MM900EV3A, with rear facing VGA camera module and two RGB LEDs.

1.1 Features

For a full list of the FT90x' features refer to the [FT90x datasheet](#). In addition, the MM900EVxA series has the following features:

- FT900 100-pin QFN package microcontroller.

- RJ45 with built in magnetic for 10/100Mbps Ethernet transfer.
- Micro SD card socket support.
- A Standard USB-A connector to support USB device connection.
- A Micro-B USB for connecting to a USB host or providing a power supply over USB for the board.
- Audio codec embedded on board with a microphone input, 3.5mm headphone jack and speakers stereo output.
- 2x8 pins 2.54mm pitch dual entry female header and 16 pins 0.5mm pitch FFC/FPC connectors for SPI master to support LCD display modules.
- 2x5 pins 1.27mm pitch female Micro-Match connector for software download and debug.
- 2x20 pins 2.54mm pitch female header support for external feature expansions.
- RTC with coin cell capacitor support.
- 24 pins 0.5mm pitch camera connector and two RGB LEDs (MM900EV2A/3A modules).
- +5V alternative power supply DC connector.
- Hardware Reset button provided.

Neither the whole nor any part of the information contained in, or the product described in this manual, may be adapted or reproduced in any material or electronic form without the prior written consent of the copyright holder. This product and its documentation are supplied on an as-is basis and no warranty as to their suitability for any particular purpose is either made or implied. Future Technology Devices International Ltd will not accept any claim for damages howsoever arising as a result of use or failure of this product. Your statutory rights are not affected. This product or any variant of it is not intended for use in any medical appliance, device or system in which the failure of the product might reasonably be expected to result in personal injury. This document provides preliminary information that may be subject to change without notice. No freedom to use patents or other intellectual property rights is implied by the publication of this document. Future Technology Devices International Ltd, Unit 1, 2 Seaward Place, Centurion Business Park, Glasgow G41 1HH United Kingdom. Scotland Registered Company Number: SC136640

2 Ordering Information

Part No.	Description
MM900EV1A	FT90x module, a 32-bit FT32 microcontroller with 256kB flash memory, 64kB data RAM and 256kB program memory embedded. 10/100Mbps Ethernet, SD3.0, USB2.0 Host and Device, Audio codec, several interface pin headers and connectors included. Without camera.
MM900EV2A	FT90x module, a 32-bit FT32 microcontroller with 256kB flash memory, 64kB data RAM and 256kB program memory embedded. 10/100Mbps Ethernet, SD3.0, USB2.0 Host and Device, Audio codec, several interface pin headers and connectors included. With front facing camera.
MM900EV3A	FT90x module, a 32-bit FT32 microcontroller with 256kB flash memory, 64kB data RAM and 256kB program memory embedded. 10/100Mbps Ethernet, SD3.0, USB2.0 Host and Device, Audio codec, several interface pin headers and connectors included. With rear facing camera.

Table 2-1 – Ordering information

3 Program Support

Example applications are provided for MM900EVxA modules by FTDI.

The following documents provide further details for software development.

Other relevant documents and examples exist so please see the [FTDI website](#) for further information.

[AN_324_FT900_User_Manual](#) for system registers information.

[AN_365_FT900_API_Programmers_Manual](#) for using FT90x Peripheral Driver Library.

[AN_360_FT90x_Example_Applications](#) for some simple example applications.

Table of Contents

1	Introduction	1
1.1	Features	1
2	Ordering Information	2
3	Program Support	3
4	Board Layout	6
4.1	Power Supply	7
4.2	Microcontroller	8
4.3	Micro SD Connector	9
4.4	USB Connector	9
4.5	10/100Mbps Ethernet Connector	11
4.6	Programmer Interface	12
4.6.1	CN7 – 10-pin Micro-Match Program Interface Signals	12
4.7	SPI Master Interface	14
4.7.1	J2 – 16-pin Dual Entry Header, SPI Master and Control Signals	15
4.7.2	CN12 – 16-pin FPC/FFC connector	16
4.8	Audio codec	17
4.8.1	Microphone Input	17
4.8.2	Audio Output	18
4.9	Camera connector	19
4.10	RGB LEDs	20
4.11	RTC	21
4.12	External I/O Bus	22
5	Board Schematic	25
6	Mechanical Dimensions	31
6.1	MM900EV1A PCB Dimensions	31
6.2	MM900EV2A/3A PCB Dimensions	32
7	Contact Information	33
Appendix A - References		33
Document References		33
Acronyms and Abbreviations		33
Appendix B - List of Figures and Tables		35
List of Figures		35

List of Tables	35
Appendix C – Revision History.....	37

4 Board Layout

The MM900EV1A development board is a 55 mm x 85 mm (Not including the 4 mounting holes) six-layer printed circuit board. The layout is as shown in Figure 4-1.

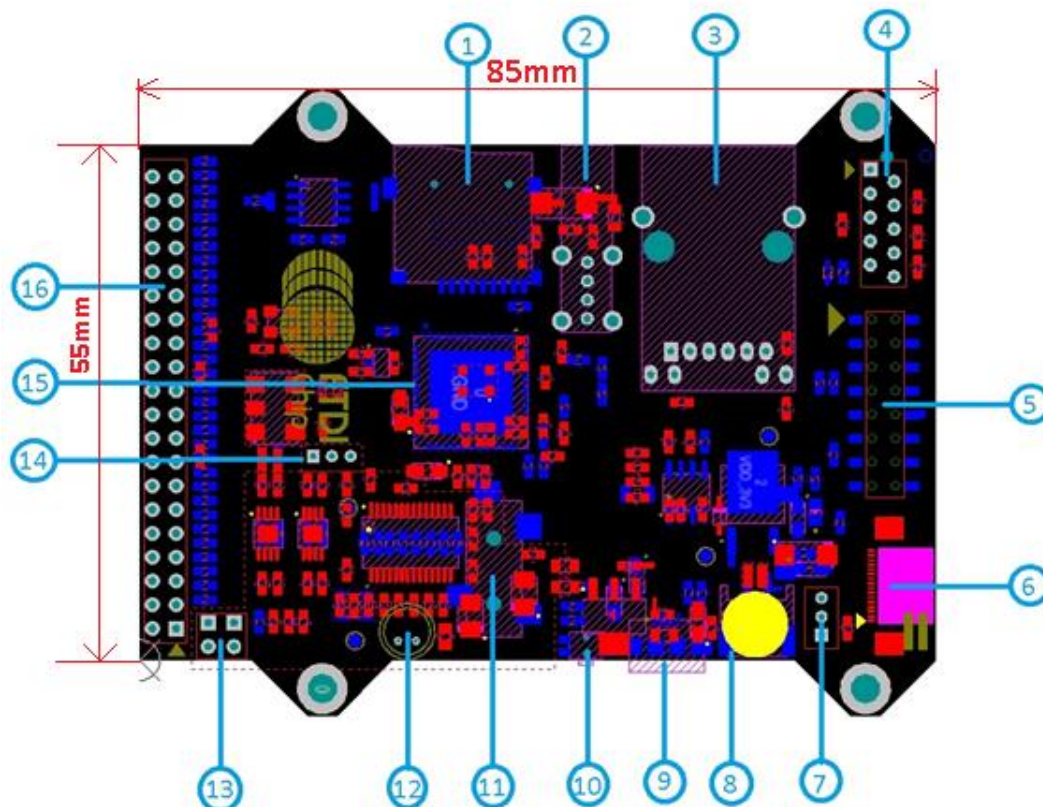

Figure 4-1 – MM900EV1A Board Layout

Key Features: (For all MM900EVxA series boards)

- | | |
|--------------------------------------|--|
| 1. Micro SD card socket | 9. USB Micro-B connector |
| 2. USB Standard A vertical connector | 10. H/W Reset button |
| 3. Ethernet port | 11. Headphone 3.5mm stereo jack |
| 4. Program interface | 12. Microphone |
| 5. Dual-entry SPI master pin header | 13. Two speakers pin header |
| 6. SPI master FPC/FFC connector | 14. Audio output jumper |
| 7. Alternative power supply jumper | 15. FT900 QFN Microcontroller |
| 8. DC power socket | 16. External I/O bus female pin header |

The MM900EV2A/3A development boards are 55 mm x 100 mm (not including the 4 mounting holes) six-layer printed circuit boards. The layout is as shown in Figure 4-2.

The MM900EV2A and MM900EV3A both use the same bare PCB as the only difference is the position of the camera.

The MM900EV2A is supplied with a front facing camera module which is inserted into **CN13** (24-pin FFC/FPC 0.5mm pitch, bottom contact connector) and has two configurable colour RGB LEDs fitted at **U8** and **U9**.

MM900EV3A is supplied with a rear facing camera module which is inserted into **CN14** (24-pin FFC/FPC 0.5mm pitch, bottom contact connector) and has two configurable colour RGB LEDs fitted at **U18** and **U19**.

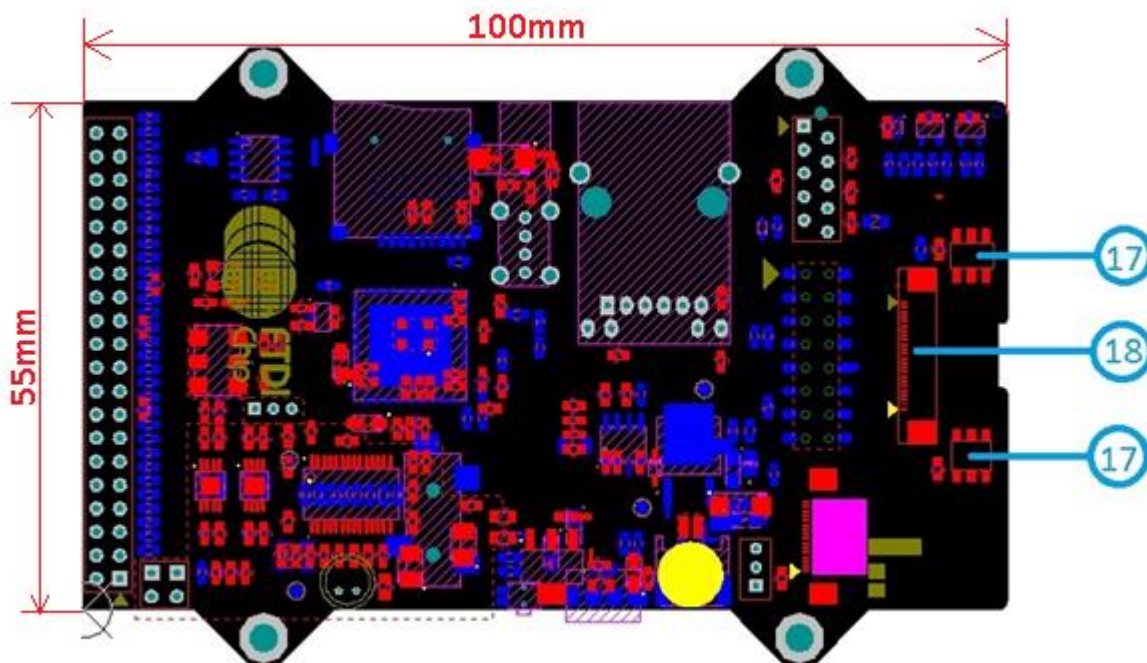

Figure 4-2 – MM900EV2A/3A Board Layout

Key Features: (For MM900EV2A/3A board only)

17. Two RGB LEDs

18. VGA camera module FPC/FFC connector

4.1 Power Supply

The MM900EVxA development boards provide optional power supply sources with **JP3** jumper:

1. 5V DC power supply, **CN2** right angle connector.
2. Via the USB Micro-B USB **CN8** port.

Pin No.	Name
1-2	USB VBUS power supply
2-3	5V DC power supply

Table 4-1 – JP3 Pinout

A red LED (Led1) will illuminate after the 5V power supply is applied. This supply will also drive a fixed 3.3V LDO regulator which will power to all peripherals of the FT900 microcontroller.

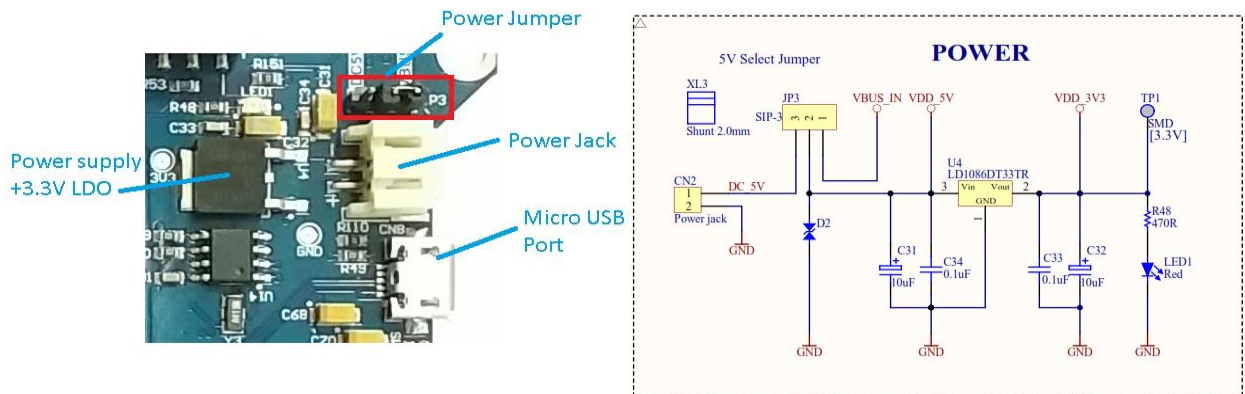

Figure 4-3 – Power supply

4.2 Microcontroller

The FT900 100-pin QFN microcontroller (U5) provided on the board belongs to the 32-bit FT90X Microcontroller family from FTDIChip. For details of the FT90X Microcontroller, refer to the [FT90X datasheet](#).



Figure 4-4 – FT900 Microcontroller

There are two crystals used on the MM900EVxA development boards. The 12MHz crystal is the primary system clock frequency supplying the FT900 IC, while the other 32.768 KHz oscillator is used by the on-chip Real Time Clock (RTC). The RTC oscillator is disabled on board by default –see section 4.11 for details.

The FT900 IC on this board is operated with a single supply of 3.3V. The FT900 Core 1.2V (VOUT1) and Ethernet Regulator 1.2V (VOUT2) sources are unused. These power output pins have decoupling capacitors as specified in the datasheet.

4.3 Micro SD Connector

The FT900 Microcontroller has a SD3.0 controller to support different speed classes, physical sizes and capacities of Secure Digital (SD) cards. There is a Micro SD connector on the MM900EVxA development modules for inserting Micro SD cards (11 x15 x1.0 mm).

There are three standard capacity cards supported:

- Secure Digital (SD) standard – Up to 2GB SD memory card
- Secure Digital High Capacity (SDHC) standard – Over 2GB-32GB SDHC memory card
- Secure Digital extended Capacity (SDXC) standard – Over 32GB-2TB SDXC memory card

Standard class speeds 2, 4, 6, 10, and Ultra High Speed (UHS) classes U1 and U3 are all supported. The design of the physical interface supports 4-bit SD bus mode and card detection.

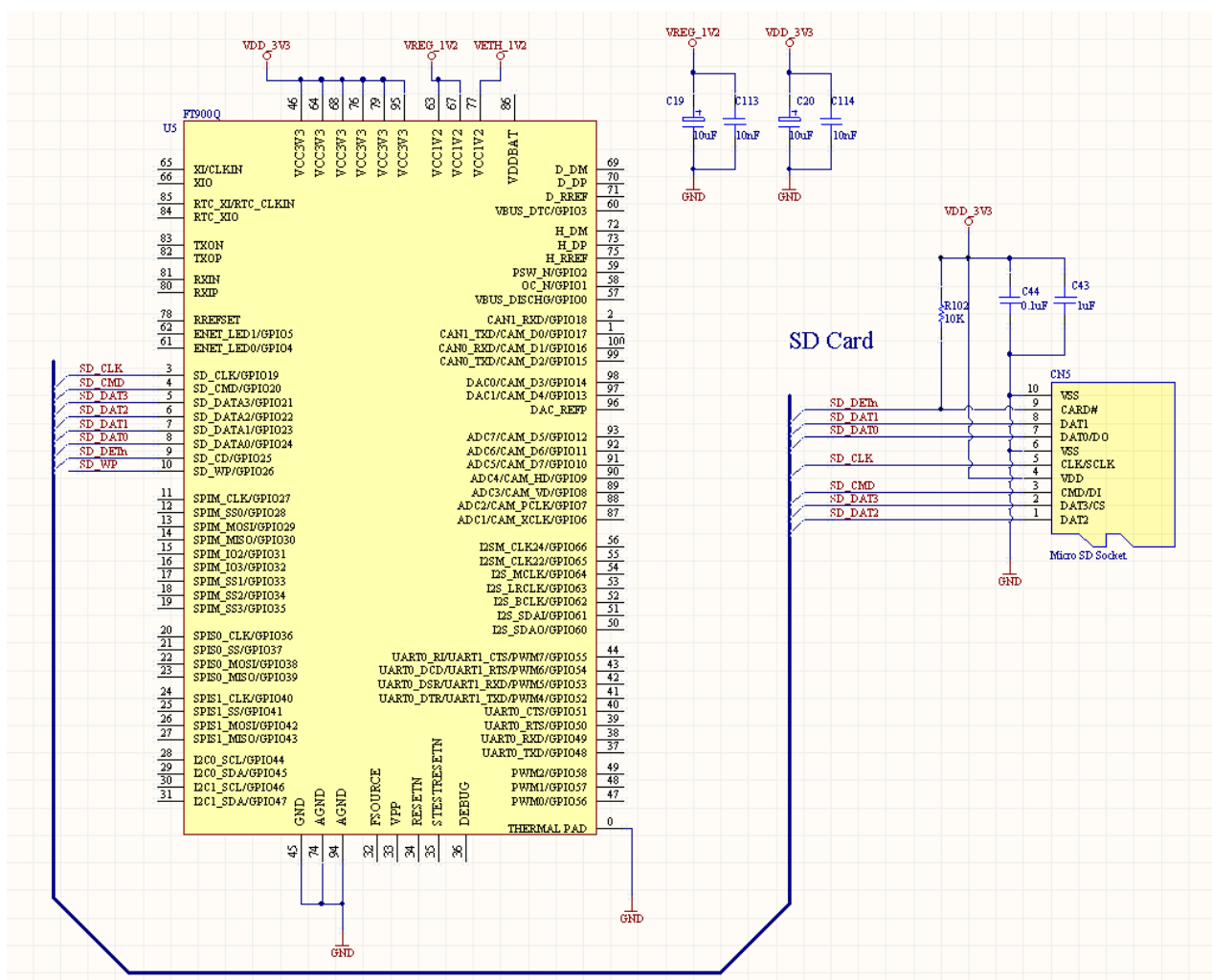

Figure 4-5 – Micro SD Connector

4.4 USB Connector

There are two USB connectors provided on the MM900EVxA series board. One **CN8** is a Micro-B type USB2.0 connector which is used for connecting to a USB host, while the other **CN6** is Standard-A type vertical USB2.0 connector which serves as a USB2.0 host connector.

The USB2.0 host port is an EHCI specification compatible port to support hi-speed, full-speed and low-speed data transfer with USB devices. There is also a power switch **U7** for the VBUS power supply which provides over current protection on board.

The USB differential impedance for DP and DM signals on the USB device and USB host ports is controlled via the PCB layout.

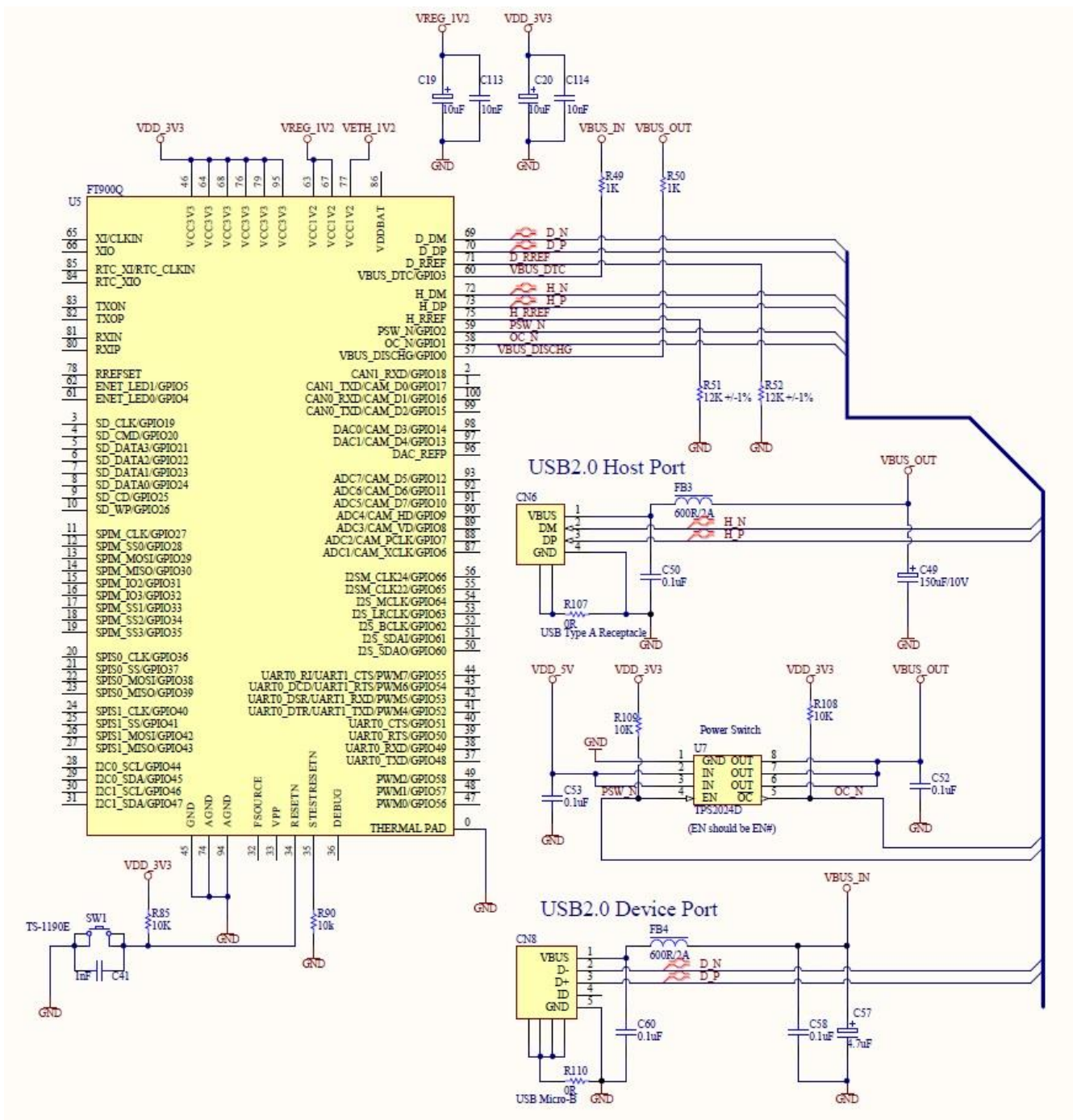

Figure 4-6 – USB Connectors

4.5 10/100Mbps Ethernet Connector

An RJ45 Ethernet Jack (**CN4**) with built in transformer (magnetics), status LEDs and shielding is provided for 10/100 BASE-T applications on the MM900EVxA development modules. The FT900 microcontroller has an IEEE802.3 specification compatible Ethernet interface, with integrated MAC and PHY, which provides standard communication with a network over Ethernet.

For signal integrity, Ethernet differential impedance is controlled on the MM900EVxA development board in the PCB layout. 50ohm +/-10% impedance of TX & RX signals to ground and 100ohm +/-10% differential impedance between TX_N and TX_P, or RX_N and RX_P.

MM900EVxA development modules provide a unique 48-bit MAC address for Ethernet applications, which can be accessed on the 256 EEPROM **U6** via I²C serial interface. This EEPROM stores a permanently write-protected MAC address in upper half of memory array.

Two status LEDs indicator configured by software. See Table 4-2.

LEDs	Colour	Description
Left LED (LED1)	Green	Speed indicator: Green on – Operating as a 100Mbps connection. Green off – Operating as a 10Mbps connection.
Right LED (LED0)	Yellow	Link/Activity indicator: Blinking – There is activity on this port. Off – No link is established.

Table 4-2 – Ethernet LEDs

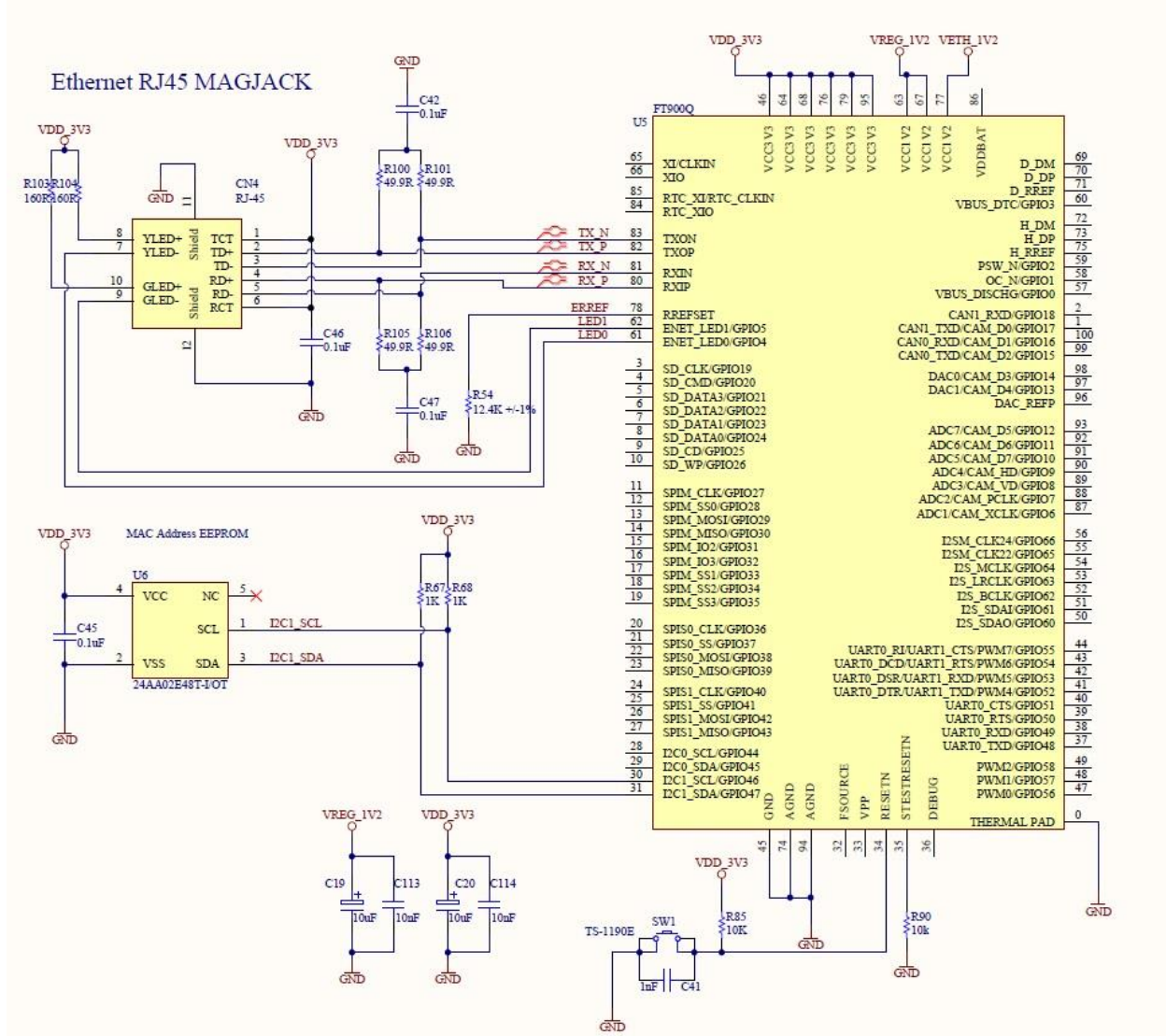

Figure 4-7 – Ethernet connector

4.6 Programmer Interface

The programmer interface **CN7**, 2x5 pins 1.27mm pitch female Micro-Match header supports software application download, GDB debugging and EFUSE program on MM900EVxA development boards with the [UMFTPD2A module](#). For details of the tool operation, please refer to [AN 325 FT900 Tool Chain Installation Guide document](#).

4.6.1 CN7 – 10-pin Micro-Match Program Interface Signals

Pin No.	Name	Type	Description
1	SPIO_SCK	I	SPI Slave 0 clock input
2	SPIO_SS _n	I	SPI Slave 0 chip select, active low

Pin No.	Name	Type	Description
3	SPIO_MOSI	I	SPI Slave 0 data input
4	SPIO_MISO	O	SPI Slave 0 data output
5	VPP	P	EFUSE program power supply. If unused, keep floating.
6	FRSC	P	EFUSE program power supply. If unused, tied to GND through 10Kohm resistor.
7	GND	P	Ground
8	DEBUG	I/O	FT90x One-Wire Interface
9	GDB_5V	P	External 5V power supply Reserved D3 Diode with external power supply.
10	RESETn	P	H/W Reset, active low

Table 4-3 – CN7 Pinout

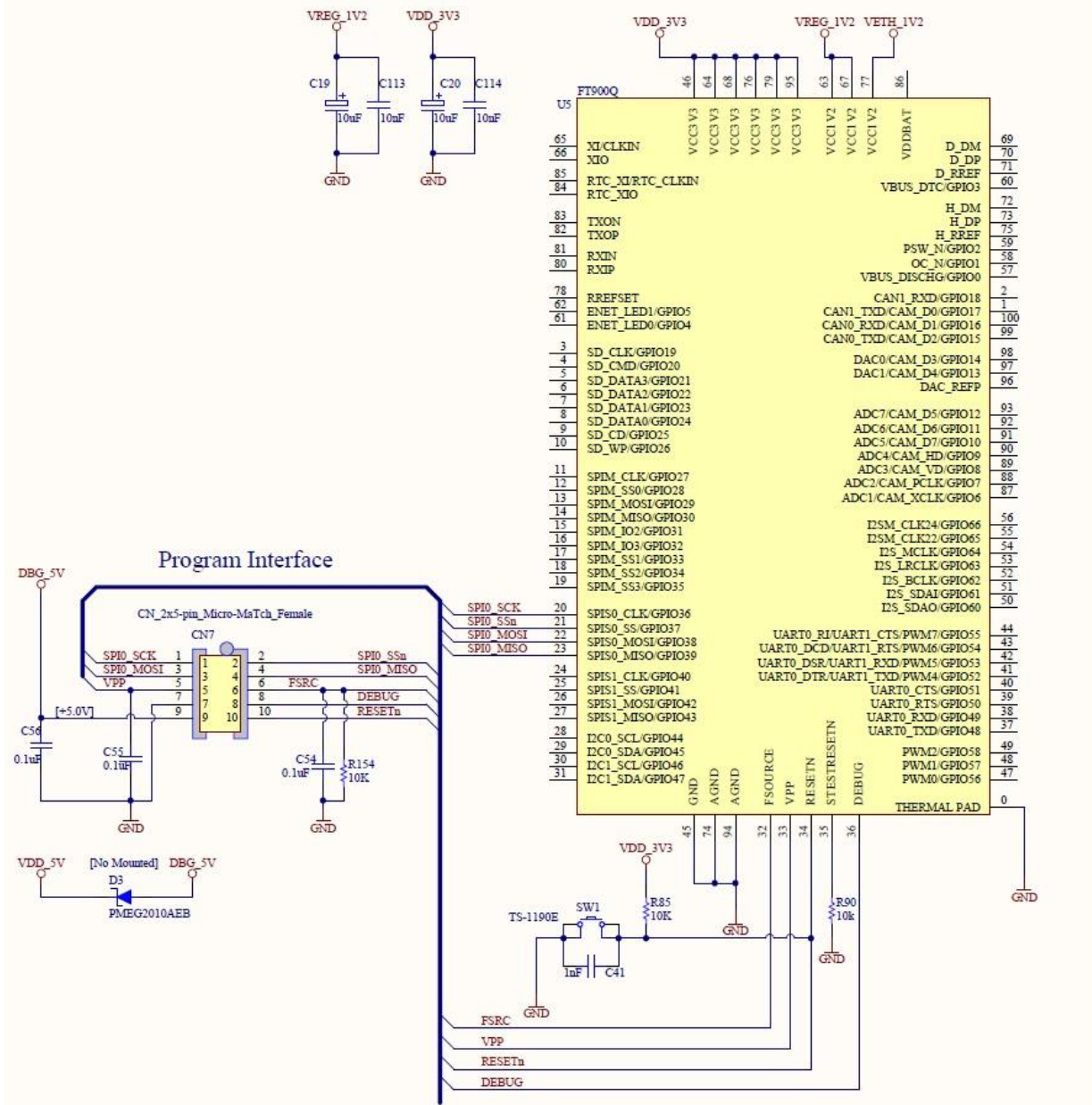

Figure 4-8 – Program Interface

4.7 SPI Master Interface

The FT900 microcontroller has a SPI master interface that supports single, dual and quad SPI data transfer modes. There are two alternative connectors for supporting different LCD display modules as SPI slave devices.

- The **J2** dual-entry 2x8 pins 2.54mm pitch, female header (Table 4-4) is designed for FT80x and FT81x Embedded Video Engine (EVE) family LCD display modules. As an example the [ME810A-HV35R module](#), can connect directly to MM900EVxA development boards on the bottom side with a male pin header.
- The **CN12** 16 pins 0.5mm pitch, bottom contact FFC/FPC connector (Table 4-5) provides an alternative connection for LCD display modules that meet FT80x or FT81x chip technical specifications and use a 16-pin 0.5mm pitch flexible flat cable to link to the board.

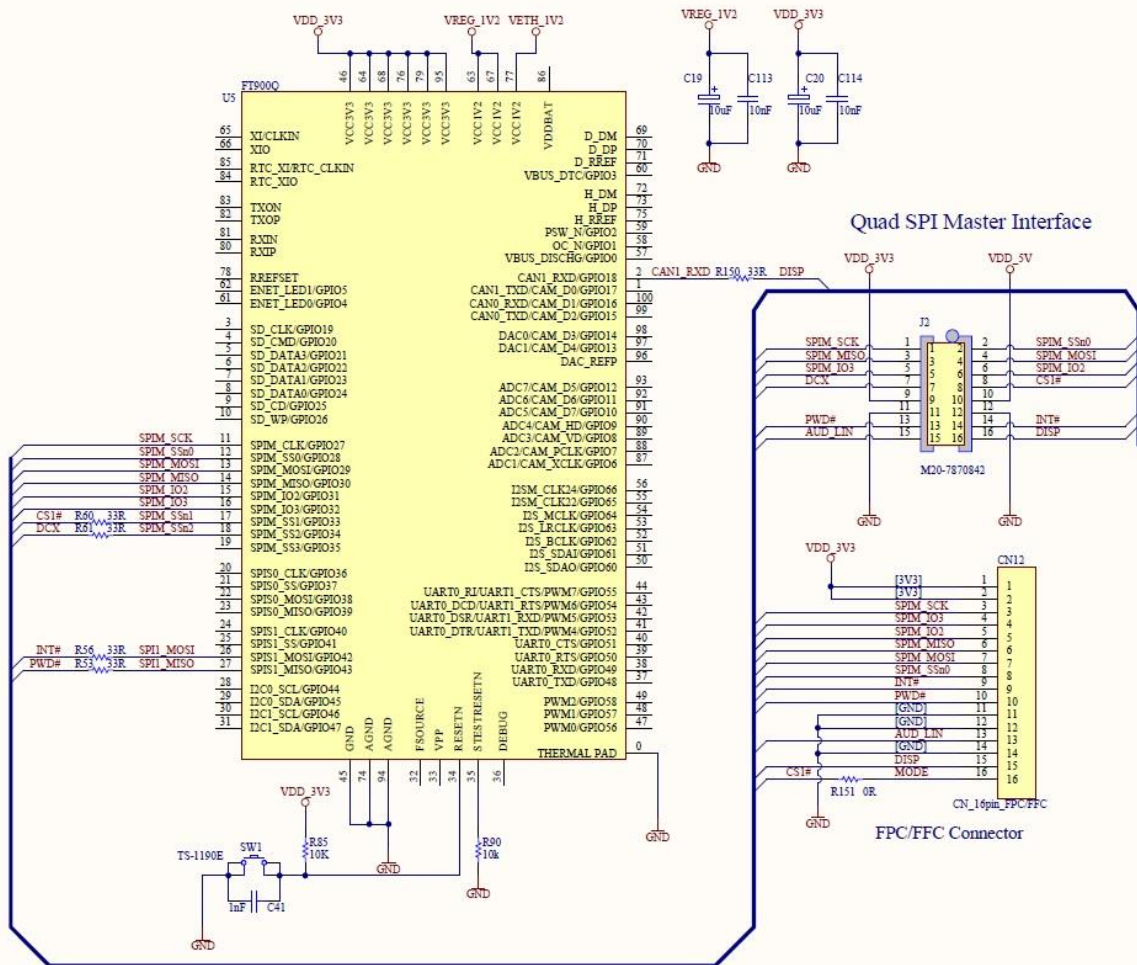

Figure 4-9 – SPI Master Interface

4.7.1 J2 – 16-pin Dual Entry Header, SPI Master and Control Signals

Pin No.	Name	Type	Description
1	SPIM_SCK	O	SPI Master clock output
2	SPIM_SS0	O	SPI Master chip select 0, active low
3	SPIM_MISO	I/O	SPI Master input, Slave output Data 1 for Quad SPI
4	SPIM_MOSI	I/O	SPI Master output, Slave input Data 0 for Quad SPI
5	SPIM_IO3	I/O	General I/O, data 3 for Quad SPI
6	SPIM_IO2	I/O	General I/O, data 2 for Quad SPI
7	DCX	O	Data / command selection pin for LCD controller Low: Command High: Parameter
8	CS1#	O	SPI Master chip select 1, active low for LCD

Pin No.	Name	Type	Description
			controller
9	VDD_3V3	P	3.3V power supply
10	VDD_5V	P	5V power supply
11	GND	P	Ground
12	GND	P	Ground
13	PWD#	O	FT80X power down control, active low
14	INT#	I	Interrupt input from FT80X, active low
15	AUD_LIN	I	Audio PWM input from FT80X
16	DISP	O	LCD display enable

Table 4-4 – J2 Pinout

4.7.2 CN12 – 16-pin FPC/FFC connector

Pin No.	Name	Type	Description
1,2	VDD_3V3	P	3.3V Power supply
3	SPIM_SCK	O	SPI Master clock output
4	SPIM_IO3	I/O	General I/O, data 3 for Quad SPI
5	SPIM_IO2	I/O	General I/O, data 2 for Quad SPI
6	SPIM_MISO	I/O	SPI Master input, Slave output Data 1 for Quad SPI
7	SPIM_MOSI	I/O	SPI Master output, Slave input Data 0 for Quad SPI
8	SPIM_SS0	O	SPI Master chip select 0, active low
9	INT#	I	Interrupt input from FT80X, active low
10	PWD#	O	FT80X power down control, active low
11,12,14	GND	P	Ground
13	AUD_LIN	I	Audio PWM input from FT80X
15	DISP	O	LCD display enable
16	MODE	O	Serial interface selection for FT80X Low: SPI interface High: I2C interface

Table 4-5 – CN12 Pinout

4.8 Audio codec

A Cirrus Logic WM8731 Audio Codec device is included in the MM900EVxA development boards for multimedia functionality. It is a low power stereo codec with an integrated headphone driver, designed specifically for MP3 audio, speech player and recorder applications.

This codec device can provide the following audio performance:

- ADC SNR 90dB ('A' weighted) at 3.3V
- DAC SNR 100dB ('A' weighted) at 3.3V
- ADC and DAC sampling frequency range: 8KHz – 96KHz

The digital audio interface is a 4-line I²S interface which connects to the FT900 microcontroller and audio codec device. Both I²S devices can be registered to interface in master or slave mode. In this design, the FT900 microcontroller I²S interface has to be configured in the slave mode, while the WM8731 device is in master mode and controls the sequence of the data and clocks on the digital audio interface.

4.8.1 Microphone Input

An electret condenser microphone (**P1**) provides an audio input on the MM900EVxA board (Figure 4-10), which gets a bias voltage from the audio codec device. This omnidirectional microphone works at frequencies from 100Hz to 20,000Hz. See Table 4-6 microphone specifications.

SPECIFICATIONS

directivity	omnidirectional	
sensitivity (S)	-44 ±3 dB	f = 1KHz, 1Pa 0dB = 1V/Pa
sensitivity reduction (ΔS-Vs)	-3 dB	f = 1KHz, 1Pa Vs = 2 ~ 1.5 V dc
operating voltage	2 V dc (standard), 10 V dc (max.)	
output impedance (Zout)	2.2 KΩ	f = 1KHz, 1Pa
operating frequency (f)	100 ~ 20,000 Hz	
current consumption (IDSS)	0.5 mA max.	Vs = 2 V dc RL = 2.2KΩ
signal to noise ratio (S/N)	56 dBA	f = 1KHz, 1Pa A-weighted
operating temperature	-20 ~ +70° C	
storage temperature	-20 ~ +70° C	
dimensions	ø6 x 5 mm	
weight	0.30 g max.	
material	Al	
terminal	pin type (Au plating, hand soldering only)	
RoHS	yes	

Table 4-6 – P1 Microphone Specifications

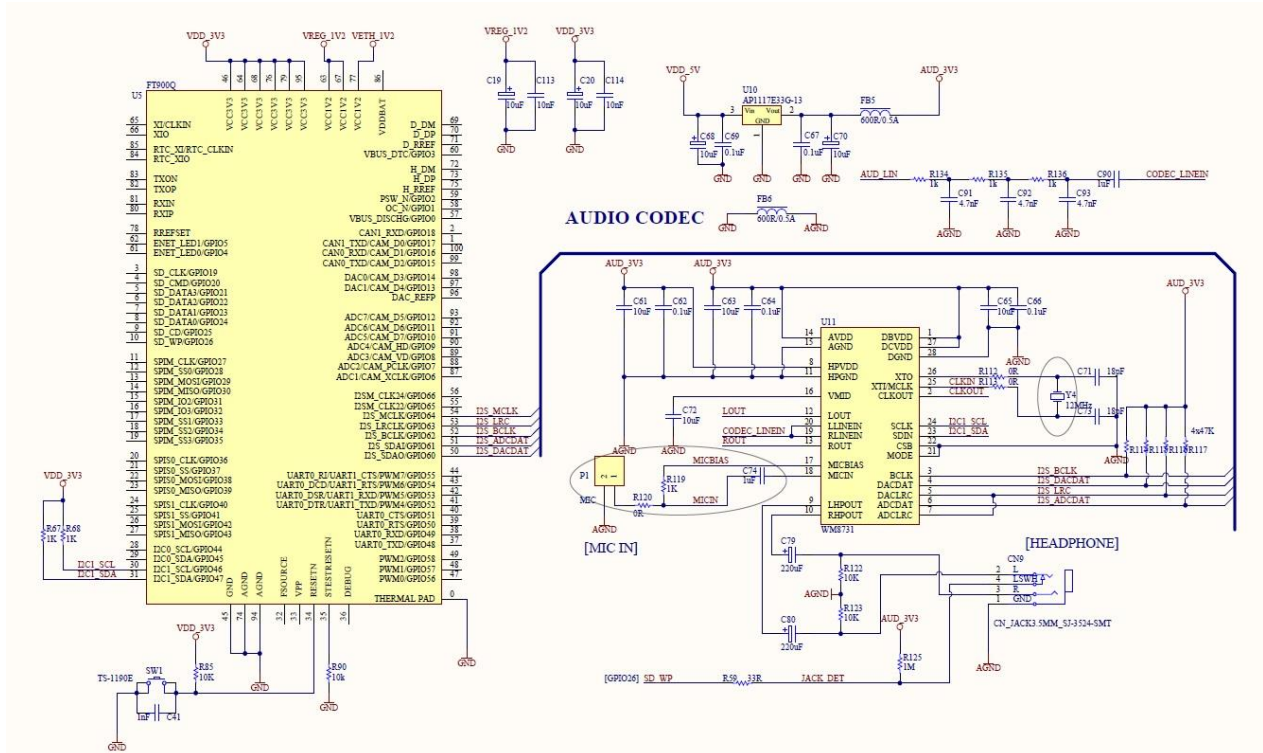

Figure 4-10 – Microphone Input

4.8.2 Audio Output

The Audio Codec also includes two audio inputs which are an I2S digital audio interface and stereo line. The stereo line can connect to external audio input sources (e.g. FT80X or FT81X family Audio PWM audio output).

There are two paths for stereo audio output provided by the audio codec device.

The first stereo audio output option is via headphone:

- **CN9**, a 3.5mm length, 4 contacts headphone jack.

The second option is via two speakers:

- **CN10**, right angle 2-pin header for external speaker connection as Left channel.
- **CN11**, right angel 2-pin header for external speaker connection as Right channel.
- **JP2**, 3-pin jumper controls speakers stereo audio output.

Pin No.	Name
1-2	Speakers On
2-3	Speakers Mute

Table 4-7 – JP2 Pinout

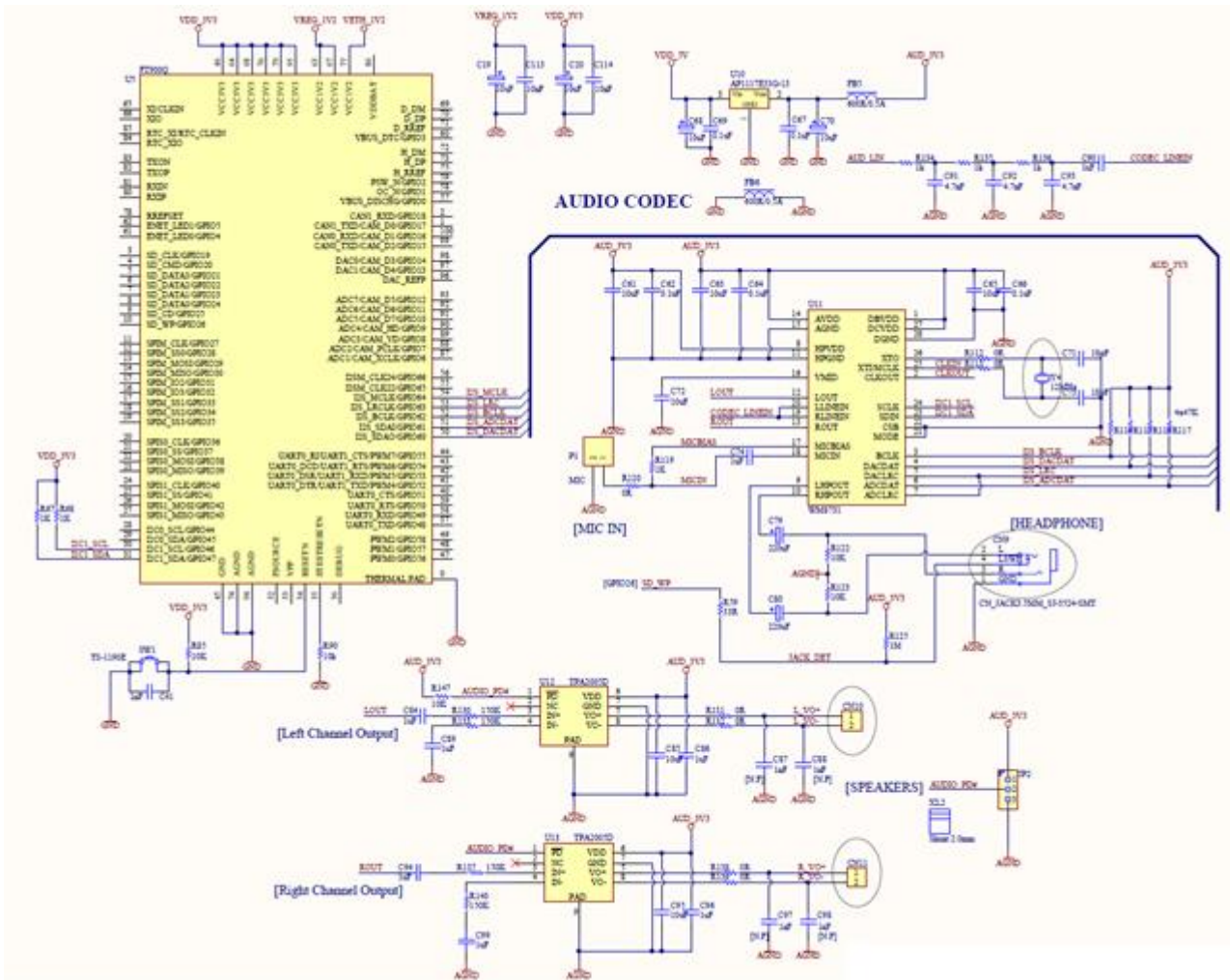

Figure 4-11 – Audio Output

4.9 Camera connector

The MM900EV2A/3A development boards have an Omni vision OV9655 camera module mounted either on the top (-EV2A) or the bottom (-EV3A) via a 24-pin 0.5mm pitching FFC/FPC, bottom contact connector on the board. See Table 4-8 camera connector pinout.

Pin No.	Name	Description
1	-	Reserved
2	GND	Ground
3	I2C0_SDA	I2C serial bus, data line
4	CAM_2V5	2.5V power supply
5	I2C0_SCL	I2C serial bus, clock line
6	RESETn	Hardware reset, active low
7	CAM_VD	Camera vertical sync input
8	CAM_PWDN	Camera module power down signal, active high
9	CAM_HD	Camera horizontal reference input
10	CAM_1V8	1.8V power supply

Pin No.	Name	Description
11	CAM_3V3	3.3V power supply
12	CAM_D7	Camera data line, Bit 7
13	CAM_XCLK	Camera external clock output
14	CAM_D6	Camera data line, Bit 6
15	GND	Ground
16	CAM_D5	Camera data line, Bit 5
17	CAM_PCLK	Camera pixel clock input
18	CAM_D4	Camera data line, Bit 4
19	CAM_D0	Camera data line, Bit 0
20	CAM_D3	Camera data line, Bit 3
21	CAM_D1	Camera data line, Bit 1
22	CAM_D2	Camera data line, Bit 2
23	Y1	Reserved
24	Y2	Reserved

Table 4-8 – Camera Connector Pinout

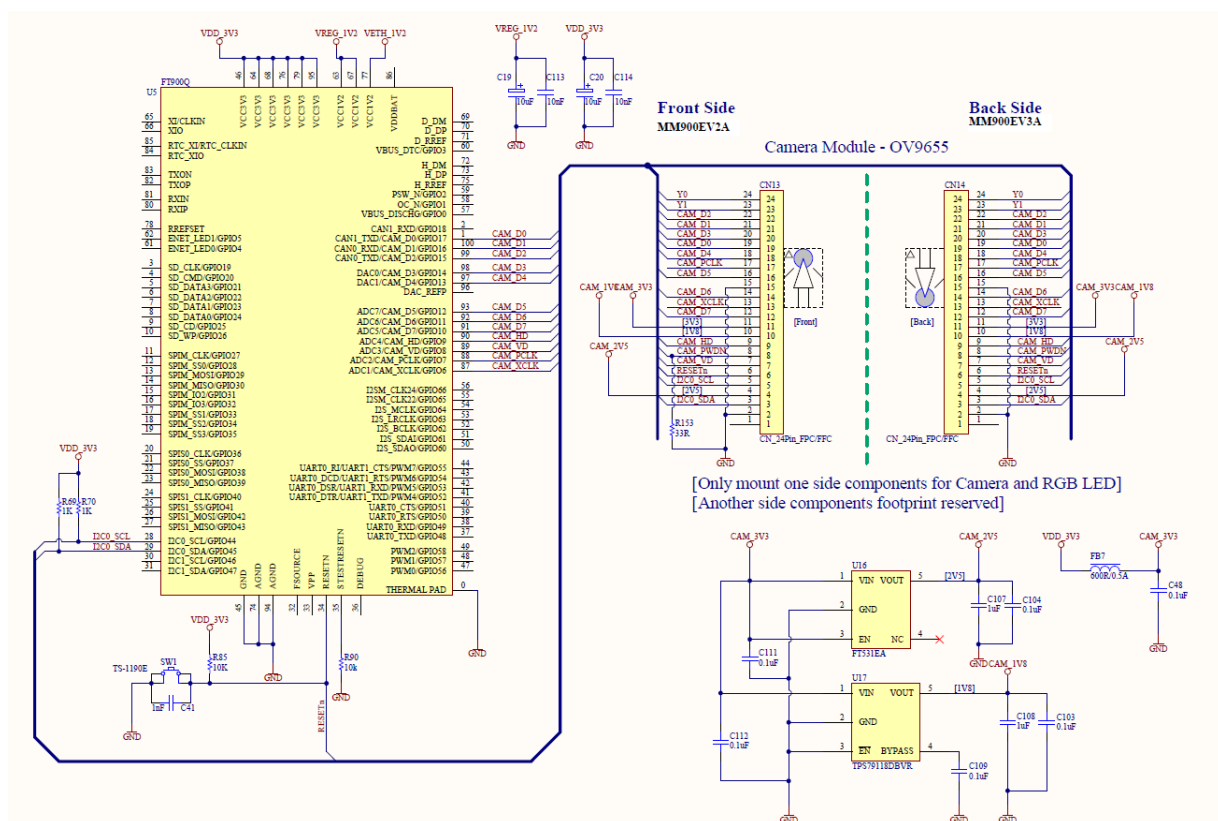

Figure 4-12 – Camera connector

4.10 RGB LEDs

There are two configurable RGB LED indicators on the MM900EV2A/3A development modules. GPIO41 toggles the RGB chip data input and transfers the composition of 24bit data onwards.

Composition of 24bit data:

G7	G6	G5	G4	G3	G2	G1	G0	R7	R6	R5	R4	R3	R2	R1	R0	B7	B6	B5	B4	B3	B2	B1	B0
----	----	----	----	----	----	----	----	----	----	----	----	----	----	----	----	----	----	----	----	----	----	----	----

Note: Follow the order of GRB to send data and the high bit sent at first.

Table 4-9 – RGB LED 24-bit data order

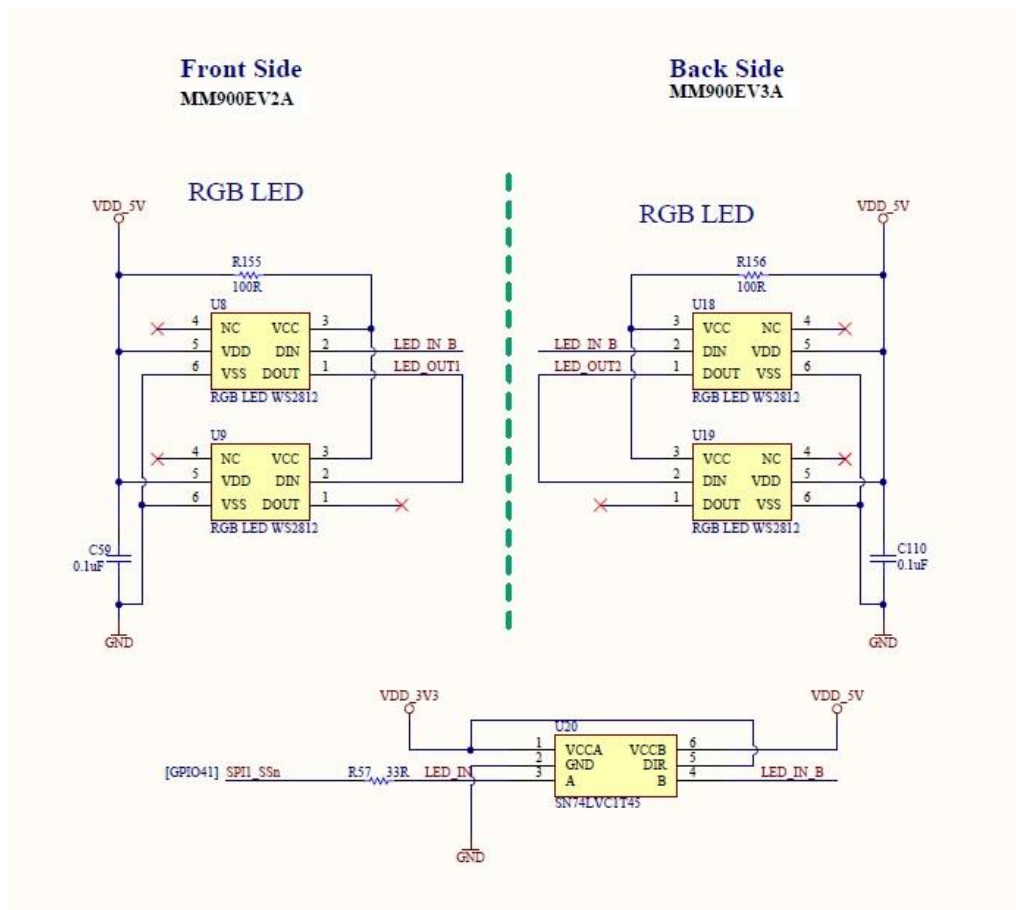

Figure 4-13 – RGB LEDs

4.11 RTC

The MM900EVxA development modules provide a 32.768 KHz quartz crystal and load capacitors for an external Real Time Clock (RTC). See Figure 4-14, the two circled zero ohm resistors (**R141**, **R142**) are alternatives for the FT900 microcontroller RTC. By default, those resistors are not populated.

The external Microchip RTC device operating voltage is between 1.8V and 5.5V, with typical current at a very low 1.2uA at 3.3V. It uses a high quality coin cell with 0.2F capacitor as an auxiliary power source on board. With powering on/off the development module, the capacitor will be charging / discharging.

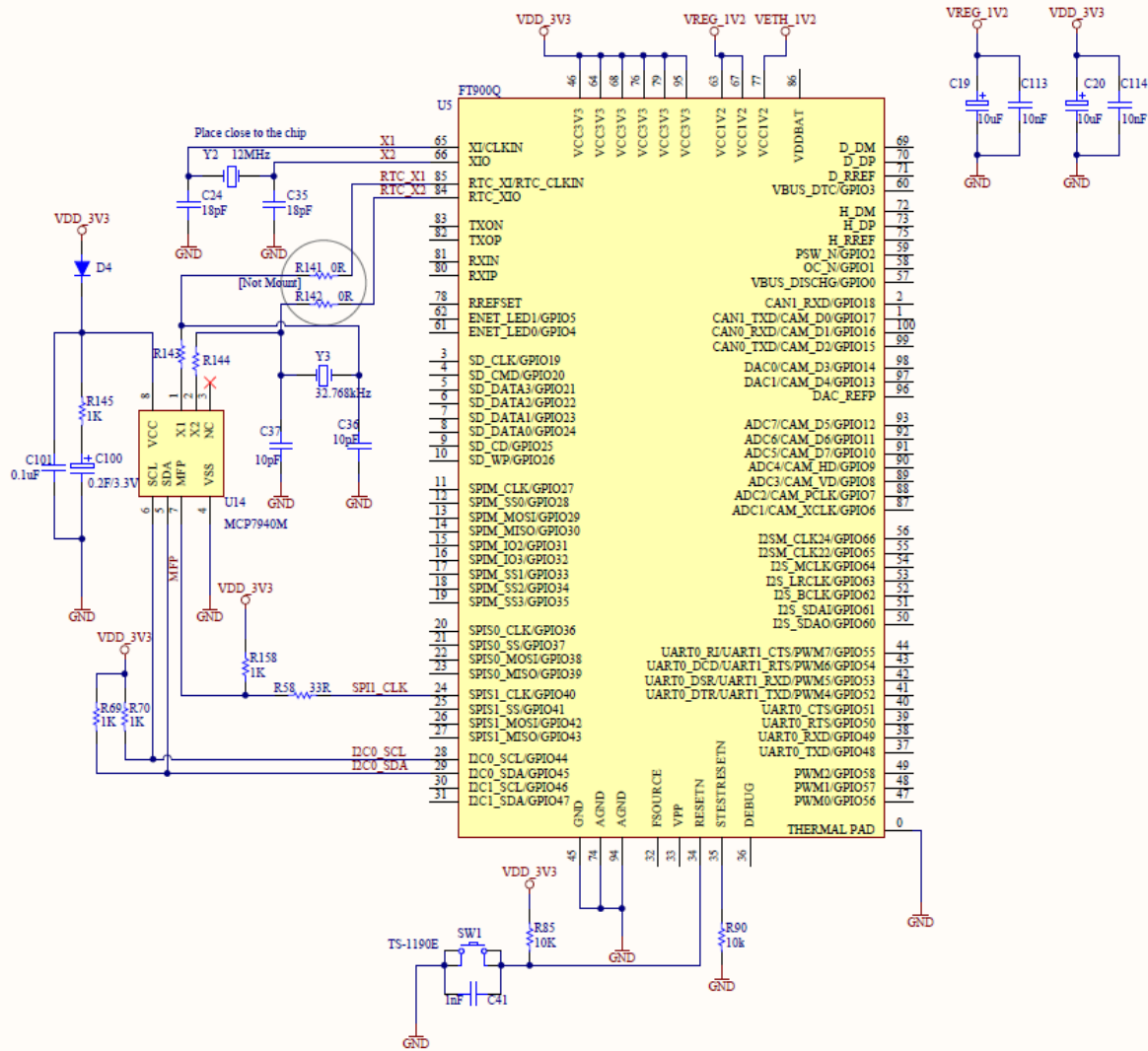

Figure 4-14 - RTC

4.12 External I/O Bus

There are 32 multiple function GPIOs provided on **CN3** 2x20 pins, 0.5mm pitch female header. External feature boards may connect via UART, PWM, ADC, DAC, SPI, I²C and Camera interfaces on this IO connector.

Table 4-10 lists all features assigned for each GPIO pin.

Pin No.	Function 1	Function 2	Function 3	Function 4
1,2,15,24	GND	-	-	-
3	GPIO54	UART0_DCD	UART1_RTS	PWM6
4	GPIO48	UART0_TXD	-	-
5	NC	-	-	-
6	GPIO49	UART0_RXD	-	-
7	GPIO53	UART0_DSR	UART1_RXD	PWM5

Pin No.	Function 1	Function 2	Function 3	Function 4
8	GPIO50	UART0_RTS	-	-
9	GPIO52	UART0_DTR	UART1_TXD	PWM4
10	GPIO51	UART0_CTS	-	-
11	GPIO55	UART0_RI	UART1_CTS	PWM7
12	GPIO58	-	-	PWM2
13	GPIO56	-	-	PWM0
14	GPIO57	-	-	PWM1
16	5V	-	-	-
17	GPIO35	SPIM_SS3	-	-
18	GPIO27	SPIM_CLK	-	-
19	GPIO30	SPIM_MISO	-	-
20	GPIO29	SPIM_MOSI	-	-
21	GPIO32	SPIM_IO3	-	-
22	GPIO31	SPIM_IO2	-	-
23	3V3	-	-	-
25	GPIO46	I2C1_SCL	-	-
26	GPIO47	I2C1_SDA	-	-
27	GPIO08	CAM_VD	ADC3	-
28	GPIO09	CAM_HD	ADC4	-
29	GPIO07	CAM_PCLK	ADC2	-
30	GPIO06	CAM_XCLK	ADC1	-
31	GPIO10	CAM_D7	ADC5	-
32	GPIO11	CAM_D6	ADC6	-
33	GPIO12	CAM_D5	ADC7	-
34	GPIO13	CAM_D4	DAC1	-
35	GPIO14	CAM_D3	DAC0	-
36	GPIO15	CAM_D2	CAN0_TXD	-
37	GPIO16	CAM_D1	CAN0_RXD	-
38	GPIO17	CAM_D0	CAN1_TXD	-
39	RESETn	-	-	-
40	GPIO18	-	CAN1_RXD	-

Table 4-10 – External I/O Bus

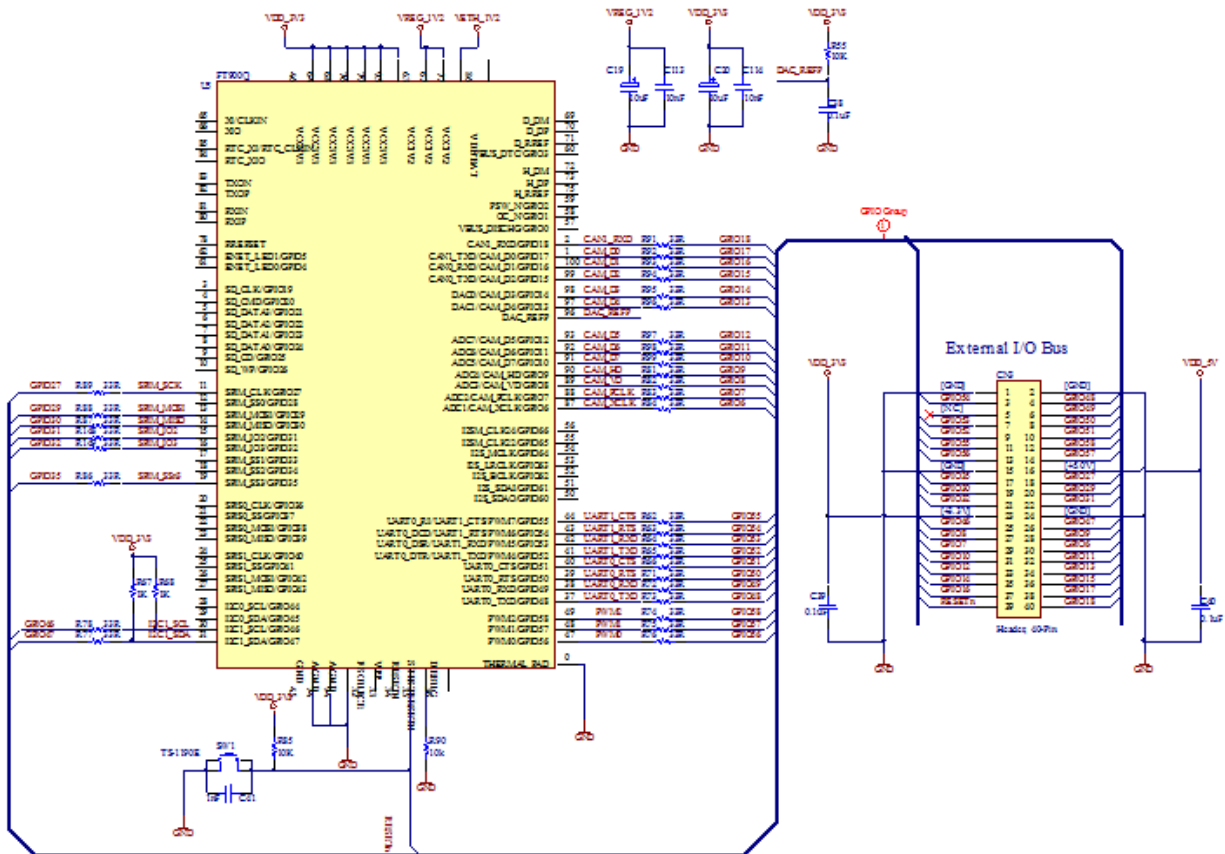

Figure 4-15 – External I/O Bus

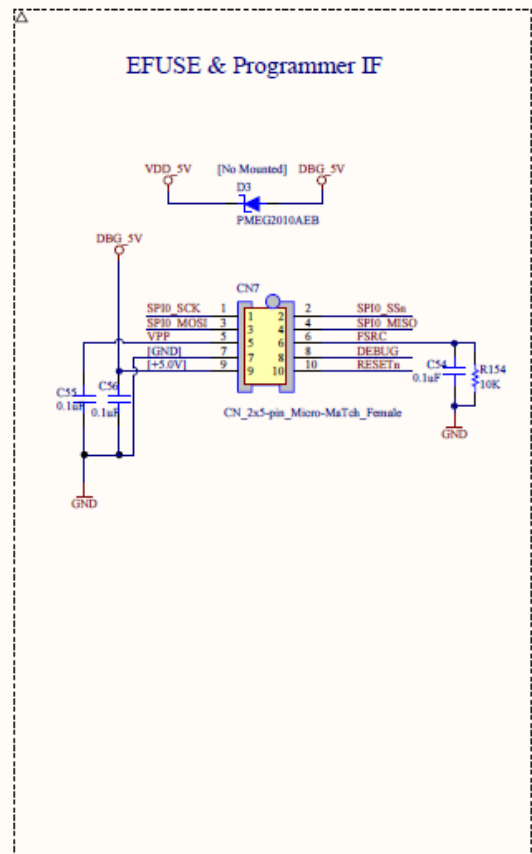
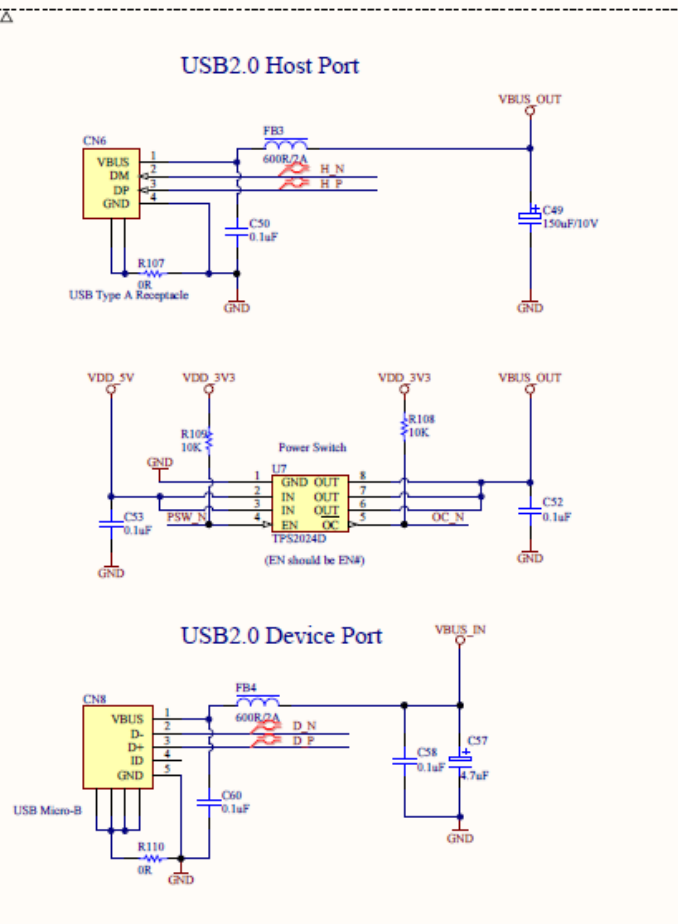
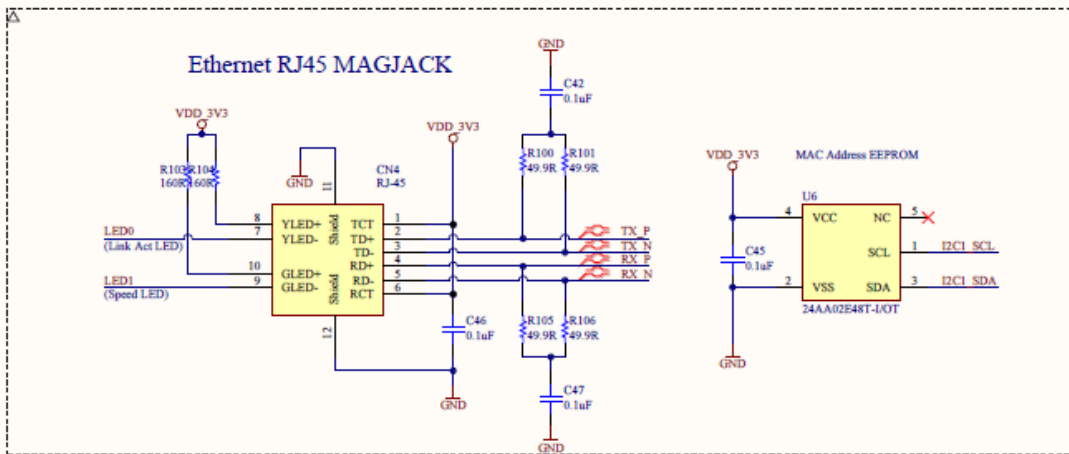

Figure 5-3 – Sheet 2-FT900 Interfaces and Connectors(1)

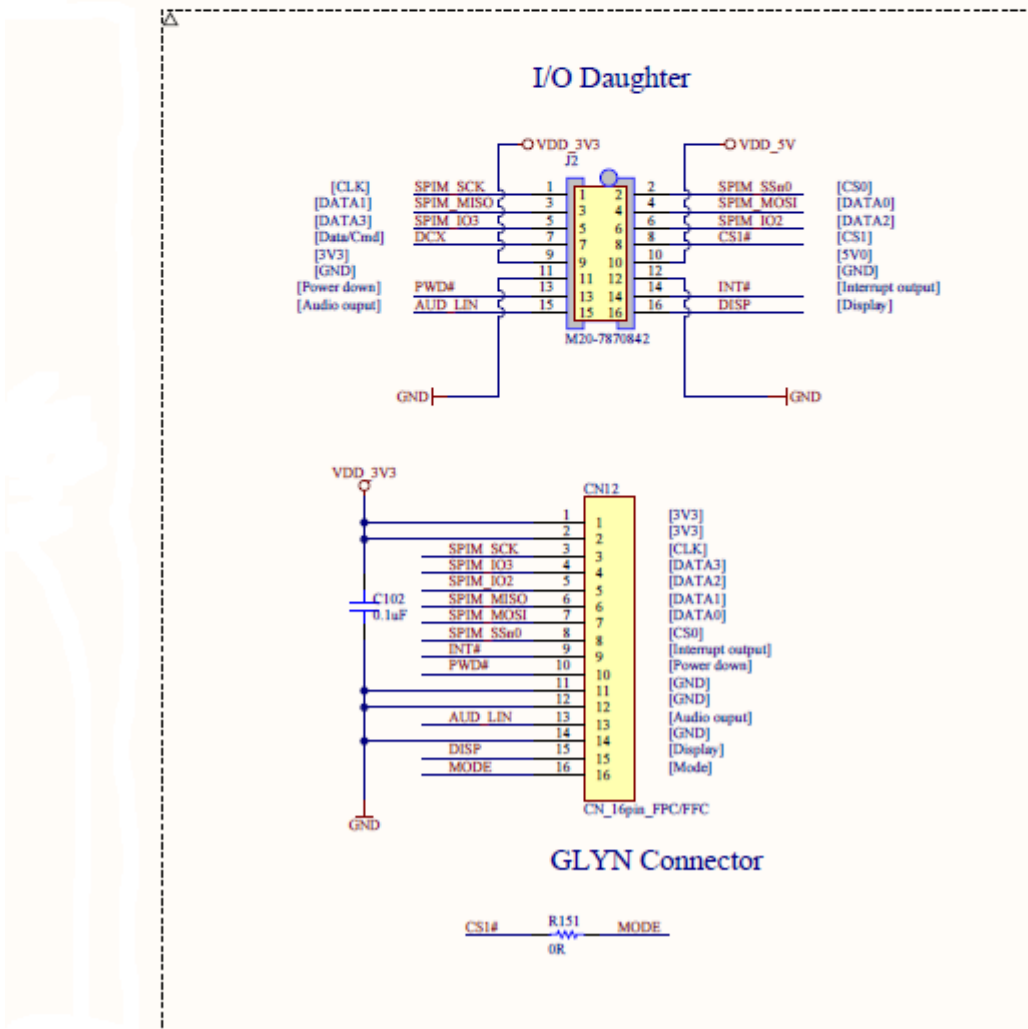
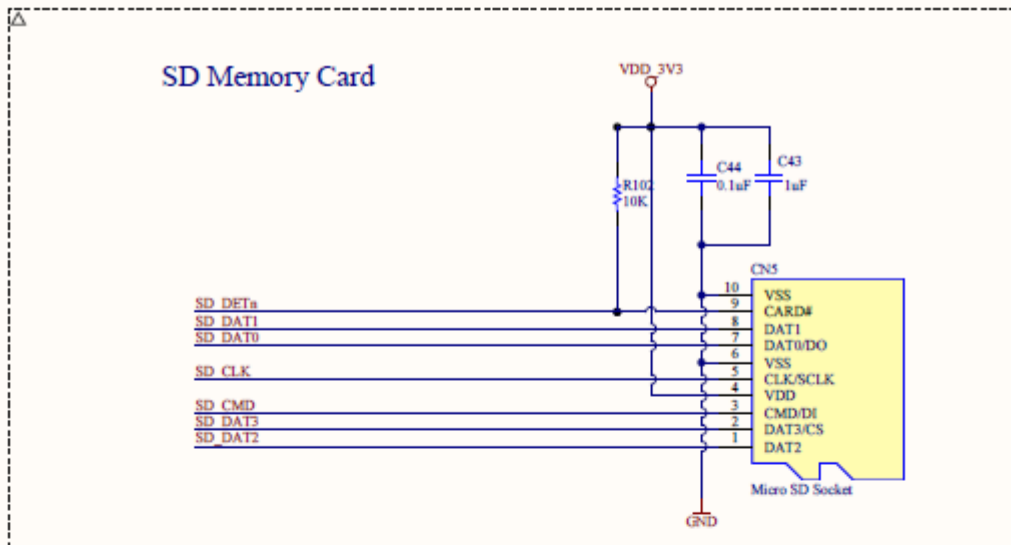

Figure 5-4 – Sheet 2-FT900 Interfaces and Connectors(1)

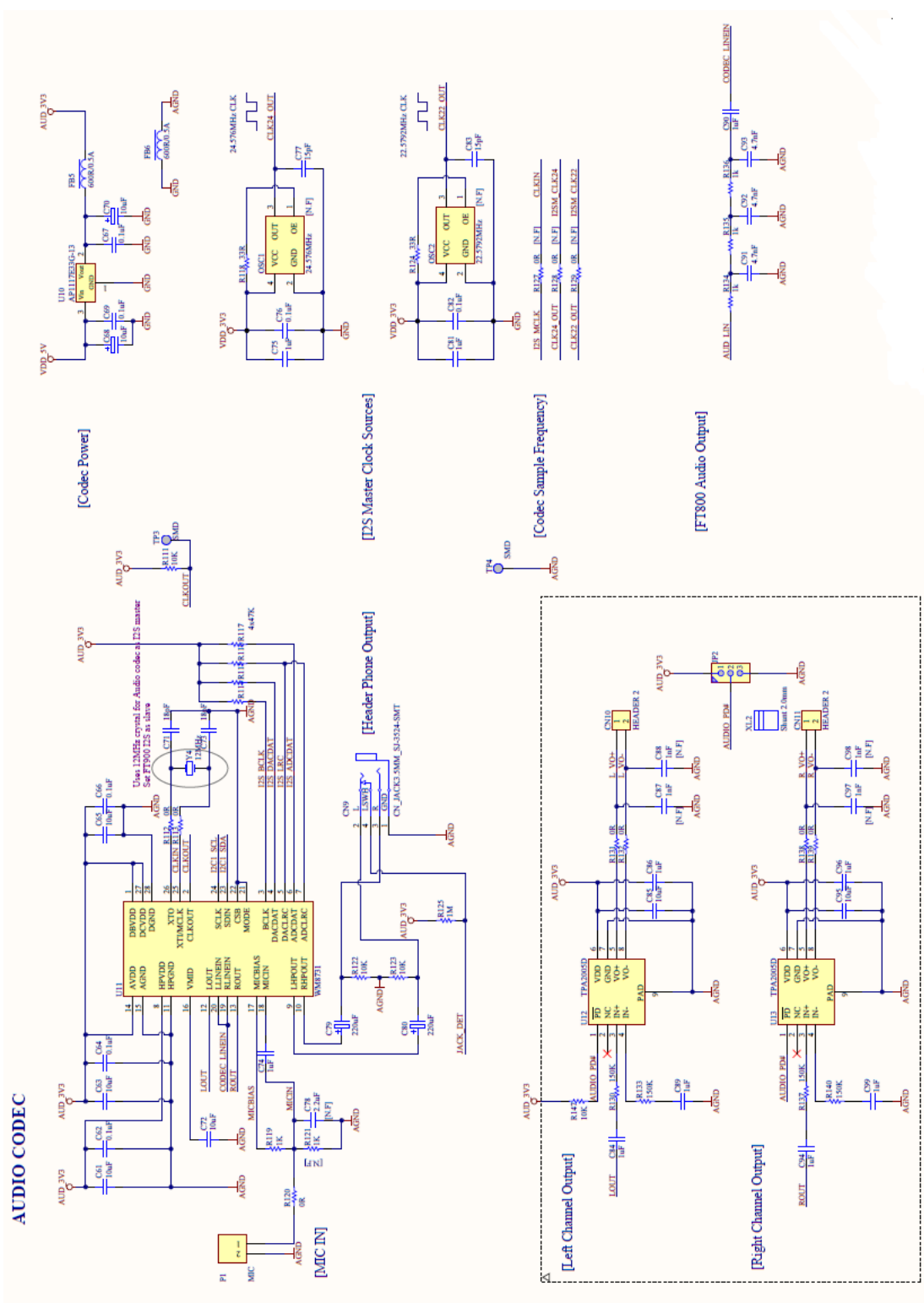

Figure 5-5 – Sheet 3-FT900 Audio Codec

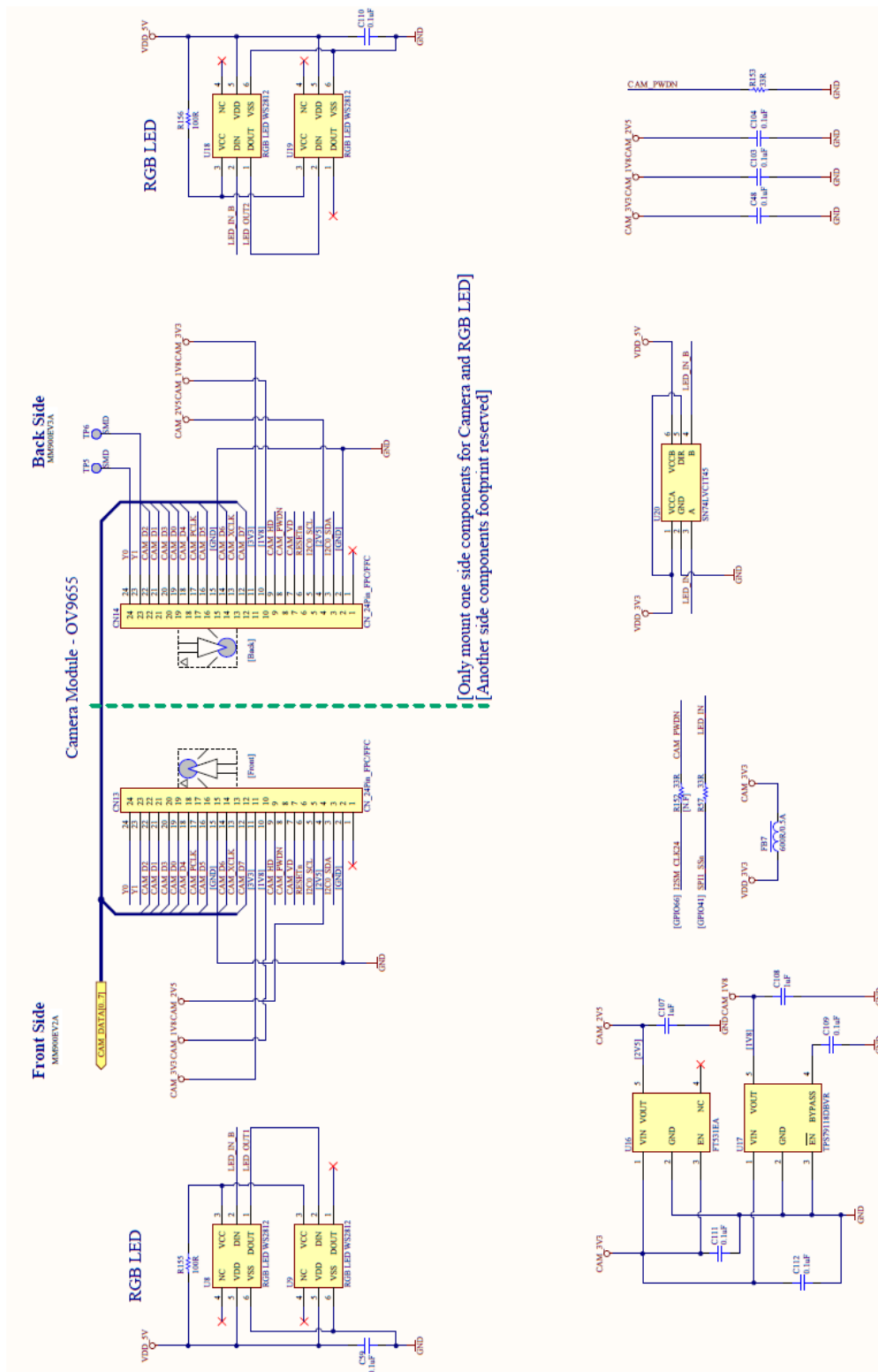

Figure 5-6 – Sheet 4-FT900 Camera Interface

7 Contact Information

Head Office – Glasgow, UK

Unit 1, 2 Seaward Place, Centurion Business Park
Glasgow G411HH
United Kingdom
Tel: +44 (0) 141 429 2777
Fax: +44 (0) 141 429 2758

E-mail (Sales) sales1@ftdichip.com
E-mail (Support) support1@ftdichip.com
E-mail (General Enquiries) admin1@ftdichip.com

Branch Office – Tigard, Oregon, USA

7130 SW Fir Loop
Tigard, OR 97223
USA
Tel: +1 (503) 547 0988
Fax: +1 (503) 547 0987

E-Mail (Sales) us.sales@ftdichip.com
E-Mail (Support) us.support@ftdichip.com
E-Mail (General Enquiries) us.admin@ftdichip.com

Branch Office – Taipei, Taiwan

2F, No. 516, Sec. 1, NeiHu Road
Taipei 114
Taiwan, R.O.C.
Tel: +886 (0) 2 8797 1330
Fax: +886 (0) 2 8751 9737

E-mail (Sales) tw.sales1@ftdichip.com
E-mail (Support) tw.support1@ftdichip.com
E-mail (General Enquiries) tw.admin1@ftdichip.com

Branch Office – Shanghai, China

Room 1103, No. 666 West Huaihai Road,
Shanghai, 200052
China
Tel: +86 (0)21 6235 1596
Fax: +86 (0)21 6235 1595

E-mail (Sales) cn.sales@ftdichip.com
E-mail (Support) cn.support@ftdichip.com
E-mail (General Enquiries) cn.admin@ftdichip.com

Web Site

<http://ftdichip.com>

Distributor and Sales Representatives

Please visit the Sales Network page of the [FTDI Web site](#) for the contact details of our distributor(s) and sales representative(s) in your country.

System and equipment manufacturers and designers are responsible to ensure that their systems, and any Future Technology Devices International Ltd (FTDI) devices incorporated in their systems, meet all applicable safety, regulatory and system-level performance requirements. All application-related information in this document (including application descriptions, suggested FTDI devices and other materials) is provided for reference only. While FTDI has taken care to assure it is accurate, this information is subject to customer confirmation, and FTDI disclaims all liability for system designs and for any applications assistance provided by FTDI. Use of FTDI devices in life support and/or safety applications is entirely at the user's risk, and the user agrees to defend, indemnify and hold harmless FTDI from any and all damages, claims, suits or expense resulting from such use. This document is subject to change without notice. No freedom to use patents or other intellectual property rights is implied by the publication of this document. Neither the whole nor any part of the information contained in, or the product described in this document, may be adapted or reproduced in any material or electronic form without the prior written consent of the copyright holder. Future Technology Devices International Ltd, Unit 1, 2 Seaward Place, Centurion Business Park, Glasgow G4 1 1HH, United Kingdom. Scotland Registered Company Number: SC136640

Appendix A - References

Document References

FT90X webpage: <http://www.ftdichip.com/Products/ICs/FT90x.html>

FT90X datasheet: [FT900/FT901/FT902/FT903 Datasheet](#)

FT900 tool chain installation guide document: [AN 325 FT900 Tool Chain Installation Guide](#)

FT90X system registers: [AN 324 FT900 User Manual](#)

FT90x Peripheral Driver Library: [AN 365 FT900 API Programmers Manual](#)

FT90x Example Applications: [AN 360 FT90x Example Applications](#)

UMFTPD2A program module datasheet: [DS UMFTPD2A](#)

ME800A-HV35R LCD display module document: [DS ME810A HV35R](#)

Acronyms and Abbreviations

Terms	Description
ADC	Analog to Digital Converter
DAC	Digital to Analog Converter
EVE	Embedded Video Engine
FFC	Flexible Flat Cable
FPC	Flexible Printed Circuit
I/O	Input / Output
I2C	Inter Integrated Circuit
I2S	Integrated Interchip Sound
IEEE	The Institute of Electrical and Electronics Engineers
LCD	Liquid Crystal Display
LDO	Low Drop Out regulator
LED	Light-emitting diode
PCB	Printed Circuit Board
PWM	
QFN	Quad Flat No Leads
RGB	Red Green Blue (color model)
RTC	Real Time Clock

SPI	Serial Peripheral Interface
UHS	Ultra High Speed
USB	Universal Serial Bus
UART	Universal Asynchronous Receiver/Transmitter

Appendix B - List of Figures and Tables

List of Figures

Figure 4-1 – MM900EV1A Board Layout	6
Figure 4-2 – MM900EV2A/3A Board Layout.....	7
Figure 4-3 – Power supply	8
Figure 4-4 – FT900 Microcontroller	8
Figure 4-5 – Micro SD Connector	9
Figure 4-6 – USB Connectors.....	10
Figure 4-7 – Ethernet connector	12
Figure 4-8 – Program Interface.....	14
Figure 4-9 – SPI Master Interface.....	15
Figure 4-10 – Microphone Input.....	18
Figure 4-11 – Audio Output	19
Figure 4-12 – Camera connector.....	20
Figure 4-13 – RGB LEDs	21
Figure 4-14 – RTC.....	22
Figure 4-15 – External I/O Bus	24
Figure 5-1 – Sheet 1-FT900 MCU(1)	25
Figure 5-2 – Sheet 1-FT900 MCU(2)	26
Figure 5-3 – Sheet 2-FT900 Interfaces and Connectors(1)	27
Figure 5-4 – Sheet 2-FT900 Interfaces and Connectors(1)	28
Figure 5-5 – Sheet 3-FT900 Audio Codec.....	29
Figure 5-6 – Sheet 4-FT900 Camera Interface	30
Figure 6-1 – MM900EV1A PCB Dimensions	31
Figure 6-2 – MM900EV2A/3A PCB Dimensions	32

List of Tables

Table 2-1 – Ordering information.....	2
Table 4-1 – JP3 Pinout.....	7
Table 4-2 – Ethernet LEDs.....	11
Table 4-3 – CN7 Pinout	13
Table 4-4 – J2 Pinout	16
Table 4-5 – CN12 Pinout.....	16
Table 4-6 – P1 Microphone Specifications	17
Table 4-7 – JP2 Pinout.....	18
Table 4-8 – Camera Connector Pinout.....	20
Table 4-9 – RGB LED 24-bit data order.....	21

Table 4-10 – External I/O Bus	23
-------------------------------------	----

Appendix C – Revision History

Document Title : MM900EVxA Development Board Datasheet
Document Reference No. : FT_001189
Clearance No. : FTDI# 469
Product Page : <http://www.ftdichip.com/Products/ICs/FT90x.html>
Document Feedback : [Send Feedback](#)

Revision	Changes	Date
1.0	Initial Release	2015-09-29
1.1	Update to section 5 schematic to allow text to be visible	2015-09-30
1.2	Updated Figure 4 11 – Audio Output	2016-04-07