

# MC68HC908GR8 MC68HC908GR4

Data Sheet

***M68HC08***  
***Microcontrollers***

MC68HC908GR8  
Rev. 7  
10/2006

[freescale.com](http://freescale.com)







# **MC68HC908GR8**

# **MC68HC908GR4**

## **Data Sheet**

---

To provide the most up-to-date information, the revision of our documents on the World Wide Web will be the most current. Your printed copy may be an earlier revision. To verify you have the latest information available, refer to:

<http://freescale.com/>

Freescale™ and the Freescale logo are trademarks of Freescale Semiconductor, Inc.  
This product incorporates SuperFlash® technology licensed from SST.

© Freescale Semiconductor, Inc., 2006. All rights reserved.



# List of Chapters

Chapter 1 General Description	19
Chapter 2 Memory Map	27
Chapter 3 Low-Power Modes	37
Chapter 4 Resets and Interrupts	43
Chapter 5 Analog-to-Digital Converter (ADC)	55
Chapter 6 Break Module (BRK)	63
Chapter 7 Clock Generator Module (CGMC)	69
Chapter 8 Configuration Register (CONFIG)	89
Chapter 9 Computer Operating Properly (COP)	93
Chapter 10 Central Processing Unit (CPU)	97
Chapter 11 Flash Memory	109
Chapter 12 External Interrupt (IRQ)	117
Chapter 13 Keyboard Interrupt (KBI)	121
Chapter 14 Low-Voltage Inhibit (LVI)	127
Chapter 15 Monitor ROM (MON)	131
Chapter 16 Input/Output Ports (I/O)	143
Chapter 17 Random-Access Memory (RAM)	159
Chapter 18 Serial Communications Interface (SCI)	161
Chapter 19 System Integration Module (SIM)	187
Chapter 20 Serial Peripheral Interface (SPI)	205
Chapter 21 Timebase Module (TBM)	225
Chapter 22 Timer Interface Module (TIM)	229
Chapter 23 Electrical Specifications	247
Chapter 24 Mechanical Specifications	269
Chapter 25 Ordering Information	281



# Table of Contents

## Chapter 1 General Description

1.1	Introduction	19
1.2	Features	19
1.2.1	Standard Features of the MC68HC908GR8	19
1.2.2	Features of the CPU08	20
1.3	MCU Block Diagram	21
1.4	Pin Assignments	22
1.5	Pin Functions	24
1.5.1	Power Supply Pins ( $V_{DD}$ and $V_{SS}$ )	24
1.5.2	Oscillator Pins (OSC1 and OSC2)	24
1.5.3	External Reset Pin ( $\overline{RST}$ )	24
1.5.4	External Interrupt Pin ( $\overline{IRQ}$ )	24
1.5.5	CGM Power Supply Pins ( $V_{DDA}$ and $V_{SSA}$ )	24
1.5.6	External Filter Capacitor Pin (CGMXFC)	25
1.5.7	Analog Power Supply/Reference Pins ( $V_{DDAD}/V_{REFH}$ and $V_{SSAD}/V_{REFL}$ )	25
1.5.8	Port A Input/Output (I/O) Pins (PTA3/KBD3–PTA0/KBD0)	25
1.5.9	Port B I/O Pins (PTB5/AD5–PTB0/AD0)	25
1.5.10	Port C I/O Pins (PTC1–PTC0)	25
1.5.11	Port D I/O Pins (PTD6/T2CH0–PTD0/ $\overline{SS}$ )	25
1.5.12	Port E I/O Pins (PTE1/RxD–PTE0/TxD)	26

## Chapter 2 Memory Map

2.1	Introduction	27
2.2	Unimplemented Memory Locations	27
2.3	Reserved Memory Locations	27
2.4	Input/Output (I/O) Section	27
2.5	Memory Map	28
2.6	Register Summary	29
2.7	Vector Addresses	36

## Chapter 3 Low-Power Modes

3.1	Introduction	37
3.1.1	Wait Mode	37
3.1.2	Stop Mode	37
3.2	Analog-to-Digital Converter (ADC)	37
3.2.1	Wait Mode	37
3.2.2	Stop Mode	37

## Table of Contents

3.3	Break Module (BRK)	38
3.3.1	Wait Mode	38
3.3.2	Stop Mode	38
3.4	Central Processor Unit (CPU)	38
3.4.1	Wait Mode	38
3.4.2	Stop Mode	38
3.5	Clock Generator Module (CGM)	38
3.5.1	Wait Mode	38
3.5.2	Stop Mode	38
3.6	Computer Operating Properly Module (COP)	39
3.6.1	Wait Mode	39
3.6.2	Stop Mode	39
3.7	External Interrupt Module (IRQ)	39
3.7.1	Wait Mode	39
3.7.2	Stop Mode	39
3.8	Keyboard Interrupt Module (KBI)	39
3.8.1	Wait Mode	39
3.8.2	Stop Mode	39
3.9	Low-Voltage Inhibit Module (LVI)	39
3.9.1	Wait Mode	39
3.9.2	Stop Mode	40
3.10	Serial Communications Interface Module (SCI)	40
3.10.1	Wait Mode	40
3.10.2	Stop Mode	40
3.11	Serial Peripheral Interface Module (SPI)	40
3.11.1	Wait Mode	40
3.11.2	Stop Mode	40
3.12	Timer Interface Module (TIM1 and TIM2)	40
3.12.1	Wait Mode	40
3.12.2	Stop Mode	41
3.13	Timebase Module (TBM)	41
3.13.1	Wait Mode	41
3.13.2	Stop Mode	41
3.14	Exiting Stop Mode	41

## Chapter 4 Resets and Interrupts

4.1	Introduction	43
4.2	Resets	43
4.2.1	Effects	43
4.2.2	External Reset	43
4.2.3	Internal Reset	43
4.2.3.1	Power-On Reset	44
4.2.3.2	COP Reset	44
4.2.3.3	Low-Voltage Inhibit Reset	45
4.2.3.4	Illegal Opcode Reset	45
4.2.3.5	Illegal Address Reset	45
4.2.4	SIM Reset Status Register	45



4.3	Interrupts	46
4.3.1	Effects	47
4.3.2	Sources	49
4.3.2.1	SWI Instruction	50
4.3.2.2	Break Interrupt	51
4.3.2.3	$\overline{\text{IRQ}}$ Pin	51
4.3.2.4	CGM (Clock Generator Module)	51
4.3.2.5	TIM1 (Timer Interface Module 1)	51
4.3.2.6	TIM2 (Timer Interface Module 2)	51
4.3.2.7	SPI (Serial Peripheral Interface)	51
4.3.2.8	SCI (Serial Communications Interface)	52
4.3.2.9	$\overline{\text{KBD0}}\text{--}\overline{\text{KBD4}}$ Pins	53
4.3.2.10	ADC (Analog-to-Digital Converter)	53
4.3.2.11	TBM (Timebase Module)	53
4.3.3	Interrupt Status Registers	53
4.3.3.1	Interrupt Status Register 1	54
4.3.3.2	Interrupt Status Register 2	54
4.3.3.3	Interrupt Status Register 3	54

## Chapter 5 Analog-to-Digital Converter (ADC)

5.1	Introduction	55
5.2	Features	55
5.3	Functional Description	55
5.3.1	ADC Port I/O Pins	55
5.3.2	Voltage Conversion	56
5.3.3	Conversion Time	56
5.3.4	Conversion	57
5.3.5	Accuracy and Precision	57
5.4	Interrupts	57
5.5	Low-Power Modes	57
5.5.1	Wait Mode	57
5.5.2	Stop Mode	57
5.6	I/O Signals	58
5.6.1	ADC Analog Power Pin ( $V_{\text{DDAD}}$ )/ADC Voltage Reference High Pin ( $V_{\text{REFH}}$ )	58
5.6.2	ADC Analog Ground Pin ( $V_{\text{SSAD}}$ )/ADC Voltage Reference Low Pin ( $V_{\text{REFL}}$ )	58
5.6.3	ADC Voltage In ( $V_{\text{ADIN}}$ )	58
5.7	I/O Registers	58
5.7.1	ADC Status and Control Register	58
5.7.2	ADC Data Register	60
5.7.3	ADC Clock Register	60

## Chapter 6 Break Module (BRK)

6.1	Introduction . . . . .	63
6.2	Features . . . . .	63
6.3	Functional Description . . . . .	63
6.3.1	Flag Protection During Break Interrupts . . . . .	63
6.3.2	CPU During Break Interrupts . . . . .	64
6.3.3	TIMI and TIM2 During Break Interrupts . . . . .	65
6.3.4	COP During Break Interrupts . . . . .	65
6.4	Low-Power Modes . . . . .	65
6.4.1	Wait Mode . . . . .	65
6.4.2	Stop Mode . . . . .	65
6.5	Break Module Registers . . . . .	65
6.5.1	Break Status and Control Register . . . . .	65
6.5.2	Break Address Registers . . . . .	66
6.5.3	Break Status Register . . . . .	66
6.5.4	Break Flag Control Register . . . . .	67

## Chapter 7 Clock Generator Module (CGMC)

7.1	Introduction . . . . .	69
7.2	Features . . . . .	69
7.3	Functional Description . . . . .	69
7.3.1	Crystal Oscillator Circuit . . . . .	71
7.3.2	Phase-Locked Loop Circuit (PLL) . . . . .	71
7.3.3	PLL Circuits . . . . .	71
7.3.4	Acquisition and Tracking Modes . . . . .	72
7.3.5	Manual and Automatic PLL Bandwidth Modes . . . . .	72
7.3.6	Programming the PLL . . . . .	73
7.3.7	Special Programming Exceptions . . . . .	76
7.3.8	Base Clock Selector Circuit . . . . .	76
7.3.9	CGMC External Connections . . . . .	76
7.4	I/O Signals . . . . .	77
7.4.1	Crystal Amplifier Input Pin (OSC1) . . . . .	77
7.4.2	Crystal Amplifier Output Pin (OSC2) . . . . .	77
7.4.3	External Filter Capacitor Pin (CGMXFC) . . . . .	77
7.4.4	PLL Analog Power Pin ( $V_{DDA}$ ) . . . . .	78
7.4.5	PLL Analog Ground Pin ( $V_{SSA}$ ) . . . . .	78
7.4.6	Oscillator Enable Signal (SIMOSCEN) . . . . .	78
7.4.7	Oscillator Stop Mode Enable Bit (OSCSTOPENB) . . . . .	78
7.4.8	Crystal Output Frequency Signal (CGMXCLK) . . . . .	78
7.4.9	CGMC Base Clock Output (CGMOUT) . . . . .	78
7.4.10	CGMC CPU Interrupt (CGMINT) . . . . .	78
7.5	CGMC Registers . . . . .	79
7.5.1	PLL Control Register . . . . .	80
7.5.2	PLL Bandwidth Control Register . . . . .	82
7.5.3	PLL Multiplier Select Register High . . . . .	83

7.5.4	PLL Multiplier Select Register Low	83
7.5.5	PLL VCO Range Select Register	84
7.5.6	PLL Reference Divider Select Register	84
7.6	Interrupts	85
7.7	Special Modes	85
7.7.1	Wait Mode	85
7.7.2	Stop Mode	86
7.7.3	CGMC During Break Interrupts	86
7.8	Acquisition/Lock Time Specifications	86
7.8.1	Acquisition/Lock Time Definitions	86
7.8.2	Parametric Influences on Reaction Time	87
7.8.3	Choosing a Filter	87

## Chapter 8 Configuration Register (CONFIG)

8.1	Introduction	89
8.2	Functional Description	89

## Chapter 9 Computer Operating Properly (COP)

9.1	Introduction	93
9.2	Functional Description	93
9.3	I/O Signals	94
9.3.1	CGMXCLK	94
9.3.2	STOP Instruction	94
9.3.3	COPCTL Write	94
9.3.4	Power-On Reset	94
9.3.5	Internal Reset	94
9.3.6	Reset Vector Fetch	94
9.3.7	COPD (COP Disable)	95
9.3.8	COPRS (COP Rate Select)	95
9.4	COP Control Register	95
9.5	Interrupts	95
9.6	Monitor Mode	95
9.7	Low-Power Modes	95
9.7.1	Wait Mode	95
9.7.2	Stop Mode	95
9.8	COP Module During Break Mode	96

## Chapter 10 Central Processing Unit (CPU)

10.1	Features	97
10.2	CPU Registers	97
10.2.1	Accumulator	98
10.2.2	Index Register	98
10.2.3	Stack Pointer	99

## Table of Contents

10.2.4	Program Counter	99
10.2.5	Condition Code Register	100
10.3	Arithmetic/Logic Unit (ALU)	101
10.4	Low-Power Modes	101
10.4.1	Wait Mode	101
10.4.2	Stop Mode	101
10.5	CPU During Break Interrupts	101
10.6	Instruction Set Summary	102
10.7	Opcode Map	107

## Chapter 11 Flash Memory

11.1	Introduction	109
11.2	Functional Description	109
11.3	FLASH Control Register	110
11.4	FLASH Page Erase Operation	110
11.5	FLASH Mass Erase Operation	111
11.6	FLASH Program/Read Operation	111
11.7	FLASH Block Protection	114
11.7.1	FLASH Block Protect Register	114
11.8	Wait Mode	115
11.9	STOP Mode	115

## Chapter 12 External Interrupt (IRQ)

12.1	Introduction	117
12.2	Features	117
12.3	Functional Description	117
12.4	IRQ Pin	119
12.5	IRQ Module During Break Interrupts	119
12.6	IRQ Status and Control Register	120

## Chapter 13 Keyboard Interrupt (KBI)

13.1	Introduction	121
13.2	Features	121
13.3	Functional Description	121
13.4	Keyboard Initialization	123
13.5	Low-Power Modes	123
13.5.1	Wait Mode	123
13.5.2	Stop Mode	123
13.6	Keyboard Module During Break Interrupts	123
13.7	I/O Registers	124
13.7.1	Keyboard Status and Control Register	124
13.7.2	Keyboard Interrupt Enable Register	125

## Chapter 14 Low-Voltage Inhibit (LVI)

14.1	Introduction	127
14.2	Features	127
14.3	Functional Description	127
14.3.1	Polled LVI Operation	128
14.3.2	Forced Reset Operation	128
14.3.3	Voltage Hysteresis Protection	128
14.3.4	LVI Trip Selection	129
14.4	LVI Status Register	129
14.5	LVI Interrupts	129
14.6	Low-Power Modes	129
14.6.1	Wait Mode	129
14.6.2	Stop Mode	129

## Chapter 15 Monitor ROM (MON)

15.1	Introduction	131
15.2	Features	131
15.3	Functional Description	131
15.3.1	Entering Monitor Mode	133
15.3.2	Data Format	136
15.3.3	Break Signal	136
15.3.4	Baud Rate	136
15.3.5	Commands	137
15.4	Security	140

## Chapter 16 Input/Output Ports (I/O)

16.1	Introduction	143
16.2	Port A	146
16.2.1	Port A Data Register	146
16.2.2	Data Direction Register A	146
16.2.3	Port A Input Pullup Enable Register	147
16.3	Port B	148
16.3.1	Port B Data Register	148
16.3.2	Data Direction Register B	149
16.4	Port C	150
16.4.1	Port C Data Register	150
16.4.2	Data Direction Register C	150
16.4.3	Port C Input Pullup Enable Register	152
16.5	Port D	152
16.5.1	Port D Data Register	152
16.5.2	Data Direction Register D	153
16.5.3	Port D Input Pullup Enable Register	155

## Table of Contents

16.6	Port E	155
16.6.1	Port E Data Register	155
16.6.2	Data Direction Register E	156

## Chapter 17 Random-Access Memory (RAM)

17.1	Introduction	159
17.2	Functional Description	159

## Chapter 18 Serial Communications Interface (SCI)

18.1	Introduction	161
18.2	Features	161
18.3	Pin Name Conventions	162
18.4	Functional Description	162
18.4.1	Data Format	164
18.4.2	Transmitter	165
18.4.2.1	Character Length	166
18.4.2.2	Character Transmission	166
18.4.2.3	Break Characters	166
18.4.2.4	Idle Characters	167
18.4.2.5	Inversion of Transmitted Output	167
18.4.2.6	Transmitter Interrupts	167
18.4.3	Receiver	167
18.4.3.1	Character Length	168
18.4.3.2	Character Reception	169
18.4.3.3	Data Sampling	169
18.4.3.4	Framing Errors	170
18.4.3.5	Baud Rate Tolerance	171
18.4.3.6	Slow Data Tolerance	171
18.4.3.7	Fast Data Tolerance	172
18.4.3.8	Receiver Wakeup	172
18.4.3.9	Receiver Interrupts	173
18.4.3.10	Error Interrupts	173
18.5	Low-Power Modes	174
18.5.1	Wait Mode	174
18.5.2	Stop Mode	174
18.6	SCI During Break Module Interrupts	174
18.7	I/O Signals	174
18.7.1	PE2/TxD (Transmit Data)	174
18.7.2	PE1/RxD (Receive Data)	175
18.8	I/O Registers	175
18.8.1	SCI Control Register 1	175
18.8.2	SCI Control Register 2	177
18.8.3	SCI Control Register 3	179
18.8.4	SCI Status Register 1	180
18.8.5	SCI Status Register 2	182

18.8.6	SCI Data Register . . . . .	183
18.8.7	SCI Baud Rate Register . . . . .	183

## Chapter 19 System Integration Module (SIM)

19.1	Introduction . . . . .	187
19.2	SIM Bus Clock Control and Generation . . . . .	189
19.2.1	Bus Timing . . . . .	190
19.2.2	Clock Startup from POR or LVI Reset . . . . .	190
19.2.3	Clocks in Stop Mode and Wait Mode . . . . .	190
19.3	Reset and System Initialization . . . . .	190
19.3.1	External Pin Reset . . . . .	190
19.3.2	Active Resets from Internal Sources . . . . .	191
19.3.2.1	Power-On Reset . . . . .	192
19.3.2.2	Computer Operating Properly (COP) Reset . . . . .	192
19.3.2.3	Illegal Opcode Reset . . . . .	193
19.3.2.4	Illegal Address Reset . . . . .	193
19.3.2.5	Low-Voltage Inhibit (LVI) Reset . . . . .	193
19.3.2.6	Monitor Mode Entry Module Reset (MODRST) . . . . .	193
19.4	SIM Counter . . . . .	193
19.4.1	SIM Counter During Power-On Reset . . . . .	193
19.4.2	SIM Counter During Stop Mode Recovery . . . . .	193
19.4.3	SIM Counter and Reset States . . . . .	194
19.5	Exception Control . . . . .	194
19.5.1	Interrupts . . . . .	194
19.5.1.1	Hardware Interrupts . . . . .	196
19.5.1.2	SWI Instruction . . . . .	196
19.5.1.3	Interrupt Status Registers . . . . .	197
19.5.1.4	Interrupt Status Register 1 . . . . .	197
19.5.1.5	Interrupt Status Register 2 . . . . .	198
19.5.1.6	Interrupt Status Register 3 . . . . .	198
19.5.2	Reset . . . . .	198
19.5.3	Break Interrupts . . . . .	198
19.5.4	Status Flag Protection in Break Mode . . . . .	199
19.6	Low-Power Modes . . . . .	199
19.6.1	Wait Mode . . . . .	199
19.6.2	Stop Mode . . . . .	200
19.7	SIM Registers . . . . .	201
19.7.1	SIM Break Status Register . . . . .	201
19.7.2	SIM Reset Status Register . . . . .	202
19.7.3	SIM Break Flag Control Register . . . . .	203

## Chapter 20 Serial Peripheral Interface (SPI)

20.1	Introduction . . . . .	205
20.2	Features . . . . .	205
20.3	Pin Name Conventions and I/O Register Addresses . . . . .	206

## Table of Contents

20.4	Functional Description	206
20.4.1	Master Mode	208
20.4.2	Slave Mode	208
20.5	Transmission Formats	209
20.5.1	Clock Phase and Polarity Controls	209
20.5.2	Transmission Format When CPHA = 0	209
20.5.3	Transmission Format When CPHA = 1	210
20.5.4	Transmission Initiation Latency	211
20.6	Queuing Transmission Data	213
20.7	Error Conditions	214
20.7.1	Overflow Error	214
20.7.2	Mode Fault Error	215
20.8	Interrupts	217
20.9	Resetting the SPI	218
20.10	Low-Power Modes	218
20.10.1	Wait Mode	218
20.10.2	Stop Mode	218
20.11	SPI During Break Interrupts	219
20.12	I/O Signals	219
20.12.1	MISO (Master In/Slave Out)	219
20.12.2	MOSI (Master Out/Slave In)	219
20.12.3	SPSCK (Serial Clock)	220
20.12.4	$\overline{SS}$ (Slave Select)	220
20.13	I/O Registers	221
20.13.1	SPI Control Register	221
20.13.2	SPI Status and Control Register	222
20.13.3	SPI Data Register	224

## Chapter 21 Timebase Module (TBM)

21.1	Introduction	225
21.2	Features	225
21.3	Functional Description	225
21.4	Interrupts	225
21.5	Low-Power Modes	226
21.5.1	Wait Mode	226
21.5.2	Stop Mode	226
21.6	Timebase Register Description	227

## Chapter 22 Timer Interface Module (TIM)

22.1	Introduction	229
22.2	Features	229
22.3	Pin Name Conventions	229



22.4	Functional Description . . . . .	230
22.4.1	TIM Counter Prescaler . . . . .	230
22.4.2	Input Capture . . . . .	230
22.4.3	Output Compare . . . . .	230
22.4.3.1	Unbuffered Output Compare . . . . .	234
22.4.3.2	Buffered Output Compare . . . . .	234
22.4.4	Pulse Width Modulation (PWM) . . . . .	234
22.4.4.1	Unbuffered PWM Signal Generation . . . . .	235
22.4.4.2	Buffered PWM Signal Generation . . . . .	236
22.4.4.3	PWM Initialization . . . . .	236
22.5	Interrupts . . . . .	237
22.6	Low-Power Modes . . . . .	237
22.6.1	Wait Mode . . . . .	237
22.6.2	Stop Mode . . . . .	237
22.7	TIM During Break Interrupts . . . . .	238
22.8	I/O Signals . . . . .	238
22.9	I/O Registers . . . . .	238
22.9.1	TIM Status and Control Register . . . . .	238
22.9.2	TIM Counter Registers . . . . .	240
22.9.3	TIM Counter Modulo Registers . . . . .	241
22.9.4	TIM Channel Status and Control Registers . . . . .	241
22.9.5	TIM Channel Registers . . . . .	244

## Chapter 23 Electrical Specifications

23.1	Absolute Maximum Ratings . . . . .	247
23.2	Functional Operating Range . . . . .	248
23.3	Thermal Characteristics . . . . .	248
23.4	5.0 V DC Electrical Characteristics . . . . .	249
23.5	3.0 V DC Electrical Characteristics . . . . .	251
23.6	5.0 V Control Timing . . . . .	253
23.7	3.0 V Control Timing . . . . .	254
23.8	Clock Generation Module Characteristics . . . . .	255
23.8.1	CGM Component Specifications . . . . .	255
23.8.2	CGM Electrical Specifications . . . . .	255
23.9	Output High-Voltage Characteristics . . . . .	256
23.10	Output Low-Voltage Characteristics . . . . .	259
23.11	Typical Supply Currents . . . . .	261
23.12	ADC Characteristics . . . . .	263
23.13	5.0 V SPI Characteristics . . . . .	264
23.14	3.0 V SPI Characteristics . . . . .	265
23.15	Timer Interface Module Characteristics . . . . .	268
23.16	Memory Characteristics . . . . .	268

**Chapter 24**  
**Mechanical Specifications**

24.1 Introduction ..... 269

**Chapter 25**  
**Ordering Information**

25.1 Introduction ..... 281  
25.2 MC Order Numbers ..... 281  
25.3 Development Tools ..... 282

**Revision History**

Revision History ..... 283

# Chapter 1

## General Description

### 1.1 Introduction

The MC68HC908GR8 is a member of the low-cost, high-performance M68HC08 Family of 8-bit microcontroller units (MCUs). All MCUs in the family use the enhanced M68HC08 central processor unit (CPU08) and are available with a variety of modules, memory sizes and types, and package types.

This document also describes the MC68HC908GR4. The MC68HC908GR4 is a device identical to the MC68HC908GR8 except that it has less Flash memory. Only when there are differences from the MC68HC908GR8 is the MC68HC908GR4 specifically mentioned in the text.

### 1.2 Features

For convenience, features have been organized to reflect:

- Standard features of the MC68HC908GR8
- Features of the CPU08

#### 1.2.1 Standard Features of the MC68HC908GR8

- High-performance M68HC08 architecture optimized for C-compilers
- Fully upward-compatible object code with M6805, M146805, and M68HC05 Families
- 8-MHz internal bus frequency
- FLASH program memory security<sup>(1)</sup>
- On-chip programming firmware for use with host personal computer which does not require high voltage for entry
- In-system programming
- System protection features:
  - Optional computer operating properly (COP) reset
  - Low-voltage detection with optional reset and selectable trip points for 3.0 V and 5.0 V operation
  - Illegal opcode detection with reset
  - Illegal address detection with reset
- Low-power design; fully static with stop and wait modes
- Standard low-power modes of operation:
  - Wait mode
  - Stop mode
- Master reset pin and power-on reset (POR)

---

1. No security feature is absolutely secure. However, Freescale's strategy is to make reading or copying the FLASH difficult for unauthorized users.

## General Description

- 7680 bytes of on-chip FLASH memory on the MC68HC908GR8 and 4096 bytes of on-chip FLASH memory on the MC68HC908GR4 with in-circuit programming capabilities of FLASH program memory
- 384 bytes of on-chip random-access memory (RAM)
- Serial peripheral interface module (SPI)
- Serial communications interface module (SCI)
- One 16-bit, 2-channel timer (TIM1) and one 16-bit, 1-channel timer (TIM2) interface modules with selectable input capture, output compare, and PWM capability on each channel
- 6-channel, 8-bit successive approximation analog-to-digital converter (ADC)
- BREAK module (BRK) to allow single breakpoint setting during in-circuit debugging
- Internal pullups on  $\overline{\text{IRQ}}$  and  $\overline{\text{RST}}$  to reduce customer system cost
- Clock generator module with on-chip 32-kHz crystal compatible PLL (phase-lock loop)
- Up to 21 general-purpose input/output (I/O) pins, including:
  - 19 shared-function I/O pins
  - Up to two dedicated I/O pins, depending on package choice
- Selectable pullups on inputs only on ports A, C, and D. Selection is on an individual port bit basis. During output mode, pullups are disengaged.
- High current 10-mA sink/10-mA source capability on all port pins
- Higher current 15-mA sink/source capability on PTC0–PTC1
- Timebase module with clock prescaler circuitry for eight user selectable periodic real-time interrupts with optional active clock source during stop mode for periodic wakeup from stop using an external 32-kHz crystal
- Oscillator stop mode enable bit (OSCSTOPENB) in the CONFIG register to allow user selection of having the oscillator enabled or disabled during stop mode
- 4-bit keyboard wakeup port
- 42-pin shrink dual in-line package (SDIP), 32-pin quad flat pack (QFP), 28-pin plastic dual-in-line package (DIP), or 28-pin small outline integrated circuit (SOIC)
- Specific features of the MC68HC908GR8 in 28-pin DIP and 28-pin SOIC are:
  - Port B is only 4 bits: PTB0–PTB3; 4-channel ADC module
  - No Port C bits

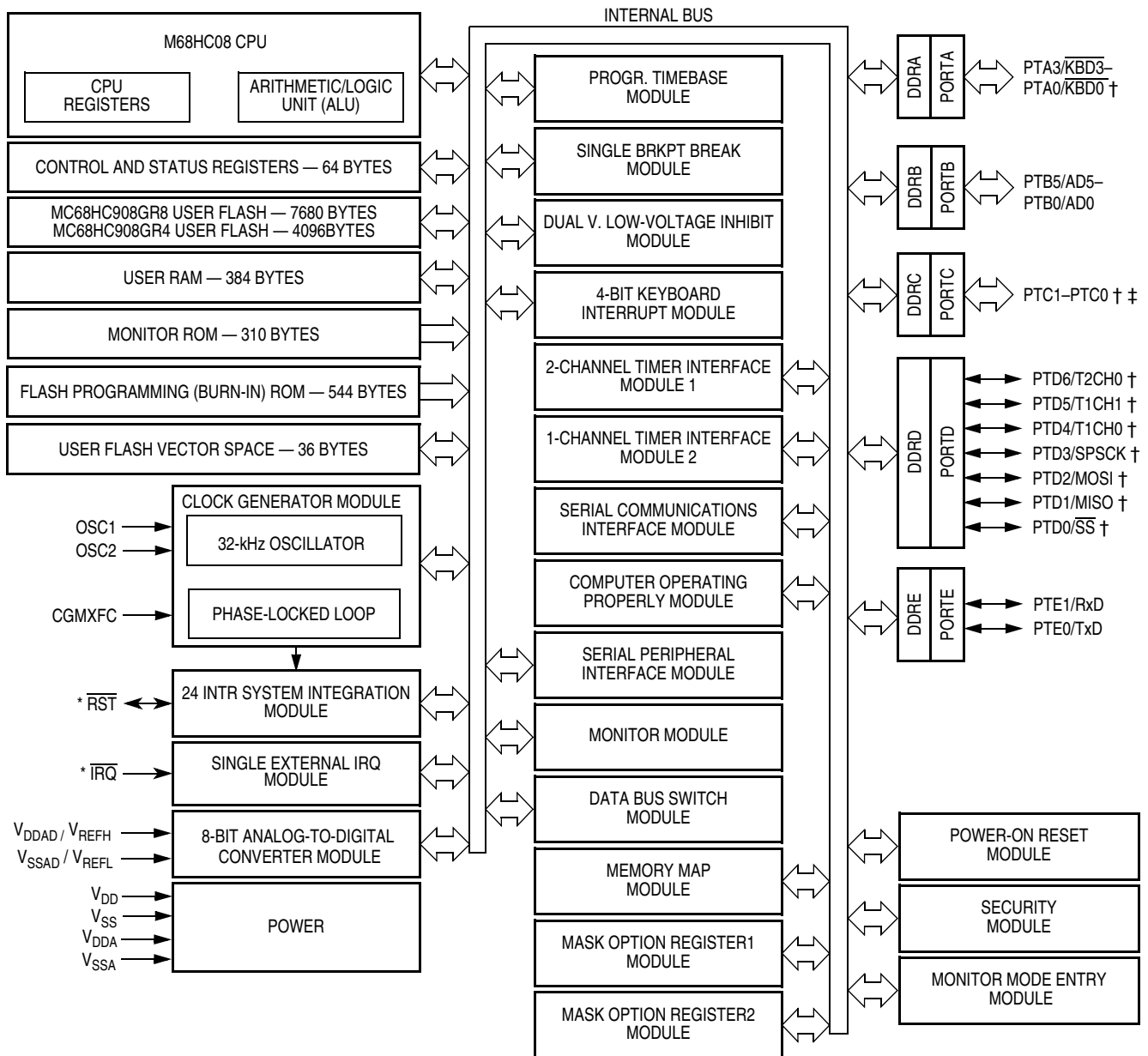
### 1.2.2 Features of the CPU08

Features of the CPU08 include:

- Enhanced HC05 programming model
- Extensive loop control functions
- 16 addressing modes (eight more than the HC05)
- 16-bit index register and stack pointer
- Memory-to-memory data transfers
- Fast  $8 \times 8$  multiply instruction
- Fast 16/8 divide instruction
- Binary-coded decimal (BCD) instructions
- Optimization for controller applications
- Efficient C language support

### 1.3 MCU Block Diagram

Figure 1-1 shows the structure of the MC68HC908GR8.



† Ports are software configurable with pullup device if input port.  
 ‡ Higher current drive port pins  
 \* Pin contains integrated pullup device

Figure 1-1. MCU Block Diagram

## 1.4 Pin Assignments

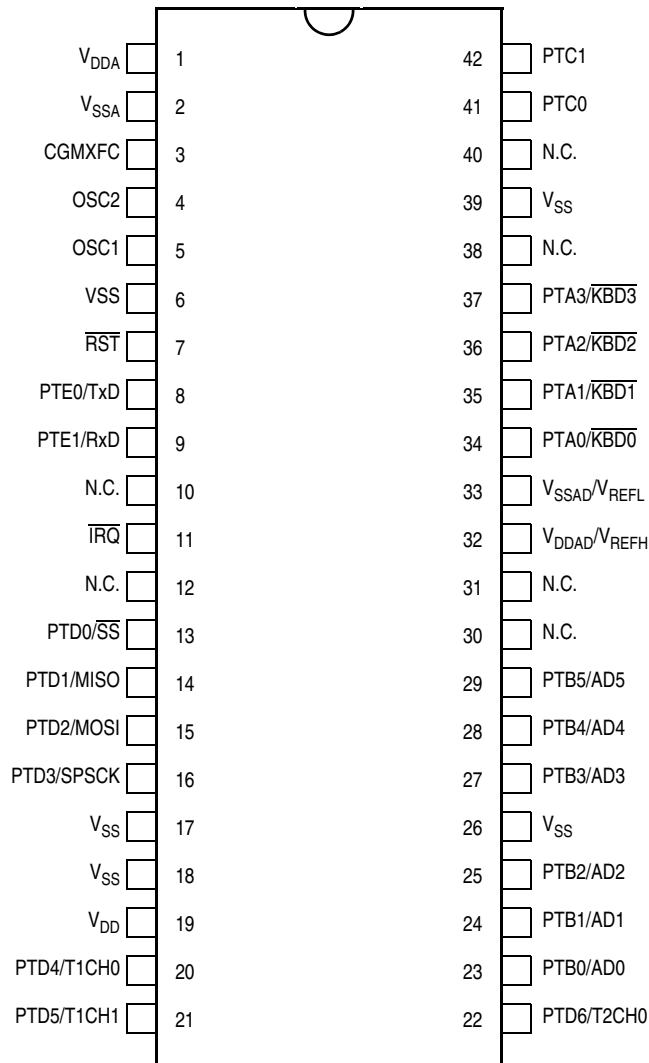
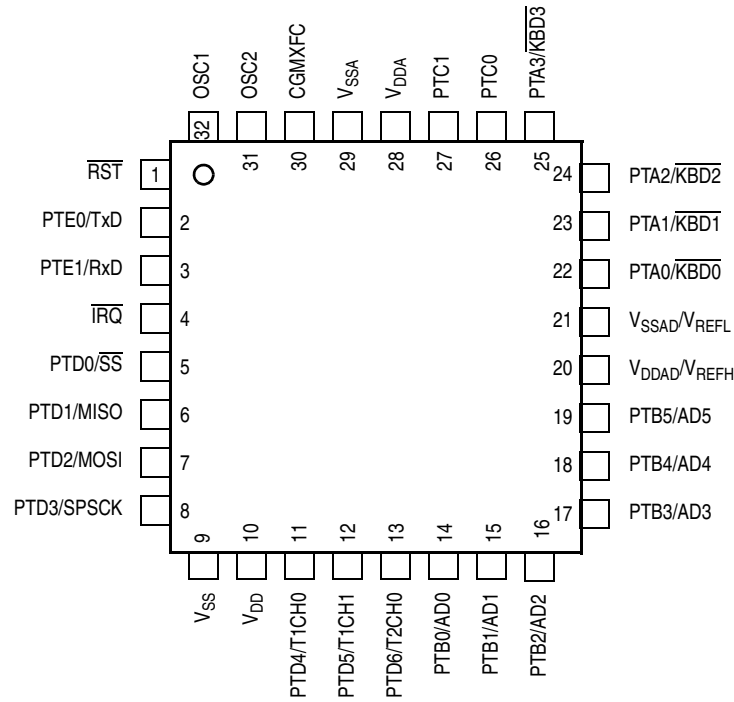
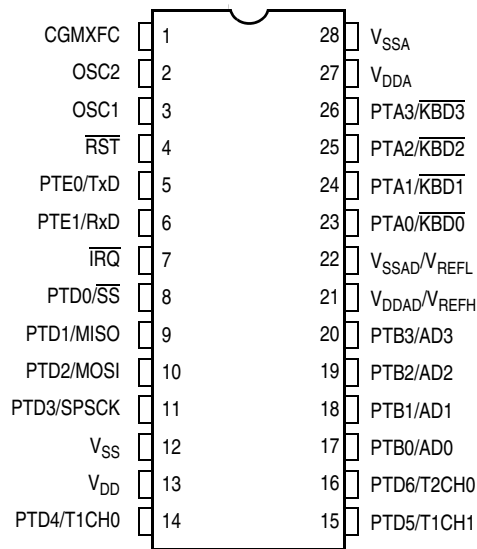


Figure 1-2. SDIP Pin Assignments



NOTE: Ports PTB4, PTB5, PTC0, and PTC1 are available only with the QFP.

**Figure 1-3. QFP Pin Assignments**



OTE: Ports PTB4, PTB5, PTC0, and PTC1 are available only with the QFP.

**Figure 1-4. DIP And SOIC Pin Assignments**

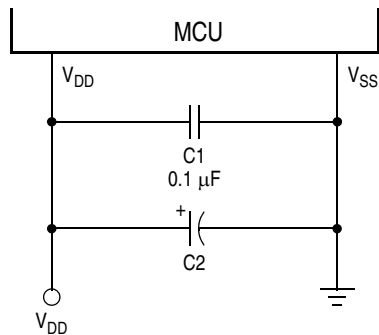
## 1.5 Pin Functions

Descriptions of the pin functions are provided here.

### 1.5.1 Power Supply Pins ( $V_{DD}$ and $V_{SS}$ )

$V_{DD}$  and  $V_{SS}$  are the power supply and ground pins. The MCU operates from a single power supply.

Fast signal transitions on MCU pins place high, short-duration current demands on the power supply. To prevent noise problems, take special care to provide power supply bypassing at the MCU as [Figure 1-5](#) shows. Place the C1 bypass capacitor as close to the MCU as possible. Use a high-frequency-response ceramic capacitor for C1. C2 is an optional bulk current bypass capacitor for use in applications that require the port pins to source high current levels.



NOTE: Component values shown represent typical applications.

**Figure 1-5. Power Supply Bypassing**

### 1.5.2 Oscillator Pins (OSC1 and OSC2)

The OSC1 and OSC2 pins are the connections for the on-chip oscillator circuit. See [Chapter 7 Clock Generator Module \(CGMC\)](#).

### 1.5.3 External Reset Pin ( $\overline{RST}$ )

A logic 0 on the  $\overline{RST}$  pin forces the MCU to a known startup state.  $\overline{RST}$  is bidirectional, allowing a reset of the entire system. It is driven low when any internal reset source is asserted. This pin contains an internal pullup resistor that is always activated, even when the reset pin is pulled low. See [Chapter 4 Resets and Interrupts](#).

### 1.5.4 External Interrupt Pin ( $\overline{IRQ}$ )

$\overline{IRQ}$  is an asynchronous external interrupt pin. This pin contains an internal pullup resistor that is always activated, even when the reset pin is pulled low. See [Chapter 12 External Interrupt \(IRQ\)](#).

### 1.5.5 CGM Power Supply Pins ( $V_{DDA}$ and $V_{SSA}$ )

$V_{DDA}$  and  $V_{SSA}$  are the power supply pins for the analog portion of the clock generator module (CGM). Decoupling of these pins should be as per the digital supply. See [Chapter 7 Clock Generator Module \(CGMC\)](#).



### 1.5.6 External Filter Capacitor Pin (CGMXFC)

CGMXFC is an external filter capacitor connection for the CGM. See [Chapter 7 Clock Generator Module \(CGMC\)](#).

### 1.5.7 Analog Power Supply/Reference Pins ( $V_{DDAD}/V_{REFH}$ and $V_{SSAD}/V_{REFL}$ )

$V_{DDAD}$  and  $V_{SSAD}$  are the power supply pins for the analog-to-digital converter. Decoupling of these pins should be as per the digital supply.

#### NOTE

$V_{REFH}$  is the high reference supply for the ADC. The  $V_{REFH}$  signal is internally connected with  $V_{DDAD}$  and have the same potential as  $V_{DDAD}$ .  $V_{DDAD}$  should be tied to the same potential as  $V_{DD}$  via separate traces.  $V_{REFL}$  is the low reference supply for the ADC. The  $V_{REFL}$  pin is internally connected with  $V_{SSAD}$  and has the same potential as  $V_{SSAD}$ .  $V_{SSAD}$  should be tied to the same potential as  $V_{SS}$  via separate traces.

See [Chapter 5 Analog-to-Digital Converter \(ADC\)](#).

### 1.5.8 Port A Input/Output (I/O) Pins (PTA3/KBD3–PTA0/KBD0)

PTA3–PTA0 are special-function, bidirectional I/O port pins. Any or all of the port A pins can be programmed to serve as keyboard interrupt pins. See [Chapter 16 Input/Output Ports \(I/O\)](#) and See [Chapter 12 External Interrupt \(IRQ\)](#).

These port pins also have selectable pullups when configured for input mode. The pullups are disengaged when configured for output mode. The pullups are selectable on an individual port bit basis.

When the port pins are configured for special-function mode (KBI), pullups will be automatically engaged. As long as the port pins are in special-function mode, the pullups will always be on.

### 1.5.9 Port B I/O Pins (PTB5/AD5–PTB0/AD0)

PTB5–PTB0 are special-function, bidirectional I/O port pins that can also be used for analog-to-digital converter (ADC) inputs. See [Chapter 16 Input/Output Ports \(I/O\)](#) and See [Chapter 5 Analog-to-Digital Converter \(ADC\)](#).

There are no pullups associated with this port.

### 1.5.10 Port C I/O Pins (PTC1–PTC0)

PTC1–PTC0 are general-purpose, bidirectional I/O port pins. See [Chapter 16 Input/Output Ports \(I/O\)](#). PTC0 and PTC1 are only available on 32-pin QFP packages.

These port pins also have selectable pullups when configured for input mode. The pullups are disengaged when configured for output mode. The pullups are selectable on an individual port bit basis.

### 1.5.11 Port D I/O Pins (PTD6/T2CH0–PTD0/ $\overline{SS}$ )

PTD6–PTD0 are special-function, bidirectional I/O port pins. PTD3–PTD0 can be programmed to be serial peripheral interface (SPI) pins, while PTD6–PTD4 can be individually programmed to be timer interface module (TIM1 and TIM2) pins. See [Chapter 22 Timer Interface Module \(TIM\)](#), [Chapter 20 Serial Peripheral Interface \(SPI\)](#), and See [Chapter 16 Input/Output Ports \(I/O\)](#).

## General Description

These port pins also have selectable pullups when configured for input mode. The pullups are disengaged when configured for output mode. The pullups are selectable on an individual port bit basis.

When the port pins are configured for special-function mode (SPI, TIM1, TIM2), pullups can be selectable on an individual port pin basis.

### 1.5.12 Port E I/O Pins (PTE1/RxD–PTE0/TxD)

PTE1–PTE0 are special-function, bidirectional I/O port pins. These pins can also be programmed to be serial communications interface (SCI) pins. See [Chapter 18 Serial Communications Interface \(SCI\)](#) and See [Chapter 16 Input/Output Ports \(I/O\)](#).

#### **NOTE**

*Any unused inputs and I/O ports should be tied to an appropriate logic level (either  $V_{DD}$  or  $V_{SS}$ ). Although the I/O ports of the MC68HC908GR8 do not require termination, termination is recommended to reduce the possibility of electro-static discharge damage.*

# Chapter 2

## Memory Map

### 2.1 Introduction

The CPU08 can address 64K bytes of memory space. The memory map, shown in [Figure 2-1](#), includes:

- 8K bytes of FLASH memory, 7680 bytes of user space on the MC68HC908GR8 or 4K bytes of FLASH memory, 4096 bytes of user space on the MC68HC908GR4
- 384 bytes of random-access memory (RAM)
- 36 bytes of user-defined vectors
- 310 bytes of monitor routines in read-only memory (ROM)
- 544 bytes of integrated FLASH burn-in routines in ROM

### 2.2 Unimplemented Memory Locations

Accessing an unimplemented location can cause an illegal address reset if illegal address resets are enabled. In the memory map ([Figure 2-1](#)) and in register figures in this document, unimplemented locations are shaded.

### 2.3 Reserved Memory Locations

Accessing a reserved location can have unpredictable effects on MCU operation. In the [Figure 2-1](#) and in register figures in this document, reserved locations are marked with the word Reserved or with the letter R.

### 2.4 Input/Output (I/O) Section

Most of the control, status, and data registers are in the zero page area of \$0000–\$003F. Additional I/O registers have these addresses:

- \$FE00; SIM break status register, SBSR
- \$FE01; SIM reset status register, SRSR
- \$FE03; SIM break flag control register, SBFCR
- \$FE04; interrupt status register 1, INT1
- \$FE05; interrupt status register 2, INT2
- \$FE06; interrupt status register 3, INT3
- \$FE07; reserved FLASH test control register, FLTCR
- \$FE08; FLASH control register, FLCR
- \$FE09; break address register high, BRKH
- \$FE0A; break address register low, BRKL
- \$FE0B; break status and control register, BRKSCR
- \$FE0C; LVI status register, LVISR
- \$FF7E; FLASH block protect register, FLBPR

Data registers are shown in [Figure 2-2](#), and [Table 2-1](#) is a list of vector locations.

## 2.5 Memory Map

\$0000 ↓	I/O Registers 64 Bytes	
\$003F ↓	RAM 384 Bytes	
\$0040 ↓	Unimplemented 6720 Bytes	
\$01BF ↓	Reserved for Integrated FLASH Burn-in Routines 544 Bytes	
\$01C0 ↓	Unimplemented 49,632 Bytes	
\$1BFF ↓	MC68HC908GR8 FLASH Memory 7680 Bytes	MC68HC908GR4 Unimplemented 3584 Bytes
\$1C00 ↓		MC68HC908GR4 FLASH Memory 4096 Bytes
\$1E1F ↓	SIM Break Status Register (SBSR)	
\$1E20 ↓	SIM Reset Status Register (SRSR)	
\$DFFF ↓	Reserved	
\$E000 ↓	SIM Break Flag Control Register (SBFCR)	
\$EDFF ↓	Interrupt Status Register 1 (INT1)	
\$EE00 ↓	Interrupt Status Register 2 (INT2)	
\$FDFF ↓	Interrupt Status Register 3 (INT3)	
\$FE00	Reserved for FLASH Test Control Register (FLTCR)	
\$FE01	FLASH Control Register (FLCR)	
\$FE02	Break Address Register High (BRKH)	
\$FE03	Break Address Register Low (BRKL)	
\$FE04	Break Status and Control Register (BRKSCR)	
\$FE05	LVI Status Register (LVISR)	

Continued on next page

**Figure 2-1. Memory Map**

\$FE0D	↓	Reserved 3 Bytes
\$FE0F		
\$FE10	↓	Unimplemented 16 Bytes Reserved for Compatibility with Monitor Code for A-Family Parts
\$FE1F		
\$FE20	↓	Monitor ROM 310 Bytes
\$FF55		
\$FF56	↓	Unimplemented 40 Bytes
\$FF7D		
\$FF7E	FLASH Block Protect Register (FLBPR)	
\$FF7F	↓	Unimplemented 93 Bytes
\$FFDB		
\$FFDC	↓	FLASH Vectors (36 Bytes including \$FFFF)
\$FFFE		
\$FFFF	Low byte of reset vector when read COP Control Register (COPCTL)	

Note: \$FFF6–\$FFFD contains 8 security bytes

Figure 2-1. Memory Map (Continued)

## 2.6 Register Summary

Addr.	Register Name	Bit 7	6	5	4	3	2	1	Bit 0	
\$0000	Port A Data Register (PTA)	Read:	0	0	0	0	PTA3	PTA2	PTA1	PTA0
		Write:								
		Reset:	Unaffected by reset							
\$0001	Port B Data Register (PTB)	Read:	0	0	PTB5	PTB4	PTB3	PTB2	PTB1	PTB0
		Write:								
		Reset:	Unaffected by reset							
\$0002	Port C Data Register (PTC)	Read:	0	0	0	0	0	PTC1	PTC0	
		Write:								
		Reset:	Unaffected by reset							
\$0003	Port D Data Register (PTD)	Read:	0	PTD6	PTD5	PTD4	PTD3	PTD2	PTD1	PTD0
		Write:								
		Reset:	Unaffected by reset							

= Unimplemented      R = Reserved      U = Unaffected

Figure 2-2. Control, Status, and Data Registers (Sheet 1 of 7)

## Memory Map

Addr.	Register Name	Bit 7	6	5	4	3	2	1	Bit 0	
\$0004	Data Direction Register A (DDRA)	Read:	0	0	0	0	DDRA3	DDRA2	DDRA1	DDRA0
		Write:								
		Reset:	0	0	0	0	0	0	0	0
\$0005	Data Direction Register B (DDRB)	Read:	0	0	DDRB5	DDRB4	DDRB3	DDRB2	DDRB1	DDRB0
		Write:								
		Reset:	0	0	0	0	0	0	0	0
\$0006	Data Direction Register C (DDRC)	Read:	0	0	0	0	0	DDRC1	DDRC0	
		Write:								
		Reset:	0	0	0	0	0	0	0	0
\$0007	Data Direction Register D (DDRD)	Read:	0	DDRD6	DDRD5	DDRD4	DDRD3	DDRD2	DDRD1	DDRD0
		Write:								
		Reset:	0	0	0	0	0	0	0	0
\$0008	Port E Data Register (PTE)	Read:	0	0	0	0	0	PTE1	PTE0	
		Write:								
		Reset:	Unaffected by reset							
\$0009 ↓ \$000B	Unimplemented	Read:								
		Write:								
		Reset:	0	0	0	0	0	0	0	0
\$000C	Data Direction Register E (DDRE)	Read:	0	0	0	0	0	DDRE1	DDRE0	
		Write:								
		Reset:	0	0	0	0	0	0	0	0
\$000D	Port A Input Pullup Enable Register (PTAPUE)	Read:	0	0	0	0	PTAPUE3	PTAPUE2	PTAPUE1	PTAPUE0
		Write:								
		Reset:	0	0	0	0	0	0	0	0
\$000E	Port C Input Pullup Enable Register (PTCPUE)	Read:	0	0	0	0	0	PTCPUE1	PTCPUE0	
		Write:								
		Reset:	0	0	0	0	0	0	0	0
\$000F	Port D Input Pullup Enable Register (PTDPUE)	Read:	0	PTDPUE6	PTDPUE5	PTDPUE4	PTDPUE3	PTDPUE2	PTDPUE1	PTDPUE0
		Write:								
		Reset:	0	0	0	0	0	0	0	0
\$0010	SPI Control Register (SPCR)	Read:	SPRIE	R	SPMSTR	CPOL	CPHA	SPWOM	SPE	SPTIE
		Write:								
		Reset:	0	0	1	0	1	0	0	0
\$0011	SPI Status and Control Register (SPSCR)	Read:	SPRF	ERRIE	OVRF	MODF	SPTIE	MODFEN	SPR1	SPR0
		Write:								
		Reset:	0	0	0	0	1	0	0	0

= Unimplemented      R = Reserved      U = Unaffected

**Figure 2-2. Control, Status, and Data Registers (Sheet 2 of 7)**

## Register Summary

Addr.	Register Name	Bit 7	6	5	4	3	2	1	Bit 0	
\$0012	SPI Data Register (SPDR)	Read:	R7	R6	R5	R4	R3	R2	R1	R0
		Write:	T7	T6	T5	T4	T3	T2	T1	T0
		Reset:	Unaffected by reset							
\$0013	SCI Control Register 1 (SCC1)	Read:	LOOPS	ENSCI	TXINV	M	WAKE	ILTY	PEN	PTY
		Write:								
		Reset:	0	0	0	0	0	0	0	0
\$0014	SCI Control Register 2 (SCC2)	Read:	SCTIE	TCIE	SCRIE	ILIE	TE	RE	RWU	SBK
		Write:								
		Reset:	0	0	0	0	0	0	0	0
\$0015	SCI Control Register 3 (SCC3)	Read:	R8	T8	R	R	ORIE	NEIE	FEIE	PEIE
		Write:								
		Reset:	U	U	0	0	0	0	0	0
\$0016	SCI Status Register 1 (SCS1)	Read:	SCTE	TC	SCRf	IDLE	OR	NF	FE	PE
		Write:								
		Reset:	1	1	0	0	0	0	0	0
\$0017	SCI Status Register 2 (SCS2)	Read:	0	0	0	0	0	0	BKF	RPF
		Write:								
		Reset:	0	0	0	0	0	0	0	0
\$0018	SCI Data Register (SCDR)	Read:	R7	R6	R5	R4	R3	R2	R1	R0
		Write:	T7	T6	T5	T4	T3	T2	T1	T0
		Reset:	Unaffected by reset							
\$0019	SCI Baud Rate Register (SCBR)	Read:	0	0	SCP1	SCP0	R	SCR2	SCR1	SCR0
		Write:								
		Reset:	0	0	0	0	0	0	0	0
\$001A	Keyboard Status and Control Register (INTKBSCR)	Read:	0	0	0	0	KEYF	0	IMASKK	MODEK
		Write:						ACKK		
		Reset:	0	0	0	0	0	0	0	0
\$001B	Keyboard Interrupt Enable Register (INTKBIER)	Read:	0	0	0	0	KBIE3	KBIE2	KBIE1	KBIE0
		Write:								
		Reset:					0	0	0	0
\$001C	Time Base Module Control Register (TBCR)	Read:	TBIF	TBR2	TBR1	TBR0	0	TBIE	TBON	R
		Write:					TACK			
		Reset:	0	0	0	0	0	0	0	0
\$001D	IRQ Status and Control Register (INTSCR)	Read:	0	0	0	0	IRQF1	0	IMASK1	MODE1
		Write:						ACK1		
		Reset:	0	0	0	0	0	0	0	0

= Unimplemented      R = Reserved      U = Unaffected

**Figure 2-2. Control, Status, and Data Registers (Sheet 3 of 7)**

## Memory Map

Addr.	Register Name	Bit 7	6	5	4	3	2	1	Bit 0	
\$001E	Configuration Register 2 (CONFIG2)†	Read:	0	0	0	0	0	OSC-STOPENB	SCIBDSRC	
		Write:								
		Reset:	0	0	0	0	0	0	0	0
\$001F	Configuration Register 1 (CONFIG1)†	Read:	COPRS	LVISTOP	LVIRSTD	LVIPWRD	LVI5OR3†	SSREC	STOP	COPD
		Write:								
		Reset:	0	0	0	0	0	0	0	0
\$0020	Timer 1 Status and Control Register (T1SC)	Read:	TOF	TOIE	TSTOP	0	0	PS2	PS1	PS0
		Write:	0			TRST				
		Reset:	0	0	1	0	0	0	0	0
\$0021	Timer 1 Counter Register High (T1CNTH)	Read:	Bit 15	14	13	12	11	10	9	Bit 8
		Write:								
		Reset:	0	0	0	0	0	0	0	0
\$0022	Timer 1 Counter Register Low (T1CNTL)	Read:	Bit 7	6	5	4	3	2	1	Bit 0
		Write:								
		Reset:	0	0	0	0	0	0	0	0
\$0023	Timer 1 Counter Modulo Register High (T1MODH)	Read:	Bit 15	14	13	12	11	10	9	Bit 8
		Write:								
		Reset:	1	1	1	1	1	1	1	1
\$0024	Timer 1 Counter Modulo Register Low (T1MODL)	Read:	Bit 7	6	5	4	3	2	1	Bit 0
		Write:								
		Reset:	1	1	1	1	1	1	1	1
\$0025	Timer 1 Channel 0 Status and Control Register (T1SC0)	Read:	CH0F	CH0IE	MS0B	MS0A	ELS0B	ELS0A	TOV0	CH0MAX
		Write:	0							
		Reset:	0	0	0	0	0	0	0	0
\$0026	Timer 1 Channel 0 Register High (T1CH0H)	Read:	Bit 15	14	13	12	11	10	9	Bit 8
		Write:								
		Reset:	Indeterminate after reset							
\$0027	Timer 1 Channel 0 Register Low (T1CH0L)	Read:	Bit 7	6	5	4	3	2	1	Bit 0
		Write:								
		Reset:	Indeterminate after reset							
† One-time writeable register after each reset, except LVI5OR3 bit. LVI5OR3 bit is only reset via POR (power-on reset).										
\$0028	Timer 1 Channel 1 Status and Control Register (T1SC1)	Read:	CH1F	CH1IE	0	MS1A	ELS1B	ELS1A	TOV1	CH1MAX
		Write:	0							
		Reset:	0	0	0	0	0	0	0	0
\$0029	Timer 1 Channel 1 Register High (T1CH1H)	Read:	Bit 15	14	13	12	11	10	9	Bit 8
		Write:								
		Reset:	Indeterminate after reset							
<div style="display: flex; justify-content: space-around; align-items: center;"> <span><span style="display: inline-block; width: 15px; height: 15px; background-color: #cccccc; border: 1px solid black;"></span> = Unimplemented</span> <span>R = Reserved</span> <span>U = Unaffected</span> </div>										

**Figure 2-2. Control, Status, and Data Registers (Sheet 4 of 7)**



## Register Summary

Addr.	Register Name	Bit 7	6	5	4	3	2	1	Bit 0	
\$002A	Timer 1 Channel 1 Register Low (T1CH1L)	Read:	Bit 7	6	5	4	3	2	1	Bit 0
		Write:								
		Reset:	Indeterminate after reset							
\$002B	Timer 2 Status and Control Register (T2SC)	Read:	TOF	TOIE	TSTOP	0	0	PS2	PS1	PS0
		Write:	0			TRST				
		Reset:	0	0	1	0	0	0	0	0
\$002C	Timer 2 Counter Register High (T2CNTH)	Read:	Bit 15	14	13	12	11	10	9	Bit 8
		Write:								
		Reset:	0	0	0	0	0	0	0	0
\$002D	Timer 2 Counter Register Low (T2CNTL)	Read:	Bit 7	6	5	4	3	2	1	Bit 0
		Write:								
		Reset:	0	0	0	0	0	0	0	0
\$002E	Timer 2 Counter Modulo Register High (T2MODH)	Read:	Bit 15	14	13	12	11	10	9	Bit 8
		Write:								
		Reset:	1	1	1	1	1	1	1	1
\$002F	Timer 2 Counter Modulo Register Low (T2MODL)	Read:	Bit 7	6	5	4	3	2	1	Bit 0
		Write:								
		Reset:	1	1	1	1	1	1	1	1
\$0030	Timer 2 Channel 0 Status and Control Register (T2SC0)	Read:	CH0F	CH0IE	MS0B	MS0A	ELS0B	ELS0A	TOV0	CH0MAX
		Write:	0							
		Reset:	0	0	0	0	0	0	0	0
\$0031	Timer 2 Channel 0 Register High (T2CH0H)	Read:	Bit 15	14	13	12	11	10	9	Bit 8
		Write:								
		Reset:	Indeterminate after reset							
\$0032	Timer 2 Channel 0 Register Low (T2CH0L)	Read:	Bit 7	6	5	4	3	2	1	Bit 0
		Write:								
		Reset:	Indeterminate after reset							
\$0033 ↓ \$0035	Unimplemented	Read:								
		Write:								
		Reset:	0	0	0	0	0	0	0	0
\$0036	PLL Control Register (PCTL)	Read:	PLLIE	PLLF	PLLON	BCS	PRE1	PRE0	VPR1	VPR0
		Write:								
		Reset:	0	0	1	0	0	0	0	0
\$0037	PLL Bandwidth Control Register (PBWC)	Read:	AUTO	LOCK	$\overline{ACQ}$	0	0	0	0	R
		Write:								
		Reset:	0	0	0	0	0	0	0	0

= Unimplemented     
 R = Reserved     
 U = Unaffected

**Figure 2-2. Control, Status, and Data Registers (Sheet 5 of 7)**

## Memory Map

Addr.	Register Name	Bit 7	6	5	4	3	2	1	Bit 0		
\$0038	PLL Multiplier Select High Register (PMSH)	Read:	0	0	0	0	MUL11	MUL10	MUL9	MUL8	
		Write:									
		Reset:	0	0	0	0	0	0	0	0	
\$0039	PLL Multiplier Select Low Register (PMSL)	Read:	MUL7	MUL6	MUL5	MUL4	MUL3	MUL2	MUL1	MUL0	
		Write:									
		Reset:	0	1	0	0	0	0	0	0	
\$003A	PLL VCO Select Range Register (PMRS)	Read:	VRS7	VRS6	VRS5	VRS4	VRS3	VRS2	VRS1	VRS0	
		Write:									
		Reset:	0	1	0	0	0	0	0	0	
\$003B	PLL Reference Divider Select Register (PMDS)	Read:	0	0	0	0	RDS3	RDS2	RDS1	RDS0	
		Write:									
		Reset:	0	0	0	0	0	0	0	1	
\$003C	Analog-to-Digital Status and Control Register (ADSCR)	Read:	COCO	AIEN	ADCO	ADCH4	ADCH3	ADCH2	ADCH1	ADCH0	
		Write:	R								
		Reset:	0	0	0	1	1	1	1	1	
\$003D	Analog-to-Digital Data Register (ADR)	Read:	AD7	AD6	AD5	AD4	AD3	AD2	AD1	AD0	
		Write:									
		Reset:	Indeterminate after reset								
\$003E	Analog-to-Digital Input Clock Register (ADCLK)	Read:	ADIV2	ADIV1	ADIV0	ADICLK	0	0	0	0	
		Write:					R	R	R	R	
		Reset:	0	0	0	0	0	0	0	0	
\$003F	Unimplemented	Read:									
		Write:									
		Reset:									
\$FE00	SIM Break Status Register (SBSR)	Read:	R	R	R	R	R	R	BW	R	
		Write:								NOTE	
		Reset:	0	0	0	0	0	0	0	0	0
Note: Writing a logic 0 clears SBSW.											
\$FE01	SIM Reset Status Register (SRSR)	Read:	POR	PIN	COP	ILOP	ILAD	MODRST	LVI	0	
		Write:									
		POR:	1	0	0	0	0	0	0	0	
\$FE02	Unimplemented	Read:									
		Write:									
		Reset:									
\$FE03	SIM Break Flag Control Register (SBFCR)	Read:	BCFE	R	R	R	R	R	R	R	
		Write:									
		Reset:	0								

= Unimplemented      R = Reserved      U = Unaffected

**Figure 2-2. Control, Status, and Data Registers (Sheet 6 of 7)**

Addr.	Register Name	Bit 7	6	5	4	3	2	1	Bit 0	
\$FE04	Interrupt Status Register 1 (INT1)	Read:	IF6	IF5	IF4	IF3	IF2	IF1	0	0
		Write:	R	R	R	R	R	R	R	R
		Reset:	0	0	0	0	0	0	0	0
\$FE05	Interrupt Status Register 2 (INT2)	Read:	IF14	IF13	IF12	IF11	IF10	IF9	IF8	IF7
		Write:	R	R	R	R	R	R	R	R
		Reset:	0	0	0	0	0	0	0	0
\$FE06	Interrupt Status Register 3 (INT3)	Read:	0	0	0	0	0	0	IF16	IF15
		Write:	R	R	R	R	R	R	R	R
		Reset:	0	0	0	0	0	0	0	0
\$FE07	FLASH Test Control Register (FLTCR)	Read:	R	R	R	R	R	R	R	R
		Write:	R	R	R	R	R	R	R	R
		Reset:	0	0	0	0	0	0	0	0
\$FE08	FLASH Control Register (FLCR)	Read:	0	0	0	0	HVEN	MASS	ERASE	PGM
		Write:								
		Reset:	0	0	0	0	0	0	0	0
\$FE09	Break Address Register High (BRKH)	Read:	Bit 15	14	13	12	11	10	9	Bit 8
		Write:	Bit 15	14	13	12	11	10	9	Bit 8
		Reset:	0	0	0	0	0	0	0	0
\$FE0A	Break Address Register Low (BRKL)	Read:	Bit 7	6	5	4	3	2	1	Bit 0
		Write:	Bit 7	6	5	4	3	2	1	Bit 0
		Reset:	0	0	0	0	0	0	0	0
\$FE0B	Break Status and Control Register (BRKSCR)	Read:	BRKE	BRKA	0	0	0	0	0	0
		Write:	BRKE	BRKA						
		Reset:	0	0	0	0	0	0	0	0
\$FE0C	LVI Status Register (LVISR)	Read:	LVIOUT	0	0	0	0	0	0	0
		Write:								
		Reset:	0	0	0	0	0	0	0	0
\$FF7E	FLASH Block Protect Register (FLBPR) <sup>†</sup>	Read:	BPR7	BPR6	BPR5	BPR4	BPR3	BPR2	BPR1	BPR0
		Write:	BPR7	BPR6	BPR5	BPR4	BPR3	BPR2	BPR1	BPR0
		Reset:	U	U	U	U	U	U	U	U
\$FFFF	COP Control Register (COPCTL)	Read:	Low byte of reset vector							
		Write:	Writing clears COP counter (any value)							
		Reset:	Unaffected by reset							


<sup>†</sup> Non-volatile FLASH register

= Unimplemented      R = Reserved      U = Unaffected

**Figure 2-2. Control, Status, and Data Registers (Sheet 7 of 7)**

## 2.7 Vector Addresses

**Table 2-1. Vector Addresses**

Vector Priority	Vector	Address	Vector
Lowest  Highest	IF16	\$FFDC	Timebase Vector (High)
		\$FFDD	Timebase Vector (Low)
	IF15	\$FFDE	ADC Conversion Complete Vector (High)
		\$FFDF	ADC Conversion Complete Vector (Low)
	IF14	\$FFE0	Keyboard Vector (High)
		\$FFE1	Keyboard Vector (Low)
	IF13	\$FFE2	SCI Transmit Vector (High)
		\$FFE3	SCI Transmit Vector (Low)
	IF12	\$FFE4	SCI Receive Vector (High)
		\$FFE5	SCI Receive Vector (Low)
	IF11	\$FFE6	SCI Error Vector (High)
		\$FFE7	SCI Error Vector (Low)
	IF10	\$FFE8	SPI Transmit Vector (High)
		\$FFE9	SPI Transmit Vector (Low)
	IF9	\$FFEA	SPI Receive Vector (High)
		\$FFEB	SPI Receive Vector (Low)
	IF8	\$FFEC	TIM2 Overflow Vector (High)
		\$FFED	TIM2 Overflow Vector (Low)
	IF7	\$FFEE	Reserved
		\$FFEF	Reserved
	IF6	\$FFF0	TIM2 Channel 0 Vector (High)
		\$FFF1	TIM2 Channel 0 Vector (Low)
	IF5	\$FFF2	TIM1 Overflow Vector (High)
		\$FFF3	TIM1 Overflow Vector (Low)
	IF4	\$FFF4	TIM1 Channel 1 Vector (High)
		\$FFF5	TIM1 Channel 1 Vector (Low)
	IF3	\$FFF6	TIM1 Channel 0 Vector (High)
		\$FFF7	TIM1 Channel 0 Vector (Low)
	IF2	\$FFF8	PLL Vector (High)
		\$FFF9	PLL Vector (Low)
IF1	\$FFFA	$\overline{IRQ}$ Vector (High)	
	\$FFFB	$\overline{IRQ}$ Vector (Low)	
—	\$FFFC	SWI Vector (High)	
	\$FFFD	SWI Vector (Low)	
—	\$FFFE	Reset Vector (High)	
	\$FFFF	Reset Vector (Low)	

# Chapter 3

## Low-Power Modes

### 3.1 Introduction

The MCU may enter two low-power modes: wait mode and stop mode. They are common to all HC08 MCUs and are entered through instruction execution. This section describes how each module acts in the low-power modes.

#### 3.1.1 Wait Mode

The WAIT instruction puts the MCU in a low-power standby mode in which the CPU clock is disabled but the bus clock continues to run. Power consumption can be further reduced by disabling the LVI module and/or the timebase module through bits in the CONFIG register. (See [Chapter 8 Configuration Register \(CONFIG\)](#).)

#### 3.1.2 Stop Mode

Stop mode is entered when a STOP instruction is executed. The CPU clock is disabled and the bus clock is disabled if the OSCSTOPENB bit in the CONFIG register is at a logic 0. (See [Chapter 8 Configuration Register \(CONFIG\)](#).)

### 3.2 Analog-to-Digital Converter (ADC)

#### 3.2.1 Wait Mode

The ADC continues normal operation during wait mode. Any enabled CPU interrupt request from the ADC can bring the MCU out of wait mode. If the ADC is not required to bring the MCU out of wait mode, power down the ADC by setting ADCH4–ADCH0 bits in the ADC status and control register before executing the WAIT instruction.

#### 3.2.2 Stop Mode

The ADC module is inactive after the execution of a STOP instruction. Any pending conversion is aborted. ADC conversions resume when the MCU exits stop mode after an external interrupt. Allow one conversion cycle to stabilize the analog circuitry.

### 3.3 Break Module (BRK)

#### 3.3.1 Wait Mode

If enabled, the break module is active in wait mode. In the break routine, the user can subtract one from the return address on the stack if the BW bit in the break status register is set.

#### 3.3.2 Stop Mode

The break module is inactive in stop mode. The STOP instruction does not affect break module register states.

### 3.4 Central Processor Unit (CPU)

#### 3.4.1 Wait Mode

The WAIT instruction:

- Clears the interrupt mask (I bit) in the condition code register, enabling interrupts. After exit from wait mode by interrupt, the I bit remains clear. After exit by reset, the I bit is set.
- Disables the CPU clock

#### 3.4.2 Stop Mode

The STOP instruction:

- Clears the interrupt mask (I bit) in the condition code register, enabling external interrupts. After exit from stop mode by external interrupt, the I bit remains clear. After exit by reset, the I bit is set.
- Disables the CPU clock

After exiting stop mode, the CPU clock begins running after the oscillator stabilization delay.

### 3.5 Clock Generator Module (CGM)

#### 3.5.1 Wait Mode

The CGM remains active in wait mode. Before entering wait mode, software can disengage and turn off the PLL by clearing the BCS and PLLON bits in the PLL control register (PCTL). Less power-sensitive applications can disengage the PLL without turning it off. Applications that require the PLL to wake the MCU from wait mode also can deselect the PLL output without turning off the PLL.

#### 3.5.2 Stop Mode

If the OSCSTOPEN bit in the CONFIG register is cleared (default), then the STOP instruction disables the CGM (oscillator and phase-locked loop) and holds low all CGM outputs (CGMXCLK, CGMOUT, and CGMINT).

If the OSCSTOPEN bit in the CONFIG register is set, then the phase locked loop is shut off, but the oscillator will continue to operate in stop mode.

## 3.6 Computer Operating Properly Module (COP)

### 3.6.1 Wait Mode

The COP remains active in wait mode. To prevent a COP reset during wait mode, periodically clear the COP counter in a CPU interrupt routine.

### 3.6.2 Stop Mode

Stop mode turns off the COPCLK input to the COP and clears the SIM counter. Service the COP immediately before entering or after exiting stop mode to ensure a full COP timeout period after entering or exiting stop mode.

The STOP bit in the configuration register (CONFIG) enables the STOP instruction. To prevent inadvertently turning off the COP with a STOP instruction, disable the STOP instruction by clearing the STOP bit.

## 3.7 External Interrupt Module (IRQ)

### 3.7.1 Wait Mode

The IRQ module remains active in wait mode. Clearing the IMASK bit in the IRQ status and control register enables  $\overline{\text{IRQ}}$  CPU interrupt requests to bring the MCU out of wait mode.

### 3.7.2 Stop Mode

The IRQ module remains active in stop mode. Clearing the IMASK bit in the IRQ status and control register enables  $\overline{\text{IRQ}}$  CPU interrupt requests to bring the MCU out of stop mode.

## 3.8 Keyboard Interrupt Module (KBI)

### 3.8.1 Wait Mode

The keyboard module remains active in wait mode. Clearing the IMASKK bit in the keyboard status and control register enables keyboard interrupt requests to bring the MCU out of wait mode.

### 3.8.2 Stop Mode

The keyboard module remains active in stop mode. Clearing the IMASKK bit in the keyboard status and control register enables keyboard interrupt requests to bring the MCU out of stop mode.

## 3.9 Low-Voltage Inhibit Module (LVI)

### 3.9.1 Wait Mode

If enabled, the LVI module remains active in wait mode. If enabled to generate resets, the LVI module can generate a reset and bring the MCU out of wait mode.

### 3.9.2 Stop Mode

If enabled, the LVI module remains active in stop mode. If enabled to generate resets, the LVI module can generate a reset and bring the MCU out of stop mode.

## 3.10 Serial Communications Interface Module (SCI)

### 3.10.1 Wait Mode

The SCI module remains active in wait mode. Any enabled CPU interrupt request from the SCI module can bring the MCU out of wait mode.

If SCI module functions are not required during wait mode, reduce power consumption by disabling the module before executing the WAIT instruction.

### 3.10.2 Stop Mode

The SCI module is inactive in stop mode. The STOP instruction does not affect SCI register states. SCI module operation resumes after the MCU exits stop mode.

Because the internal clock is inactive during stop mode, entering stop mode during an SCI transmission or reception results in invalid data.

## 3.11 Serial Peripheral Interface Module (SPI)

### 3.11.1 Wait Mode

The SPI module remains active in wait mode. Any enabled CPU interrupt request from the SPI module can bring the MCU out of wait mode.

If SPI module functions are not required during wait mode, reduce power consumption by disabling the SPI module before executing the WAIT instruction.

### 3.11.2 Stop Mode

The SPI module is inactive in stop mode. The STOP instruction does not affect SPI register states. SPI operation resumes after an external interrupt. If stop mode is exited by reset, any transfer in progress is aborted, and the SPI is reset.

## 3.12 Timer Interface Module (TIM1 and TIM2)

### 3.12.1 Wait Mode

The TIM remains active in wait mode. Any enabled CPU interrupt request from the TIM can bring the MCU out of wait mode.

If TIM functions are not required during wait mode, reduce power consumption by stopping the TIM before executing the WAIT instruction.



### 3.12.2 Stop Mode

The TIM is inactive in stop mode. The STOP instruction does not affect register states or the state of the TIM counter. TIM operation resumes when the MCU exits stop mode after an external interrupt.

## 3.13 Timebase Module (TBM)

### 3.13.1 Wait Mode

The timebase module remains active after execution of the WAIT instruction. In wait mode, the timebase register is not accessible by the CPU.

If the timebase functions are not required during wait mode, reduce the power consumption by stopping the timebase before enabling the WAIT instruction.

### 3.13.2 Stop Mode

The timebase module may remain active after execution of the STOP instruction if the oscillator has been enabled to operate during stop mode through the OSCSTOPEN bit in the CONFIG register. The timebase module can be used in this mode to generate a periodic wakeup from stop mode.

If the oscillator has not been enabled to operate in stop mode, the timebase module will not be active during stop mode. In stop mode, the timebase register is not accessible by the CPU.

If the timebase functions are not required during stop mode, reduce the power consumption by stopping the timebase before enabling the STOP instruction.

## 3.14 Exiting Stop Mode

These events restart the system clocks and load the program counter with the reset vector or with an interrupt vector:

- External reset — A 0 on the  $\overline{\text{RST}}$  pin resets the MCU and loads the program counter with the contents of locations \$FFFE and \$FFFF.
- External interrupt — A high-to-low transition on an external interrupt pin loads the program counter with the contents of locations:
  - \$FFFA and \$FFFB;  $\overline{\text{IRQ}}$  pin
  - \$FFDE and \$FFDF; keyboard interrupt pins
- Low-voltage inhibit (LVI) reset — A power supply voltage below the  $\text{LVI}_{\text{tripf}}$  voltage resets the MCU and loads the program counter with the contents of locations \$FFFE and \$FFFF.
- Break interrupt — A break interrupt loads the program counter with the contents of locations \$FFFC and \$FFFD.
- Timebase module (TBM) interrupt — A TBM interrupt loads the program counter with the contents of locations \$FFDC and \$FFDD when the timebase counter has rolled over. This allows the TBM to generate a periodic wakeup from stop mode.

Upon exit from stop mode, the system clocks begin running after an oscillator stabilization delay. A 12-bit stop recovery counter inhibits the system clocks for 4096 CGMXCLK cycles after the reset or external interrupt.

## Low-Power Modes

The short stop recovery bit, SSREC, in the configuration register controls the oscillator stabilization delay during stop recovery. Setting SSREC reduces stop recovery time from 4096 CGMXCLK cycles to 32 CGMXCLK cycles.

### **NOTE**

*Use the full stop recovery time (SSREC = 0) in applications that use an external crystal.*

# Chapter 4

## Resets and Interrupts

### 4.1 Introduction

Resets and interrupts are responses to exceptional events during program execution. A reset re-initializes the MCU to its startup condition. An interrupt vectors the program counter to a service routine.

### 4.2 Resets

A reset immediately returns the MCU to a known startup condition and begins program execution from a user-defined memory location.

#### 4.2.1 Effects

A reset:

- Immediately stops the operation of the instruction being executed
- Initializes certain control and status bits
- Loads the program counter with a user-defined reset vector address from locations \$FFFE and \$FFFF, \$FEFE and \$FFFF in monitor mode
- Selects CGMXCLK divided by four as the bus clock

#### 4.2.2 External Reset

A logic 0 applied to the  $\overline{\text{RST}}$  pin for a time,  $t_{\text{IRL}}$ , generates an external reset. An external reset sets the PIN bit in the SIM reset status register.

#### 4.2.3 Internal Reset

Sources:

- Power-on reset (POR)
- Computer operating properly (COP)
- Low-power reset circuits
- Illegal opcode
- Illegal address

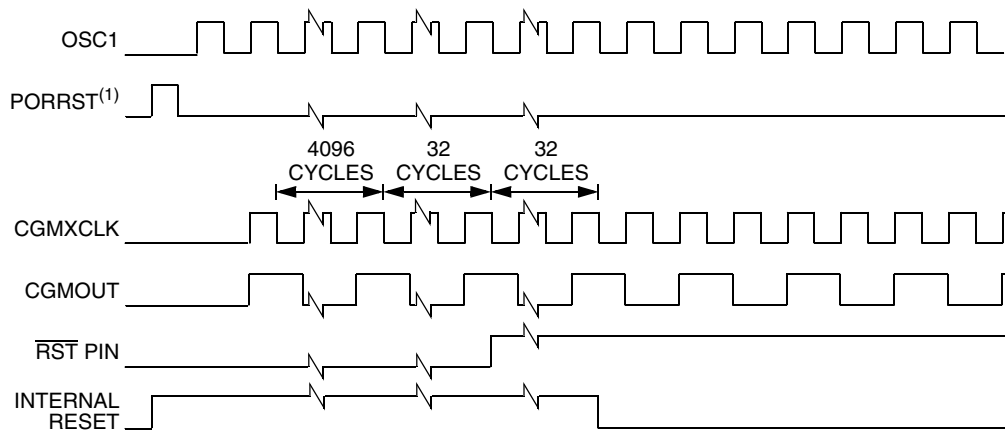
All internal reset sources pull the  $\overline{\text{RST}}$  pin low for 32 CGMXCLK cycles to allow resetting of external devices. The MCU is held in reset for an additional 32 CGMXCLK cycles after releasing the  $\overline{\text{RST}}$  pin.

### 4.2.3.1 Power-On Reset

A power-on reset is an internal reset caused by a positive transition on the  $V_{DD}$  pin.  $V_{DD}$  at the POR must go completely to 0 V to reset the MCU. This distinguishes between a reset and a POR. The POR is not a brown-out detector, low-voltage detector, or glitch detector.

A power-on reset:

- Holds the clocks to the CPU and modules inactive for an oscillator stabilization delay of 4096 CGMXCLK cycles
- Drives the  $\overline{RST}$  pin low during the oscillator stabilization delay
- Releases the RST pin 32 CGMXCLK cycles after the oscillator stabilization delay
- Releases the CPU to begin the reset vector sequence 64 CGMXCLK cycles after the oscillator stabilization delay
- Sets the POR bit in the SIM reset status register and clears all other bits in the register



1. PORRST is an internally generated power-on reset pulse.

**Figure 4-1. Power-On Reset Recovery**

### 4.2.3.2 COP Reset

A COP reset is an internal reset caused by an overflow of the COP counter. A COP reset sets the COP bit in the system integration module (SIM) reset status register.

To clear the COP counter and prevent a COP reset, write any value to the COP control register at location \$FFFF.

### 4.2.3.3 Low-Voltage Inhibit Reset

A low-voltage inhibit (LVI) reset is an internal reset caused by a drop in the power supply voltage to the LVI trip voltage,  $V_{TRIPF}$ .

An LVI reset:

- Holds the clocks to the CPU and modules inactive for an oscillator stabilization delay of 4096 CGMXCLK cycles after the power supply voltage rises to  $V_{TRIPF}$
- Drives the  $\overline{RST}$  pin low for as long as  $V_{DD}$  is below  $V_{TRIPF}$  and during the oscillator stabilization delay
- Releases the  $\overline{RST}$  pin 32 CGMXCLK cycles after the oscillator stabilization delay
- Releases the CPU to begin the reset vector sequence 64 CGMXCLK cycles after the oscillator stabilization delay
- Sets the LVI bit in the SIM reset status register

### 4.2.3.4 Illegal Opcode Reset

An illegal opcode reset is an internal reset caused by an opcode that is not in the instruction set. An illegal opcode reset sets the ILOP bit in the SIM reset status register.

If the stop enable bit, STOP, in the mask option register is a logic 0, the STOP instruction causes an illegal opcode reset.

### 4.2.3.5 Illegal Address Reset

An illegal address reset is an internal reset caused by opcode fetch from an unmapped address. An illegal address reset sets the ILAD bit in the SIM reset status register.

A data fetch from an unmapped address does not generate a reset.

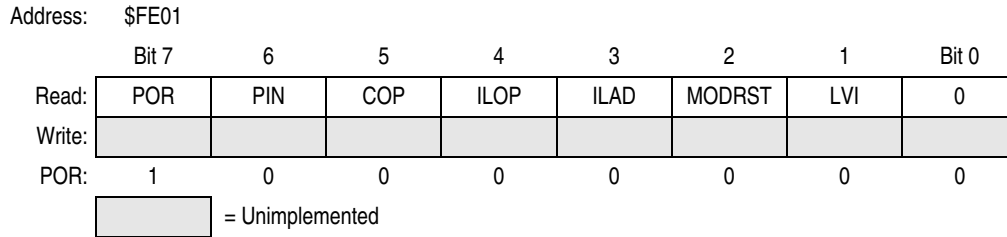
## 4.2.4 SIM Reset Status Register

This read-only register contains flags to show reset sources. All flag bits are automatically cleared following a read of the register. Reset service can read the SIM reset status register to clear the register after power-on reset and to determine the source of any subsequent reset.

The register is initialized on powerup as shown with the POR bit set and all other bits cleared. During a POR or any other internal reset, the  $\overline{RST}$  pin is pulled low. After the pin is released, it will be sampled 32 XCLK cycles later. If the pin is not above a  $V_{IH}$  at that time, then the PIN bit in the SRSR may be set in addition to whatever other bits are set.

#### **NOTE**

*Only a read of the SIM reset status register clears all reset flags. After multiple resets from different sources without reading the register, multiple flags remain set.*



**Figure 4-2. SIM Reset Status Register (SRSR)**

**POR — Power-On Reset Flag**

- 1 = Power-on reset since last read of SRSR
- 0 = Read of SRSR since last power-on reset

**PIN — External Reset Flag**

- 1 = External reset via  $\overline{RST}$  pin since last read of SRSR
- 0 = POR or read of SRSR since last external reset

**COP — Computer Operating Properly Reset Bit**

- 1 = Last reset caused by timeout of COP counter
- 0 = POR or read of SRSR

**ILOP — Illegal Opcode Reset Bit**

- 1 = Last reset caused by an illegal opcode
- 0 = POR or read of SRSR

**ILAD — Illegal Address Reset Bit**

- 1 = Last reset caused by an opcode fetch from an illegal address
- 0 = POR or read of SRSR

**MODRST — Monitor Mode Entry Module Reset Bit**

- 1 = Last reset caused by monitor mode entry when vector locations \$FFFE and \$FFFF are \$FF after POR while  $\overline{IRQ} = V_{DD}$
- 0 = POR or read of SRSR

**LVI — Low-Voltage Inhibit Reset Bit**

- 1 = Last reset caused by low-power supply voltage
- 0 = POR or read of SRSR

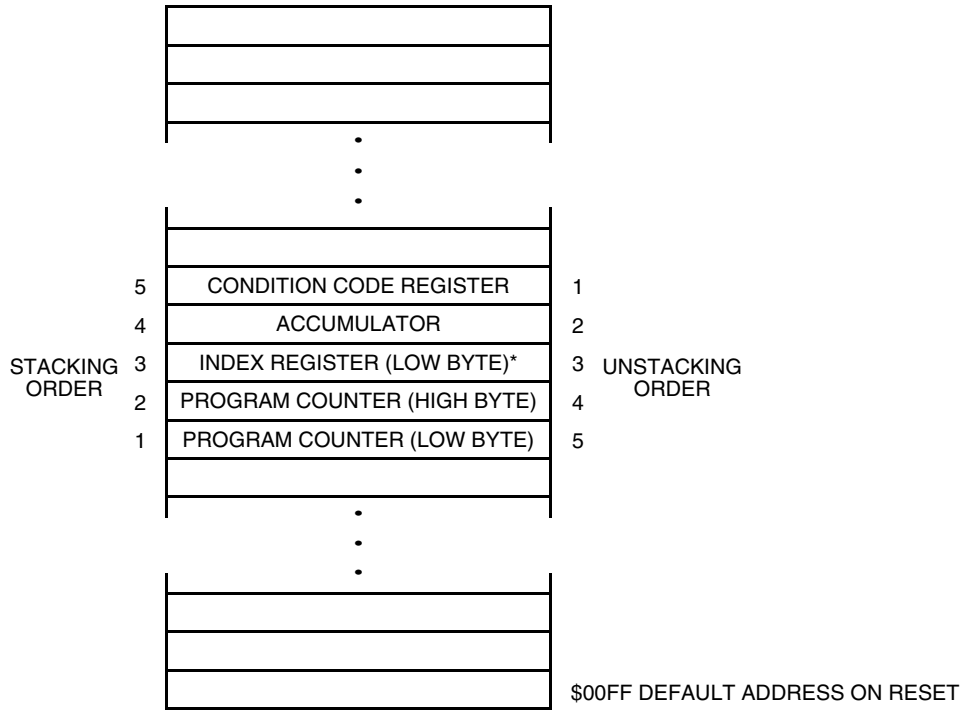
### 4.3 Interrupts

An interrupt temporarily changes the sequence of program execution to respond to a particular event. An interrupt does not stop the operation of the instruction being executed, but begins when the current instruction completes its operation.

### 4.3.1 Effects

An interrupt:

- Saves the CPU registers on the stack. At the end of the interrupt, the RTI instruction recovers the CPU registers from the stack so that normal processing can resume.
- Sets the interrupt mask (I bit) to prevent additional interrupts. Once an interrupt is latched, no other interrupt can take precedence, regardless of its priority.
- Loads the program counter with a user-defined vector address

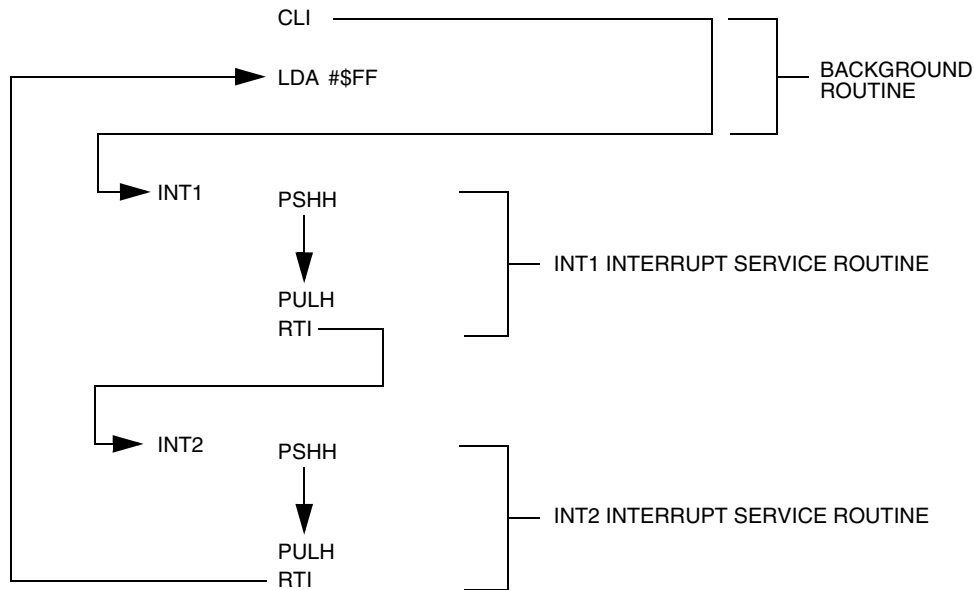


\*High byte of index register is not stacked.

**Figure 4-3. Interrupt Stacking Order**

## Resets and Interrupts

After every instruction, the CPU checks all pending interrupts if the I bit is not set. If more than one interrupt is pending when an instruction is done, the highest priority interrupt is serviced first. In the example shown in Figure 4-4, if an interrupt is pending upon exit from the interrupt service routine, the pending interrupt is serviced before the LDA instruction is executed.



**Figure 4-4. Interrupt Recognition Example**

The LDA opcode is prefetched by both the INT1 and INT2 RTI instructions. However, in the case of the INT1 RTI prefetch, this is a redundant operation.

### **NOTE**

*To maintain compatibility with the M6805 Family, the H register is not pushed on the stack during interrupt entry. If the interrupt service routine modifies the H register or uses the indexed addressing mode, save the H register and then restore it prior to exiting the routine.*



### 4.3.2 Sources

The sources in [Table 4-1](#) can generate CPU interrupt requests.

**Table 4-1. Interrupt Sources**

Source	Flag	Mask <sup>(1)</sup>	INT Register Flag	Priority <sup>(2)</sup>	Vector Address
Reset	None	None	None	0	\$FFFE–\$FFFF
SWI instruction	None	None	None	0	\$FFFC–\$FFFD
IRQ pin	IRQF	IMASK1	IF1	1	\$FFFA–\$FFFB
CGM (PLL)	PLLF	PLLIE	IF2	2	\$FFF8–\$FFF9
TIM1 channel 0	CH0F	CH0IE	IF3	3	\$FFF6–\$FFF7
TIM1 channel 1	CH1F	CH1IE	IF4	4	\$FFF4–\$FFF5
TIM1 overflow	TOF	TOIE	IF5	5	\$FFF2–\$FFF3
TIM2 channel 0	CH0F	CH0IE	IF6	6	\$FFF0–\$FFF1
TIM2 overflow	TOF	TOIE	IF8	8	\$FFEC–\$FFED
SPI receiver full	SPRF	SPRIE	IF9	9	\$FFEA–\$FFEB
SPI overflow	OVRF	ERRIE			
SPI mode fault	MODF	ERRIE			
SPI transmitter empty	SPTF	SPTIE	IF10	10	\$FFE8–\$FFE9
SCI receiver overrun	OR	ORIE	IF11	11	\$FFE6–\$FFE7
SCI noise flag	NF	NEIE			
SCI framing error	FE	FEIE			
SCI parity error	PE	PEIE			
SCI receiver full	SCRF	SCRIE	IF12	12	\$FFE4–\$FFE5
SCI input idle	IDLE	ILIE			
SCI transmitter empty	SCTE	SCTIE	IF13	13	\$FFE2–\$FFE3
SCI transmission complete	TC	TCIE			
Keyboard pin	KEYF	IMASKK	IF14	14	\$FFDE–\$FFDF
ADC conversion complete	COCO	AIEN	IF15	15	\$FFDE–\$FFDF
Timebase	TBIF	TBIE	IF16	16	\$FFDC–\$FFDD

1. The I bit in the condition code register is a global mask for all interrupt sources except the SWI instruction.

2. 0 = highest priority

4.3.2.1 SWI Instruction

The software interrupt instruction (SWI) causes a non-maskable interrupt.

**NOTE**

A software interrupt pushes PC onto the stack. An SWI does **not** push PC - 1, as a hardware interrupt does.

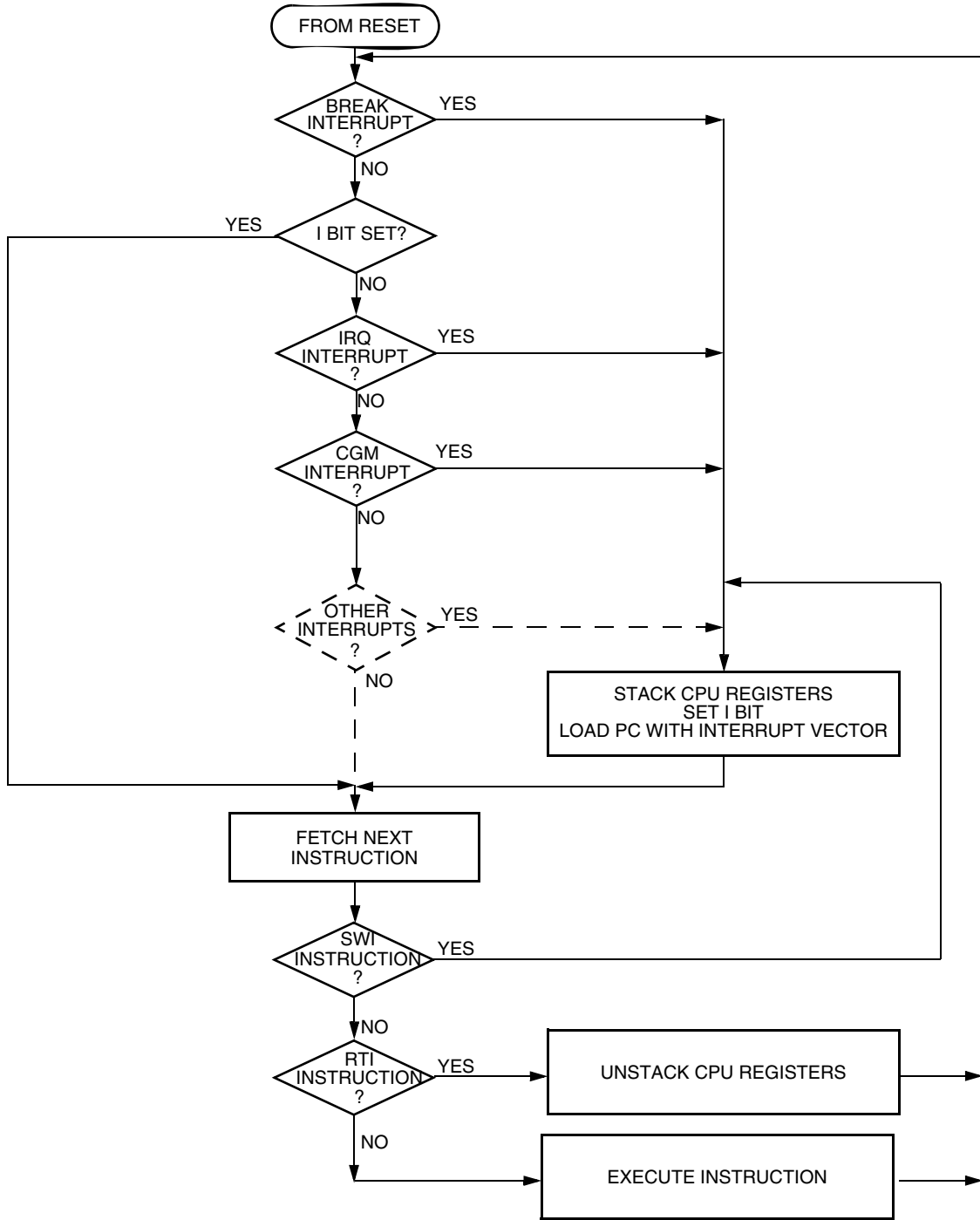


Figure 4-5. Interrupt Processing

### 4.3.2.2 Break Interrupt

The break module causes the CPU to execute an SWI instruction at a software-programmable break point.

### 4.3.2.3 $\overline{IRQ1}$ Pin

A logic 0 on the  $\overline{IRQ1}$  pin latches an external interrupt request.

### 4.3.2.4 CGM (Clock Generator Module)

The CGM can generate a CPU interrupt request every time the phase-locked loop circuit (PLL) enters or leaves the locked state. When the LOCK bit changes state, the PLL flag (PLLFL) is set. The PLL interrupt enable bit (PLLIE) enables PLLFL CPU interrupt requests. LOCK is in the PLL bandwidth control register. PLLFL is in the PLL control register.

### 4.3.2.5 TIM1 (Timer Interface Module 1)

TIM1 CPU interrupt sources:

- TIM1 overflow flag (TOF) — The TOF bit is set when the TIM1 counter value rolls over to \$0000 after matching the value in the TIM1 counter modulo registers. The TIM1 overflow interrupt enable bit, TOIE, enables TIM1 overflow CPU interrupt requests. TOF and TOIE are in the TIM1 status and control register.
- TIM1 channel flags (CH1F–CH0F) — The CHxF bit is set when an input capture or output compare occurs on channel x. The channel x interrupt enable bit, CHxIE, enables channel x TIM1 CPU interrupt requests. CHxF and CHxIE are in the TIM1 channel x status and control register.

### 4.3.2.6 TIM2 (Timer Interface Module 2)

TIM2 CPU interrupt sources:

- TIM2 overflow flag (TOF) — The TOF bit is set when the TIM2 counter value rolls over to \$0000 after matching the value in the TIM2 counter modulo registers. The TIM2 overflow interrupt enable bit, TOIE, enables TIM2 overflow CPU interrupt requests. TOF and TOIE are in the TIM2 status and control register.
- TIM2 channel flag (CH0F) — The CH0F bit is set when an input capture or output compare occurs on channel 0. The channel 0 interrupt enable bit, CH0IE, enables channel 0 TIM2 CPU interrupt requests. CH0F and CH0IE are in the TIM2 channel 0 status and control register.

### 4.3.2.7 SPI (Serial Peripheral Interface)

SPI CPU interrupt sources:

- SPI receiver full bit (SPRF) — The SPRF bit is set every time a byte transfers from the shift register to the receive data register. The SPI receiver interrupt enable bit, SPRIE, enables SPRF CPU interrupt requests. SPRF is in the SPI status and control register and SPRIE is in the SPI control register.
- SPI transmitter empty (SPTE) — The SPTE bit is set every time a byte transfers from the transmit data register to the shift register. The SPI transmit interrupt enable bit, SPTIE, enables SPTE CPU interrupt requests. SPTE is in the SPI status and control register and SPTIE is in the SPI control register.

## Resets and Interrupts

- Mode fault bit (MODF) — The MODF bit is set in a slave SPI if the  $\overline{SS}$  pin goes high during a transmission with the mode fault enable bit (MODFEN) set. In a master SPI, the MODF bit is set if the  $\overline{SS}$  pin goes low at any time with the MODFEN bit set. The error interrupt enable bit, ERRIE, enables MODF CPU interrupt requests. MODF, MODFEN, and ERRIE are in the SPI status and control register.
- Overflow bit (OVRF) — The OVRF bit is set if software does not read the byte in the receive data register before the next full byte enters the shift register. The error interrupt enable bit, ERRIE, enables OVRF CPU interrupt requests. OVRF and ERRIE are in the SPI status and control register.

### 4.3.2.8 SCI (Serial Communications Interface)

SCI CPU interrupt sources:

- SCI transmitter empty bit (SCTE) — SCTE is set when the SCI data register transfers a character to the transmit shift register. The SCI transmit interrupt enable bit, SCTIE, enables transmitter CPU interrupt requests. SCTE is in SCI status register 1. SCTIE is in SCI control register 2.
- Transmission complete bit (TC) — TC is set when the transmit shift register and the SCI data register are empty and no break or idle character has been generated. The transmission complete interrupt enable bit, TCIE, enables transmitter CPU interrupt requests. TC is in SCI status register 1. TCIE is in SCI control register 2.
- SCI receiver full bit (SCRF) — SCRF is set when the receive shift register transfers a character to the SCI data register. The SCI receive interrupt enable bit, SCRIE, enables receiver CPU interrupts. SCRF is in SCI status register 1. SCRIE is in SCI control register 2.
- Idle input bit (IDLE) — IDLE is set when 10 or 11 consecutive logic 1s shift in from the RxD pin. The idle line interrupt enable bit, ILIE, enables IDLE CPU interrupt requests. IDLE is in SCI status register 1. ILIE is in SCI control register 2.
- Receiver overrun bit (OR) — OR is set when the receive shift register shifts in a new character before the previous character was read from the SCI data register. The overrun interrupt enable bit, ORIE, enables OR to generate SCI error CPU interrupt requests. OR is in SCI status register 1. ORIE is in SCI control register 3.
- Noise flag (NF) — NF is set when the SCI detects noise on incoming data or break characters, including start, data, and stop bits. The noise error interrupt enable bit, NEIE, enables NF to generate SCI error CPU interrupt requests. NF is in SCI status register 1. NEIE is in SCI control register 3.
- Framing error bit (FE) — FE is set when a logic 0 occurs where the receiver expects a stop bit. The framing error interrupt enable bit, FEIE, enables FE to generate SCI error CPU interrupt requests. FE is in SCI status register 1. FEIE is in SCI control register 3.
- Parity error bit (PE) — PE is set when the SCI detects a parity error in incoming data. The parity error interrupt enable bit, PEIE, enables PE to generate SCI error CPU interrupt requests. PE is in SCI status register 1. PEIE is in SCI control register 3.

### 4.3.2.9 $\overline{KBD0}$ – $\overline{KBD4}$ Pins

A 0 on a keyboard interrupt pin latches an external interrupt request.

### 4.3.2.10 ADC (Analog-to-Digital Converter)

When the AIEN bit is set, the ADC module is capable of generating a CPU interrupt after each ADC conversion. The COCO/IDMAS bit is not used as a conversion complete flag when interrupts are enabled.

### 4.3.2.11 TBM (Timebase Module)

The timebase module can interrupt the CPU on a regular basis with a rate defined by TBR2–TBR0. When the timebase counter chain rolls over, the TBIF flag is set. If the TBIE bit is set, enabling the timebase interrupt, the counter chain overflow will generate a CPU interrupt request.

Interrupts must be acknowledged by writing a logic 1 to the TACK bit.

## 4.3.3 Interrupt Status Registers

The flags in the interrupt status registers identify maskable interrupt sources. [Table 4-2](#) summarizes the interrupt sources and the interrupt status register flags that they set. The interrupt status registers can be useful for debugging.

**Table 4-2. Interrupt Source Flags**

Interrupt Source	Interrupt Status Register Flag
Reset	—
SWI instruction	—
$\overline{IRQ}$ pin	IF1
CGM (PLL)	IF2
TIM1 channel 0	IF3
TIM1 channel 1	IF4
TIM1 overflow	IF5
TIM2 channel 0	IF6
Reserved	IF7
TIM2 overflow	IF8
SPI receive	IF9
SPI transmit	IF10
SCI error	IF11
SCI receive	IF12
SCI transmit	IF13
Keyboard	IF14
ADC conversion complete	IF15
Timebase	IF16

### 4.3.3.1 Interrupt Status Register 1

Address: \$FE04

	Bit 7	6	5	4	3	2	1	Bit 0
Read:	IF6	IF5	IF4	IF3	IF2	IF1	0	0
Write:	R	R	R	R	R	R	R	R
Reset:	0	0	0	0	0	0	0	0

R = Reserved

**Figure 4-6. Interrupt Status Register 1 (INT1)**

#### IF6–IF1 — Interrupt Flags 6–1

These flags indicate the presence of interrupt requests from the sources shown in [Table 4-2](#).

- 1 = Interrupt request present
- 0 = No interrupt request present

#### Bit 1 and Bit 0 — Always read 0

### 4.3.3.2 Interrupt Status Register 2

Address: \$FE05

	Bit 7	6	5	4	3	2	1	Bit 0
Read:	IF14	IF13	IF12	IF11	IF10	IF9	IF8	0
Write:	R	R	R	R	R	R	R	R
Reset:	0	0	0	0	0	0	0	0

R = Reserved

**Figure 4-7. Interrupt Status Register 2 (INT2)**

#### IF14–IF8 — Interrupt Flags 14–7

These flags indicate the presence of interrupt requests from the sources shown in [Table 4-2](#).

- 1 = Interrupt request present
- 0 = No interrupt request present

#### Bit 0 — Always reads 0

### 4.3.3.3 Interrupt Status Register 3

Address: \$FE06

	Bit 7	6	5	4	3	2	1	Bit 0
Read:	0	0	0	0	0	0	IF16	IF15
Write:	R	R	R	R	R	R	R	R
Reset:	0	0	0	0	0	0	0	0

R = Reserved

**Figure 4-8. Interrupt Status Register 3 (INT3)**

#### IF16–IF15 — Interrupt Flags 16–15

This flag indicates the presence of an interrupt request from the source shown in [Table 4-2](#).

- 1 = Interrupt request present
- 0 = No interrupt request present

#### Bits 7–2 — Always read 0

# Chapter 5

## Analog-to-Digital Converter (ADC)

### 5.1 Introduction

This section describes the 8-bit analog-to-digital converter (ADC).

For further information regarding analog-to-digital converters on Freescale microcontrollers, please consult the *HC08 ADC Reference Manual*, ADCRM/AD.

### 5.2 Features

Features of the ADC module include:

- Six channels with multiplexed input
- Linear successive approximation with monotonicity
- 8-bit resolution
- Single or continuous conversion
- Conversion complete flag or conversion complete interrupt
- Selectable ADC clock

### 5.3 Functional Description

The ADC provides six pins for sampling external sources at pins PTB5/ATD5–PTB0/ATD0. An analog multiplexer allows the single ADC converter to select one of six ADC channels as ADC voltage in ( $V_{ADIN}$ ).  $V_{ADIN}$  is converted by the successive approximation register-based analog-to-digital converter. When the conversion is completed, ADC places the result in the ADC data register and sets a flag or generates an interrupt. See [Figure 5-1](#).

#### 5.3.1 ADC Port I/O Pins

PTB5/ATD5–PTB0/ATD0 are general-purpose I/O (input/output) pins that share with the ADC channels. The channel select bits define which ADC channel/port pin will be used as the input signal. The ADC overrides the port I/O logic by forcing that pin as input to the ADC. The remaining ADC channels/port pins are controlled by the port I/O logic and can be used as general-purpose I/O. Writes to the port register or DDR will not have any affect on the port pin that is selected by the ADC. Read of a port pin in use by the ADC will return a 0 if the corresponding DDR bit is a 0. If the DDR bit is a 1, the value in the port data latch is read.

## Analog-to-Digital Converter (ADC)

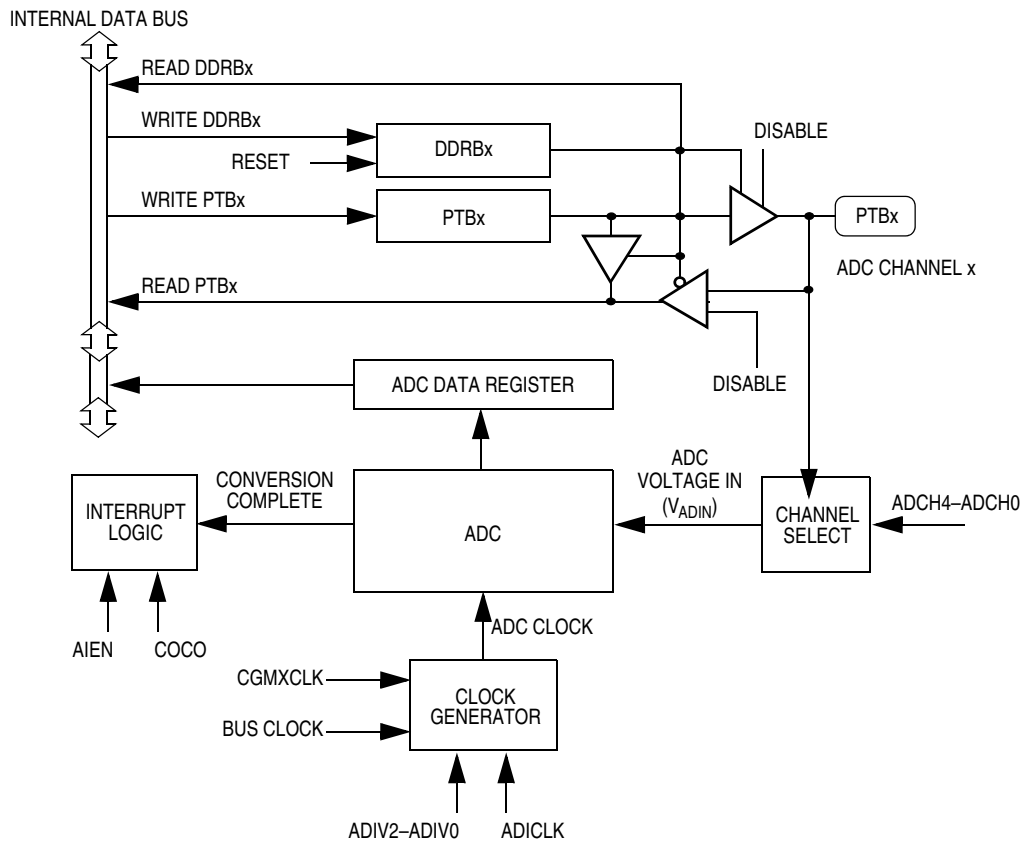


Figure 5-1. ADC Block Diagram

### 5.3.2 Voltage Conversion

When the input voltage to the ADC equals  $V_{REFH}$ , the ADC converts the signal to \$FFF (full scale). If the input voltage equals  $V_{REFL}$ , the ADC converts it to \$00. Input voltages between  $V_{REFH}$  and  $V_{REFL}$  are a straight-line linear conversion. All other input voltages will result in \$FFF, if greater than  $V_{REFH}$ .

#### NOTE

Inside the ADC module, the reference voltage,  $V_{REFH}$  is connected to the ADC analog power  $V_{DDAD}$ ; and  $V_{REFL}$  is connected to the ADC analog ground  $V_{DDAD}$ . Therefore, the ADC input voltage should not exceed the analog supply voltages

For operation,  $V_{DDAD}$  should be tied to the same potential as  $V_{DD}$  via separate traces

### 5.3.3 Conversion Time

Sixteen ADC internal clocks are required to perform one conversion. The ADC starts a conversion on the first rising edge of the ADC internal clock immediately following a write to the ADSCR. If the ADC internal clock is selected to run at 1 MHz, then one conversion will take 16  $\mu$ s to complete. But since the ADC can run almost completely asynchronously to the bus clock, (for example, the ADC is configured to derive its internal clock from CGMXCLK and the bus clock is being derived from the PLL within the CGM



[CGMOUT]), this 16- $\mu$ s conversion can take up to 17  $\mu$ s to complete. This worst-case could occur if the write to the ADSCR happened directly after the rising edge of the ADC internal clock causing the conversion to wait until the next rising edge of the ADC internal clock. With a 1-MHz ADC internal clock, the maximum sample rate is 59 kHz to 62 kHz. Refer to [23.12 ADC Characteristics](#).

$$\text{Conversion Time} = \frac{16 \text{ to } 17 \text{ ADC Clock Cycles}}{\text{ADC Clock Frequency}}$$

$$\text{Number of Bus Cycles} = \text{Conversion Time} \times \text{Bus Frequency}$$

### 5.3.4 Conversion

In continuous conversion mode, the ADC data register will be filled with new data after each conversion. Data from the previous conversion will be overwritten whether that data has been read or not. Conversions will continue until the ADCO bit is cleared. The COCO bit is set after the first conversion and will stay set until the next write of the ADC status and control register or the next read of the ADC data register.

In single conversion mode, conversion begins with a write to the ADSCR. Only one conversion occurs between writes to the ADSCR.

### 5.3.5 Accuracy and Precision

The conversion process is monotonic and has no missing codes. See [Chapter 23 Electrical Specifications](#) for accuracy information.

## 5.4 Interrupts

When the AIEN bit is set, the ADC module is capable of generating CPU interrupts after each ADC conversion. A CPU interrupt is generated if the COCO bit is at logic 0. The COCO bit is not used as a conversion complete flag when interrupts are enabled.

## 5.5 Low-Power Modes

The WAIT and STOP instruction can put the MCU in low power-consumption standby modes.

### 5.5.1 Wait Mode

The ADC continues normal operation during wait mode. Any enabled CPU interrupt request from the ADC can bring the MCU out of wait mode. If the ADC is not required to bring the MCU out of wait mode, power down the ADC by setting ADCH4–ADCH0 bits in the ADC status and control register before executing the WAIT instruction.

### 5.5.2 Stop Mode

The ADC module is inactive after the execution of a STOP instruction. Any pending conversion is aborted. ADC conversions resume when the MCU exits stop mode. Allow one conversion cycle to stabilize the analog circuitry before attempting a new ADC conversion after exiting stop mode.

## 5.6 I/O Signals

The ADC module has six pins shared with port B, PTB5/AD5–PTB0/ATD0.

### 5.6.1 ADC Analog Power Pin ( $V_{DDAD}$ )/ADC Voltage Reference High Pin ( $V_{REFH}$ )

The ADC analog portion uses  $V_{DDAD}$  as its power pin. Connect the  $V_{DDAD}$  pin to the same voltage potential as  $V_{DD}$ . External filtering may be necessary to ensure clean  $V_{DDAD}$  for good results.

**NOTE**

*For maximum noise immunity, route  $V_{DDAD}$  carefully and place bypass capacitors as close as possible to the package.*

### 5.6.2 ADC Analog Ground Pin ( $V_{SSAD}$ )/ADC Voltage Reference Low Pin ( $V_{REFL}$ )

The ADC analog portion uses  $V_{SSAD}$  as its ground pin. Connect the  $V_{SSAD}$  pin to the same voltage potential as  $V_{SS}$ .

### 5.6.3 ADC Voltage In ( $V_{ADIN}$ )

$V_{ADIN}$  is the input voltage signal from one of the six ADC channels to the ADC module.

## 5.7 I/O Registers

These I/O registers control and monitor ADC operation:

- ADC status and control register (ADSCR)
- ADC data register (ADR)
- ADC clock register (ADCLK)

### 5.7.1 ADC Status and Control Register

Function of the ADC status and control register (ADSCR) is described here.

Address:	\$0003C							
	Bit 7	6	5	4	3	2	1	Bit 0
Read:	COCO	AIEN	ADCO	ADCH4	ADCH3	ADCH2	ADCH1	ADCH0
Write:								
Reset:	0	0	0	1	1	1	1	1

**Figure 5-2. ADC Status and Control Register (ADSCR)**

#### COCO — Conversions Complete Bit

When the AIEN bit is a logic 0, the COCO is a read-only bit which is set each time a conversion is completed except in the continuous conversion mode where it is set after the first conversion. This bit is cleared whenever the ADSCR is written or whenever the ADR is read.

If the AIEN bit is a logic 1, the COCO is a read/write bit which selects the CPU to service the ADC interrupt request. Reset clears this bit.

1 = Conversion completed (AIEN = 0)

0 = Conversion not completed (AIEN = 0), or CPU interrupt (AIEN = 1)

**AIEN — ADC Interrupt Enable Bit**

When this bit is set, an interrupt is generated at the end of an ADC conversion. The interrupt signal is cleared when the data register is read or the status/control register is written. Reset clears the AIEN bit.

1 = ADC interrupt enabled

0 = ADC interrupt disabled

**ADCO — ADC Continuous Conversion Bit**

When this bit is set, the ADC will convert samples continuously and update the ADR register at the end of each conversion. Only one conversion is allowed when this bit is cleared. Reset clears the ADCO bit.

1 = Continuous ADC conversion

0 = One ADC conversion

**ADCH4–ADCH0 — ADC Channel Select Bits**

ADCH4–ADCH0 form a 5-bit field which is used to select one of 16 ADC channels. Only six channels, AD5–AD0, are available on this MCU. The channels are detailed in [Table 5-1](#). Care should be taken when using a port pin as both an analog and digital input simultaneously to prevent switching noise from corrupting the analog signal. See [Table 5-1](#).

The ADC subsystem is turned off when the channel select bits are all set to 1. This feature allows for reduced power consumption for the MCU when the ADC is not being used.

**NOTE**

*Recovery from the disabled state requires one conversion cycle to stabilize.*

The voltage levels supplied from internal reference nodes, as specified in [Table 5-1](#), are used to verify the operation of the ADC converter both in production test and for user applications.

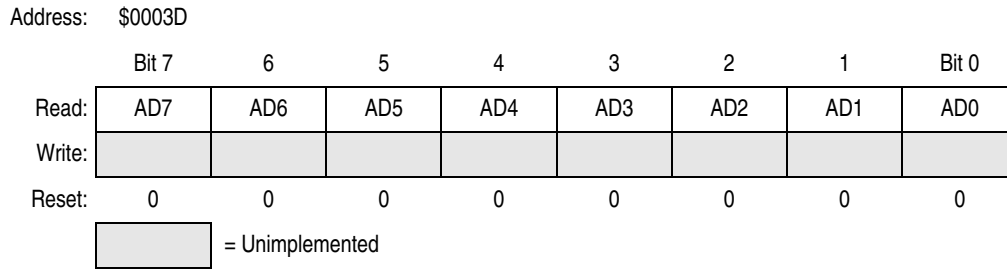
**Table 5-1. Mux Channel Select**

ADCH4	ADCH3	ADCH2	ADCH1	ADCH0	Input Select
0	0	0	0	0	PTB0/ATD0
0	0	0	0	1	PTB1/ATD1
0	0	0	1	0	PTB2/ATD2
0	0	0	1	1	PTB3/ATD3
0	0	1	0	0	PTB4/ATD4
0	0	1	0	1	PTB5/ATD5
0	0	1	1	0	Reserved
0	0	1	1	1	Reserved
↓	↓	↓	↓	↓	Reserved
1	1	0	1	1	Reserved
1	1	1	0	0	Reserved
1	1	1	0	1	V <sub>REFH</sub>
1	1	1	1	0	V <sub>REFL</sub>
1	1	1	1	1	ADC power off

NOTE: If an unknown channel is selected it should be made clear what value the user will read from the ADC Data Register, unknown or reserved is not specific enough.

### 5.7.2 ADC Data Register

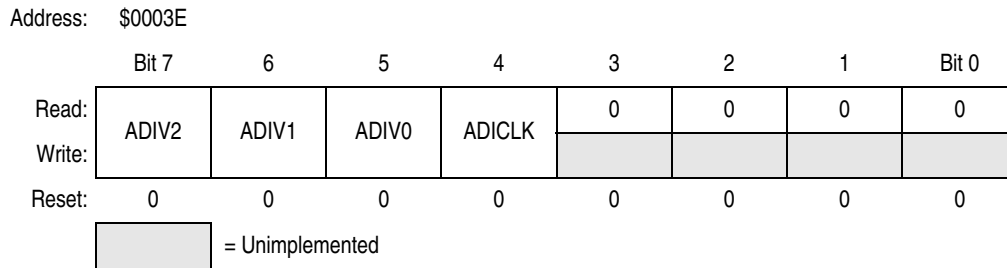
One 8-bit result register, ADC data register (ADR), is provided. This register is updated each time an ADC conversion completes.



**Figure 5-3. ADC Data Register (ADR)**

### 5.7.3 ADC Clock Register

The ADC clock register (ADCLK) selects the clock frequency for the ADC.



**Figure 5-4. ADC Clock Register (ADCLK)**

#### ADIV2–ADIV0 — ADC Clock Prescaler Bits

ADIV2–ADIV0 form a 3-bit field which selects the divide ratio used by the ADC to generate the internal ADC clock. Table 5-2 shows the available clock configurations. The ADC clock should be set to approximately 1 MHz.

**Table 5-2. ADC Clock Divide Ratio**

ADIV2	ADIV1	ADIV0	ADC Clock Rate
0	0	0	ADC input clock ÷ 1
0	0	1	ADC input clock ÷ 2
0	1	0	ADC input clock ÷ 4
0	1	1	ADC input clock ÷ 8
1	X	X	ADC input clock ÷ 16

X = don't care

**ADICLK — ADC Input Clock Select Bit**

ADICLK selects either the bus clock or CGMXCLK as the input clock source to generate the internal ADC clock. Reset selects CGMXCLK as the ADC clock source.

If the external clock (CGMXCLK) is equal to or greater than 1 MHz, CGMXCLK can be used as the clock source for the ADC. If CGMXCLK is less than 1 MHz, use the PLL-generated bus clock as the clock source. As long as the internal ADC clock is at approximately 1 MHz, correct operation can be guaranteed.

1 = Internal bus clock

0 = External clock (CGMXCLK)

$$\frac{\text{fxclk or bus frequency}}{\text{ADIV2-ADIV0}} = 1 \text{ MHz}$$

**NOTE**

*During the conversion process, changing the ADC clock will result in an incorrect conversion.*



# Chapter 6

## Break Module (BRK)

### 6.1 Introduction

This section describes the break module. The break module can generate a break interrupt that stops normal program flow at a defined address to enter a background program.

### 6.2 Features

Features of the break module include:

- Accessible input/output (I/O) registers during the break interrupt
- CPU-generated break interrupts
- Software-generated break interrupts
- COP disabling during break interrupts

### 6.3 Functional Description

When the internal address bus matches the value written in the break address registers, the break module issues a breakpoint signal to the SIM. The SIM then causes the CPU to load the instruction register with a software interrupt instruction (SWI). The program counter vectors to \$FFFC and \$FFFD (\$FEFC and \$FEFD in monitor mode).

The following events can cause a break interrupt to occur:

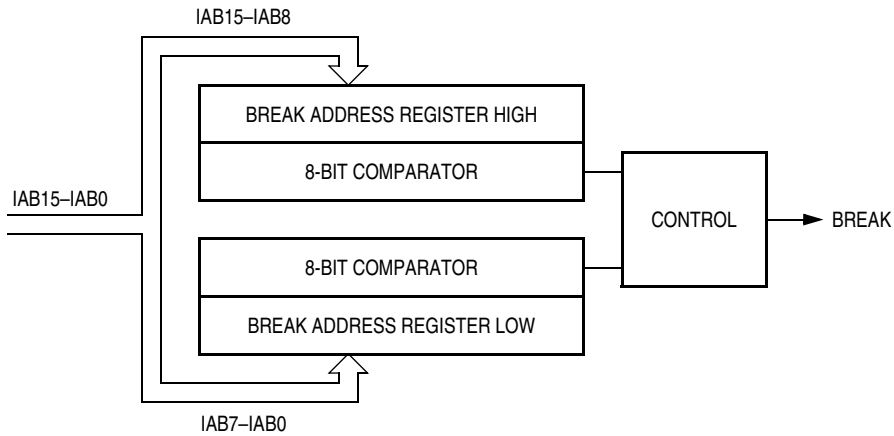
- A CPU-generated address (the address in the program counter) matches the contents of the break address registers.
- Software writes a logic 1 to the BRKA bit in the break status and control register.

When a CPU-generated address matches the contents of the break address registers, the break interrupt is generated. A return-from-interrupt instruction (RTI) in the break routine ends the break interrupt and returns the MCU to normal operation. [Figure 6-1](#) shows the structure of the break module.

#### 6.3.1 Flag Protection During Break Interrupts

The BCFE bit in the SIM break flag control register (SBFCR) enables software to clear status bits during the break state.

## Break Module (BRK)



**Figure 6-1. Break Module Block Diagram**

Addr.	Register Name	Bit 7	6	5	4	3	2	1	Bit 0	
\$FE00	SIM Break Status Register (SBSR)	Read:	0	0	0	1	0	0	BW	0
		Write:	R	R	R	R	R	R	NOTE	R
		Reset:	0	0	0	1	0	0	0	0
\$FE03	SIM Break Flag Control Register (SBFCR)	Read:								
		Write:	BCFE	R	R	R	R	R	R	R
		Reset:	0							
\$FE09	Break Address Register High (BRKH)	Read:	Bit 15	14	13	12	11	10	9	Bit 8
		Write:								
		Reset:	0	0	0	0	0	0	0	0
\$FE0A	Break Address Register Low (BRKL)	Read:	Bit 7	6	5	4	3	2	1	Bit 0
		Write:								
		Reset:	0	0	0	0	0	0	0	0
\$FE0B	Break Status and Control Register (BRKSCR)	Read:	BRKE	BRKA	0	0	0	0	0	0
		Write:								
		Reset:	0	0	0	0	0	0	0	0

Note: Writing a logic 0 clears BW.

= Unimplemented       = Reserved

**Figure 6-2. I/O Register Summary**

### 6.3.2 CPU During Break Interrupts

The CPU starts a break interrupt by:

- Loading the instruction register with the SWI instruction
- Loading the program counter with \$FFFC and \$FFFD (\$FEFC and \$FEFD in monitor mode)

The break interrupt begins after completion of the CPU instruction in progress. If the break address register match occurs on the last cycle of a CPU instruction, the break interrupt begins immediately.



### 6.3.3 TIM1 and TIM2 During Break Interrupts

A break interrupt stops the timer counters and inhibits input captures.

### 6.3.4 COP During Break Interrupts

The COP is disabled during a break interrupt when  $V_{TST}$  is present on the  $\overline{RST}$  pin.

## 6.4 Low-Power Modes

The WAIT and STOP instructions put the MCU in low power-consumption standby modes.

### 6.4.1 Wait Mode

If enabled, the break module is active in wait mode. In the break routine, the user can subtract one from the return address on the stack if SBSW is set. See [Chapter 3 Low-Power Modes](#). Clear the BW bit by writing logic 0 to it.

### 6.4.2 Stop Mode

A break interrupt causes exit from stop mode and sets the SBSW bit in the break status register.

## 6.5 Break Module Registers

These registers control and monitor operation of the break module:


- Break status and control register (BRKSCR)
- Break address register high (BRKH)
- Break address register low (BRKL)
- SIM break status register (SBSR)
- SIM break flag control register (SBFCR)

### 6.5.1 Break Status and Control Register

The break status and control register (BRKSCR) contains break module enable and status bits.

Address: \$FE0E

	Bit 7	6	5	4	3	2	1	Bit 0
Read:	BRKE	BRKA	0	0	0	0	0	0
Write:								
Reset:	0	0	0	0	0	0	0	0

 = Unimplemented

**Figure 6-3. Break Status and Control Register (BRKSCR)**

#### BRKE — Break Enable Bit

This read/write bit enables breaks on break address register matches. Clear BRKE by writing a logic 0 to bit 7. Reset clears the BRKE bit.

- 1 = Breaks enabled on 16-bit address match
- 0 = Breaks disabled on 16-bit address match

## Break Module (BRK)

### BRKA — Break Active Bit

This read/write status and control bit is set when a break address match occurs. Writing a logic 1 to BRKA generates a break interrupt. Clear BRKA by writing a logic 0 to it before exiting the break routine. Reset clears the BRKA bit.

- 1 = (When read) Break address match
- 0 = (When read) No break address match

### 6.5.2 Break Address Registers

The break address registers (BRKH and BRKL) contain the high and low bytes of the desired breakpoint address. Reset clears the break address registers.

Address: \$FE09

	Bit 7	6	5	4	3	2	1	Bit 0
Read:	Bit 15	14	13	12	11	10	9	Bit 8
Write:								
Reset:	0	0	0	0	0	0	0	0

**Figure 6-4. Break Address Register High (BRKH)**

Address: \$FE0A

	Bit 7	6	5	4	3	2	1	Bit 0
Read:	Bit 7	6	5	4	3	2	1	Bit 0
Write:								
Reset:	0	0	0	0	0	0	0	0

**Figure 6-5. Break Address Register Low (BRKL)**

### 6.5.3 Break Status Register

The break status register (SBSR) contains a flag to indicate that a break caused an exit from wait mode. The flag is useful in applications requiring a return to wait mode after exiting from a break interrupt.

Address: \$FE00

	Bit 7	6	5	4	3	2	1	Bit 0
Read:	0	0	0	1	0	0	BW	0
Write:	R	R	R	R	R	R	NOTE	R
Reset:	0	0	0	1	0	0	0	0

Note: Writing a logic 0 clears BW. 

R
---

 = Reserved

**Figure 6-6. SIM Break Status Register (SBSR)**

### BW — Break Wait Bit

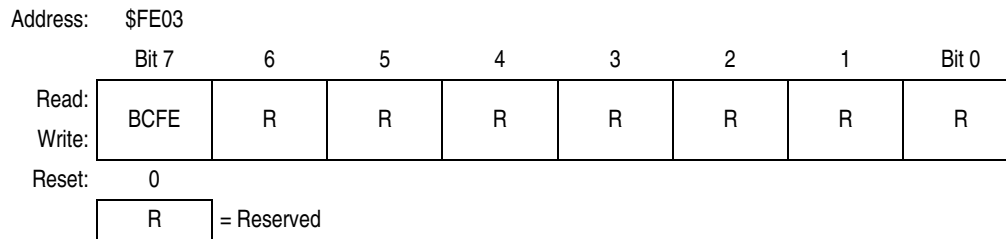
This read/write bit is set when a break interrupt causes an exit from wait mode. Clear BW by writing a logic 0 to it. Reset clears BW.

- 1 = Break interrupt during wait mode
- 0 = No break interrupt during wait mode

BW can be read within the break interrupt routine. The user can modify the return address on the stack by subtracting 1 from it.

### 6.5.4 Break Flag Control Register

The break flag control register (SBFCR) contains a bit that enables software to clear status bits while the MCU is in a break state.



**Figure 6-7. SIM Break Flag Control Register (SBFCR)**

#### BCFE — Break Clear Flag Enable Bit

This read/write bit enables software to clear status bits by accessing status registers while the MCU is in a break state. To clear status bits during the break state, the BCFE bit must be set.

- 1 = Status bits clearable during break
- 0 = Status bits not clearable during break



# Chapter 7

## Clock Generator Module (CGMC)

### 7.1 Introduction

This section describes the clock generator module. The CGMC generates the crystal clock signal, CGMXCLK, which operates at the frequency of the crystal. The CGMC also generates the base clock signal, CGMOUT, which is based on either the crystal clock divided by two or the phase-locked loop (PLL) clock, CGMVCLK, divided by two. In user mode, CGMOUT is the clock from which the SIM derives the system clocks, including the bus clock, which is at a frequency of CGMOUT/2. In monitor mode, PTC3 determines the bus clock. The PLL is a fully functional frequency generator designed for use with crystals or ceramic resonators. The PLL can generate an 8-MHz bus frequency using a 32-kHz crystal.

### 7.2 Features

Features of the CGMC include:

- Phase-locked loop with output frequency in integer multiples of an integer dividend of the crystal reference
- Low-frequency crystal operation with low-power operation and high-output frequency resolution
- Programmable prescaler for power-of-two increases in frequency
- Programmable hardware voltage-controlled oscillator (VCO) for low-jitter operation
- Automatic bandwidth control mode for low-jitter operation
- Automatic frequency lock detector
- CPU interrupt on entry or exit from locked condition
- Configuration register bit to allow oscillator operation during stop mode

### 7.3 Functional Description

The CGMC consists of three major submodules:

- Crystal oscillator circuit — The crystal oscillator circuit generates the constant crystal frequency clock, CGMXCLK.
- Phase-locked loop (PLL) — The PLL generates the programmable VCO frequency clock, CGMVCLK.
- Base clock selector circuit — This software-controlled circuit selects either CGMXCLK divided by two or the VCO clock, CGMVCLK, divided by two as the base clock, CGMOUT. The SIM derives the system clocks from either CGMOUT or CGMXCLK.

Figure 7-1 shows the structure of the CGMC.

## Clock Generator Module (CGMC)

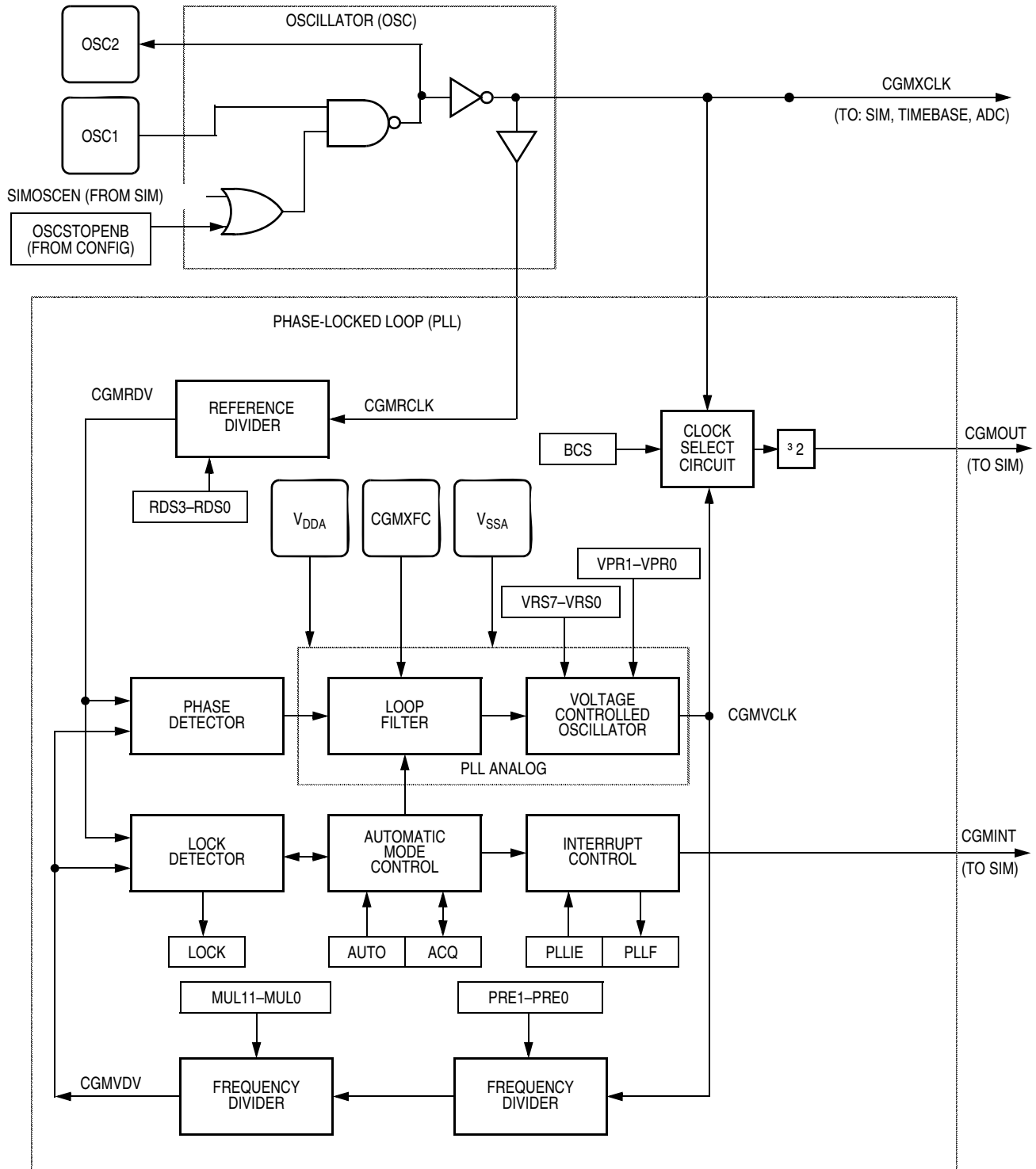


Figure 7-1. CGMC Block Diagram

### 7.3.1 Crystal Oscillator Circuit

The crystal oscillator circuit consists of an inverting amplifier and an external crystal. The OSC1 pin is the input to the amplifier and the OSC2 pin is the output. The SIMOSCEN signal from the system integration module (SIM) or the OSCSTOPENB bit in the CONFIG register enable the crystal oscillator circuit.

The CGMXCLK signal is the output of the crystal oscillator circuit and runs at a rate equal to the crystal frequency. CGMXCLK is then buffered to produce CGMRCLK, the PLL reference clock.

CGMXCLK can be used by other modules which require precise timing for operation. The duty cycle of CGMXCLK is not guaranteed to be 50% and depends on external factors, including the crystal and related external components. An externally generated clock also can feed the OSC1 pin of the crystal oscillator circuit. Connect the external clock to the OSC1 pin and let the OSC2 pin float.

### 7.3.2 Phase-Locked Loop Circuit (PLL)

The PLL is a frequency generator that can operate in either acquisition mode or tracking mode, depending on the accuracy of the output frequency. The PLL can change between acquisition and tracking modes either automatically or manually.

### 7.3.3 PLL Circuits

The PLL consists of these circuits:

- Voltage-controlled oscillator (VCO)
- Reference divider
- Frequency prescaler
- Modulo VCO frequency divider
- Phase detector
- Loop filter
- Lock detector

The operating range of the VCO is programmable for a wide range of frequencies and for maximum immunity to external noise, including supply and CGM/XFC noise. The VCO frequency is bound to a range from roughly one-half to twice the center-of-range frequency,  $f_{VRS}$ . Modulating the voltage on the CGM/XFC pin changes the frequency within this range. By design,  $f_{VRS}$  is equal to the nominal center-of-range frequency,  $f_{NOM}$ , (38.4 kHz) times a linear factor, L, and a power-of-two factor, E, or  $(L \times 2^E)f_{NOM}$ .

CGMRCLK is the PLL reference clock, a buffered version of CGMXCLK. CGMRCLK runs at a frequency,  $f_{RCLK}$ , and is fed to the PLL through a programmable modulo reference divider, which divides  $f_{RCLK}$  by a factor, R. The divider's output is the final reference clock, CGMRDV, running at a frequency,  $f_{RDV} = f_{RCLK}/R$ . With an external crystal (30 kHz–100 kHz), always set  $R = 1$  for specified performance. With an external high-frequency clock source, use R to divide the external frequency to between 30 kHz and 100 kHz.

The VCO's output clock, CGMVCLK, running at a frequency,  $f_{VCLK}$ , is fed back through a programmable prescale divider and a programmable modulo divider. The prescaler divides the VCO clock by a power-of-two factor P and the modulo divider reduces the VCO clock by a factor, N. The dividers' output is the VCO feedback clock, CGMVDV, running at a frequency,  $f_{VDV} = f_{VCLK}/(N \times 2^P)$ . (See [7.3.6 Programming the PLL](#) for more information.)

The phase detector then compares the VCO feedback clock, CGMVDV, with the final reference clock, CGMRDV. A correction pulse is generated based on the phase difference between the two signals. The loop filter then slightly alters the DC voltage on the external capacitor connected to CGM/XFC based on the width and direction of the correction pulse. The filter can make fast or slow corrections depending on its mode, described in [7.3.4 Acquisition and Tracking Modes](#). The value of the external capacitor and the reference frequency determine the speed of the corrections and the stability of the PLL.

The lock detector compares the frequencies of the VCO feedback clock, CGMVDV, and the final reference clock, CGMRDV. Therefore, the speed of the lock detector is directly proportional to the final reference frequency,  $f_{RDV}$ . The circuit determines the mode of the PLL and the lock condition based on this comparison.

### 7.3.4 Acquisition and Tracking Modes

The PLL filter is manually or automatically configurable into one of two operating modes:

- Acquisition mode — In acquisition mode, the filter can make large frequency corrections to the VCO. This mode is used at PLL startup or when the PLL has suffered a severe noise hit and the VCO frequency is far off the desired frequency. When in acquisition mode, the  $\overline{ACQ}$  bit is clear in the PLL bandwidth control register. (See [7.5.2 PLL Bandwidth Control Register](#).)
- Tracking mode — In tracking mode, the filter makes only small corrections to the frequency of the VCO. PLL jitter is much lower in tracking mode, but the response to noise is also slower. The PLL enters tracking mode when the VCO frequency is nearly correct, such as when the PLL is selected as the base clock source. (See [7.3.8 Base Clock Selector Circuit](#).) The PLL is automatically in tracking mode when not in acquisition mode or when the  $\overline{ACQ}$  bit is set.

### 7.3.5 Manual and Automatic PLL Bandwidth Modes

The PLL can change the bandwidth or operational mode of the loop filter manually or automatically. Automatic mode is recommended for most users.

In automatic bandwidth control mode ( $AUTO = 1$ ), the lock detector automatically switches between acquisition and tracking modes. Automatic bandwidth control mode also is used to determine when the VCO clock, CGMVCLK, is safe to use as the source for the base clock, CGMOUT. (See [7.5.2 PLL Bandwidth Control Register](#).) If PLL interrupts are enabled, the software can wait for a PLL interrupt request and then check the LOCK bit. If interrupts are disabled, software can poll the LOCK bit continuously (during PLL startup, usually) or at periodic intervals. In either case, when the LOCK bit is set, the VCO clock is safe to use as the source for the base clock. (See [7.3.8 Base Clock Selector Circuit](#).) If the VCO is selected as the source for the base clock and the LOCK bit is clear, the PLL has suffered a severe noise hit and the software must take appropriate action, depending on the application. (See [Interrupts](#) for information and precautions on using interrupts.)

The following conditions apply when the PLL is in automatic bandwidth control mode:

- The  $\overline{ACQ}$  bit (see [7.5.2 PLL Bandwidth Control Register](#)) is a read-only indicator of the mode of the filter. (See [7.3.4 Acquisition and Tracking Modes](#).)
- The  $\overline{ACQ}$  bit is set when the VCO frequency is within a certain tolerance and is cleared when the VCO frequency is out of a certain tolerance. (See [7.8 Acquisition/Lock Time Specifications](#) for more information.)
- The LOCK bit is a read-only indicator of the locked state of the PLL.



- The LOCK bit is set when the VCO frequency is within a certain tolerance and is cleared when the VCO frequency is out of a certain tolerance. (See [7.8 Acquisition/Lock Time Specifications](#) for more information.)
- CPU interrupts can occur if enabled (PLLIE = 1) when the PLL's lock condition changes, toggling the LOCK bit. (See [7.5.1 PLL Control Register](#).)

The PLL also may operate in manual mode (AUTO = 0). Manual mode is used by systems that do not require an indicator of the lock condition for proper operation. Such systems typically operate well below  $f_{\text{BUSMAX}}$ .

The following conditions apply when in manual mode:

- $\overline{\text{ACQ}}$  is a writable control bit that controls the mode of the filter. Before turning on the PLL in manual mode, the  $\overline{\text{ACQ}}$  bit must be clear.
- Before entering tracking mode ( $\overline{\text{ACQ}} = 1$ ), software must wait a given time,  $t_{\text{ACQ}}$  (see [7.8 Acquisition/Lock Time Specifications](#)), after turning on the PLL by setting PLLON in the PLL control register (PCTL).
- Software must wait a given time,  $t_{\text{AL}}$ , after entering tracking mode before selecting the PLL as the clock source to CGMOUT (BCS = 1).
- The LOCK bit is disabled.
- CPU interrupts from the CGMC are disabled.

### 7.3.6 Programming the PLL

The following procedure shows how to program the PLL.

#### NOTE

*The round function in the following equations means that the real number should be rounded to the nearest integer number.*

1. Choose the desired bus frequency,  $f_{\text{BUSDES}}$ .
2. Calculate the desired VCO frequency (four times the desired bus frequency).

$$f_{\text{VCLKDES}} = 4 \times f_{\text{BUSDES}}$$

3. Choose a practical PLL (crystal) reference frequency,  $f_{\text{RCLK}}$ , and the reference clock divider, R. Typically, the reference crystal is 32.768 kHz and R = 1.

Frequency errors to the PLL are corrected at a rate of  $f_{\text{RCLK}}/R$ . For stability and lock time reduction, this rate must be as fast as possible. The VCO frequency must be an integer multiple of this rate. The relationship between the VCO frequency,  $f_{\text{VCLK}}$ , and the reference frequency,  $f_{\text{RCLK}}$ , is

$$f_{\text{VCLK}} = \frac{2^P N}{R} (f_{\text{RCLK}})$$

P, the power of two multiplier, and N, the range multiplier, are integers.

In cases where desired bus frequency has some tolerance, choose  $f_{\text{RCLK}}$  to a value determined either by other module requirements (such as modules which are clocked by CGMXCLK), cost requirements, or ideally, as high as the specified range allows. See [Chapter 23 Electrical Specifications](#). Choose the reference divider, R = 1. After choosing N and P, the actual bus frequency can be determined using equation in 2 above.

When the tolerance on the bus frequency is tight, choose  $f_{RCLK}$  to an integer divisor of  $f_{BUSDES}$ , and  $R = 1$ . If  $f_{RCLK}$  cannot meet this requirement, use the following equation to solve for  $R$  with practical choices of  $f_{RCLK}$ , and choose the  $f_{RCLK}$  that gives the lowest  $R$ .

$$R = \text{round} \left[ R_{\text{MAX}} \times \left\{ \left( \frac{f_{\text{VCLKDES}}}{f_{\text{RCLK}}} \right) - \text{integer} \left( \frac{f_{\text{VCLKDES}}}{f_{\text{RCLK}}} \right) \right\} \right]$$

4. Select a VCO frequency multiplier,  $N$ .

$$N = \text{round} \left( \frac{R \times f_{\text{VCLKDES}}}{f_{\text{RCLK}}} \right)$$

Reduce  $N/R$  to the lowest possible  $R$ .

5. If  $N < N_{\text{max}}$ , use  $P = 0$ . If  $N > N_{\text{max}}$ , choose  $P$  using this table:

Current N Value	P
$0 < N \leq N_{\text{max}}$	0
$N_{\text{max}} < N \leq N_{\text{max}} \times 2$	1
$N_{\text{max}} \times 2 < N \leq N_{\text{max}} \times 4$	2
$N_{\text{max}} \times 4 < N \leq N_{\text{max}} \times 8$	3

Then recalculate  $N$ :

$$N = \text{round} \left( \frac{R \times f_{\text{VCLKDES}}}{f_{\text{RCLK}} \times 2^P} \right)$$

6. Calculate and verify the adequacy of the VCO and bus frequencies  $f_{\text{VCLK}}$  and  $f_{\text{BUS}}$ .

$$f_{\text{VCLK}} = (2^P \times N/R) \times f_{\text{RCLK}}$$

$$f_{\text{BUS}} = (f_{\text{VCLK}})/4$$

7. Select the VCO's power-of-two range multiplier  $E$ , according to this table:

Frequency Range	E
$0 < f_{\text{VCLK}} < 8 \text{ MHz}$	0
$9,830,400 \leq f_{\text{VCLK}} < 16 \text{ MHz}$	1
$19,660,800 \leq f_{\text{VCLK}} < 32 \text{ MHz}$	2

NOTE: Do not program  $E$  to a value of 3.

8. Select a VCO linear range multiplier,  $L$ , where  $f_{\text{NOM}} = 38.4 \text{ kHz}$

$$L = \text{round} \left( \frac{f_{\text{VCLK}}}{2^E \times f_{\text{NOM}}} \right)$$

9. Calculate and verify the adequacy of the VCO programmed center-of-range frequency,  $f_{VRS}$ . The center-of-range frequency is the midpoint between the minimum and maximum frequencies attainable by the PLL.

$$f_{VRS} = (L \times 2^E) f_{NOM}$$

For proper operation,

$$|f_{VRS} - f_{VCLK}| \leq \frac{f_{NOM} \times 2^E}{2}$$

10. Verify the choice of P, R, N, E, and L by comparing  $f_{VCLK}$  to  $f_{VRS}$  and  $f_{VCLKDES}$ . For proper operation,  $f_{VCLK}$  must be within the application's tolerance of  $f_{VCLKDES}$ , and  $f_{VRS}$  must be as close as possible to  $f_{VCLK}$ .

**NOTE**

*Exceeding the recommended maximum bus frequency or VCO frequency can crash the MCU.*

11. Program the PLL registers accordingly:
- In the PRE bits of the PLL control register (PCTL), program the binary equivalent of P.
  - In the VPR bits of the PLL control register (PCTL), program the binary equivalent of E.
  - In the PLL multiplier select register low (PMSL) and the PLL multiplier select register high (PMSH), program the binary equivalent of N.
  - In the PLL VCO range select register (PMRS), program the binary coded equivalent of L.
  - In the PLL reference divider select register (PMDS), program the binary coded equivalent of R.

Table 7-1 provides numeric examples (numbers are in hexadecimal notation):

**Table 7-1. Numeric Example**

$f_{BUS}$	$f_{RCLK}$	R	N	P	E	L
2.0 MHz	32.768 kHz	1	F5	0	0	D1
2.4576 MHz	32.768 kHz	1	12C	0	1	80
2.5 MHz	32.768 kHz	1	132	0	1	83
4.0 MHz	32.768 kHz	1	1E9	0	1	D1
4.9152 MHz	32.768 kHz	1	258	0	2	80
5.0 MHz	32.768 kHz	1	263	0	2	82
7.3728 MHz	32.768 kHz	1	384	0	2	C0
8.0 MHz	32.768 kHz	1	3D1	0	2	D0

### 7.3.7 Special Programming Exceptions

The programming method described in [7.3.6 Programming the PLL](#) does not account for three possible exceptions. A value of 0 for R, N, or L is meaningless when used in the equations given. To account for these exceptions:

- A 0 value for R or N is interpreted exactly the same as a value of 1.
- A 0 value for L disables the PLL and prevents its selection as the source for the base clock.

(See [7.3.8 Base Clock Selector Circuit](#).)

### 7.3.8 Base Clock Selector Circuit

This circuit is used to select either the crystal clock, CGMXCLK, or the VCO clock, CGMVCLK, as the source of the base clock, CGMOUT. The two input clocks go through a transition control circuit that waits up to three CGMXCLK cycles and three CGMVCLK cycles to change from one clock source to the other. During this time, CGMOUT is held in stasis. The output of the transition control circuit is then divided by two to correct the duty cycle. Therefore, the bus clock frequency, which is one-half of the base clock frequency, is one-fourth the frequency of the selected clock (CGMXCLK or CGMVCLK).

The BCS bit in the PLL control register (PCTL) selects which clock drives CGMOUT. The VCO clock cannot be selected as the base clock source if the PLL is not turned on. The PLL cannot be turned off if the VCO clock is selected. The PLL cannot be turned on or off simultaneously with the selection or deselection of the VCO clock. The VCO clock also cannot be selected as the base clock source if the factor L is programmed to a 0. This value would set up a condition inconsistent with the operation of the PLL, so that the PLL would be disabled and the crystal clock would be forced as the source of the base clock.

### 7.3.9 CGMC External Connections

In its typical configuration, the CGMC requires up to nine external components. Five of these are for the crystal oscillator and two or four are for the PLL.

The crystal oscillator is normally connected in a Pierce oscillator configuration, as shown in [Figure 7-2](#). [Figure 7-2](#) shows only the logical representation of the internal components and may not represent actual circuitry. The oscillator configuration uses five components:

- Crystal,  $X_1$
- Fixed capacitor,  $C_1$
- Tuning capacitor,  $C_2$  (can also be a fixed capacitor)
- Feedback resistor,  $R_B$
- Series resistor,  $R_S$

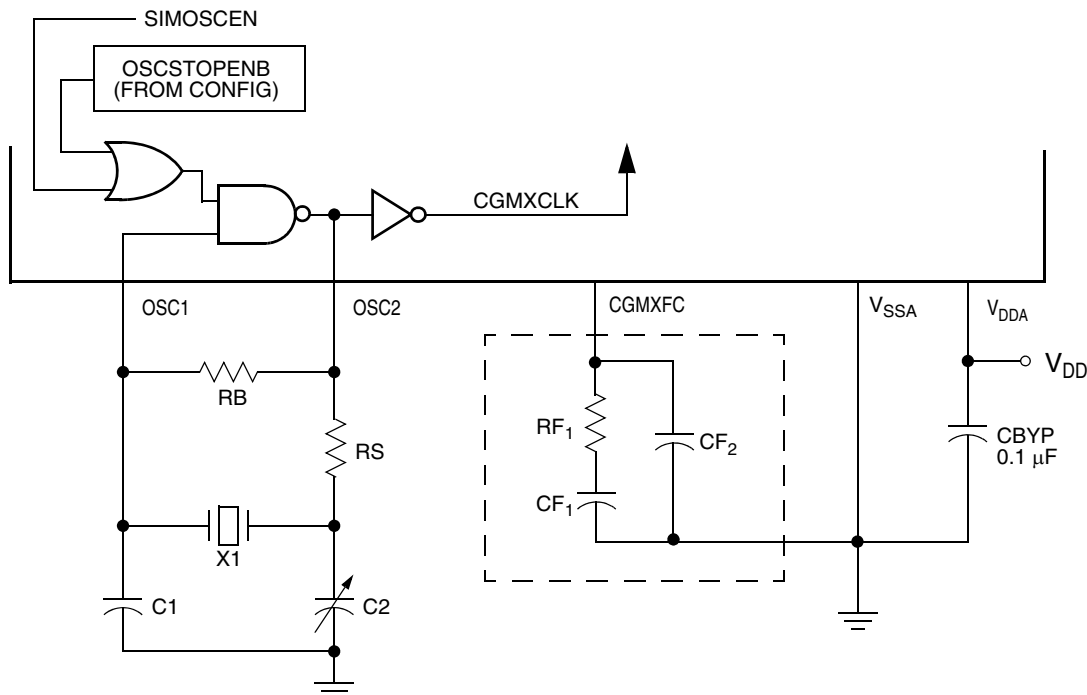
The series resistor ( $R_S$ ) is included in the diagram to follow strict Pierce oscillator guidelines. Refer to the crystal manufacturer's data for more information regarding values for  $C_1$  and  $C_2$ .

[Figure 7-2](#) also shows the external components for the PLL:

- Bypass capacitor,  $C_{BYP}$
- Filter network

Routing should be done with great care to minimize signal cross talk and noise.

See [23.8.1 CGM Component Specifications](#) for capacitor and resistor values.



Note: Filter network in box can be replaced with a 0.47  $\mu\text{F}$  capacitor, but will degrade stability.

**Figure 7-2. CGMC External Connections**

## 7.4 I/O Signals

The following paragraphs describe the CGMC I/O signals.

### 7.4.1 Crystal Amplifier Input Pin (OSC1)

The OSC1 pin is an input to the crystal oscillator amplifier.

### 7.4.2 Crystal Amplifier Output Pin (OSC2)

The OSC2 pin is the output of the crystal oscillator inverting amplifier.

### 7.4.3 External Filter Capacitor Pin (CGMXFC)

The CGMXFC pin is required by the loop filter to filter out phase corrections. An external filter network is connected to this pin. (See [Figure 7-2](#).)

#### **NOTE**

*To prevent noise problems, the filter network should be placed as close to the CGMXFC pin as possible, with minimum routing distances and no routing of other signals across the network.*

#### 7.4.4 PLL Analog Power Pin ( $V_{DDA}$ )

$V_{DDA}$  is a power pin used by the analog portions of the PLL. Connect the  $V_{DDA}$  pin to the same voltage potential as the  $V_{DD}$  pin.

**NOTE**

*Route  $V_{DDA}$  carefully for maximum noise immunity and place bypass capacitors as close as possible to the package.*

#### 7.4.5 PLL Analog Ground Pin ( $V_{SSA}$ )

$V_{SSA}$  is a ground pin used by the analog portions of the PLL. Connect the  $V_{SSA}$  pin to the same voltage potential as the  $V_{SS}$  pin.

**NOTE**

*Route  $V_{SSA}$  carefully for maximum noise immunity and place bypass capacitors as close as possible to the package.*

#### 7.4.6 Oscillator Enable Signal (SIMOSCEN)

The SIMOSCEN signal comes from the system integration module (SIM) and enables the oscillator and PLL.

#### 7.4.7 Oscillator Stop Mode Enable Bit (OSCSTOPENB)

OSCSTOPENB is a bit in the CONFIG register that enables the oscillator to continue operating during stop mode. If this bit is set, the Oscillator continues running during stop mode. If this bit is not set (default), the oscillator is controlled by the SIMOSCEN signal which will disable the oscillator during stop mode.

#### 7.4.8 Crystal Output Frequency Signal (CGMXCLK)

CGMXCLK is the crystal oscillator output signal. It runs at the full speed of the crystal ( $f_{XCLK}$ ) and comes directly from the crystal oscillator circuit. [Figure 7-2](#) shows only the logical relation of CGMXCLK to OSC1 and OSC2 and may not represent the actual circuitry. The duty cycle of CGMXCLK is unknown and may depend on the crystal and other external factors. Also, the frequency and amplitude of CGMXCLK can be unstable at startup.

#### 7.4.9 CGMC Base Clock Output (CGMOUT)

CGMOUT is the clock output of the CGMC. This signal goes to the SIM, which generates the MCU clocks. CGMOUT is a 50 percent duty cycle clock running at twice the bus frequency. CGMOUT is software programmable to be either the oscillator output, CGMXCLK, divided by two or the VCO clock, CGMVCLK, divided by two.

#### 7.4.10 CGMC CPU Interrupt (CGMINT)

CGMINT is the interrupt signal generated by the PLL lock detector.

## 7.5 CGMC Registers

These registers control and monitor operation of the CGMC:

- PLL control register (PCTL)  
(See 7.5.1 PLL Control Register.)
- PLL bandwidth control register (PBWC)  
(See 7.5.2 PLL Bandwidth Control Register.)
- PLL multiplier select register high (PMSH)  
(See 7.5.3 PLL Multiplier Select Register High.)
- PLL multiplier select register low (PMSL)  
(See 7.5.4 PLL Multiplier Select Register Low.)
- PLL VCO range select register (PMRS)  
(See 7.5.5 PLL VCO Range Select Register.)
- PLL reference divider select register (PMDS)  
(See 7.5.6 PLL Reference Divider Select Register.)

Figure 7-3 is a summary of the CGMC registers.

Addr.	Register Name	Bit 7	6	5	4	3	2	1	Bit 0	
\$0036	PLL Control Register (PCTL)	Read:	PLLIE	PLLIF	PLLON	BCS	PRE1	PRE0	VPR1	VPR0
		Write:								
		Reset:	0	0	1	0	0	0	0	0
\$0037	PLL Bandwidth Control Register (PBWC)	Read:	AUTO	LOCK	ACQ	0	0	0	0	R
		Write:								
		Reset:	0	0	0	0	0	0	0	0
\$0038	PLL Multiplier Select High Register (PMSH)	Read:	0	0	0	0	MUL11	MUL10	MUL9	MUL8
		Write:								
		Reset:	0	0	0	0	0	0	0	0
\$0039	PLL Multiplier Select Low Register (PMSL)	Read:	MUL7	MUL6	MUL5	MUL4	MUL3	MUL2	MUL1	MUL0
		Write:								
		Reset:	0	1	0	0	0	0	0	0
\$003A	PLL VCO Select Range Register (PMRS)	Read:	VRS7	VRS6	VRS5	VRS4	VRS3	VRS2	VRS1	VRS0
		Write:								
		Reset:	0	1	0	0	0	0	0	0
\$003B	PLL Reference Divider Select Register (PMDS)	Read:	0	0	0	0	RDS3	RDS2	RDS1	RDS0
		Write:								
		Reset:	0	0	0	0	0	0	0	1

= Unimplemented     
 R = Reserved

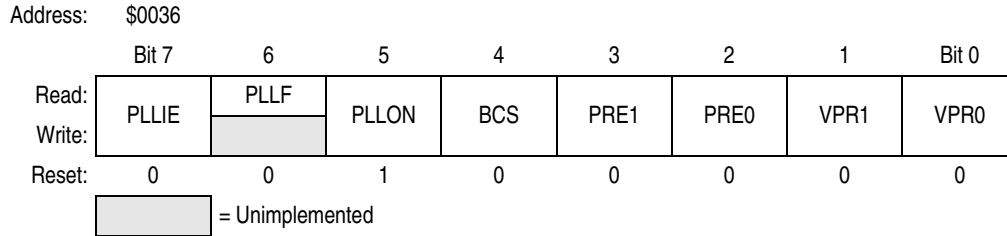
### NOTES:

1. When AUTO = 0, PLLIE is forced clear and is read-only.
2. When AUTO = 0, PLLIF and LOCK read as clear.
3. When AUTO = 1, ACQ is read-only.
4. When PLLON = 0 or VRS7:VRS0 = \$0, BCS is forced clear and is read-only.
5. When PLLON = 1, the PLL programming register is read-only.
6. When BCS = 1, PLLON is forced set and is read-only.

**Figure 7-3. CGMC I/O Register Summary**

### 7.5.1 PLL Control Register

The PLL control register (PCTL) contains the interrupt enable and flag bits, the on/off switch, the base clock selector bit, the prescaler bits, and the VCO power-of-two range selector bits.



**Figure 7-4. PLL Control Register (PCTL)**

#### PLLIE — PLL Interrupt Enable Bit

This read/write bit enables the PLL to generate an interrupt request when the LOCK bit toggles, setting the PLL flag, PLLIF. When the AUTO bit in the PLL bandwidth control register (PBWC) is clear, PLLIE cannot be written and reads as logic 0. Reset clears the PLLIE bit.

- 1 = PLL interrupts enabled
- 0 = PLL interrupts disabled

#### PLLIF — PLL Interrupt Flag Bit

This read-only bit is set whenever the LOCK bit toggles. PLLIF generates an interrupt request if the PLLIE bit also is set. PLLIF always reads as logic 0 when the AUTO bit in the PLL bandwidth control register (PBWC) is clear. Clear the PLLIF bit by reading the PLL control register. Reset clears the PLLIF bit.

- 1 = Change in lock condition
- 0 = No change in lock condition

**NOTE**

*Do not inadvertently clear the PLLIF bit. Any read or read-modify-write operation on the PLL control register clears the PLLIF bit.*

#### PLLON — PLL On Bit

This read/write bit activates the PLL and enables the VCO clock, CGMVCLK. PLLON cannot be cleared if the VCO clock is driving the base clock, CGMOUT (BCS = 1). (See [7.3.8 Base Clock Selector Circuit](#).) Reset sets this bit so that the loop can stabilize as the MCU is powering up.

- 1 = PLL on
- 0 = PLL off

#### BCS — Base Clock Select Bit

This read/write bit selects either the crystal oscillator output, CGMXCLK, or the VCO clock, CGMVCLK, as the source of the CGMC output, CGMOUT. CGMOUT frequency is one-half the frequency of the selected clock. BCS cannot be set while the PLLON bit is clear. After toggling BCS, it may take up to three CGMXCLK and three CGMVCLK cycles to complete the transition from one source clock to the other. During the transition, CGMOUT is held in stasis. (See [7.3.8 Base Clock Selector Circuit](#).) Reset clears the BCS bit.

- 1 = CGMVCLK divided by two drives CGMOUT
- 0 = CGMXCLK divided by two drives CGMOUT

**NOTE**

*PLLON and BCS have built-in protection that prevents the base clock selector circuit from selecting the VCO clock as the source of the base clock*



if the PLL is off. Therefore, PLLON cannot be cleared when BCS is set, and BCS cannot be set when PLLON is clear. If the PLL is off (PLLON = 0), selecting CGMVCLK requires two writes to the PLL control register. (See [7.3.8 Base Clock Selector Circuit](#).)

### PRE1 and PRE0 — Prescaler Program Bits

These read/write bits control a prescaler that selects the prescaler power-of-two multiplier, P. (See [7.3.3 PLL Circuits](#) and [7.3.6 Programming the PLL](#).) PRE1 and PRE0 cannot be written when the PLLON bit is set. Reset clears these bits.

#### NOTE

The value of P is normally 0 when using a 32.768-kHz crystal as the reference.

**Table 7-2. PRE 1 and PRE0 Programming**

PRE1 and PRE0	P	Prescaler Multiplier
00	0	1
01	1	2
10	2	4
11	3	8

### VPR1 and 0 — VCO Power-of-Two Range Select Bits

These read/write bits control the VCO's hardware power-of-two range multiplier E that, in conjunction with L (See [7.3.3 PLL Circuits](#), [7.3.6 Programming the PLL](#), and [7.5.5 PLL VCO Range Select Register](#).) controls the hardware center-of-range frequency,  $f_{VRS}$ . VPR1:VPR0 cannot be written when the PLLON bit is set. Reset clears these bits.

**Table 7-3. VPR1 and VPR0 Programming**

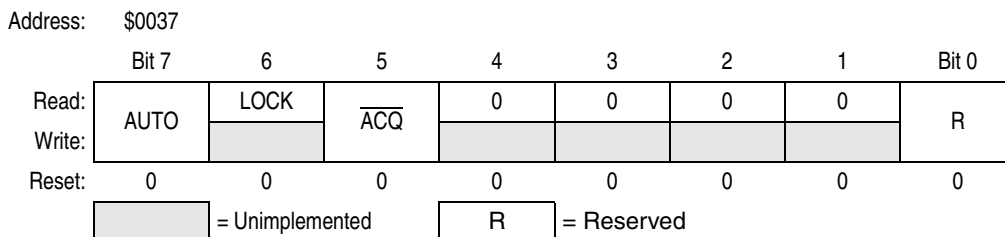
VPR1 and VPR0	E	VCO Power-of-Two Range Multiplier
00	0	1
01	1	2
10	2	4
11	3 <sup>(1)</sup>	8

1. Do not program E to a value of 3.

### 7.5.2 PLL Bandwidth Control Register

The PLL bandwidth control register (PBWC):

- Selects automatic or manual (software-controlled) bandwidth control mode
- Indicates when the PLL is locked
- In automatic bandwidth control mode, indicates when the PLL is in acquisition or tracking mode
- In manual operation, forces the PLL into acquisition or tracking mode



**Figure 7-5. PLL Bandwidth Control Register (PBWC)**

#### AUTO — Automatic Bandwidth Control Bit

This read/write bit selects automatic or manual bandwidth control. When initializing the PLL for manual operation (AUTO = 0), clear the  $\overline{ACQ}$  bit before turning on the PLL. Reset clears the AUTO bit.

- 1 = Automatic bandwidth control
- 0 = Manual bandwidth control

#### LOCK — Lock Indicator Bit

When the AUTO bit is set, LOCK is a read-only bit that becomes set when the VCO clock, CGMVCLK, is locked (running at the programmed frequency). When the AUTO bit is clear, LOCK reads as 0 and has no meaning. The write one function of this bit is reserved for test, so this bit must **always** be written a 0. Reset clears the LOCK bit.

- 1 = VCO frequency correct or locked
- 0 = VCO frequency incorrect or unlocked

#### $\overline{ACQ}$ — Acquisition Mode Bit

When the AUTO bit is set,  $\overline{ACQ}$  is a read-only bit that indicates whether the PLL is in acquisition mode or tracking mode. When the AUTO bit is clear,  $\overline{ACQ}$  is a read/write bit that controls whether the PLL is in acquisition or tracking mode.

In automatic bandwidth control mode (AUTO = 1), the last-written value from manual operation is stored in a temporary location and is recovered when manual operation resumes. Reset clears this bit, enabling acquisition mode.

- 1 = Tracking mode
- 0 = Acquisition mode

### 7.5.3 PLL Multiplier Select Register High

The PLL multiplier select register high (PMSH) contains the programming information for the high byte of the modulo feedback divider.

Address: \$0038

	Bit 7	6	5	4	3	2	1	Bit 0
Read:	0	0	0	0	MUL11	MUL10	MUL9	MUL8
Write:								
Reset:	0	0	0	0	0	0	0	0


 = Unimplemented

Figure 7-6. PLL Multiplier Select Register High (PMSH)

#### MUL11–MUL8 — Multiplier Select Bits

These read/write bits control the high byte of the modulo feedback divider that selects the VCO frequency multiplier N. (See [7.3.3 PLL Circuits](#) and [7.3.6 Programming the PLL](#).) A value of \$0000 in the multiplier select registers configures the modulo feedback divider the same as a value of \$0001. Reset initializes the registers to \$0040 for a default multiply value of 64.

#### NOTE

*The multiplier select bits have built-in protection such that they cannot be written when the PLL is on (PLLON = 1).*

#### PMSH[7:4] — Unimplemented Bits

These bits have no function and always read as logic 0s.

### 7.5.4 PLL Multiplier Select Register Low

The PLL multiplier select register low (PMSL) contains the programming information for the low byte of the modulo feedback divider.

Address: \$0038

	Bit 7	6	5	4	3	2	1	Bit 0
Read:	MUL7	MUL6	MUL5	MUL4	MUL3	MUL2	MUL1	MUL0
Write:								
Reset:	0	1	0	0	0	0	0	0

Figure 7-7. PLL Multiplier Select Register Low (PMSL)

#### MUL7–MUL0 — Multiplier Select Bits

These read/write bits control the low byte of the modulo feedback divider that selects the VCO frequency multiplier, N. (See [7.3.3 PLL Circuits](#) and [7.3.6 Programming the PLL](#).) MUL7–MUL0 cannot be written when the PLLON bit in the PCTL is set. A value of \$0000 in the multiplier select registers configures the modulo feedback divider the same as a value of \$0001. Reset initializes the register to \$40 for a default multiply value of 64.

#### NOTE

*The multiplier select bits have built-in protection such that they cannot be written when the PLL is on (PLLON = 1).*

### 7.5.5 PLL VCO Range Select Register

**NOTE**

*PMRS may be called PVRS on other HC08 derivatives.*

The PLL VCO range select register (PMRS) contains the programming information required for the hardware configuration of the VCO.

Address: \$003A

	Bit 7	6	5	4	3	2	1	Bit 0
Read:	VRS7	VRS6	VRS5	VRS4	VRS3	VRS2	VRS1	VRS0
Write:								
Reset:	0	1	0	0	0	0	0	0

**Figure 7-8. PLL VCO Range Select Register (PMRS)**

#### VRS7–VRS0 — VCO Range Select Bits

These read/write bits control the hardware center-of-range linear multiplier L which, in conjunction with E (see 7.3.3 PLL Circuits, 7.3.6 Programming the PLL, and 7.5.1 PLL Control Register), controls the hardware center-of-range frequency,  $f_{VRS}$ . VRS7–VRS0 cannot be written when the PLLON bit in the PCTL is set. (See 7.3.7 Special Programming Exceptions.) A value of \$00 in the VCO range select register disables the PLL and clears the BCS bit in the PLL control register (PCTL). (See 7.3.8 Base Clock Selector Circuit and 7.3.7 Special Programming Exceptions.). Reset initializes the register to \$40 for a default range multiply value of 64.

**NOTE**

*The VCO range select bits have built-in protection such that they cannot be written when the PLL is on (PLLON = 1) and such that the VCO clock cannot be selected as the source of the base clock (BCS = 1) if the VCO range select bits are all clear.*

*The PLL VCO range select register must be programmed correctly. Incorrect programming can result in failure of the PLL to achieve lock.*

### 7.5.6 PLL Reference Divider Select Register

**NOTE**

*PMDS may be called PRDS on other HC08 derivatives.*

The PLL reference divider select register (PMDS) contains the programming information for the modulo reference divider.

Address: \$003B

	Bit 7	6	5	4	3	2	1	Bit 0
Read:	0	0	0	0	RDS3	RDS2	RDS1	RDS0
Write:								
Reset:	0	0	0	0	0	0	0	1

= Unimplemented

**Figure 7-9. PLL Reference Divider Select Register (PMDS)**

**RDS3–RDS0 — Reference Divider Select Bits**

These read/write bits control the modulo reference divider that selects the reference division factor, R. (See [7.3.3 PLL Circuits](#) and [7.3.6 Programming the PLL](#).) RDS7–RDS0 cannot be written when the PLLON bit in the PCTL is set. A value of \$00 in the reference divider select register configures the reference divider the same as a value of \$01. (See [7.3.7 Special Programming Exceptions](#).) Reset initializes the register to \$01 for a default divide value of 1.

**NOTE**

*The reference divider select bits have built-in protection such that they cannot be written when the PLL is on (PLLON = 1).*

*The default divide value of 1 is recommended for all applications.*

**PMDS7–PMDS4 — Unimplemented Bits**

These bits have no function and always read as logic 0s.

**7.6 Interrupts**

When the AUTO bit is set in the PLL bandwidth control register (PBWC), the PLL can generate a CPU interrupt request every time the LOCK bit changes state. The PLLIE bit in the PLL control register (PCTL) enables CPU interrupts from the PLL. PLLF, the interrupt flag in the PCTL, becomes set whether interrupts are enabled or not. When the AUTO bit is clear, CPU interrupts from the PLL are disabled and PLLF reads as logic 0.

Software should read the LOCK bit after a PLL interrupt request to see if the request was due to an entry into lock or an exit from lock. When the PLL enters lock, the VCO clock, CGMVCLK, divided by two can be selected as the CGMOUT source by setting BCS in the PCTL. When the PLL exits lock, the VCO clock frequency is corrupt, and appropriate precautions should be taken. If the application is not frequency sensitive, interrupts should be disabled to prevent PLL interrupt service routines from impeding software performance or from exceeding stack limitations.

**NOTE**

*Software can select the CGMVCLK divided by two as the CGMOUT source even if the PLL is not locked (LOCK = 0). Therefore, software should make sure the PLL is locked before setting the BCS bit.*

**7.7 Special Modes**

The WAIT instruction puts the MCU in low power-consumption standby modes.

**7.7.1 Wait Mode**

The WAIT instruction does not affect the CGMC. Before entering wait mode, software can disengage and turn off the PLL by clearing the BCS and PLLON bits in the PLL control register (PCTL) to save power. Less power-sensitive applications can disengage the PLL without turning it off, so that the PLL clock is immediately available at WAIT exit. This would be the case also when the PLL is to wake the MCU from wait mode, such as when the PLL is first enabled and waiting for LOCK or LOCK is lost.

## 7.7.2 Stop Mode

If the OSCSTOPENB bit in the CONFIG register is cleared (default), then the STOP instruction disables the CGMC (oscillator and phase locked loop) and holds low all CGMC outputs (CGMXCLK, CGMOUT, and CGMINT).

If the STOP instruction is executed with the VCO clock, CGMVCLK, divided by two driving CGMOUT, the PLL automatically clears the BCS bit in the PLL control register (PCTL), thereby selecting the crystal clock, CGMXCLK, divided by two as the source of CGMOUT. When the MCU recovers from STOP, the crystal clock divided by two drives CGMOUT and BCS remains clear.

If the OSCSTOPENB bit in the CONFIG register is set, then the phase locked loop is shut off but the oscillator will continue to operate in stop mode.

## 7.7.3 CGMC During Break Interrupts

The system integration module (SIM) controls whether status bits in other modules can be cleared during the break state. The BCFE bit in the SIM break flag control register (SBFCR) enables software to clear status bits during the break state. (See [19.7.3 SIM Break Flag Control Register](#).)

To allow software to clear status bits during a break interrupt, write a logic 1 to the BCFE bit. If a status bit is cleared during the break state, it remains cleared when the MCU exits the break state.

To protect the PLLF bit during the break state, write a logic 0 to the BCFE bit. With BCFE at logic 0 (its default state), software can read and write the PLL control register during the break state without affecting the PLLF bit.

## 7.8 Acquisition/Lock Time Specifications

The acquisition and lock times of the PLL are, in many applications, the most critical PLL design parameters. Proper design and use of the PLL ensures the highest stability and lowest acquisition/lock times.

### 7.8.1 Acquisition/Lock Time Definitions

Typical control systems refer to the acquisition time or lock time as the reaction time, within specified tolerances, of the system to a step input. In a PLL, the step input occurs when the PLL is turned on or when it suffers a noise hit. The tolerance is usually specified as a percentage of the step input or when the output settles to the desired value plus or minus a percentage of the frequency change. Therefore, the reaction time is constant in this definition, regardless of the size of the step input. For example, consider a system with a 5 percent acquisition time tolerance. If a command instructs the system to change from 0 Hz to 1 MHz, the acquisition time is the time taken for the frequency to reach  $1\text{ MHz} \pm 50\text{ kHz}$ . Fifty kHz = 5% of the 1-MHz step input. If the system is operating at 1 MHz and suffers a  $-100\text{-kHz}$  noise hit, the acquisition time is the time taken to return from 900 kHz to  $1\text{ MHz} \pm 5\text{ kHz}$ . Five kHz = 5% of the 100-kHz step input.

Other systems refer to acquisition and lock times as the time the system takes to reduce the error between the actual output and the desired output to within specified tolerances. Therefore, the acquisition or lock time varies according to the original error in the output. Minor errors may not even be registered. Typical PLL applications prefer to use this definition because the system requires the output frequency to be within a certain tolerance of the desired frequency regardless of the size of the initial error.

## 7.8.2 Parametric Influences on Reaction Time

Acquisition and lock times are designed to be as short as possible while still providing the highest possible stability. These reaction times are not constant, however. Many factors directly and indirectly affect the acquisition time.

The most critical parameter which affects the reaction times of the PLL is the reference frequency,  $f_{RDV}$ . This frequency is the input to the phase detector and controls how often the PLL makes corrections. For stability, the corrections must be small compared to the desired frequency, so several corrections are required to reduce the frequency error. Therefore, the slower the reference the longer it takes to make these corrections. This parameter is under user control via the choice of crystal frequency  $f_{XCLK}$  and the R value programmed in the reference divider. (See [7.3.3 PLL Circuits](#), [7.3.6 Programming the PLL](#), and [7.5.6 PLL Reference Divider Select Register](#).)

Another critical parameter is the external filter network. The PLL modifies the voltage on the VCO by adding or subtracting charge from capacitors in this network. Therefore, the rate at which the voltage changes for a given frequency error (thus change in charge) is proportional to the capacitance. The size of the capacitor also is related to the stability of the PLL. If the capacitor is too small, the PLL cannot make small enough adjustments to the voltage and the system cannot lock. If the capacitor is too large, the PLL may not be able to adjust the voltage in a reasonable time. (See [7.8.3 Choosing a Filter](#).)

Also important is the operating voltage potential applied to  $V_{DDA}$ . The power supply potential alters the characteristics of the PLL. A fixed value is best. Variable supplies, such as batteries, are acceptable if they vary within a known range at very slow speeds. Noise on the power supply is not acceptable, because it causes small frequency errors which continually change the acquisition time of the PLL.

Temperature and processing also can affect acquisition time because the electrical characteristics of the PLL change. The part operates as specified as long as these influences stay within the specified limits. External factors, however, can cause drastic changes in the operation of the PLL. These factors include noise injected into the PLL through the filter capacitor, filter capacitor leakage, stray impedances on the circuit board, and even humidity or circuit board contamination.

## 7.8.3 Choosing a Filter

As described in [7.8.2 Parametric Influences on Reaction Time](#), the external filter network is critical to the stability and reaction time of the PLL. The PLL is also dependent on reference frequency and supply voltage.

[Figure 7-10](#) shows two types of filter circuits. In low-cost applications, where stability and reaction time of the PLL are not critical, the three component filter network of [Figure 7-10 \(B\)](#) can be replaced by a single capacitor,  $C_F$ , shown in [Figure 7-10 \(A\)](#). Refer to [Table 7-4](#) for recommended filter components at various reference frequencies. For reference frequencies between the values listed in the table, extrapolate to the nearest common capacitor value. In general, a slightly larger capacitor provides more stability at the expense of increased lock time.

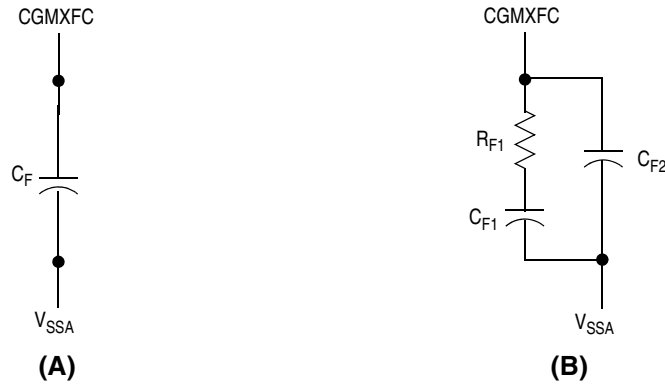


Figure 7-10. PLL Filter

Table 7-4. Example Filter Component Values

$f_{RCLK}$	$C_{F1}$	$C_{F2}$	$R_{F1}$	$C_F$
32 kHz	0.15 $\mu$ F	15 nF	2 K	0.22 $\mu$ F
40 kHz	0.12 $\mu$ F	12 nF	2 K	0.18 $\mu$ F
50 kHz	0.10 $\mu$ F	10 nF	2 K	0.18 $\mu$ F
60 kHz	82 nF	8.2 nF	2 K	0.12 $\mu$ F
70 kHz	68 nF	6.8 nF	2 K	0.12 $\mu$ F
80 kHz	56 nF	5.6 nF	2 K	0.1 $\mu$ F
90 kHz	56 nF	5.6 nF	2 K	0.1 $\mu$ F
100 kHz	47 nF	4.7 nF	2 K	82 nF



# Chapter 8

## Configuration Register (CONFIG)

### 8.1 Introduction

This section describes the configuration registers, CONFIG1 and CONFIG2. The configuration registers enable or disable these options:

- Stop mode recovery time (32 CGMXCLK cycles or 4096 CGMXCLK cycles)
- COP timeout period (262, 128 or 8176 CGMXCLK cycles)
- STOP instruction
- Computer operating properly module (COP)
- Low-voltage inhibit (LVI) module control and voltage trip point selection
- Enable/disable the oscillator (OSC) during stop mode

### 8.2 Functional Description

The configuration registers are used in the initialization of various options. The configuration registers can be written once after each reset. All of the configuration register bits are cleared during reset. Since the various options affect the operation of the MCU, it is recommended that these registers be written immediately after reset. The configuration registers are located at \$001E and \$001F. The configuration register may be read at anytime.

**NOTE**


To ensure correct operation of the MCU under all operating conditions, the user must write data \$1C to address \$0033 immediately after reset. This is to ensure proper termination of an unused module within the MCU.

**NOTE**

*On a FLASH device, the options except LVI5OR3 are one-time writeable by the user after each reset. The LVI5OR3 bit is one-time writeable by the user only after each POR (power-on reset). The CONFIG registers are not in the FLASH memory but are special registers containing one-time writeable latches after each reset. Upon a reset, the CONFIG registers default to predetermined settings as shown in [Figure 8-1](#) and [Figure 8-2](#).*

Address: \$001E

	Bit 7	6	5	4	3	2	1	Bit 0
Read:	0	0	0	0	0	0	OSC-STOPENB	SCIBD-SRC
Write:								
Reset:	0	0	0	0	0	0	0	0

 = Unimplemented

**Figure 8-1. Configuration Register 2 (CONFIG2)**

## Configuration Register (CONFIG)

Address: \$001F

	Bit 7	6	5	4	3	2	1	Bit 0
Read:	COPRS	LVISTOP	LVIRSTD	LVIPWRD	LVI5OR3	SSREC	STOP	COPD
Write:								
Reset:	0	0	0	0	See Note	0	0	0

Note: LVI5OR3 bit is only reset via POR (power-on reset)

**Figure 8-2. Configuration Register 1 (CONFIG1)**

### OSCSTOPENB— Oscillator Stop Mode Enable Bar Bit

OSCSTOPENB enables the oscillator to continue operating during stop mode. Setting the OSCSTOPENB bit allows the oscillator to operate continuously even during stop mode. This is useful for driving the timebase module to allow it to generate periodic wakeup while in stop mode. (See Clock Generator Module (CGM) subsection Stop Mode.)

- 1 = Oscillator enabled to operate during stop mode
- 0 = Oscillator disabled during stop mode (default)

### SCIBDSRC — SCI Baud Rate Clock Source Bit

SCIBDSRC controls the clock source used for the SCI. The setting of this bit affects the frequency at which the SCI operates.

- 1 = Internal data bus clock used as clock source for SCI
- 0 = External oscillator used as clock source for SCI

### COPRS — COP Rate Select Bit

COPRS selects the COP timeout period. Reset clears COPRS. See [Chapter 9 Computer Operating Properly \(COP\)](#).

- 1 = COP timeout period = 8176 CGMXCLK cycles
- 0 = COP timeout period = 262,128 CGMXCLK cycles

### LVISTOP — LVI Enable in Stop Mode Bit

When the LVIPWRD bit is clear, setting the LVISTOP bit enables the LVI to operate during stop mode. Reset clears LVISTOP. See Stop Mode.

- 1 = LVI enabled during stop mode
- 0 = LVI disabled during stop mode

### LVIRSTD — LVI Reset Disable Bit

LVIRSTD disables the reset signal from the LVI module. See [Chapter 14 Low-Voltage Inhibit \(LVI\)](#).

- 1 = LVI module resets disabled
- 0 = LVI module resets enabled

### LVIPWRD — LVI Power Disable Bit

LVIPWRD disables the LVI module. See [Chapter 14 Low-Voltage Inhibit \(LVI\)](#).

- 1 = LVI module power disabled
- 0 = LVI module power enabled

### LVI5OR3 — LVI 5V or 3V Operating Mode Bit

LVI5OR3 selects the voltage operating mode of the LVI module. See [Chapter 14 Low-Voltage Inhibit \(LVI\)](#). The voltage mode selected for the LVI should match the operating  $V_{DD}$ . See [Chapter 23 Electrical Specifications](#) for the LVI's voltage trip points for each of the modes.

- 1 = LVI operates in 5V mode.
- 0 = LVI operates in 3V mode.

### SSREC — Short Stop Recovery Bit

SSREC enables the CPU to exit stop mode with a delay of 32 CGMXCLK cycles instead of a 4096-CGMXCLK cycle delay.

- 1 = Stop mode recovery after 32 CGMXCLK cycles
- 0 = Stop mode recovery after 4096 CGMXCLK cycles

**NOTE**

*Exiting stop mode by pulling reset will result in the long stop recovery. If using an external crystal oscillator, do not set the SSREC bit.*

*When the LVISTOP is enabled, the system stabilization time for power on reset and long stop recovery (both 4096 CGMXCLK cycles) gives a delay longer than the enable time for the LVI. There is no period where the MCU is not protected from a low power condition. However, when using the short stop recovery configuration option, the 32-CGMXCLK delay is less than the LVI's turn-on time and there exists a period in startup where the LVI is not protecting the MCU.*

**STOP — STOP Instruction Enable Bit**

STOP enables the STOP instruction.

- 1 = STOP instruction enabled
- 0 = STOP instruction treated as illegal opcode

**COPD — COP Disable Bit**

COPD disables the COP module. See [Chapter 9 Computer Operating Properly \(COP\)](#)

- 1 = COP module disabled
- 0 = COP module enabled



# Chapter 9

## Computer Operating Properly (COP)

### 9.1 Introduction

The computer operating properly (COP) module contains a free-running counter that generates a reset if allowed to overflow. The COP module helps software recover from runaway code. Prevent a COP reset by clearing the COP counter periodically. The COP module can be disabled through the COPD bit in the CONFIG register.

### 9.2 Functional Description

Figure 9-1 shows the structure of the COP module.

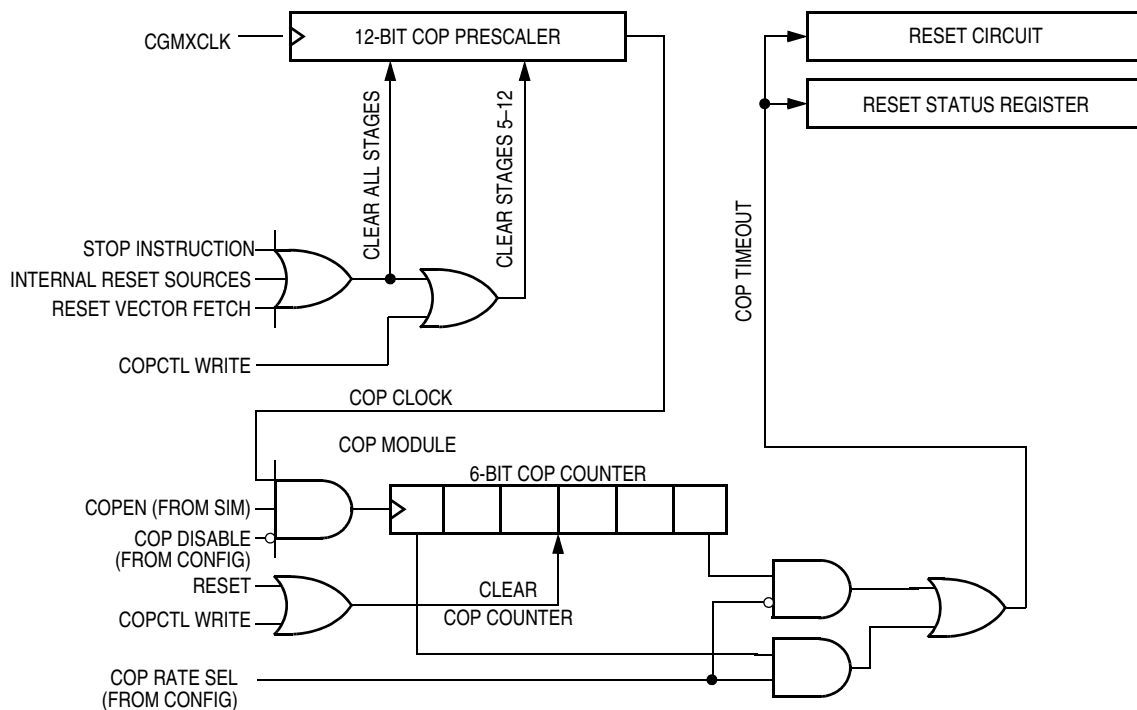


Figure 9-1. COP Block Diagram

## Computer Operating Properly (COP)

The COP counter is a free-running 6-bit counter preceded by a 12-bit prescaler counter. If not cleared by software, the COP counter overflows and generates an asynchronous reset after 262,128 or 8176 CGMXCLK cycles, depending on the state of the COP rate select bit, COPRS, in the configuration register. With a 8176 CGMXCLK cycle overflow option, a 32.768-kHz crystal gives a COP timeout period of 250 ms. Writing any value to location \$FFFF before an overflow occurs prevents a COP reset by clearing the COP counter and stages 12 through 5 of the prescaler.

### NOTE

*Service the COP immediately after reset and before entering or after exiting stop mode to guarantee the maximum time before the first COP counter overflow.*

A COP reset pulls the  $\overline{\text{RST}}$  pin low for 32 CGMXCLK cycles and sets the COP bit in the reset status register (RSR).

In monitor mode, the COP is disabled if the  $\overline{\text{RST}}$  pin or the  $\overline{\text{IRQ}}$  is held at  $V_{\text{TST}}$ . During the break state,  $V_{\text{TST}}$  on the  $\overline{\text{RST}}$  pin disables the COP.

### NOTE

*Place COP clearing instructions in the main program and not in an interrupt subroutine. Such an interrupt subroutine could keep the COP from generating a reset even while the main program is not working properly.*

## 9.3 I/O Signals

The following paragraphs describe the signals shown in [Figure 9-1](#).

### 9.3.1 CGMXCLK

CGMXCLK is the crystal oscillator output signal. CGMXCLK frequency is equal to the crystal frequency.

### 9.3.2 STOP Instruction

The STOP instruction clears the COP prescaler.

### 9.3.3 COPCTL Write

Writing any value to the COP control register (COPCTL) (see COP Control Register) clears the COP counter and clears bits 12 through 5 of the prescaler. Reading the COP control register returns the low byte of the reset vector.

### 9.3.4 Power-On Reset

The power-on reset (POR) circuit clears the COP prescaler 4096 CGMXCLK cycles after power-up.

### 9.3.5 Internal Reset

An internal reset clears the COP prescaler and the COP counter.

### 9.3.6 Reset Vector Fetch

A reset vector fetch occurs when the vector address appears on the data bus. A reset vector fetch clears the COP prescaler.

### 9.3.7 COPD (COP Disable)

The COPD signal reflects the state of the COP disable bit (COPD) in the configuration register. See [Chapter 8 Configuration Register \(CONFIG\)](#).

### 9.3.8 COPRS (COP Rate Select)

The COPRS signal reflects the state of the COP rate select bit (COPRS) in the configuration register. See [Chapter 8 Configuration Register \(CONFIG\)](#).

## 9.4 COP Control Register

The COP control register is located at address \$FFFF and overlaps the reset vector. Writing any value to \$FFFF clears the COP counter and starts a new timeout period. Reading location \$FFFF returns the low byte of the reset vector.

Address: \$FFFF	
	Bit 7      6      5      4      3      2      1      Bit 0
Read:	Low byte of reset vector
Write:	Clear COP counter
Reset:	Unaffected by reset

**Figure 9-2. COP Control Register (COPCTL)**

## 9.5 Interrupts

The COP does not generate CPU interrupt requests.

## 9.6 Monitor Mode

When monitor mode is entered with  $V_{TST}$  on the  $\overline{IRQ}$  pin, the COP is disabled as long as  $V_{TST}$  remains on the  $\overline{IRQ}$  pin or the  $\overline{RST}$  pin. When monitor mode is entered by having blank reset vectors and not having  $V_{TST}$  on the  $\overline{IRQ}$  pin, the COP is automatically disabled until a POR occurs.

## 9.7 Low-Power Modes

The WAIT and STOP instructions put the MCU in low power-consumption standby modes.

### 9.7.1 Wait Mode

The COP remains active during wait mode. If COP is enabled, a reset will occur at COP timeout.

### 9.7.2 Stop Mode

Stop mode turns off the CGMXCLK input to the COP and clears the COP prescaler. Service the COP immediately before entering or after exiting stop mode to ensure a full COP timeout period after entering or exiting stop mode.

## Computer Operating Properly (COP)

To prevent inadvertently turning off the COP with a STOP instruction, a configuration option is available that disables the STOP instruction. When the STOP bit in the configuration register has the STOP instruction disabled, execution of a STOP instruction results in an illegal opcode reset.

### 9.8 COP Module During Break Mode

The COP is disabled during a break interrupt when  $V_{TST}$  is present on the  $\overline{RST}$  pin.



---

# Chapter 10

## Central Processing Unit (CPU)

The M68HC08 CPU (central processor unit) is an enhanced and fully object-code-compatible version of the M68HC05 CPU. The *CPU08 Reference Manual* (document order number CPU08RM/AD) contains a description of the CPU instruction set, addressing modes, and architecture.

### 10.1 Features

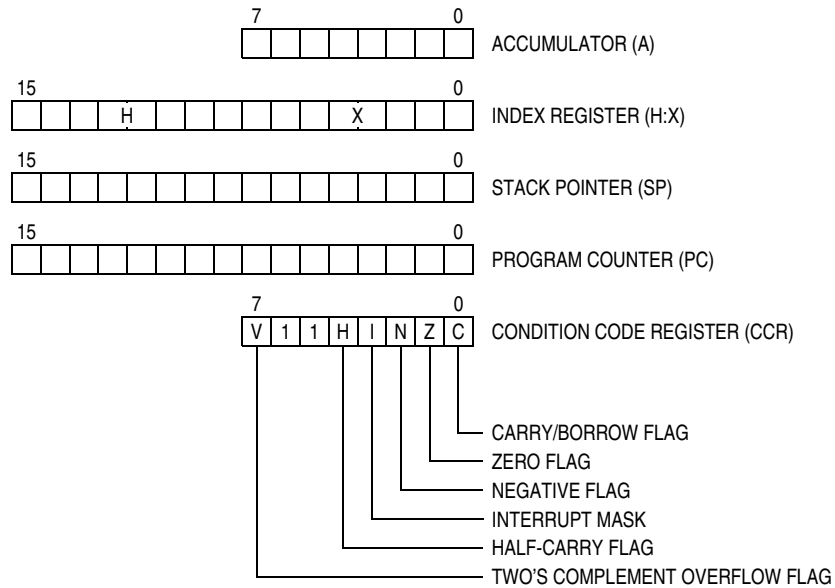
Features of the CPU include:

- Object code fully upward-compatible with M68HC05 Family
- 16-bit stack pointer with stack manipulation instructions
- 16-bit index register with x-register manipulation instructions
- 8-MHz CPU internal bus frequency
- 64-Kbyte program/data memory space
- 16 addressing modes
- Memory-to-memory data moves without using accumulator
- Fast 8-bit by 8-bit multiply and 16-bit by 8-bit divide instructions
- Enhanced binary-coded decimal (BCD) data handling
- Modular architecture with expandable internal bus definition for extension of addressing range beyond 64 Kbytes
- Low-power stop and wait modes

### 10.2 CPU Registers

[Figure 10-1](#) shows the five CPU registers. CPU registers are not part of the memory map.

## Central Processing Unit (CPU)



**Figure 10-1. CPU Registers**

### 10.2.1 Accumulator

The accumulator is a general-purpose 8-bit register. The CPU uses the accumulator to hold operands and the results of arithmetic/logic operations.



**Figure 10-2. Accumulator (A)**

### 10.2.2 Index Register

The 16-bit index register allows indexed addressing of a 64-Kbyte memory space. H is the upper byte of the index register, and X is the lower byte. H:X is the concatenated 16-bit index register.

In the indexed addressing modes, the CPU uses the contents of the index register to determine the conditional address of the operand.

The index register can serve also as a temporary data storage location.



**Figure 10-3. Index Register (H:X)**

### 10.2.3 Stack Pointer

The stack pointer is a 16-bit register that contains the address of the next location on the stack. During a reset, the stack pointer is preset to \$00FF. The reset stack pointer (RSP) instruction sets the least significant byte to \$FF and does not affect the most significant byte. The stack pointer decrements as data is pushed onto the stack and increments as data is pulled from the stack.

In the stack pointer 8-bit offset and 16-bit offset addressing modes, the stack pointer can function as an index register to access data on the stack. The CPU uses the contents of the stack pointer to determine the conditional address of the operand.



**Figure 10-4. Stack Pointer (SP)**

#### NOTE

*The location of the stack is arbitrary and may be relocated anywhere in random-access memory (RAM). Moving the SP out of page 0 (\$0000 to \$00FF) frees direct address (page 0) space. For correct operation, the stack pointer must point only to RAM locations.*

### 10.2.4 Program Counter

The program counter is a 16-bit register that contains the address of the next instruction or operand to be fetched.

Normally, the program counter automatically increments to the next sequential memory location every time an instruction or operand is fetched. Jump, branch, and interrupt operations load the program counter with an address other than that of the next sequential location.

During reset, the program counter is loaded with the reset vector address located at \$FFFE and \$FFFF. The vector address is the address of the first instruction to be executed after exiting the reset state.



**Figure 10-5. Program Counter (PC)**

## 10.2.5 Condition Code Register

The 8-bit condition code register contains the interrupt mask and five flags that indicate the results of the instruction just executed. Bits 6 and 5 are set permanently to 1. The following paragraphs describe the functions of the condition code register.

	Bit 7	6	5	4	3	2	1	Bit 0
Read:	V	1	1	H	I	N	Z	C
Write:								
Reset:	X	1	1	X	1	X	X	X

X = Indeterminate

**Figure 10-6. Condition Code Register (CCR)**

### V — Overflow Flag

The CPU sets the overflow flag when a two's complement overflow occurs. The signed branch instructions BGT, BGE, BLE, and BLT use the overflow flag.

- 1 = Overflow
- 0 = No overflow

### H — Half-Carry Flag

The CPU sets the half-carry flag when a carry occurs between accumulator bits 3 and 4 during an add-without-carry (ADD) or add-with-carry (ADC) operation. The half-carry flag is required for binary-coded decimal (BCD) arithmetic operations. The DAA instruction uses the states of the H and C flags to determine the appropriate correction factor.

- 1 = Carry between bits 3 and 4
- 0 = No carry between bits 3 and 4

### I — Interrupt Mask

When the interrupt mask is set, all maskable CPU interrupts are disabled. CPU interrupts are enabled when the interrupt mask is cleared. When a CPU interrupt occurs, the interrupt mask is set automatically after the CPU registers are saved on the stack, but before the interrupt vector is fetched.

- 1 = Interrupts disabled
- 0 = Interrupts enabled

#### **NOTE**

*To maintain M6805 Family compatibility, the upper byte of the index register (H) is not stacked automatically. If the interrupt service routine modifies H, then the user must stack and unstack H using the PSHH and PULH instructions.*

After the I bit is cleared, the highest-priority interrupt request is serviced first.

A return-from-interrupt (RTI) instruction pulls the CPU registers from the stack and restores the interrupt mask from the stack. After any reset, the interrupt mask is set and can be cleared only by the clear interrupt mask software instruction (CLI).

### N — Negative Flag

The CPU sets the negative flag when an arithmetic operation, logic operation, or data manipulation produces a negative result, setting bit 7 of the result.

- 1 = Negative result
- 0 = Non-negative result

**Z — Zero Flag**

The CPU sets the zero flag when an arithmetic operation, logic operation, or data manipulation produces a result of \$00.

1 = Zero result

0 = Non-zero result

**C — Carry/Borrow Flag**

The CPU sets the carry/borrow flag when an addition operation produces a carry out of bit 7 of the accumulator or when a subtraction operation requires a borrow. Some instructions — such as bit test and branch, shift, and rotate — also clear or set the carry/borrow flag.

1 = Carry out of bit 7

0 = No carry out of bit 7

**10.3 Arithmetic/Logic Unit (ALU)**

The ALU performs the arithmetic and logic operations defined by the instruction set.

Refer to the *CPU08 Reference Manual* (document order number CPU08RM/AD) for a description of the instructions and addressing modes and more detail about the architecture of the CPU.

**10.4 Low-Power Modes**

The WAIT and STOP instructions put the MCU in low power-consumption standby modes.

**10.4.1 Wait Mode**

The WAIT instruction:

- Clears the interrupt mask (I bit) in the condition code register, enabling interrupts. After exit from wait mode by interrupt, the I bit remains clear. After exit by reset, the I bit is set.
- Disables the CPU clock

**10.4.2 Stop Mode**

The STOP instruction:

- Clears the interrupt mask (I bit) in the condition code register, enabling external interrupts. After exit from stop mode by external interrupt, the I bit remains clear. After exit by reset, the I bit is set.
- Disables the CPU clock

After exiting stop mode, the CPU clock begins running after the oscillator stabilization delay.

**10.5 CPU During Break Interrupts**

If a break module is present on the MCU, the CPU starts a break interrupt by:

- Loading the instruction register with the SWI instruction
- Loading the program counter with \$FFFC:\$FFFD or with \$FEFC:\$FEFD in monitor mode

The break interrupt begins after completion of the CPU instruction in progress. If the break address register match occurs on the last cycle of a CPU instruction, the break interrupt begins immediately.

## Central Processing Unit (CPU)

A return-from-interrupt instruction (RTI) in the break routine ends the break interrupt and returns the MCU to normal operation if the break interrupt has been deasserted.

## 10.6 Instruction Set Summary

Table 10-1 provides a summary of the M68HC08 instruction set.

Table 10-1. Instruction Set Summary (Sheet 1 of 6)

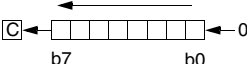
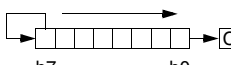
Source Form	Operation	Description	Effect on CCR						Address Mode	Opcode	Operand	Cycles
			V	H	I	N	Z	C				
ADC #opr ADC opr ADC opr ADC opr,X ADC opr,X ADC ,X ADC opr,SP ADC opr,SP	Add with Carry	$A \leftarrow (A) + (M) + (C)$	†	†	-	†	†	†	IMM DIR EXT IX2 IX1 IX SP1 SP2	A9 B9 C9 D9 E9 F9 9EE9 9ED9	ii dd hh ll ee ff ff ff ff ee ff	2 3 4 4 3 2 4 5
ADD #opr ADD opr ADD opr ADD opr,X ADD opr,X ADD ,X ADD opr,SP ADD opr,SP	Add without Carry	$A \leftarrow (A) + (M)$	†	†	-	†	†	†	IMM DIR EXT IX2 IX1 IX SP1 SP2	AB BB CB DB EB FB 9EEB 9EDB	ii dd hh ll ee ff ff ff ff ee ff	2 3 4 4 3 2 4 5
AIS #opr	Add Immediate Value (Signed) to SP	$SP \leftarrow (SP) + (16 \ll M)$	-	-	-	-	-	-	IMM	A7	ii	2
AIX #opr	Add Immediate Value (Signed) to H:X	$H:X \leftarrow (H:X) + (16 \ll M)$	-	-	-	-	-	-	IMM	AF	ii	2
AND #opr AND opr AND opr AND opr,X AND opr,X AND ,X AND opr,SP AND opr,SP	Logical AND	$A \leftarrow (A) \& (M)$	0	-	-	†	†	-	IMM DIR EXT IX2 IX1 IX SP1 SP2	A4 B4 C4 D4 E4 F4 9EE4 9ED4	ii dd hh ll ee ff ff ff ff ee ff	2 3 4 4 3 2 4 5
ASL opr ASLA ASLX ASL opr,X ASL ,X ASL opr,SP	Arithmetic Shift Left (Same as LSL)		†	-	-	†	†	†	DIR INH INH IX1 IX SP1	38 48 58 68 78 9E68	dd ff ff ff	4 1 1 4 3 5
ASR opr ASRA ASRX ASR opr,X ASR opr,X ASR opr,SP	Arithmetic Shift Right		†	-	-	†	†	†	DIR INH INH IX1 IX SP1	37 47 57 67 77 9E67	dd ff ff ff	4 1 1 4 3 5
BCC rel	Branch if Carry Bit Clear	$PC \leftarrow (PC) + 2 + rel ? (C) = 0$	-	-	-	-	-	-	REL	24	rr	3
BCLR n, opr	Clear Bit n in M	$M_n \leftarrow 0$	-	-	-	-	-	-	DIR (b0) DIR (b1) DIR (b2) DIR (b3) DIR (b4) DIR (b5) DIR (b6) DIR (b7)	11 13 15 17 19 1B 1D 1F	dd dd dd dd dd dd dd dd	4 4 4 4 4 4 4 4
BCS rel	Branch if Carry Bit Set (Same as BLO)	$PC \leftarrow (PC) + 2 + rel ? (C) = 1$	-	-	-	-	-	-	REL	25	rr	3
BEQ rel	Branch if Equal	$PC \leftarrow (PC) + 2 + rel ? (Z) = 1$	-	-	-	-	-	-	REL	27	rr	3
BGE opr	Branch if Greater Than or Equal To (Signed Operands)	$PC \leftarrow (PC) + 2 + rel ? (N \oplus V) = 0$	-	-	-	-	-	-	REL	90	rr	3
BGT opr	Branch if Greater Than (Signed Operands)	$PC \leftarrow (PC) + 2 + rel ? (Z) \mid (N \oplus V) = 0$	-	-	-	-	-	-	REL	92	rr	3

Table 10-1. Instruction Set Summary (Sheet 2 of 6)

Source Form	Operation	Description	Effect on CCR					Address Mode	Opcode	Operand	Cycles	
			V	H	I	N	Z					C
BHCC <i>rel</i>	Branch if Half Carry Bit Clear	$PC \leftarrow (PC) + 2 + rel ? (H) = 0$	-	-	-	-	-	REL	28	rr	3	
BHCS <i>rel</i>	Branch if Half Carry Bit Set	$PC \leftarrow (PC) + 2 + rel ? (H) = 1$	-	-	-	-	-	REL	29	rr	3	
BHI <i>rel</i>	Branch if Higher	$PC \leftarrow (PC) + 2 + rel ? (C) \vee (Z) = 0$	-	-	-	-	-	REL	22	rr	3	
BHS <i>rel</i>	Branch if Higher or Same (Same as BCC)	$PC \leftarrow (PC) + 2 + rel ? (C) = 0$	-	-	-	-	-	REL	24	rr	3	
BIH <i>rel</i>	Branch if $\overline{IRQ}$ Pin High	$PC \leftarrow (PC) + 2 + rel ? \overline{IRQ} = 1$	-	-	-	-	-	REL	2F	rr	3	
BIL <i>rel</i>	Branch if $\overline{IRQ}$ Pin Low	$PC \leftarrow (PC) + 2 + rel ? \overline{IRQ} = 0$	-	-	-	-	-	REL	2E	rr	3	
BIT # <i>opr</i> BIT <i>opr</i> BIT <i>opr</i> BIT <i>opr,X</i> BIT <i>opr,X</i> BIT <i>X</i> BIT <i>opr,SP</i> BIT <i>opr,SP</i>	Bit Test	(A) & (M)	0	-	-	†	†	-	IMM DIR EXT IX2 IX1 IX SP1 SP2	A5 B5 C5 D5 E5 F5 9EE5 9ED5	ii dd hh ll ee ff ff ff ff ee ff	2 3 4 4 3 2 4 5
BLE <i>opr</i>	Branch if Less Than or Equal To (Signed Operands)	$PC \leftarrow (PC) + 2 + rel ? (Z) \vee (N \oplus V) = 1$	-	-	-	-	-	REL	93	rr	3	
BLO <i>rel</i>	Branch if Lower (Same as BCS)	$PC \leftarrow (PC) + 2 + rel ? (C) = 1$	-	-	-	-	-	REL	25	rr	3	
BLS <i>rel</i>	Branch if Lower or Same	$PC \leftarrow (PC) + 2 + rel ? (C) \vee (Z) = 1$	-	-	-	-	-	REL	23	rr	3	
BLT <i>opr</i>	Branch if Less Than (Signed Operands)	$PC \leftarrow (PC) + 2 + rel ? (N \oplus V) = 1$	-	-	-	-	-	REL	91	rr	3	
BMC <i>rel</i>	Branch if Interrupt Mask Clear	$PC \leftarrow (PC) + 2 + rel ? (I) = 0$	-	-	-	-	-	REL	2C	rr	3	
BMI <i>rel</i>	Branch if Minus	$PC \leftarrow (PC) + 2 + rel ? (N) = 1$	-	-	-	-	-	REL	2B	rr	3	
BMS <i>rel</i>	Branch if Interrupt Mask Set	$PC \leftarrow (PC) + 2 + rel ? (I) = 1$	-	-	-	-	-	REL	2D	rr	3	
BNE <i>rel</i>	Branch if Not Equal	$PC \leftarrow (PC) + 2 + rel ? (Z) = 0$	-	-	-	-	-	REL	26	rr	3	
BPL <i>rel</i>	Branch if Plus	$PC \leftarrow (PC) + 2 + rel ? (N) = 0$	-	-	-	-	-	REL	2A	rr	3	
BRA <i>rel</i>	Branch Always	$PC \leftarrow (PC) + 2 + rel$	-	-	-	-	-	REL	20	rr	3	
BRCLR <i>n,opr,rel</i>	Branch if Bit <i>n</i> in M Clear	$PC \leftarrow (PC) + 3 + rel ? (Mn) = 0$	-	-	-	-	†	-	DIR (b0) DIR (b1) DIR (b2) DIR (b3) DIR (b4) DIR (b5) DIR (b6) DIR (b7)	01 03 05 07 09 0B 0D 0F	dd rr dd rr dd rr dd rr dd rr dd rr dd rr dd rr	5 5 5 5 5 5 5 5
BRN <i>rel</i>	Branch Never	$PC \leftarrow (PC) + 2$	-	-	-	-	-	REL	21	rr	3	
BRSET <i>n,opr,rel</i>	Branch if Bit <i>n</i> in M Set	$PC \leftarrow (PC) + 3 + rel ? (Mn) = 1$	-	-	-	-	†	-	DIR (b0) DIR (b1) DIR (b2) DIR (b3) DIR (b4) DIR (b5) DIR (b6) DIR (b7)	00 02 04 06 08 0A 0C 0E	dd rr dd rr dd rr dd rr dd rr dd rr dd rr dd rr	5 5 5 5 5 5 5 5
BSET <i>n,opr</i>	Set Bit <i>n</i> in M	$Mn \leftarrow 1$	-	-	-	-	-	-	DIR (b0) DIR (b1) DIR (b2) DIR (b3) DIR (b4) DIR (b5) DIR (b6) DIR (b7)	10 12 14 16 18 1A 1C 1E	dd dd dd dd dd dd dd dd	4 4 4 4 4 4 4 4
BSR <i>rel</i>	Branch to Subroutine	$PC \leftarrow (PC) + 2$ ; push (PCL) $SP \leftarrow (SP) - 1$ ; push (PCH) $SP \leftarrow (SP) - 1$ $PC \leftarrow (PC) + rel$	-	-	-	-	-	REL	AD	rr	4	

Table 10-1. Instruction Set Summary (Sheet 3 of 6)

Source Form	Operation	Description	Effect on CCR					Address Mode	Opcode	Operand	Cycles	
			V	H	I	N	Z					C
CBEQ <i>opr,rel</i> CBEQA # <i>opr,rel</i> CBEQX # <i>opr,rel</i> CBEQ <i>opr,X+,rel</i> CBEQ <i>X+,rel</i> CBEQ <i>opr,SP,rel</i>	Compare and Branch if Equal	PC ← (PC) + 3 + rel ? (A) – (M) = \$00 PC ← (PC) + 3 + rel ? (A) – (M) = \$00 PC ← (PC) + 3 + rel ? (X) – (M) = \$00 PC ← (PC) + 3 + rel ? (A) – (M) = \$00 PC ← (PC) + 2 + rel ? (A) – (M) = \$00 PC ← (PC) + 4 + rel ? (A) – (M) = \$00	–	–	–	–	–	–	DIR IMM IMM IX1+ IX+ SP1	31 41 51 61 71 9E61	dd rr ii rr ii rr ff rr rr ff rr	5 4 4 5 4 6
CLC	Clear Carry Bit	C ← 0	–	–	–	–	0	INH	98		1	
CLI	Clear Interrupt Mask	I ← 0	–	–	0	–	–	INH	9A		2	
CLR <i>opr</i> CLRA CLR X CLR H CLR <i>opr,X</i> CLR ,X CLR <i>opr,SP</i>	Clear	M ← \$00 A ← \$00 X ← \$00 H ← \$00 M ← \$00 M ← \$00 M ← \$00	0	–	–	0	1	–	DIR INH INH INH IX1 IX SP1	3F 4F 5F 8C 6F 7F 9E6F	dd    ff ff	3 1 1 1 3 2 4
CMP # <i>opr</i> CMP <i>opr</i> CMP <i>opr</i> CMP <i>opr,X</i> CMP <i>opr,X</i> CMP ,X CMP <i>opr,SP</i> CMP <i>opr,SP</i>	Compare A with M	(A) – (M)	†	–	–	†	†	†	IMM DIR EXT IX2 IX1 IX SP1 SP2	A1 B1 C1 D1 E1 F1 9EE1 9ED1	ii dd hh ll ee ff ee ff ff ff ee ff	2 3 4 4 3 2 4 5
COM <i>opr</i> COMA COM X COM <i>opr,X</i> COM ,X COM <i>opr,SP</i>	Complement (One's Complement)	M ← (M) = \$FF – (M) A ← (A) = \$FF – (M) X ← (X) = \$FF – (M) M ← (M) = \$FF – (M) M ← (M) = \$FF – (M) M ← (M) = \$FF – (M)	0	–	–	†	†	1	DIR INH INH IX1 IX SP1	33 43 53 63 73 9E63	dd   ff ff	4 1 1 4 3 5
CPHX # <i>opr</i> CPHX <i>opr</i>	Compare H:X with M	(H:X) – (M:M + 1)	†	–	–	†	†	†	IMM DIR	65 75	ii ii+1 dd	3 4
CPX # <i>opr</i> CPX <i>opr</i> CPX <i>opr</i> CPX ,X CPX <i>opr,X</i> CPX <i>opr,X</i> CPX <i>opr,SP</i> CPX <i>opr,SP</i>	Compare X with M	(X) – (M)	†	–	–	†	†	†	IMM DIR EXT IX2 IX1 IX SP1 SP2	A3 B3 C3 D3 E3 F3 9EE3 9ED3	ii dd hh ll ee ff ff ff ff ee ff	2 3 4 4 3 2 4 5
DAA	Decimal Adjust A	(A) <sub>10</sub>	U	–	–	†	†	†	INH	72		2
DBNZ <i>opr,rel</i> DBNZA <i>rel</i> DBNZX <i>rel</i> DBNZ <i>opr,X,rel</i> DBNZ <i>X,rel</i> DBNZ <i>opr,SP,rel</i>	Decrement and Branch if Not Zero	A ← (A) – 1 or M ← (M) – 1 or X ← (X) – 1 PC ← (PC) + 3 + rel ? (result) ≠ 0 PC ← (PC) + 2 + rel ? (result) ≠ 0 PC ← (PC) + 2 + rel ? (result) ≠ 0 PC ← (PC) + 3 + rel ? (result) ≠ 0 PC ← (PC) + 2 + rel ? (result) ≠ 0 PC ← (PC) + 4 + rel ? (result) ≠ 0	–	–	–	–	–	–	DIR INH INH IX1 IX SP1	3B 4B 5B 6B 7B 9E6B	dd rr rr rr ff rr rr ff rr	5 3 3 5 4 6
DEC <i>opr</i> DECA DEC X DEC <i>opr,X</i> DEC ,X DEC <i>opr,SP</i>	Decrement	M ← (M) – 1 A ← (A) – 1 X ← (X) – 1 M ← (M) – 1 M ← (M) – 1 M ← (M) – 1	†	–	–	†	†	–	DIR INH INH IX1 IX SP1	3A 4A 5A 6A 7A 9E6A	dd   ff ff	4 1 1 4 3 5
DIV	Divide	A ← (H:A)/(X) H ← Remainder	–	–	–	–	†	†	INH	52		7
EOR # <i>opr</i> EOR <i>opr</i> EOR <i>opr</i> EOR <i>opr,X</i> EOR <i>opr,X</i> EOR ,X EOR <i>opr,SP</i> EOR <i>opr,SP</i>	Exclusive OR M with A	A ← (A ⊕ M)	0	–	–	†	†	–	IMM DIR EXT IX2 IX1 IX SP1 SP2	A8 B8 C8 D8 E8 F8 9EE8 9ED8	ii dd hh ll ee ff ff ff ff ee ff	2 3 4 4 3 2 4 5



Table 10-1. Instruction Set Summary (Sheet 4 of 6)

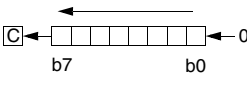
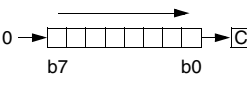
Source Form	Operation	Description	Effect on CCR					Address Mode	Opcode	Operand	Cycles	
			V	H	I	N	Z					C
INC <i>opr</i> INCA INCX INC <i>opr,X</i> INC ,X INC <i>opr,SP</i>	Increment	$M \leftarrow (M) + 1$ $A \leftarrow (A) + 1$ $X \leftarrow (X) + 1$ $M \leftarrow (M) + 1$ $M \leftarrow (M) + 1$ $M \leftarrow (M) + 1$	†	-	-	†	†	-	DIR INH INH IX1 IX SP1	3C 4C 5C 6C 7C 9E6C	dd hh ll ff ff ff	4 1 1 4 3 5
JMP <i>opr</i> JMP <i>opr</i> JMP <i>opr,X</i> JMP <i>opr,X</i> JMP ,X	Jump	PC ← Jump Address	-	-	-	-	-	-	DIR EXT IX2 IX1 IX	BC CC DC EC FC	dd hh ll ee ff ff	2 3 4 3 2
JSR <i>opr</i> JSR <i>opr</i> JSR <i>opr,X</i> JSR <i>opr,X</i> JSR ,X	Jump to Subroutine	PC ← (PC) + <i>n</i> ( <i>n</i> = 1, 2, or 3) Push (PCL); SP ← (SP) - 1 Push (PCH); SP ← (SP) - 1 PC ← Unconditional Address	-	-	-	-	-	-	DIR EXT IX2 IX1 IX	BD CD DD ED FD	dd hh ll ee ff ff	4 5 6 5 4
LDA # <i>opr</i> LDA <i>opr</i> LDA <i>opr</i> LDA <i>opr,X</i> LDA <i>opr,X</i> LDA ,X LDA <i>opr,SP</i> LDA <i>opr,SP</i>	Load A from M	A ← (M)	0	-	-	†	†	-	IMM DIR EXT IX2 IX1 IX SP1 SP2	A6 B6 C6 D6 E6 F6 9EE6 9ED6	ii dd hh ll ee ff ff ff ff ee ff	2 3 4 4 3 2 4 5
LDHX # <i>opr</i> LDHX <i>opr</i>	Load H:X from M	H:X ← (M:M + 1)	0	-	-	†	†	-	IMM DIR	45 55	ii jj dd	3 4
LDX # <i>opr</i> LDX <i>opr</i> LDX <i>opr</i> LDX <i>opr,X</i> LDX <i>opr,X</i> LDX ,X LDX <i>opr,SP</i> LDX <i>opr,SP</i>	Load X from M	X ← (M)	0	-	-	†	†	-	IMM DIR EXT IX2 IX1 IX SP1 SP2	AE BE CE DE EE FE 9EEE 9EDE	ii dd hh ll ee ff ff ff ff ee ff	2 3 4 4 3 2 4 5
LSL <i>opr</i> LSLA LSLX LSL <i>opr,X</i> LSL ,X LSL <i>opr,SP</i>	Logical Shift Left (Same as ASL)		†	-	-	†	†	†	DIR INH INH IX1 IX SP1	38 48 58 68 78 9E68	dd ff ff	4 1 1 4 3 5
LSR <i>opr</i> LSRA LSRX LSR <i>opr,X</i> LSR ,X LSR <i>opr,SP</i>	Logical Shift Right		†	-	-	0	†	†	DIR INH INH IX1 IX SP1	34 44 54 64 74 9E64	dd ff ff	4 1 1 4 3 5
MOV <i>opr,opr</i> MOV <i>opr,X+</i> MOV # <i>opr,opr</i> MOV X+, <i>opr</i>	Move	(M) <sub>Destination</sub> ← (M) <sub>Source</sub> H:X ← (H:X) + 1 (IX+D, DIX+)	0	-	-	†	†	-	DD DIX+ IMD IX+D	4E 5E 6E 7E	dd dd dd ii dd dd	5 4 4 4
MUL	Unsigned multiply	X:A ← (X) × (A)	-	0	-	-	-	0	INH	42		5
NEG <i>opr</i> NEGA NEGX NEG <i>opr,X</i> NEG ,X NEG <i>opr,SP</i>	Negate (Two's Complement)	$M \leftarrow -(M) = \$00 - (M)$ $A \leftarrow -(A) = \$00 - (A)$ $X \leftarrow -(X) = \$00 - (X)$ $M \leftarrow -(M) = \$00 - (M)$ $M \leftarrow -(M) = \$00 - (M)$	†	-	-	†	†	†	DIR INH INH IX1 IX SP1	30 40 50 60 70 9E60	dd ff ff	4 1 1 4 3 5
NOP	No Operation	None	-	-	-	-	-	-	INH	9D		1
NSA	Nibble Swap A	A ← (A[3:0]:A[7:4])	-	-	-	-	-	-	INH	62		3

Table 10-1. Instruction Set Summary (Sheet 5 of 6)

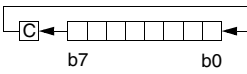
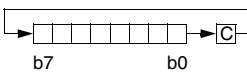
Source Form	Operation	Description	Effect on CCR					Address Mode	Opcode	Operand	Cycles	
			V	H	I	N	Z					C
ORA #opr ORA opr ORA opr ORA opr,X ORA opr,X ORA ,X ORA opr,SP ORA opr,SP	Inclusive OR A and M	$A \leftarrow (A)   (M)$	0	-	-	†	†	-	IMM DIR EXT IX2 IX1 IX SP1 SP2	AA BA CA DA EA FA 9EEA 9EDA	ii dd hh ll ee ff ff ff ee ff	2 3 4 4 3 2 4 5
PSHA	Push A onto Stack	Push (A); $SP \leftarrow (SP) - 1$	-	-	-	-	-	-	INH	87		2
PSHH	Push H onto Stack	Push (H); $SP \leftarrow (SP) - 1$	-	-	-	-	-	-	INH	8B		2
PSHX	Push X onto Stack	Push (X); $SP \leftarrow (SP) - 1$	-	-	-	-	-	-	INH	89		2
PULA	Pull A from Stack	$SP \leftarrow (SP) + 1$ ; Pull (A)	-	-	-	-	-	-	INH	86		2
PULH	Pull H from Stack	$SP \leftarrow (SP) + 1$ ; Pull (H)	-	-	-	-	-	-	INH	8A		2
PULX	Pull X from Stack	$SP \leftarrow (SP) + 1$ ; Pull (X)	-	-	-	-	-	-	INH	88		2
ROL opr ROLA ROLX ROL opr,X ROL ,X ROL opr,SP	Rotate Left through Carry		†	-	-	†	†	†	DIR INH INH IX1 IX SP1	39 49 59 69 79 9E69	dd ff ff	4 1 1 4 3 5
ROR opr RORA RORX ROR opr,X ROR ,X ROR opr,SP	Rotate Right through Carry		†	-	-	†	†	†	DIR INH INH IX1 IX SP1	36 46 56 66 76 9E66	dd ff ff	4 1 1 4 3 5
RSP	Reset Stack Pointer	$SP \leftarrow \$FF$	-	-	-	-	-	-	INH	9C		1
RTI	Return from Interrupt	$SP \leftarrow (SP) + 1$ ; Pull (CCR) $SP \leftarrow (SP) + 1$ ; Pull (A) $SP \leftarrow (SP) + 1$ ; Pull (X) $SP \leftarrow (SP) + 1$ ; Pull (PCH) $SP \leftarrow (SP) + 1$ ; Pull (PCL)	†	†	†	†	†	†	INH	80		7
RTS	Return from Subroutine	$SP \leftarrow SP + 1$ ; Pull (PCH) $SP \leftarrow SP + 1$ ; Pull (PCL)	-	-	-	-	-	-	INH	81		4
SBC #opr SBC opr SBC opr SBC opr,X SBC opr,X SBC ,X SBC opr,SP SBC opr,SP	Subtract with Carry	$A \leftarrow (A) - (M) - (C)$	†	-	-	†	†	†	IMM DIR EXT IX2 IX1 IX SP1 SP2	A2 B2 C2 D2 E2 F2 9EE2 9ED2	ii dd hh ll ee ff ff ff ff ee ff	2 3 4 4 3 2 4 5
SEC	Set Carry Bit	$C \leftarrow 1$	-	-	-	-	-	1	INH	99		1
SEI	Set Interrupt Mask	$I \leftarrow 1$	-	-	1	-	-	-	INH	9B		2
STA opr STA opr STA opr,X STA opr,X STA ,X STA opr,SP STA opr,SP	Store A in M	$M \leftarrow (A)$	0	-	-	†	†	-	DIR EXT IX2 IX1 IX SP1 SP2	B7 C7 D7 E7 F7 9EE7 9ED7	dd hh ll ee ff ff ff ff ee ff	3 4 4 3 2 4 5
STHX opr	Store H:X in M	$(M:M + 1) \leftarrow (H:X)$	0	-	-	†	†	-	DIR	35	dd	4
STOP	Enable Interrupts, Stop Processing, Refer to MCU Documentation	$I \leftarrow 0$ ; Stop Processing	-	-	0	-	-	-	INH	8E		1
STX opr STX opr STX opr,X STX opr,X STX ,X STX opr,SP STX opr,SP	Store X in M	$M \leftarrow (X)$	0	-	-	†	†	-	DIR EXT IX2 IX1 IX SP1 SP2	BF CF DF EF FF 9EEF 9EDF	dd hh ll ee ff ff ff ff ee ff	3 4 4 3 2 4 5

Table 10-1. Instruction Set Summary (Sheet 6 of 6)

Source Form	Operation	Description	Effect on CCR					Address Mode	Opcode	Operand	Cycles	
			V	H	I	N	Z					C
SUB #opr SUB opr SUB opr SUB opr,X SUB opr,X SUB ,X SUB opr,SP SUB opr,SP	Subtract	$A \leftarrow (A) - (M)$	†	-	-	†	†	†	IMM DIR EXT IX2 IX1 IX SP1 SP2	A0 B0 C0 D0 E0 F0 9EE0 9ED0	ii dd hh ll ee ff ff ff ff ff	2 3 4 4 3 2 4 5
SWI	Software Interrupt	PC ← (PC) + 1; Push (PCL) SP ← (SP) - 1; Push (PCH) SP ← (SP) - 1; Push (X) SP ← (SP) - 1; Push (A) SP ← (SP) - 1; Push (CCR) SP ← (SP) - 1; I ← 1 PCH ← Interrupt Vector High Byte PCL ← Interrupt Vector Low Byte	-	-	1	-	-	-	INH	83		9
TAP	Transfer A to CCR	CCR ← (A)	†	†	†	†	†	†	INH	84		2
TAX	Transfer A to X	X ← (A)	-	-	-	-	-	-	INH	97		1
TPA	Transfer CCR to A	A ← (CCR)	-	-	-	-	-	-	INH	85		1
TST opr TSTA TSTX TST opr,X TST ,X TST opr,SP	Test for Negative or Zero	(A) - \$00 or (X) - \$00 or (M) - \$00	0	-	-	†	†	-	DIR INH INH IX1 IX SP1	3D 4D 5D 6D 7D 9E6D	dd ff ff	3 1 1 3 2 4
TSX	Transfer SP to H:X	H:X ← (SP) + 1	-	-	-	-	-	-	INH	95		2
TXA	Transfer X to A	A ← (X)	-	-	-	-	-	-	INH	9F		1
TXS	Transfer H:X to SP	(SP) ← (H:X) - 1	-	-	-	-	-	-	INH	94		2
WAIT	Enable Interrupts; Wait for Interrupt	I bit ← 0; Inhibit CPU clocking until interrupted	-	-	0	-	-	-	INH	8F		1

- |       |   |     |   |
|-------|---|-----|---|
| A     | Accumulator   | n   | Any bit                                     |
| C     | Carry/borrow bit  | opr | Operand (one or two bytes)                  |
| CCR   | Condition code register   | PC  | Program counter                             |
| dd    | Direct address of operand   | PCH | Program counter high byte                   |
| dd rr | Direct address of operand and relative offset of branch instruction | PCL | Program counter low byte                    |
| DD    | Direct to direct addressing mode                                    | REL | Relative addressing mode                    |
| DIR   | Direct addressing mode  | rel | Relative program counter offset byte        |
| DIX+  | Direct to indexed with post increment addressing mode               | rr  | Relative program counter offset byte        |
| ee ff | High and low bytes of offset in indexed, 16-bit offset addressing   | SP1 | Stack pointer, 8-bit offset addressing mode |
| EXT   | Extended addressing mode  | SP2 | Stack pointer 16-bit offset addressing mode |
| ff    | Offset byte in indexed, 8-bit offset addressing                     | SP  | Stack pointer                               |
| H     | Half-carry bit  | U   | Undefined                                   |
| H     | Index register high byte  | V   | Overflow bit                                |
| hh ll | High and low bytes of operand address in extended addressing        | X   | Index register low byte                     |
| I     | Interrupt mask  | Z   | Zero bit                                    |
| ii    | Immediate operand byte  | &   | Logical AND                                 |
| IMD   | Immediate source to direct destination addressing mode              |     | Logical OR                                  |
| IMM   | Immediate addressing mode   | ⊕   | Logical EXCLUSIVE OR                        |
| INH   | Inherent addressing mode  | ()  | Contents of                                 |
| IX    | Indexed, no offset addressing mode                                  | ( ) | Negation (two's complement)                 |
| IX+   | Indexed, no offset, post increment addressing mode                  | #   | Immediate value                             |
| IX+D  | Indexed with post increment to direct addressing mode               | «   | Sign extend                                 |
| IX1   | Indexed, 8-bit offset addressing mode                               | ←   | Loaded with                                 |
| IX1+  | Indexed, 8-bit offset, post increment addressing mode               | ?   | If  |
| IX2   | Indexed, 16-bit offset addressing mode                              | :   | Concatenated with                           |
| M     | Memory location   | †   | Set or cleared                              |
| N     | Negative bit  | —   | Not affected                                |

## 10.7 Opcode Map

See [Table 10-2](#).

Table 10-2. Opcode Map

MSB LSB	Bit Manipulation		Branch	Read-Modify-Write						Control			Register/Memory						
	DIR	DIR	REL	DIR	INH	INH	IX1	SP1	IX	INH	INH	IMM	DIR	EXT	IX2	SP2	IX1	SP1	IX
	0	1	2	3	4	5	6	9E6	7	8	9	A	B	C	D	9ED	E	9EE	F
0	BRSET0 3 DIR	BSET0 2 DIR	BRA 2 REL	NEG 2 DIR	NEGA 1 INH	NEGX 1 INH	NEG 2 IX1	NEG 3 SP1	NEG 1 IX	RTI 1 INH	BGE 2 REL	SUB 2 IMM	SUB 2 DIR	SUB 3 EXT	SUB 3 IX2	SUB 4 SP2	SUB 2 IX1	SUB 3 SP1	SUB 1 IX
1	BRCLR0 3 DIR	BCLR0 2 DIR	BRN 2 REL	CBEQ 3 DIR	CBEQA 3 IMM	CBEQX 3 IMM	CBEQ 3 IX1+	CBEQ 4 SP1	CBEQ 2 IX+	RTS 1 INH	BLT 2 REL	CMP 2 IMM	CMP 2 DIR	CMP 3 EXT	CMP 3 IX2	CMP 4 SP2	CMP 2 IX1	CMP 3 SP1	CMP 1 IX
2	BRSET1 3 DIR	BSET1 2 DIR	BHI 2 REL		MUL 1 INH	DIV 1 INH	NSA 1 INH		DAA 1 INH		BGT 2 REL	SBC 2 IMM	SBC 2 DIR	SBC 3 EXT	SBC 3 IX2	SBC 4 SP2	SBC 2 IX1	SBC 3 SP1	SBC 1 IX
3	BRCLR1 3 DIR	BCLR1 2 DIR	BLS 2 REL	COM 2 DIR	COMA 1 INH	COMX 1 INH	COM 2 IX1	COM 3 SP1	COM 1 IX	SWI 1 INH	BLE 2 REL	CPX 2 IMM	CPX 2 DIR	CPX 3 EXT	CPX 3 IX2	CPX 4 SP2	CPX 2 IX1	CPX 3 SP1	CPX 1 IX
4	BRSET2 3 DIR	BSET2 2 DIR	BCC 2 REL	LSR 2 DIR	LSRA 1 INH	LSRX 1 INH	LSR 2 IX1	LSR 3 SP1	LSR 1 IX	TAP 1 INH	TXS 1 INH	AND 2 IMM	AND 2 DIR	AND 3 EXT	AND 3 IX2	AND 4 SP2	AND 2 IX1	AND 3 SP1	AND 1 IX
5	BRCLR2 3 DIR	BCLR2 2 DIR	BCS 2 REL	STHX 2 DIR	LDHX 3 IMM	LDHX 2 DIR	CPHX 3 IMM		CPHX 2 DIR	TPA 1 INH	TSX 1 INH	BIT 2 IMM	BIT 2 DIR	BIT 3 EXT	BIT 3 IX2	BIT 4 SP2	BIT 2 IX1	BIT 3 SP1	BIT 1 IX
6	BRSET3 3 DIR	BSET3 2 DIR	BNE 2 REL	ROR 2 DIR	RORA 1 INH	RORX 1 INH	ROR 2 IX1	ROR 3 SP1	ROR 1 IX	PULA 1 INH		LDA 2 IMM	LDA 2 DIR	LDA 3 EXT	LDA 3 IX2	LDA 4 SP2	LDA 2 IX1	LDA 3 SP1	LDA 1 IX
7	BRCLR3 3 DIR	BCLR3 2 DIR	BEQ 2 REL	ASR 2 DIR	ASRA 1 INH	ASRX 1 INH	ASR 2 IX1	ASR 3 SP1	ASR 1 IX	PSHA 1 INH	TAX 1 INH	AIS 2 IMM	STA 2 DIR	STA 3 EXT	STA 3 IX2	STA 4 SP2	STA 2 IX1	STA 3 SP1	STA 1 IX
8	BRSET4 3 DIR	BSET4 2 DIR	BHCC 2 REL	LSL 2 DIR	LSLA 1 INH	LSLX 1 INH	LSL 2 IX1	LSL 3 SP1	LSL 1 IX	PULX 1 INH	CLC 1 INH	EOR 2 IMM	EOR 2 DIR	EOR 3 EXT	EOR 3 IX2	EOR 4 SP2	EOR 2 IX1	EOR 3 SP1	EOR 1 IX
9	BRCLR4 3 DIR	BCLR4 2 DIR	BHCS 2 REL	ROL 2 DIR	ROLA 1 INH	ROLX 1 INH	ROL 2 IX1	ROL 3 SP1	ROL 1 IX	PSHX 1 INH	SEC 1 INH	ADC 2 IMM	ADC 2 DIR	ADC 3 EXT	ADC 3 IX2	ADC 4 SP2	ADC 2 IX1	ADC 3 SP1	ADC 1 IX
A	BRSET5 3 DIR	BSET5 2 DIR	BPL 2 REL	DEC 2 DIR	DECA 1 INH	DECX 1 INH	DEC 2 IX1	DEC 3 SP1	DEC 1 IX	PULH 1 INH	CLI 1 INH	ORA 2 IMM	ORA 2 DIR	ORA 3 EXT	ORA 3 IX2	ORA 4 SP2	ORA 2 IX1	ORA 3 SP1	ORA 1 IX
B	BRCLR5 3 DIR	BCLR5 2 DIR	BMI 2 REL	DBNZ 3 DIR	DBNZA 2 INH	DBNZX 2 INH	DBNZ 3 IX1	DBNZ 4 SP1	DBNZ 2 IX	PSHH 1 INH	SEI 1 INH	ADD 2 IMM	ADD 2 DIR	ADD 3 EXT	ADD 3 IX2	ADD 4 SP2	ADD 2 IX1	ADD 3 SP1	ADD 1 IX
C	BRSET6 3 DIR	BSET6 2 DIR	BMC 2 REL	INC 2 DIR	INCA 1 INH	INCX 1 INH	INC 2 IX1	INC 3 SP1	INC 1 IX	CLRH 1 INH	RSP 1 INH		JMP 2 DIR	JMP 3 EXT	JMP 3 IX2		JMP 2 IX1		JMP 1 IX
D	BRCLR6 3 DIR	BCLR6 2 DIR	BMS 2 REL	TST 2 DIR	TSTA 1 INH	TSTX 1 INH	TST 2 IX1	TST 3 SP1	TST 1 IX		NOP 1 INH	BSR 2 REL	JSR 2 DIR	JSR 3 EXT	JSR 3 IX2		JSR 2 IX1		JSR 1 IX
E	BRSET7 3 DIR	BSET7 2 DIR	BIL 2 REL		MOV 3 DD	MOV 2 DIX+	MOV 3 IMD		MOV 2 IX+D	STOP 1 INH	*	LDX 2 IMM	LDX 2 DIR	LDX 3 EXT	LDX 3 IX2	LDX 4 SP2	LDX 2 IX1	LDX 3 SP1	LDX 1 IX
F	BRCLR7 3 DIR	BCLR7 2 DIR	BIH 2 REL	CLR 2 DIR	CLRA 1 INH	CLRFX 1 INH	CLR 2 IX1	CLR 3 SP1	CLR 1 IX	WAIT 1 INH	TXA 1 INH	AIX 2 IMM	STX 2 DIR	STX 3 EXT	STX 3 IX2	STX 4 SP2	STX 2 IX1	STX 3 SP1	STX 1 IX

INH Inherent  
 IMM Immediate  
 DIR Direct  
 EXT Extended  
 DD Direct-Direct  
 IX+D Indexed-Direct  
 REL Relative  
 IX Indexed, No Offset  
 IX1 Indexed, 8-Bit Offset  
 IX2 Indexed, 16-Bit Offset  
 IMM Immediate-Direct  
 DIX+ Direct-Indexed  
 SP1 Stack Pointer, 8-Bit Offset  
 SP2 Stack Pointer, 16-Bit Offset  
 IX+ Indexed, No Offset with Post Increment  
 IX1+ Indexed, 1-Byte Offset with Post Increment

\*Pre-byte for stack pointer indexed instructions

Low Byte of Opcode in Hexadecimal

MSB	0
LSB	5 BRSET0 3 DIR

High Byte of Opcode in Hexadecimal  
 Cycles  
 Opcode Mnemonic  
 Number of Bytes / Addressing Mode

# Chapter 11

## Flash Memory

### 11.1 Introduction

This section describes the operation of the embedded FLASH memory. This memory can be read, programmed, and erased from a single external supply. The program, erase, and read operations are enabled through the use of an internal charge pump.

### 11.2 Functional Description

The FLASH memory is an array of 7,680 bytes for the MC68HC908GR8 or 4,096 bytes for the MC68HC908GR4 with an additional 36 bytes of user vectors and one byte used for block protection. *An erased bit reads as 1 and a programmed bit reads as a 0.* The program and erase operations are facilitated through control bits in the Flash Control Register (FLCR). Details for these operations appear later in this section.

The FLASH is organized internally as a 8192-word by 8-bit CMOS page erase, byte (8-bit) program Embedded Flash Memory. Each page consists of 64 bytes. The page erase operation erases all words within a page. A page is composed of two adjacent rows.

The address ranges for the user memory and vectors are as follows:

- \$E000–\$FDFF; user memory for the MC68HC908GR8  
\$EE00–\$FDFF; user memory for the MC68HC908GR4.
- \$FF7E; FLASH block protect register.
- \$FE08; FLASH control register.
- \$FFDC–\$FFFF; these locations are reserved for user-defined interrupt and reset vectors.

**NOTE**

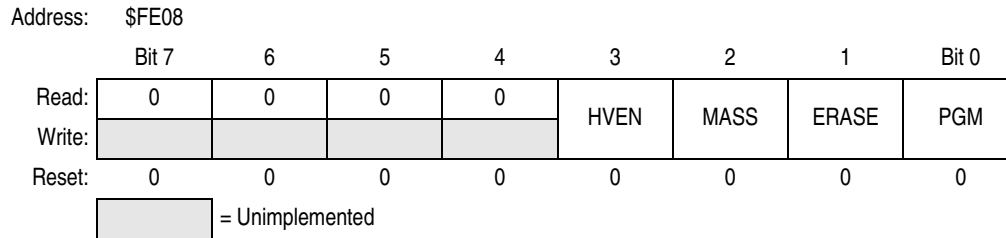
*A security feature prevents viewing of the FLASH contents.<sup>(1)</sup>*

---

1. No security feature is absolutely secure. However, Freescale's strategy is to make reading or copying the FLASH difficult for unauthorized users.

## 11.3 FLASH Control Register

The FLASH control register (FLCR) controls FLASH program and erase operations.



**Figure 11-1. FLASH Control Register (FLCR)**

### HVEN — High-Voltage Enable Bit

This read/write bit enables the charge pump to drive high voltages for program and erase operations in the array. HVEN can only be set if either PGM = 1 or ERASE = 1 and the proper sequence for program or erase is followed.

- 1 = High voltage enabled to array and charge pump on
- 0 = High voltage disabled to array and charge pump off

### MASS — Mass Erase Control Bit

Setting this read/write bit configures the 8K byte FLASH array for mass erase operation.

- 1 = MASS erase operation selected
- 0 = MASS erase operation unselected

### ERASE — Erase Control Bit

This read/write bit configures the memory for erase operation. ERASE is interlocked with the PGM bit such that both bits cannot be equal to 1 or set to 1 at the same time.

- 1 = Erase operation selected
- 0 = Erase operation unselected

### PGM — Program Control Bit

This read/write bit configures the memory for program operation. PGM is interlocked with the ERASE bit such that both bits cannot be equal to 1 or set to 1 at the same time.

- 1 = Program operation selected
- 0 = Program operation unselected

## 11.4 FLASH Page Erase Operation

Use this step-by-step procedure to erase a page (64 bytes) of FLASH memory. A page consists of 64 consecutive bytes starting from addresses \$XX00, \$XX40, \$XX80, or \$XXC0. The user interrupt vector area also forms a page. Any FLASH memory page can be erased alone.

1. Set the ERASE bit, and clear the MASS bit in the FLASH control register.
2. Read the FLASH block protect register.
3. Write any data to any FLASH address within the page address range desired.
4. Wait for a time,  $t_{nvs}$  (min. 10 $\mu$ s)
5. Set the HVEN bit.
6. Wait for a time,  $t_{Erase}$  (min. 1ms)
7. Clear the ERASE bit.

8. Wait for a time,  $t_{nvh}$  (min. 5 $\mu$ s)
9. Clear the HVEN bit.
10. After a time,  $t_{rcv}$  (typ. 1 $\mu$ s), the memory can be accessed again in read mode.

**NOTE**

*While these operations must be performed in the order shown, other unrelated operations may occur between the steps.*

## 11.5 FLASH Mass Erase Operation

Use this step-by-step procedure to erase entire FLASH memory:

1. Set both the ERASE bit, and the MASS bit in the FLASH control register.
2. Read from the FLASH block protect register.
3. Write any data to any FLASH address<sup>(1)</sup> within the FLASH memory address range.
4. Wait for a time,  $t_{nvs}$  (min. 10 $\mu$ s)
5. Set the HVEN bit.
6. Wait for a time,  $t_{MErase}$  (min. 4ms)
7. Clear the ERASE and MASS bits.

**NOTE**

*Mass erase is disabled whenever any block is protected (FLBPR does not equal \$FF).*

8. Wait for a time,  $t_{nvhl}$  (min. 100 $\mu$ s)
9. Clear the HVEN bit.
10. After a time,  $t_{rcv}$  (typical 1 $\mu$ s), the memory can be accessed again in read mode.

**NOTE**

*Programming and erasing of FLASH locations cannot be performed by code being executed from the FLASH memory. While these operations must be performed in the order shown, other unrelated operations may occur between the steps.*

## 11.6 FLASH Program/Read Operation

Programming of the FLASH memory is done on a row basis. A row consists of 32 consecutive bytes starting from addresses \$XX00, \$XX20, \$XX40, \$XX60, \$XX80, \$XXA0, \$XXC0, and \$XXE0. During the programming cycle, make sure that all addresses being written fit within one of the ranges specified above. Attempts to program addresses in different row ranges in one programming cycle will fail. Use this step-by-step procedure to program a row of FLASH memory (Figure 11-2 is a flowchart representation):

**NOTE**

*Only bytes which are currently \$FF may be programmed.*

---

1. When in Monitor mode, with security sequence failed see [Chapter 15 Monitor ROM \(MON\)](#), write to the FLASH block protect register instead of any FLASH address.

## Flash Memory

1. Set the PGM bit. This configures the memory for program operation and enables the latching of address and data for programming.
2. Read from the FLASH block protect register.
3. Write any data to any FLASH address within the row address range desired.
4. Wait for a time,  $t_{NVS}$  (min. 10 $\mu$ s).
5. Set the HVEN bit.
6. Wait for a time,  $t_{PGS}$  (min. 5 $\mu$ s).
7. Write data to the FLASH address to be programmed.
8. Wait for a time,  $t_{PROG}$  (min. 30 $\mu$ s).
9. Repeat step 7 and 8 until all the bytes within the row are programmed.
10. Clear the PGM bit.\*
11. Wait for a time,  $t_{NVH}$  (min. 5 $\mu$ s).
12. Clear the HVEN bit.
13. After time,  $t_{rcv}$  (typical 1 $\mu$ s), the memory can be accessed in read mode again.

This program sequence is repeated throughout the memory until all data is programmed.

### NOTE

*Programming and erasing of FLASH locations cannot be performed by code being executed from the FLASH memory. While these operations must be performed in the order shown, other unrelated operations may occur between the steps. Care must be taken within the FLASH array memory space such as the COP control register (COPCTL) at \$FFFF.*

### NOTE

*It is highly recommended that interrupts be disabled during program/erase operations.*

### NOTE

*Do not exceed  $t_{PROG}$  maximum or  $t_{HV}$  maximum.  $t_{HV}$  is defined as the cumulative high voltage programming time to the same row before next erase.  $t_{HV}$  must satisfy this condition:*

$$t_{NVS} + t_{NVH} + t_{PGS} + (t_{PROG} \times 32) \leq t_{HV} \text{ maximum}$$

*Refer to [23.16 Memory Characteristics](#).*

### NOTE

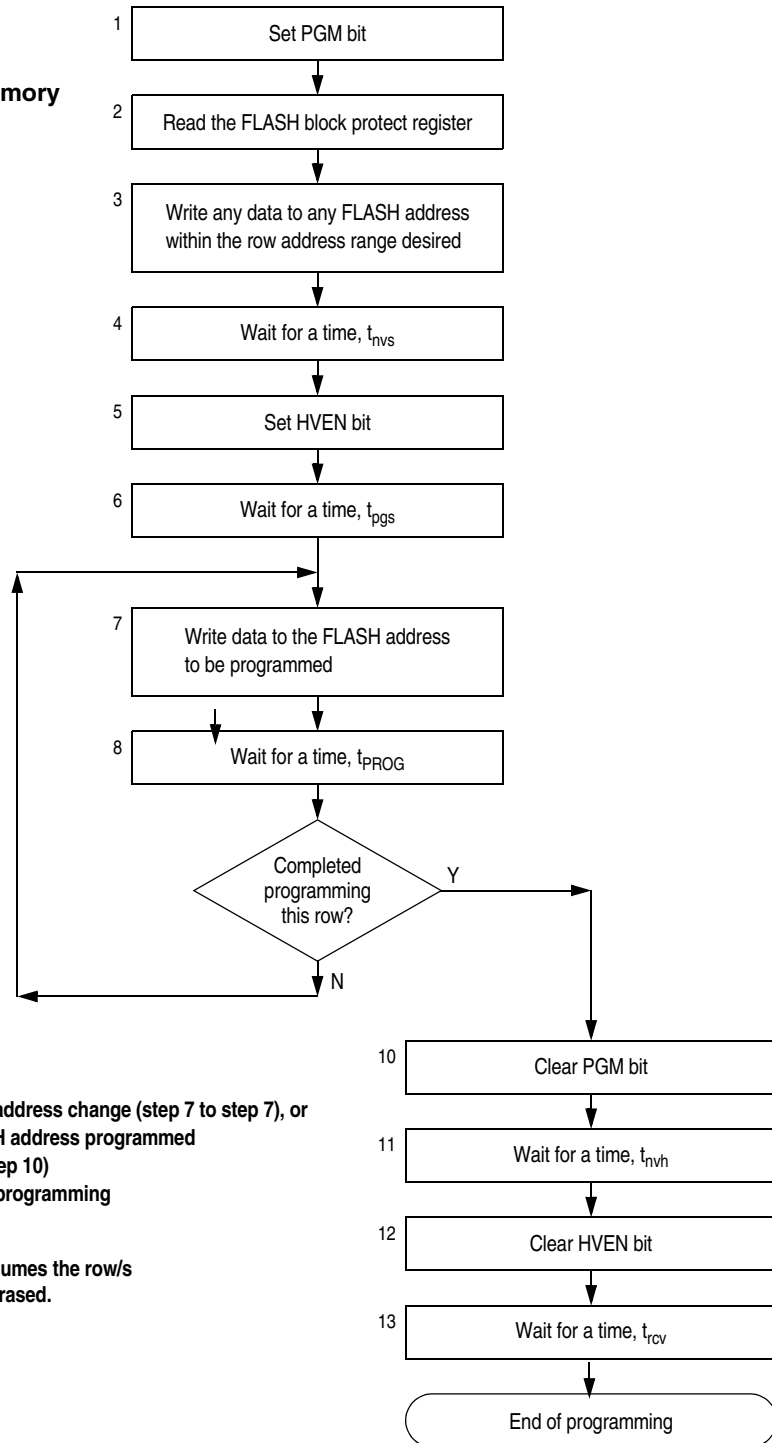
*The time between programming the FLASH address change (step 7 to step 7), or the time between the last FLASH programmed to clearing the PGM bit (step 7 to step 10) must not exceed the maximum programming time,  $t_{PROG}$  maximum.*

### CAUTION

*Be cautious when programming the FLASH array to ensure that non-FLASH locations are not used as the address that is written to when selecting either the desired row address range in step 3 of the algorithm or the byte to be programmed in step 7 of the algorithm. This applies particularly to \$FFD4–\$FFDF.*



**Algorithm for programming  
a row (32 bytes) of FLASH memory**

**NOTE:**

The time between each FLASH address change (step 7 to step 7), or the time between the last FLASH address programmed to clearing PGM bit (step 7 to step 10) must not exceed the maximum programming time,  $t_{\text{PROG max}}$ .

This row program algorithm assumes the row/s to be programmed are initially erased.

**Figure 11-2. FLASH Programming Flowchart**

## 11.7 FLASH Block Protection

Due to the ability of the on-board charge pump to erase and program the FLASH memory in the target application, provision is made for protecting a block of memory from unintentional erase or program operations due to system malfunction. This protection is done by using of a FLASH Block Protect Register (FLBPR). The FLBPR determines the range of the FLASH memory which is to be protected. The range of the protected area starts from a location defined by FLBPR and ends at the bottom of the FLASH memory (\$FFFF). When the memory is protected, the HVEN bit cannot be set in either ERASE or PROGRAM operations.

### NOTE

*In performing a program or erase operation, the FLASH block protect register must be read after setting the PGM or ERASE bit and before asserting the HVEN bit*

When the FLBPR is programmed with all 0s, the entire memory is protected from being programmed and erased. When all the bits are erased (all 1s), the entire memory is accessible for program and erase.

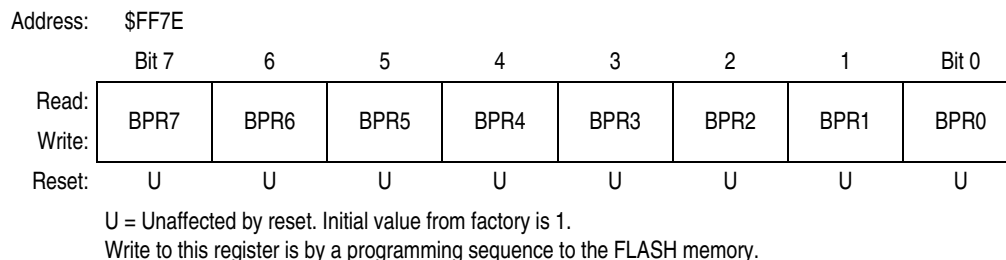
When bits within the FLBPR are programmed, they lock a block of memory with address ranges as shown in [FLASH Block Protect Register](#). Once the FLBPR is programmed with a value other than \$FF, any erase or program of the FLBPR or the protected block of FLASH memory is prohibited. Mass erase is disabled whenever any block is protected (FLBPR does not equal \$FF). The presence of a  $V_{TST}$  on the  $\overline{IRQ}$  pin will bypass the block protection so that all of the memory included in the block protect register is open for program and erase operation.

### NOTE

*The FLASH block protect register is not protected with special hardware or software. Therefore, if this page is not protected by FLBPR, the register is erased by either a page or mass erase operation.*

### 11.7.1 FLASH Block Protect Register

The FLASH block protect register (FLBPR) is implemented as a byte within the FLASH memory, and therefore can only be written during a programming sequence of the FLASH memory. The value in this register determines the starting location of the protected range within the FLASH memory.

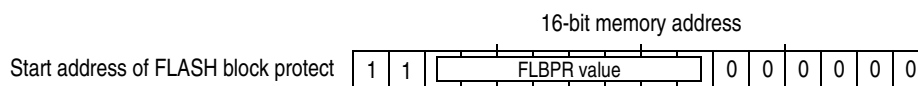


**Figure 11-3. FLASH Block Protect Register (FLBPR)**

#### BPR[7:0] — FLASH Block Protect Bits

These eight bits represent bits [13:6] of a 16-bit memory address. Bits [15:14] are 1s and bits [5:0] are 0s.

The resultant 16-bit address is used for specifying the start address of the FLASH memory for block protection. The FLASH is protected from this start address to the end of FLASH memory, at \$FFFF. With this mechanism, the protect start address can be \$XX00, \$XX40, \$XX80, and \$XXC0 (64 bytes page boundaries) within the FLASH memory.



**Figure 11-4. FLASH Block Protect Start Address**

Examples of protect start address:

**Table 11-1. Examples of Protect Start Address**

BPR[7:0]	Start of Address of Protect Range
\$80	The entire FLASH memory is protected.
\$81 (1000 0001)	\$E040 (1110 0000 0100 0000)
\$82 (1000 0010)	\$E080 (1110 0000 1000 0000)
	and so on...
\$FE (1111 1110)	\$FF80 (1111 1111 1000 0000)
\$FF	The entire FLASH memory is not protected.

Note: The end address of the protected range is always \$FFFF.

## 11.8 Wait Mode

Putting the MCU into wait mode while the FLASH is in read mode does not affect the operation of the FLASH memory directly, but there will not be any memory activity since the CPU is inactive.

The WAIT instruction should not be executed while performing a program or erase operation on the FLASH, otherwise the operation will discontinue, and the FLASH will be on Standby Mode.

## 11.9 STOP Mode

Putting the MCU into stop mode while the FLASH is in read mode does not affect the operation of the FLASH memory directly, but there will not be any memory activity since the CPU is inactive.

The STOP instruction should not be executed while performing a program or erase operation on the FLASH, otherwise the operation will discontinue, and the FLASH will be on Standby Mode

### NOTE

*Standby Mode is the power saving mode of the FLASH module in which all internal control signals to the FLASH are inactive and the current consumption of the FLASH is at a minimum.*



# Chapter 12

## External Interrupt (IRQ)

### 12.1 Introduction

The IRQ (external interrupt) module provides a maskable interrupt input.

### 12.2 Features

Features of the IRQ module include:

- A dedicated external interrupt pin ( $\overline{\text{IRQ}}$ )
- IRQ interrupt control bits
- Hysteresis buffer
- Programmable edge-only or edge and level interrupt sensitivity
- Automatic interrupt acknowledge
- Internal pullup resistor

### 12.3 Functional Description

A logic 0 applied to the external interrupt pin can latch a CPU interrupt request. [Figure 12-1](#) shows the structure of the IRQ module.

Interrupt signals on the  $\overline{\text{IRQ}}$  pin are latched into the IRQ latch. An interrupt latch remains set until one of the following actions occurs:

- Vector fetch — A vector fetch automatically generates an interrupt acknowledge signal that clears the latch that caused the vector fetch.
- Software clear — Software can clear an interrupt latch by writing to the appropriate acknowledge bit in the interrupt status and control register (INTSCR). Writing a logic 1 to the ACK bit clears the IRQ latch.
- Reset — A reset automatically clears the interrupt latch.

The external interrupt pin is falling-edge-triggered out of reset and is software-configurable to be either falling-edge or falling-edge and low-level-triggered. The MODE bit in the INTSCR controls the triggering sensitivity of the  $\overline{\text{IRQ}}$  pin.

When an interrupt pin is edge-triggered only (MODE = 0), the interrupt remains set until a vector fetch, software clear, or reset occurs.

## External Interrupt (IRQ)

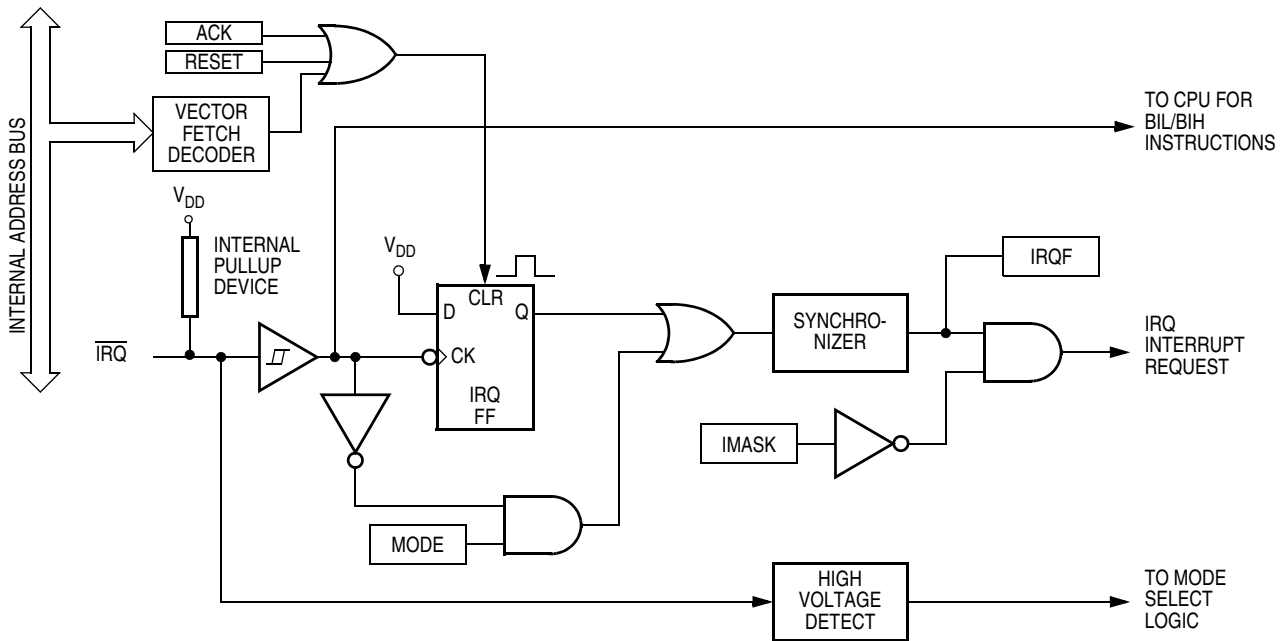


Figure 12-1. IRQ Module Block Diagram

Addr.	Register Name	Bit 7	6	5	4	3	2	1	Bit 0	
\$001D	IRQ Status and Control Register (INTSCR)	Read:	0	0	0	0	IRQF	0	IMASK	MODE
		Write:						ACK		
		Reset:	0	0	0	0	0	0	0	0

□ = Unimplemented

Figure 12-2. IRQ I/O Register Summary

When an interrupt pin is both falling-edge and low-level-triggered, the interrupt remains set until both of the following occur:

- Vector fetch or software clear
- Return of the interrupt pin to high level

The vector fetch or software clear may occur before or after the interrupt pin returns to high level. As long as the pin is low, the interrupt request remains pending. A reset will clear the latch and the MODE control bit, thereby clearing the interrupt even if the pin stays low.

When set, the IMASK bit in the INTSCR mask all external interrupt requests. A latched interrupt request is not presented to the interrupt priority logic unless the IMASK bit is clear.

### NOTE

*The interrupt mask (I) in the condition code register (CCR) masks all interrupt requests, including external interrupt requests.*

## 12.4 $\overline{\text{IRQ}}$ Pin

A falling edge on the  $\overline{\text{IRQ}}$  pin can latch an interrupt request into the IRQ latch. A vector fetch, software clear, or reset clears the IRQ latch.

If the MODE bit is set, the  $\overline{\text{IRQ}}$  pin is both falling-edge-sensitive and low-level-sensitive. With MODE set, both of the following actions must occur to clear IRQ:

- Vector fetch or software clear — A vector fetch generates an interrupt acknowledge signal to clear the latch. Software may generate the interrupt acknowledge signal by writing a 1 to the ACK bit in the interrupt status and control register (INTSCR). The ACK bit is useful in applications that poll the  $\overline{\text{IRQ}}$  pin and require software to clear the IRQ latch. Writing to the ACK bit prior to leaving an interrupt service routine can also prevent spurious interrupts due to noise. Setting ACK does not affect subsequent transitions on the  $\overline{\text{IRQ}}$  pin. A falling edge that occurs after writing to the ACK bit another interrupt request. If the IRQ mask bit, IMASK, is clear, the CPU loads the program counter with the vector address at locations \$FFFA and \$FFFB.
- Return of the  $\overline{\text{IRQ}}$  pin to a high level — As long as the  $\overline{\text{IRQ}}$  pin is at a low level, IRQ remains active.

The vector fetch or software clear and the return of the  $\overline{\text{IRQ}}$  pin to a high level may occur in any order. The interrupt request remains pending as long as the  $\overline{\text{IRQ}}$  pin is low. A reset will clear the latch and the MODE control bit, thereby clearing the interrupt even if the pin stays low.

If the MODE bit is clear, the  $\overline{\text{IRQ}}$  pin is falling-edge-sensitive only. With MODE clear, a vector fetch or software clear immediately clears the IRQ latch.

The IRQF bit in the INTSCR register can be used to check for pending interrupts. The IRQF bit is not affected by the IMASK bit, which makes it useful in applications where polling is preferred.

Use the BIH or BIL instruction to read the logic level on the  $\overline{\text{IRQ}}$  pin.

### **NOTE**

*When using the level-sensitive interrupt trigger, avoid false interrupts by masking interrupt requests in the interrupt routine.*

## 12.5 IRQ Module During Break Interrupts

The BCFE bit in the SIM break flag control register (SBFCR) enables software to clear the latch during the break state. See [Chapter 6 Break Module \(BRK\)](#).

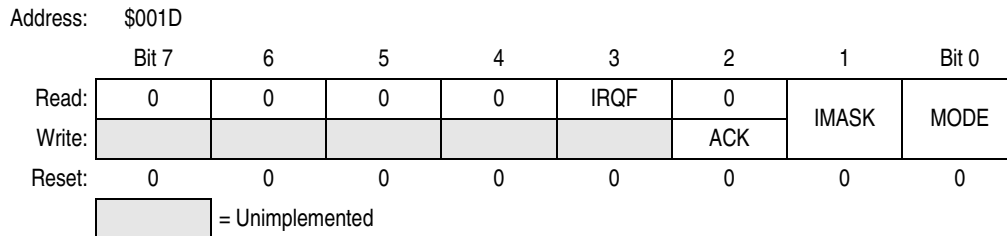
To allow software to clear the IRQ latch during a break interrupt, write a 1 to the BCFE bit. If a latch is cleared during the break state, it remains cleared when the MCU exits the break state.

To protect CPU interrupt flags during the break state, write a 0 to the BCFE bit. With BCFE at 0 (its default state), writing to the ACK bit in the IRQ status and control register during the break state has no effect on the IRQ interrupt flags.

## 12.6 IRQ Status and Control Register

The IRQ status and control register (INTSCR) controls and monitors operation of the IRQ module. The INTSCR:

- Shows the state of the IRQ flag
- Clears the IRQ latch
- Masks IRQ interrupt request
- Controls triggering sensitivity of the  $\overline{\text{IRQ}}$  interrupt pin



**Figure 12-3. IRQ Status and Control Register (INTSCR)**

### IRQF — IRQ Flag Bit

This read-only status bit is high when the IRQ interrupt is pending.

1 =  $\overline{\text{IRQ}}$  interrupt pending

0 =  $\overline{\text{IRQ}}$  interrupt not pending

### ACK — IRQ Interrupt Request Acknowledge Bit

Writing a 1 to this write-only bit clears the IRQ latch. ACK always reads as logic 0. Reset clears ACK.

### IMASK — IRQ Interrupt Mask Bit

Writing a 1 to this read/write bit disables IRQ interrupt requests. Reset clears IMASK.

1 = IRQ interrupt requests disabled

0 = IRQ interrupt requests enabled

### MODE — IRQ Edge/Level Select Bit

This read/write bit controls the triggering sensitivity of the  $\overline{\text{IRQ}}$  pin. Reset clears MODE.

1 =  $\overline{\text{IRQ}}$  interrupt requests on falling edges and low levels

0 =  $\overline{\text{IRQ}}$  interrupt requests on falling edges only



# Chapter 13

## Keyboard Interrupt (KBI)

### 13.1 Introduction

The keyboard interrupt module (KBI) provides four independently maskable external interrupts which are accessible via PTA0–PTA3. When a port pin is enabled for keyboard interrupt function, an internal pullup device is also enabled on the pin.

### 13.2 Features

- Four keyboard interrupt pins with separate keyboard interrupt enable bits and one keyboard interrupt mask
- Hysteresis buffers
- Programmable edge-only or edge- and level- interrupt sensitivity
- Exit from low-power modes
- I/O (input/output) port bit(s) software configurable with pullup device(s) if configured as input port bit(s)

### 13.3 Functional Description

Writing to the KBIE3–KBIE0 bits in the keyboard interrupt enable register independently enables or disables each port A pin as a keyboard interrupt pin. Enabling a keyboard interrupt pin also enables its internal pullup device. A low level applied to an enabled keyboard interrupt pin latches a keyboard interrupt request.

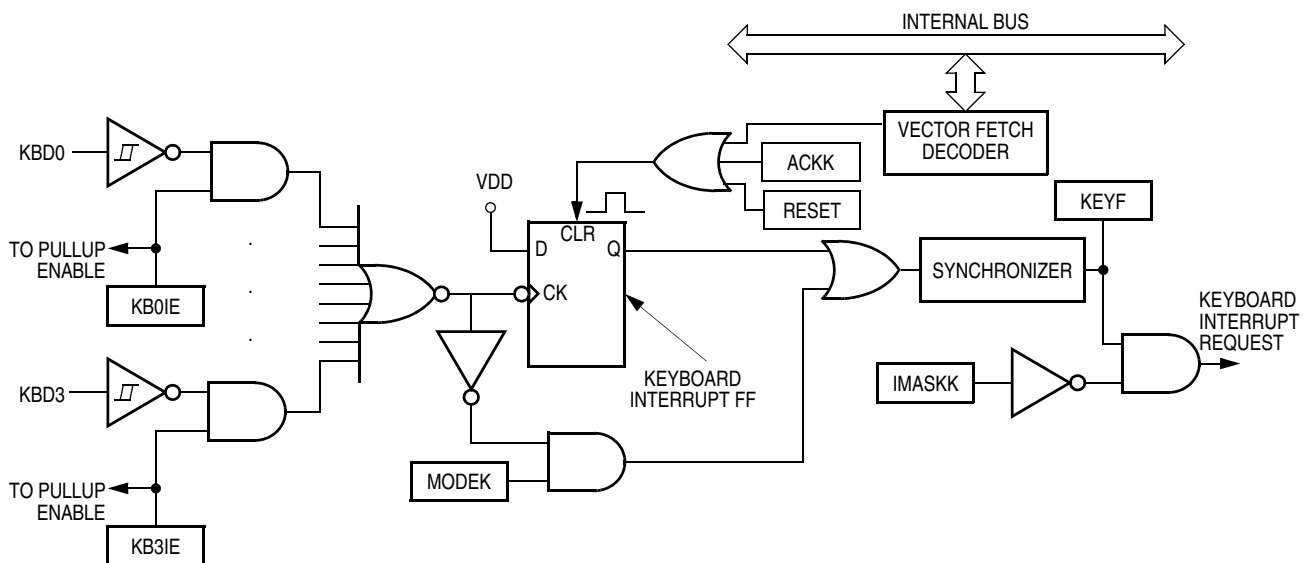


Figure 13-1. Keyboard Module Block Diagram

## Keyboard Interrupt (KBI)

Addr.	Register Name	Bit 7	6	5	4	3	2	1	Bit 0	
\$001A	Keyboard Status and Control Register (INTKBSCR)	Read:	0	0	0	0	KEYF	0	IMASKK	MODEK
		Write:						ACKK		
		Reset:	0	0	0	0	0	0	0	0
\$001B	Keyboard Interrupt Enable Register (INTKBIER)	Read:	0	0	0	0	KBIE3	KBIE2	KBIE1	KBIE0
		Write:								
		Reset:					0	0	0	0

= Unimplemented

**Figure 13-2. I/O Register Summary**

A keyboard interrupt is latched when one or more keyboard pins goes low after all were high. The MODEK bit in the keyboard status and control register controls the triggering mode of the keyboard interrupt.

- If the keyboard interrupt is edge-sensitive only, a falling edge on a keyboard pin does not latch an interrupt request if another keyboard pin is already low. To prevent losing an interrupt request on one pin because another pin is still low, software can disable the latter pin while it is low.
- If the keyboard interrupt is falling-edge and low-level sensitive, an interrupt request is present as long as any keyboard interrupt pin is low and the pin is keyboard interrupt enabled.

If the MODEK bit is set, the keyboard interrupt pins are both falling edge- and low-level sensitive, and both of the following actions must occur to clear a keyboard interrupt request:

- Vector fetch or software clear — A vector fetch generates an interrupt acknowledge signal to clear the interrupt request. Software may generate the interrupt acknowledge signal by writing a 1 to the ACKK bit in the keyboard status and control register (INTKBSCR). The ACKK bit is useful in applications that poll the keyboard interrupt pins and require software to clear the keyboard interrupt request. Writing to the ACKK bit prior to leaving an interrupt service routine can also prevent spurious interrupts due to noise. Setting ACKK does not affect subsequent transitions on the keyboard interrupt pins. A falling edge that occurs after writing to the ACKK bit latches another interrupt request. If the keyboard interrupt mask bit, IMASKK, is clear, the CPU loads the program counter with the vector address at locations \$FFE0 and \$FFE1.
- Return of all enabled keyboard interrupt pins to a high level — As long as any enabled keyboard interrupt pin is low, the keyboard interrupt remains set.

The vector fetch or software clear and the return of all enabled keyboard interrupt pins to a high level may occur in any order.

If the MODEK bit is clear, the keyboard interrupt pin is falling-edge-sensitive only. With MODEK clear, a vector fetch or software clear immediately clears the keyboard interrupt request.

Reset clears the keyboard interrupt request and the MODEK bit, clearing the interrupt request even if a keyboard interrupt pin stays low.

The keyboard flag bit (KEYF) in the keyboard status and control register can be used to see if a pending interrupt exists. The KEYF bit is not affected by the keyboard interrupt mask bit (IMASKK) which makes it useful in applications where polling is preferred.

To determine the logic level on a keyboard interrupt pin, use the data direction register to configure the pin as an input and read the data register.

**NOTE**

*Setting a keyboard interrupt enable bit (KBIE<sub>x</sub>) forces the corresponding keyboard interrupt pin to be an input, overriding the data direction register. However, the data direction register bit must be a 0 for software to read the pin.*

## 13.4 Keyboard Initialization

When a keyboard interrupt pin is enabled, it takes time for the internal pullup to reach a 1. Therefore, a false interrupt can occur as soon as the pin is enabled.

To prevent a false interrupt on keyboard initialization:

1. Mask keyboard interrupts by setting the IMASKK bit in the keyboard status and control register.
2. Enable the KBI pins by setting the appropriate KBIE<sub>x</sub> bits in the keyboard interrupt enable register.
3. Write to the ACKK bit in the keyboard status and control register to clear any false interrupts.
4. Clear the IMASKK bit.

An interrupt signal on an edge-triggered pin can be acknowledged immediately after enabling the pin. An interrupt signal on an edge- and level-triggered interrupt pin must be acknowledged after a delay that depends on the external load.

Another way to avoid a false interrupt is:

1. Configure the keyboard pins as outputs by setting the appropriate DDRA bits in data direction register A.
2. Write 1s to the appropriate port A data register bits.
3. Enable the KBI pins by setting the appropriate KBIE<sub>x</sub> bits in the keyboard interrupt enable register.

## 13.5 Low-Power Modes

The WAIT and STOP instructions put the MCU in low power-consumption standby modes.

### 13.5.1 Wait Mode

The keyboard module remains active in wait mode. Clearing the IMASKK bit in the keyboard status and control register enables keyboard interrupt requests to bring the MCU out of wait mode.

### 13.5.2 Stop Mode

The keyboard module remains active in stop mode. Clearing the IMASKK bit in the keyboard status and control register enables keyboard interrupt requests to bring the MCU out of stop mode.

## 13.6 Keyboard Module During Break Interrupts

The system integration module (SIM) controls whether the keyboard interrupt latch can be cleared during the break state. The BCFE bit in the SIM break flag control register (SBFCR) enables software to clear status bits during the break state.

## Keyboard Interrupt (KBI)

To allow software to clear the keyboard interrupt latch during a break interrupt, write a 1 to the BCFE bit. If a latch is cleared during the break state, it remains cleared when the MCU exits the break state.

To protect the latch during the break state, write a logic 0 to the BCFE bit. With BCFE at logic 0 (its default state), writing to the keyboard acknowledge bit (ACKK) in the keyboard status and control register during the break state has no effect. See [13.7.1 Keyboard Status and Control Register](#).

## 13.7 I/O Registers

These registers control and monitor operation of the keyboard module:

- Keyboard status and control register (INTKBSCR)
- Keyboard interrupt enable register (INTKBIER)


### 13.7.1 Keyboard Status and Control Register

The keyboard status and control register:

- Flags keyboard interrupt requests
- Acknowledges keyboard interrupt requests
- Masks keyboard interrupt requests
- Controls keyboard interrupt triggering sensitivity

Address: \$001A

	Bit 7	6	5	4	3	2	1	Bit 0
Read:	0	0	0	0	KEYF	0	IMASKK	MODEK
Write:						ACKK		
Reset:	0	0	0	0	0	0	0	0

 = Unimplemented

**Figure 13-3. Keyboard Status and Control Register (INTKBSCR)**

#### Bits 7–4 — Not used

These read-only bits always read as logic 0s.

#### KEYF — Keyboard Flag Bit

This read-only bit is set when a keyboard interrupt is pending. Reset clears the KEYF bit.

- 1 = Keyboard interrupt pending
- 0 = No keyboard interrupt pending

#### ACKK — Keyboard Acknowledge Bit

Writing a 1 to this write-only bit clears the keyboard interrupt request. ACKK always reads as logic 0. Reset clears ACKK.

#### IMASKK — Keyboard Interrupt Mask Bit

Writing a 1 to this read/write bit prevents the output of the keyboard interrupt mask from generating interrupt requests. Reset clears the IMASKK bit.

- 1 = Keyboard interrupt requests masked
- 0 = Keyboard interrupt requests not masked

**MODEK — Keyboard Triggering Sensitivity Bit**

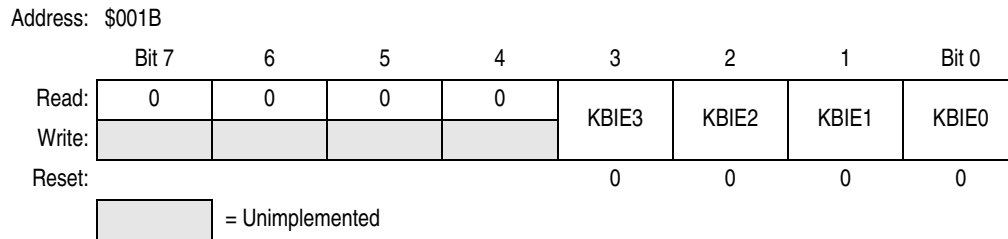
This read/write bit controls the triggering sensitivity of the keyboard interrupt pins. Reset clears MODEK.

1 = Keyboard interrupt requests on falling edges and low levels

0 = Keyboard interrupt requests on falling edges only

**13.7.2 Keyboard Interrupt Enable Register**

The keyboard interrupt enable register enables or disables each port A pin to operate as a keyboard interrupt pin.



**Figure 13-4. Keyboard Interrupt Enable Register (INTKBIER)**

**KBIE3–KBIE0 — Keyboard Interrupt Enable Bits**

Each of these read/write bits enables the corresponding keyboard interrupt pin to latch interrupt requests. Reset clears the keyboard interrupt enable register.

1 = PTAx pin enabled as keyboard interrupt pin

0 = PTAx pin not enabled as keyboard interrupt pin



# Chapter 14

## Low-Voltage Inhibit (LVI)

### 14.1 Introduction

This section describes the low-voltage inhibit (LVI) module, which monitors the voltage on the  $V_{DD}$  pin and can force a reset when the  $V_{DD}$  voltage falls below the LVI trip falling voltage,  $V_{TRIPF}$ .

### 14.2 Features

Features of the LVI module include:

- Programmable LVI reset
- Selectable LVI trip voltage
- Programmable stop mode operation

### 14.3 Functional Description

Figure 14-1 shows the structure of the LVI module. The LVI is enabled out of reset. The LVI module contains a bandgap reference circuit and comparator. Clearing the LVI power disable bit, LVIPWRD, enables the LVI to monitor  $V_{DD}$  voltage. Clearing the LVI reset disable bit, LVIRSTD, enables the LVI module to generate a reset when  $V_{DD}$  falls below the trip point voltage,  $V_{TRIPF}$ . Setting the LVI enable in stop mode bit, LVISTOP, enables the LVI to operate in stop mode. Setting the LVI 5V or 3V trip point bit, LVI5OR3, enables  $V_{TRIPF}$  to be configured for 5V operation. Clearing the LVI5OR3 bit enables  $V_{TRIPF}$  to be configured for 3V operation. The actual trip points are shown in [Chapter 23 Electrical Specifications](#).

#### NOTE

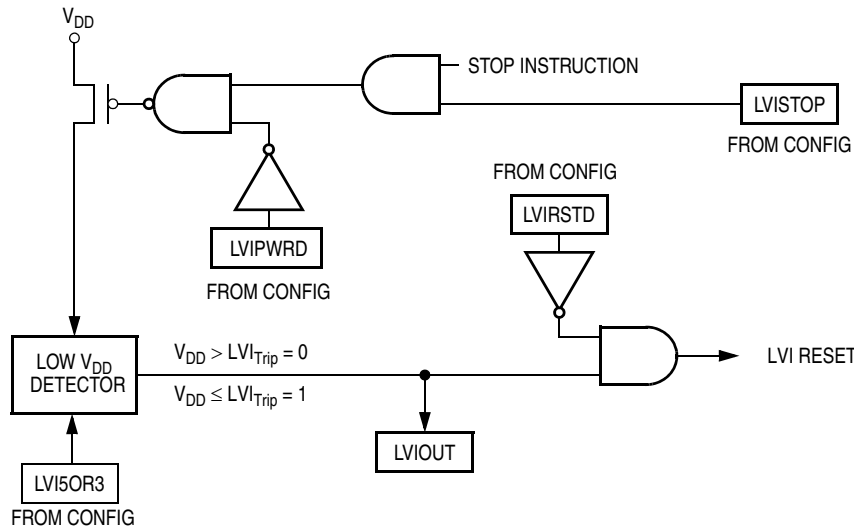
*After a power-on reset (POR) the LVI's default mode of operation is 3 V. If a 5V system is used, the user must set the LVI5OR3 bit to raise the trip point to 5V operation. Note that this must be done after every POR since the default will revert back to 3V mode after each POR. If the  $V_{DD}$  supply is below the 5V mode trip voltage but above the 3V mode trip voltage when POR is released, the part will operate because  $V_{TRIPF}$  defaults to 3V mode after a POR. So, in a 5V system care must be taken to ensure that  $V_{DD}$  is above the 5V mode trip voltage after POR is released.*

*If the user requires 5V mode and sets the LVI5OR3 bit after a POR while the  $V_{DD}$  supply is not above the  $V_{TRIPR}$  for 5V mode, the MCU will immediately go into reset. The LVI in this case will hold the part in reset until either  $V_{DD}$  goes above the rising 5V trip point,  $V_{TRIPR}$ , which will release reset or  $V_{DD}$  decreases to approximately 0 V which will re-trigger the POR and reset the trip point to 3V operation.*

## Low-Voltage Inhibit (LVI)

LVISTOP, LVIPWRD, LVI5OR3, and LVIRSTD are in the configuration register (CONFIG). See [Chapter 8 Configuration Register \(CONFIG\)](#) for details of the LVI's configuration bits. Once an LVI reset occurs, the MCU remains in reset until  $V_{DD}$  rises above a voltage,  $V_{TRIPR}$ , which causes the MCU to exit reset. See [19.3.2.5 Low-Voltage Inhibit \(LVI\) Reset](#) for details of the interaction between the SIM and the LVI. The output of the comparator controls the state of the LVIOUT flag in the LVI status register (LVISR).

An LVI reset also drives the  $\overline{RST}$  pin low to provide low-voltage protection to external peripheral devices.



**Figure 14-1. LVI Module Block Diagram**

Addr.	Register Name	Bit 7	6	5	4	3	2	1	Bit 0
\$FE0C	LVI Status Register (LVISR)	Read:	LVIOUT	0	0	0	0	0	0
		Write:							
		Reset:	0	0	0	0	0	0	0

□ = Unimplemented

**Figure 14-2. LVI I/O Register Summary**

### 14.3.1 Polled LVI Operation

In applications that can operate at  $V_{DD}$  levels below the  $V_{TRIPF}$  level, software can monitor  $V_{DD}$  by polling the LVIOUT bit. In the configuration register, the LVIPWRD bit must be 0 to enable the LVI module, and the LVIRSTD bit must be 1 to disable LVI resets.

### 14.3.2 Forced Reset Operation

In applications that require  $V_{DD}$  to remain above the  $V_{TRIPF}$  level, enabling LVI resets allows the LVI module to reset the MCU when  $V_{DD}$  falls below the  $V_{TRIPF}$  level. In the configuration register, the LVIPWRD and LVIRSTD bits must be cleared to enable the LVI module and to enable LVI resets.

### 14.3.3 Voltage Hysteresis Protection

Once the LVI has triggered (by having  $V_{DD}$  fall below  $V_{TRIPF}$ ), the LVI will maintain a reset condition until  $V_{DD}$  rises above the rising trip point voltage,  $V_{TRIPR}$ . This prevents a condition in which the MCU is continually entering and exiting reset if  $V_{DD}$  is approximately equal to  $V_{TRIPF}$ .  $V_{TRIPR}$  is greater than  $V_{TRIPF}$  by the hysteresis voltage,  $V_{HYS}$ .



### 14.3.4 LVI Trip Selection

The LVI5OR3 bit in the configuration register selects whether the LVI is configured for 5V or 3V protection.

#### NOTE

*The microcontroller is guaranteed to operate at a minimum supply voltage. The trip point ( $V_{TRIPF}$  [5 V] or  $V_{TRIPF}$  [3 V]) may be lower than this. (See Chapter 23 Electrical Specifications for the actual trip point voltages.)*

## 14.4 LVI Status Register

The LVI status register (LVISR) indicates if the  $V_{DD}$  voltage was detected below the  $V_{TRIPF}$  level.

Address: \$FE0C

	Bit 7	6	5	4	3	2	1	Bit 0
Read:	LVIOUT	0	0	0	0	0	0	0
Write:								
Reset:	0	0	0	0	0	0	0	0


 = Unimplemented

Figure 14-3. LVI Status Register (LVISR)

### LVIOUT — LVI Output Bit

This read-only flag becomes set when the  $V_{DD}$  voltage falls below the  $V_{TRIPF}$  trip voltage. See Table 14-1. Reset clears the LVIOUT bit.

Table 14-1. LVIOUT Bit Indication

$V_{DD}$	LVIOUT
$V_{DD} > V_{TRIPR}$	0
$V_{DD} < V_{TRIPF}$	1
$V_{TRIPF} < V_{DD} < V_{TRIPR}$	Previous value

## 14.5 LVI Interrupts

The LVI module does not generate interrupt requests.

## 14.6 Low-Power Modes

The STOP and WAIT instructions put the MCU in low power-consumption standby modes.

### 14.6.1 Wait Mode

If enabled, the LVI module remains active in wait mode. If enabled to generate resets, the LVI module can generate a reset and bring the MCU out of wait mode.

### 14.6.2 Stop Mode

If enabled in stop mode (LVISTOP bit in the configuration register is set), the LVI module remains active in stop mode. If enabled to generate resets, the LVI module can generate a reset and bring the MCU out of stop mode.



# Chapter 15

## Monitor ROM (MON)

### 15.1 Introduction

This section describes the monitor ROM (MON) and the monitor mode entry methods. The monitor ROM allows complete testing of the MCU through a single-wire interface with a host computer. Monitor mode entry can be achieved without use of the higher test voltage,  $V_{TST}$ , as long as vector addresses \$FFFE and \$FFFF are blank, thus reducing the hardware requirements for in-circuit programming.

### 15.2 Features

Features of the monitor ROM include:

- Normal user-mode pin functionality
- One pin dedicated to serial communication between monitor ROM and host computer
- Standard mark/space non-return-to-zero (NRZ) communication with host computer
- Execution of code in RAM or FLASH
- FLASH memory security feature<sup>(1)</sup>
- FLASH memory programming interface
- Enhanced PLL (phase-locked loop) option to allow use of external 32.768-kHz crystal to generate internal frequency of 2.4576 MHz
- 310 byte monitor ROM code size (\$FE20 to \$FF55)
- Monitor mode entry without high voltage,  $V_{TST}$ , if reset vector is blank (\$FFFE and \$FFFF contain \$FF)
- Standard monitor mode entry if high voltage,  $V_{TST}$ , is applied to  $\overline{IRQ}$

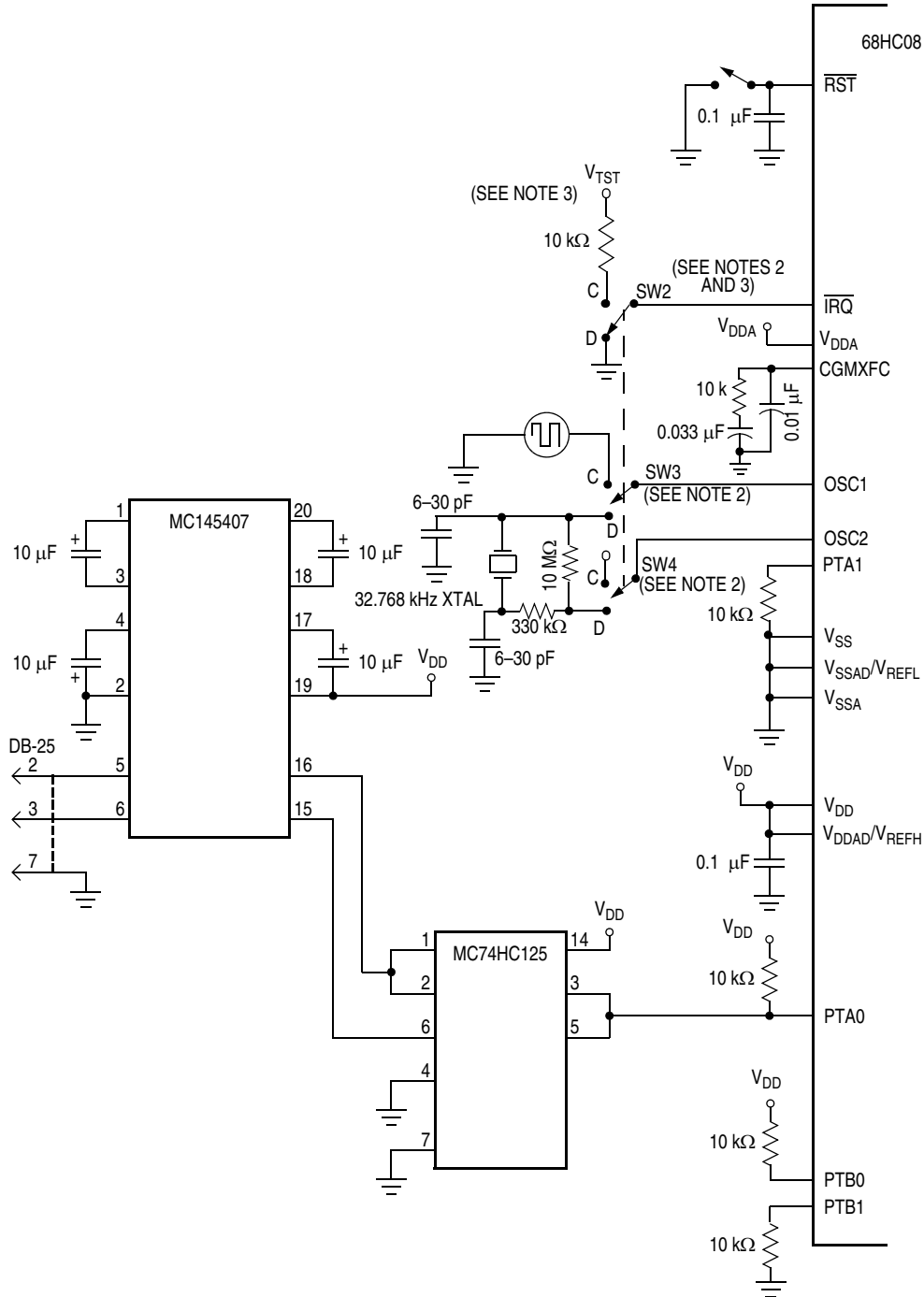
### 15.3 Functional Description

The monitor ROM receives and executes commands from a host computer. [Figure 15-1](#) shows an example circuit used to enter monitor mode and communicate with a host computer via a standard RS-232 interface.

Simple monitor commands can access any memory address. In monitor mode, the MCU can execute code downloaded into RAM by a host computer while most MCU pins retain normal operating mode functions. All communication between the host computer and the MCU is through the PTA0 pin. A level-shifting and multiplexing interface is required between PTA0 and the host computer. PTA0 is used in a wired-OR configuration and requires a pullup resistor.

---

1. No security feature is absolutely secure. However, Freescale's strategy is to make reading or copying the FLASH difficult for unauthorized users.



Notes:

1. SW2, SW3, and SW4: Position C — Enter monitor mode using external oscillator.  
SW2, SW3, and SW4: Position D — Enter monitor mode using external XTAL and internal PLL.
2. See [Table 15-1. Monitor Mode Signal Requirements and Options](#) for IRQ voltage level requirements.

Figure 15-1. Monitor Mode Circuit

The monitor code has been updated from previous versions to allow enabling the PLL to generate the internal clock, provided the reset vector is blank, when the device is being clocked by a low-frequency crystal. This addition, which is enabled when  $\overline{\text{IRQ}}$  is held low out of reset, is intended to support serial communication/ programming at 9600 baud in monitor mode by stepping up the external frequency (assumed to be 32.768 kHz) by a fixed amount to generate the desired internal frequency (2.4576 MHz). Since this feature is enabled only when  $\overline{\text{IRQ}}$  is held low out of reset, it cannot be used when the reset vector is not blank because entry into monitor mode in this case requires  $V_{\text{TST}}$  on  $\overline{\text{IRQ}}$ .

### 15.3.1 Entering Monitor Mode

Table 15-1 shows the pin conditions for entering monitor mode. As specified in the table, monitor mode may be entered after a power-on reset (POR) and will allow communication at 9600 baud provided one of the following sets of conditions is met:

1. If \$FFFE and \$FFFF contain values not cared:
  - The external clock is 9.8304 MHz
  - $\overline{\text{IRQ}} = V_{\text{TST}}$  (PLL off)
2. If \$FFFE and \$FFFF contain \$FF, blank state:
  - The external clock is 9.8304 MHz
  - $\overline{\text{IRQ}} = V_{\text{DD}}$  (this can be implemented through the internal  $\overline{\text{IRQ}}$  pullup; PLL off)
3. If \$FFFE and \$FFFF contain \$FF, blank state:
  - The external clock is 32.768 kHz (crystal)
  - $\overline{\text{IRQ}} = V_{\text{SS}}$  (this setting initiates the PLL to boost the external 32.768 kHz to an internal bus frequency of 2.4576 MHz)

If entering monitor mode with  $V_{\text{TST}}$  applied on  $\overline{\text{IRQ}}$  (condition set 1), the CGMOUT frequency is equal to the CGMXCLK frequency and the OSC1 input directly generates internal bus clocks. In this case, the OSC1 signal must have a 50% duty cycle at maximum bus frequency.

If entering monitor mode without high voltage applied on  $\overline{\text{IRQ}}$  (condition set 2 or 3, where applied voltage is either  $V_{\text{DD}}$  or  $V_{\text{SS}}$ ), then all port B pin requirements and conditions, are not in effect. This is to reduce circuit requirements when performing in-circuit programming.

#### NOTE

*If the reset vector is blank and monitor mode is entered, the chip will see an additional reset cycle after the initial POR reset. Once the part has been programmed, the traditional method of applying a voltage,  $V_{\text{TST}}$ , to  $\overline{\text{IRQ}}$  must be used to enter monitor mode.*

The COP module is disabled in monitor mode based on these conditions:

- If monitor mode was entered as a result of the reset vector being blank (condition set 2 or 3), the COP is always disabled regardless of the state of  $\overline{\text{IRQ}}$  or  $\overline{\text{RST}}$ .
- If monitor mode was entered with  $V_{\text{TST}}$  on  $\overline{\text{IRQ}}$  (condition set 1), then the COP is disabled as long as  $V_{\text{TST}}$  is applied to either  $\overline{\text{IRQ}}$  or  $\overline{\text{RST}}$ .

The second condition states that as long as  $V_{\text{TST}}$  is maintained on the  $\overline{\text{IRQ}}$  pin after entering monitor mode, or if  $V_{\text{TST}}$  is applied to  $\overline{\text{RST}}$  after the initial reset to get into monitor mode (when  $V_{\text{TST}}$  was applied to  $\overline{\text{IRQ}}$ ), then the COP will be disabled. In the latter situation, after  $V_{\text{TST}}$  is applied to the  $\overline{\text{RST}}$  pin,  $V_{\text{TST}}$  can be removed from the  $\overline{\text{IRQ}}$  pin in the interest of freeing the  $\overline{\text{IRQ}}$  for normal functionality in monitor mode.

**Table 15-1. Monitor Mode Signal Requirements and Options**

$\overline{\text{IRQ}}$	RESET	\$FFFF/ \$FFFF	PLL	PTB0	PTB1	External Clock <sup>(1)</sup>	CGMOUT	Bus Freq	COP	For Serial Communication			Comment
										PTA0	PTA1	Baud Rate <sup>(2) (3)</sup>	
X	GND	X	X	X	X	X	0	0	Disabled	X	X	0	No operation until reset goes high
$V_{\text{TST}}$	$V_{\text{DD}}$ or $V_{\text{TST}}$	X	OFF	1	0	9.8304 MHz	4.9152 MHz	2.4576 MHz	Disabled	1	0	9600	PTB0 and PTB1 voltages only required if $\overline{\text{IRQ}} = V_{\text{TST}}$
										X	1	DNA	
$V_{\text{DD}}$	$V_{\text{DD}}$	\$FFFF	OFF	X	X	9.8304 MHz	4.9152 MHz	2.4576 MHz	Disabled	1	0	9600	External frequency always divided by 4
										X	1	DNA	
GND	$V_{\text{DD}}$	\$FFFF	ON	X	X	32.768 kHz	4.9152 MHz	2.4576 MHz	Disabled	1	0	9600	PLL enabled (BCS set) in monitor code
										X	1	DNA	
$V_{\text{DD}}$ or GND	$V_{\text{TST}}$	\$FFFF	OFF	X	X	X	—	—	Enabled	X	X	—	Enters user mode — will encounter an illegal address reset
$V_{\text{DD}}$ or GND	$V_{\text{DD}}$ or $V_{\text{TST}}$	Not \$FFFF	OFF	X	X	X	—	—	Enabled	X	X	—	Enters user mode

1. External clock is derived by a 32.768 kHz crystal or a 9.8304 MHz off-chip oscillator
2. PTA0 = 1 if serial communication; PTA0 = X if parallel communication
3. PTA1 = 0 → serial, PTA1 = 1 → parallel communication for security code entry
4. DNA = does not apply, X = don't care

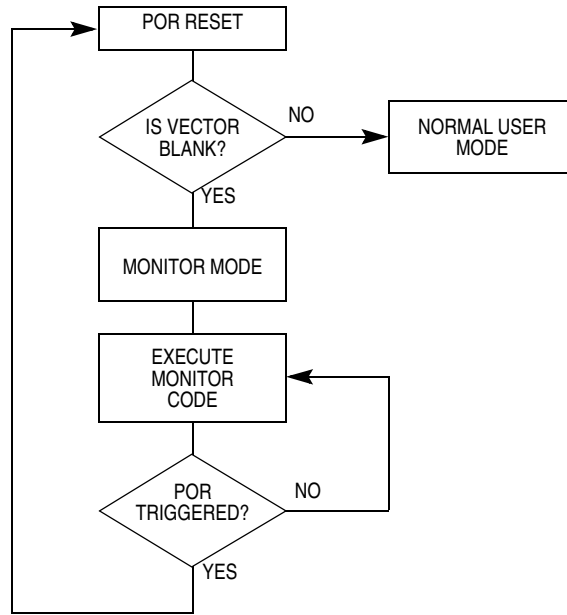
Figure 15-2 shows a simplified diagram of the monitor mode entry when the reset vector is blank and just  $1 \times V_{\text{DD}}$  voltage is applied to the  $\overline{\text{IRQ}}$  pin. An external oscillator of 9.8304 MHz is required for a baud rate of 9600, as the internal bus frequency is automatically set to the external frequency divided by four.

Enter monitor mode with pin configuration shown in Figure 15-1 by pulling  $\overline{\text{RST}}$  low and then high. The rising edge of  $\overline{\text{RST}}$  latches monitor mode. Once monitor mode is latched, the values on the specified pins can change.

Once out of reset, the MCU waits for the host to send eight security bytes. (See Security.) After the security bytes, the MCU sends a break signal (10 consecutive logic 0s) to the host, indicating that it is ready to receive a command.

**NOTE**

*The PTA1 pin must remain at logic 0 for 24 bus cycles after the  $\overline{\text{RST}}$  pin goes high to enter monitor mode properly.*



**Figure 15-2. Low-Voltage Monitor Mode Entry Flowchart**

In monitor mode, the MCU uses different vectors for reset, SWI (software interrupt), and break interrupt than those for user mode. The alternate vectors are in the \$FE page instead of the \$FF page and allow code execution from the internal monitor firmware instead of user code.

**NOTE**

*Exiting monitor mode after it has been initiated by having a blank reset vector requires a power-on reset. Pulling  $\overline{RST}$  low will not exit monitor mode in this situation.*

Table 15-2 summarizes the differences between user mode and monitor mode.

**Table 15-2. Mode Differences**

Modes	Functions					
	Reset Vector High	Reset Vector Low	Break Vector High	Break Vector Low	SWI Vector High	SWI Vector Low
User	\$FFFE	\$FFFF	\$FFFC	\$FFFD	\$FFFC	\$FFFD
Monitor	\$FEFE	\$FEFF	\$FEFC	\$FEFD	\$FEFC	\$FEFD

### 15.3.2 Data Format

Communication with the monitor ROM is in standard non-return-to-zero (NRZ) mark/space data format. Transmit and receive baud rates must be identical.

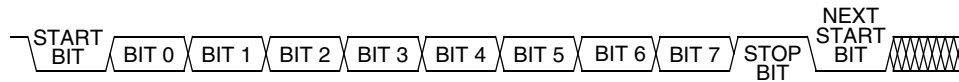


Figure 15-3. Monitor Data Format

### 15.3.3 Break Signal

A start bit (0) followed by nine 0 bits is a break signal. When the monitor receives a break signal, it drives the PTA0 pin high for the duration of two bits and then echoes back the break signal.

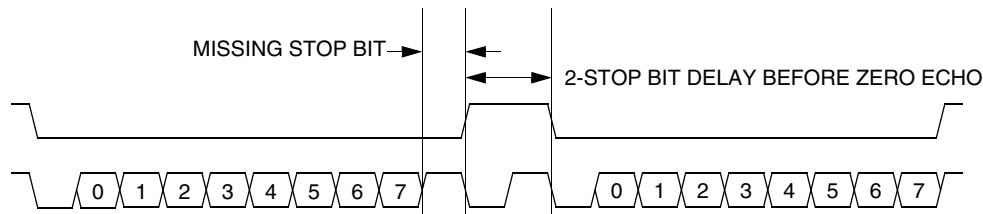


Figure 15-4. Break Transaction

### 15.3.4 Baud Rate

The communication baud rate is controlled by the crystal frequency upon entry into monitor mode. The divide by ratio is 1024.

If monitor mode was entered with  $V_{DD}$  on  $\overline{IRQ}$ , then the divide by ratio is also set at 1024. If monitor mode was entered with  $V_{SS}$  on  $\overline{IRQ}$ , then the internal PLL steps up the external frequency, presumed to be 32.768 kHz, to 2.4576 MHz. These latter two conditions for monitor mode entry require that the reset vector is blank.

Table 15-3 lists external frequencies required to achieve a standard baud rate of 9600 BPS. Other standard baud rates can be accomplished using proportionally higher or lower frequency generators. If using a crystal as the clock source, be aware of the upper frequency limit that the internal clock module can handle. See 23.6 5.0 V Control Timing and 23.7 3.0 V Control Timing for this limit.

Table 15-3. Monitor Baud Rate Selection

External Frequency	$\overline{IRQ}$	Internal Frequency	Baud Rate (BPS)
9.8304 MHz	$V_{TST}$	2.4576 MHz	9600
9.8304 MHz	$V_{DD}$	2.4576 MHz	9600
32.768 kHz	$V_{SS}$	2.4576 MHz	9600



### 15.3.5 Commands

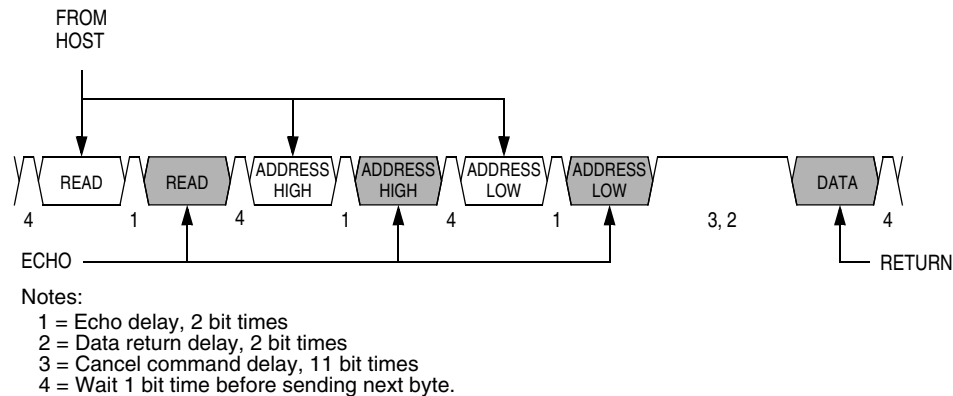
The monitor ROM firmware uses these commands:

- READ (read memory)
- WRITE (write memory)
- IREAD (indexed read)
- IWRITE (indexed write)
- READSP (read stack pointer)
- RUN (run user program)

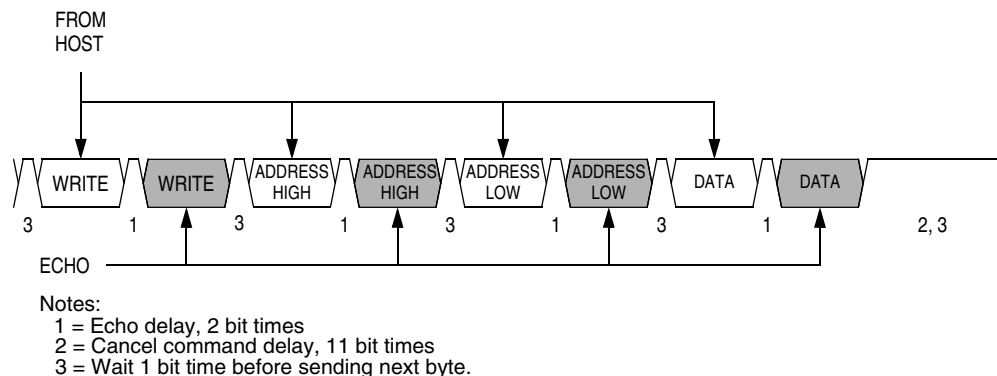
The monitor ROM firmware echoes each received byte back to the PTA0 pin for error checking. An 11-bit delay at the end of each command allows the host to send a break character to cancel the command. A delay of two bit times occurs before each echo and before READ, IREAD, or READSP data is returned. The data returned by a read command appears after the echo of the last byte of the command.

#### NOTE

*Wait one bit time after each echo before sending the next byte.*



**Figure 15-5. Read Transaction**



**Figure 15-6. Write Transaction**

## Monitor ROM (MON)

A brief description of each monitor mode command is given in [Table 15-4](#) through [Table 15-9](#).

**Table 15-4. READ (Read Memory) Command**

<b>Description</b>	Read byte from memory
<b>Operand</b>	2-byte address in high-byte:low-byte order
<b>Data Returned</b>	Returns contents of specified address
<b>Opcode</b>	\$4A
<b>Command Sequence</b>	

**Table 15-5. WRITE (Write Memory) Command**

<b>Description</b>	Write byte to memory
<b>Operand</b>	2-byte address in high-byte:low-byte order; low byte followed by data byte
<b>Data Returned</b>	None
<b>Opcode</b>	\$49
<b>Command Sequence</b>	

**Table 15-6. IREAD (Indexed Read) Command**

<b>Description</b>	Read next 2 bytes in memory from last address accessed
<b>Operand</b>	2-byte address in high byte:low byte order
<b>Data Returned</b>	Returns contents of next two addresses
<b>Opcode</b>	\$1A
<b>Command Sequence</b>	

**Table 15-7. IWRITE (Indexed Write) Command**

<b>Description</b>	Write to last address accessed + 1
<b>Operand</b>	Single data byte
<b>Data Returned</b>	None
<b>Opcode</b>	\$19
<b>Command Sequence</b>	

A sequence of IREAD or IWRITE commands can access a block of memory sequentially over the full 64K byte memory map.

**Table 15-8. READSP (Read Stack Pointer) Command**

<b>Description</b>	Reads stack pointer
<b>Operand</b>	None
<b>Data Returned</b>	Returns incremented stack pointer value (SP + 1) in high-byte:low-byte order
<b>Opcode</b>	\$0C
<b>Command Sequence</b>	

**Table 15-9. RUN (Run User Program) Command**

<b>Description</b>	Executes PULH and RTI instructions
<b>Operand</b>	None
<b>Data Returned</b>	None
<b>Opcode</b>	\$28
<b>Command Sequence</b>	

## Monitor ROM (MON)

The MCU executes the SWI and PSHH instructions when it enters monitor mode. The RUN command tells the MCU to execute the PULH and RTI instructions. Before sending the RUN command, the host can modify the stacked CPU registers to prepare to run the host program. The READSP command returns the incremented stack pointer value, SP + 1. The high and low bytes of the program counter are at addresses SP + 5 and SP + 6.

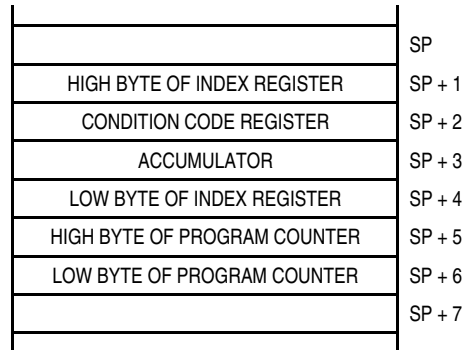


Figure 15-7. Stack Pointer at Monitor Mode Entry

## 15.4 Security

A security feature discourages unauthorized reading of FLASH locations while in monitor mode. The host can bypass the security feature at monitor mode entry by sending eight security bytes that match the bytes at locations \$FFF6–\$FFFD. Locations \$FFF6–\$FFFD contain user-defined data.

### NOTE

*Do not leave locations \$FFF6–\$FFFD blank. For security reasons, they should be programmed even if they are not used for vectors.*

During monitor mode entry, the MCU waits after the power-on reset for the host to send the eight security bytes on pin PTA0. If the received bytes match those at locations \$FFF6–\$FFFD, the host bypasses the security feature and can read all FLASH locations and execute code from FLASH. Security remains bypassed until a power-on reset occurs. If the reset was not a power-on reset, security remains bypassed and security code entry is not required. (See [Figure 15-8](#).)

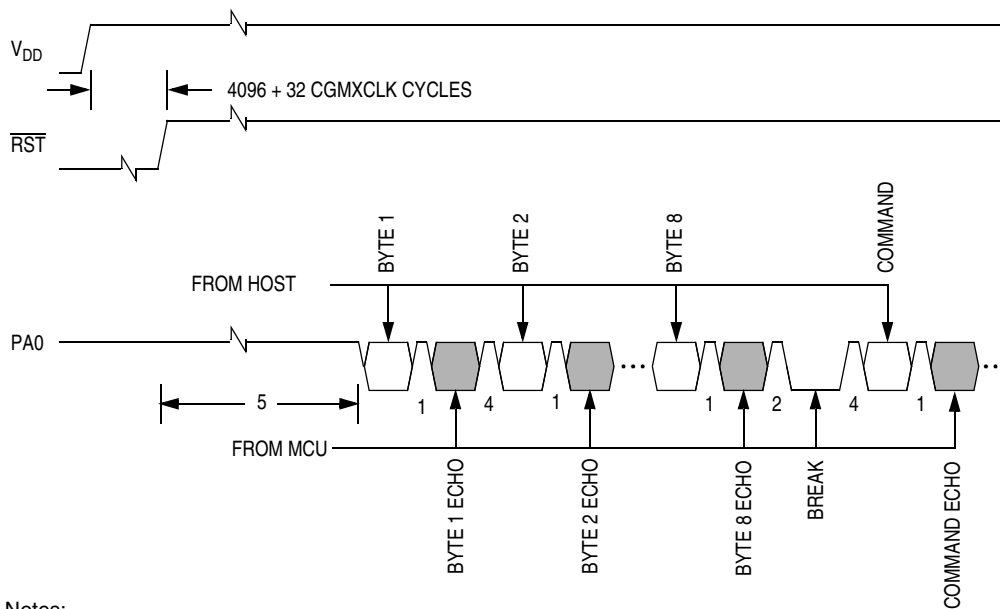
Upon power-on reset, if the received bytes of the security code do not match the data at locations \$FFF6–\$FFFD, the host fails to bypass the security feature. The MCU remains in monitor mode, but reading a FLASH location returns an invalid value and trying to execute code from FLASH causes an illegal address reset. After receiving the eight security bytes from the host, the MCU transmits a break character, signifying that it is ready to receive a command.

### NOTE

*The MCU does not transmit a break character until after the host sends the eight security bytes.*

To determine whether the security code entered is correct, check to see if bit 6 of RAM address \$40 is set. If it is, then the correct security code has been entered and FLASH can be accessed.

If the security sequence fails, the device can be reset by a power-on reset and brought up in monitor mode to attempt another entry. After failing the security sequence, the FLASH mode can also be bulk erased by executing an erase routine that was downloaded into internal RAM. The bulk erase operation clears the security code locations so that all eight security bytes become \$FF (blank).



- Notes:
- 1 = Echo delay, approximately 2 bit times
  - 2 = Data return delay, approximately 2 bit times
  - 4 = Wait 1 bit time before sending next byte
  - 5 = Wait until the monitor ROM runs

**Figure 15-8. Monitor Mode Entry Timing**



# Chapter 16

## Input/Output Ports (I/O)

### 16.1 Introduction

Twenty one (21) bidirectional input-output (I/O) pins form five parallel ports. All I/O pins are programmable as inputs or outputs. All individual bits within port A, port C, and port D are software configurable with pullup devices if configured as input port bits. The pullup devices are automatically and dynamically disabled when a port bit is switched to output mode.

**NOTE**

*Connect any unused I/O pins to an appropriate logic level, either  $V_{DD}$  or  $V_{SS}$ . Although the I/O ports do not require termination for proper operation, termination reduces excess current consumption and the possibility of electrostatic damage. Not all port pins are bonded out in all packages. Care should be taken to make any unbonded port pins an output to prevent them from being floating inputs.*


Addr.	Register Name	Bit 7	6	5	4	3	2	1	Bit 0	
\$0000	Port A Data Register (PTA)	Read:	0	0	0	0	PTA3	PTA2	PTA1	PTA0
		Write:								
		Reset:	Unaffected by reset							
\$0001	Port B Data Register (PTB)	Read:	0	0	PTB5	PTB4	PTB3	PTB2	PTB1	PTB0
		Write:								
		Reset:	Unaffected by reset							
\$0002	Port C Data Register (PTC)	Read:	0	0	0	0	0	0	PTC1	PTC0
		Write:								
		Reset:	Unaffected by reset							
\$0003	Port D Data Register (PTD)	Read:	0	PTD6	PTD5	PTD4	PTD3	PTD2	PTD1	PTD0
		Write:								
		Reset:	Unaffected by reset							
\$0004	Data Direction Register A (DDRA)	Read:	0	0	0	0	DDRA3	DDRA2	DDRA1	DDRA0
		Write:								
		Reset:	0	0	0	0	0	0	0	0

= Unimplemented

**Figure 16-1. I/O Port Register Summary**

## Input/Output Ports (I/O)

Addr.	Register Name	Bit 7	6	5	4	3	2	1	Bit 0	
\$0005	Data Direction Register B (DDRB)	Read:	0	0	DDRB5	DDRB4	DDRB3	DDRB2	DDRB1	DDRB0
		Write:								
		Reset:	0	0	0	0	0	0	0	0
\$0006	Data Direction Register C (DDRC)	Read:	0	0	0	0	0	0	DDRC1	DDRC0
		Write:								
		Reset:	0	0	0	0	0	0	0	0
\$0007	Data Direction Register D (DDR D)	Read:	0	DDR D6	DDR D5	DDR D4	DDR D3	DDR D2	DDR D1	DDR D0
		Write:								
		Reset:	0	0	0	0	0	0	0	0
\$0008	Port E Data Register (PTE)	Read:	0	0	0	0	0	0	PTE1	PTE0
		Write:								
		Reset:	Unaffected by reset							
\$000C	Data Direction Register E (DDRE)	Read:	0	0	0	0	0	0	DDRE1	DDRE0
		Write:								
		Reset:	0	0	0	0	0	0	0	0
\$000D	Port A Input Pullup Enable Register (PTAPUE)	Read:	0	0	0	0	PTAPUE3	PTAPUE2	PTAPUE1	PTAPUE0
		Write:								
		Reset:	0	0	0	0	0	0	0	0
\$000E	Port C Input Pullup Enable Register (PTCPUE)	Read:	0	0	0	0	0	0	PTCPUE1	PTCPUE0
		Write:								
		Reset:	0	0	0	0	0	0	0	0
\$000F	Port D Input Pullup Enable Register (PTDPUE)	Read:	0	PTDPUE6	PTDPUE5	PTDPUE4	PTDPUE3	PTDPUE2	PTDPUE1	PTDPUE0
		Write:								
		Reset:	0	0	0	0	0	0	0	0

 = Unimplemented

**Figure 16-1. I/O Port Register Summary (Continued)**



Table 16-1. Port Control Register Bits Summary

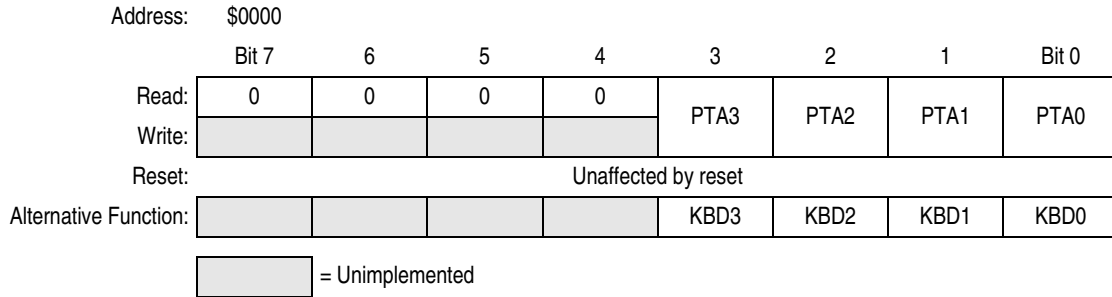
Port	Bit	DDR	Module Control		Pin
A	0	DDRA0	KBD	KBIE0	PTA0/KBD0
	1	DDRA1		KBIE1	PTA1/KBD1
	2	DDRA2		KBIE2	PTA2/KBD2
	3	DDRA3		KBIE3	PTA3/KBD3
	—	—		—	—
	—	—		—	—
	—	—		—	—
	—	—		—	—
B	0	DDRB0	ADC	CH0	PTB0/ATD0
	1	DDRB1		CH1	PTB1/ATD1
	2	DDRB2		CH2	PTB2/ATD2
	3	DDRB3		CH3	PTB3/ATD3
	4	DDRB4		CH4	PTB4/ATD4
	5	DDRB5		CH5	PTB5/ATD5
	—	—		—	—
	—	—		—	—
C	0	DDRC0			PTC0
	1	DDRC1			PTC1
	—	—			—
	—	—			—
	—	—			—
	—	—			—
	—	—			—
D	0	DDRD0	SPI	SPE	PTD0/ $\overline{SS}$
	1	DDRD1			PTD1/MISO
	2	DDRD2			PTD2/MOSI
	3	DDRD3			PTD3/SPSCK
	4	DDRD4	TIM1	ELS0B:ELS0A	PTD4/T1CH0
	5	DDRD5		ELS1B:ELS1A	PTD5/T1CH1
	6	DDRD6	TIM2	ELS0B:ELS0A	PTD6/T2CH0
	—	—		—	—
E	0	DDRE0	SCI	ENSCI	PTE0/TxD
	1	DDRE1			PTE1/RxD

## 16.2 Port A

Port A is an 4-bit special-function port that shares all four of its pins with the keyboard interrupt (KBI) module. Port A also has software configurable pullup devices if configured as an input port.

### 16.2.1 Port A Data Register

The port A data register (PTA) contains a data latch for each of the four port A pins.



**Figure 16-2. Port A Data Register (PTA)**

#### PTA3–PTA0 — Port A Data Bits

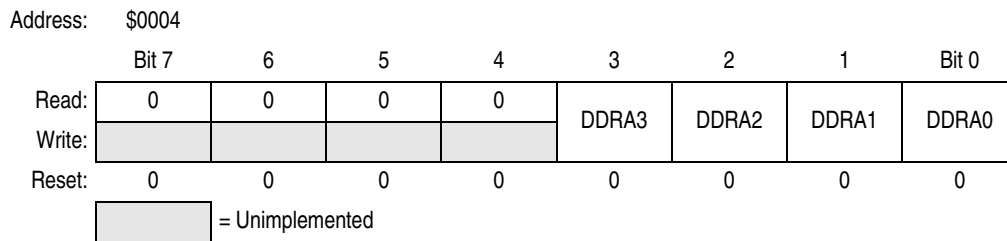
These read/write bits are software programmable. Data direction of each port A pin is under the control of the corresponding bit in data direction register A. Reset has no effect on port A data.

#### KBD3–KBD0 — Keyboard Inputs

The keyboard interrupt enable bits, KBIE3–KBIE0, in the keyboard interrupt control register (KBICR) enable the port A pins as external interrupt pins. See [Chapter 13 Keyboard Interrupt \(KBI\)](#).

### 16.2.2 Data Direction Register A

Data direction register A (DDRA) determines whether each port A pin is an input or an output. Writing a 1 to a DDRA bit enables the output buffer for the corresponding port A pin; a 0 disables the output buffer.



**Figure 16-3. Data Direction Register A (DDRA)**

#### DDRA3–DDRA0 — Data Direction Register A Bits

These read/write bits control port A data direction. Reset clears DDRA3–DDRA0, configuring all port A pins as inputs.

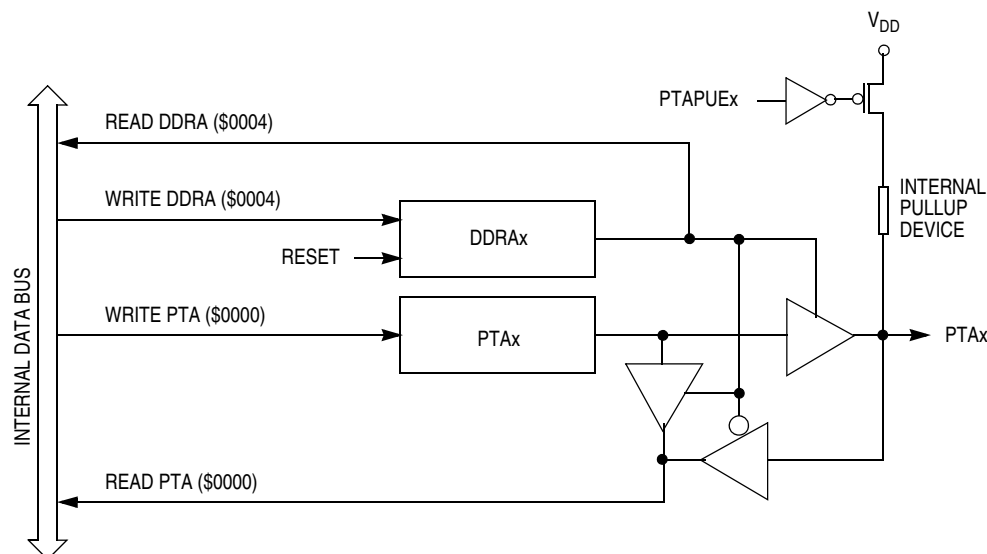
1 = Corresponding port A pin configured as output

0 = Corresponding port A pin configured as input

**NOTE**

*Avoid glitches on port A pins by writing to the port A data register before changing data direction register A bits from 0 to 1.*

Figure 16-4 shows the port A I/O logic.



**Figure 16-4. Port A I/O Circuit**

When bit DDRA<sub>x</sub> is a 1, reading address \$0000 reads the PTAx data latch. When bit DDRA<sub>x</sub> is a 0, reading address \$0000 reads the voltage level on the pin. The data latch can always be written, regardless of the state of its data direction bit. [Table 16-2](#) summarizes the operation of the port A pins.

**Table 16-2. Port A Pin Functions**

PTAPUE Bit	DDRA Bit	PTA Bit	I/O Pin Mode	Accesses to DDRA		Accesses to PTA	
				Read/Write	Read	Write	
1	0	X <sup>(1)</sup>	Input, V <sub>DD</sub> <sup>(4)</sup>	DDRA3–DDRA0	Pin	PTA3–PTA0 <sup>(3)</sup>	
0	0	X	Input, Hi-Z <sup>(2)</sup>	DDRA3–DDRA0	Pin	PTA3–PTA0 <sup>(3)</sup>	
X	1	X	Output	DDRA3–DDRA0	PTA3–PTA0		PTA3–PTA0

**NOTES:**

1. X = Don't care
2. Hi-Z = High impedance
3. Writing affects data register, but does not affect input.
4. I/O pin pulled up to V<sub>DD</sub> by internal pullup device


### 16.2.3 Port A Input Pullup Enable Register

The port A input pullup enable register (PTAPUE) contains a software configurable pullup device for each of the four port A pins. Each bit is individually configurable and requires that the data direction register, DDRA, bit be configured as an input. Each pullup is automatically and dynamically disabled when a port bit's DDRA is configured for output mode.

## Input/Output Ports (I/O)

Address: \$000D

	Bit 7	6	5	4	3	2	1	Bit 0
Read:	0	0	0	0	PTAPUE3	PTAPUE2	PTAPUE1	PTAPUE0
Write:								
Reset:	0	0	0	0	0	0	0	0

 = Unimplemented

**Figure 16-5. Port A Input Pullup Enable Register (PTAPUE)**

### PTAPUE3–PTAPUE0 — Port A Input Pullup Enable Bits

These writable bits are software programmable to enable pullup devices on an input port bit.

1 = Corresponding port A pin configured to have internal pullup

0 = Corresponding port A pin has internal pullup disconnected

## 16.3 Port B


Port B is a 6-bit special-function port that shares all six of its pins with the analog-to-digital converter (ADC) module.

### 16.3.1 Port B Data Register

The port B data register (PTB) contains a data latch for each of the six port pins.

Address: \$0001

	Bit 7	6	5	4	3	2	1	Bit 0
Read:	0	0	PTB5	PTB4	PTB3	PTB2	PTB1	PTB0
Write:								
Reset:	Unaffected by reset							
Alternative Function:			AD5	AD4	AD3	AD2	AD1	AD0

 = Unimplemented

**Figure 16-6. Port B Data Register (PTB)**

### PTB5–PTB0 — Port B Data Bits

These read/write bits are software-programmable. Data direction of each port B pin is under the control of the corresponding bit in data direction register B. Reset has no effect on port B data.

### AD5–AD0 — Analog-to-Digital Input Bits

AD5–AD0 are pins used for the input channels to the analog-to-digital converter module. The channel select bits in the ADC status and control register define which port B pin will be used as an ADC input and overrides any control from the port I/O logic by forcing that pin as the input to the analog circuitry.

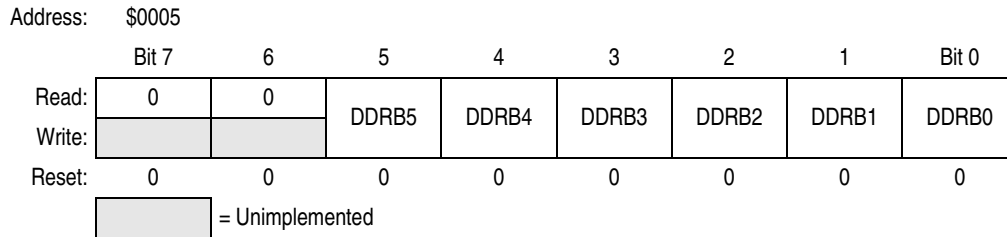
#### **NOTE**

*Care must be taken when reading port B while applying analog voltages to AD5–AD0 pins. If the appropriate ADC channel is not enabled, excessive current drain may occur if analog voltages are applied to the PTBx/ADx pin, while PTB is read as a digital input. Those ports not selected as analog input channels are considered digital I/O ports.*

*PTB4 and 5 are not available in a 28-pin DIP and SOIC package*

### 16.3.2 Data Direction Register B

Data direction register B (DDRB) determines whether each port B pin is an input or an output. Writing a 1 to a DDRB bit enables the output buffer for the corresponding port B pin; a 0 disables the output buffer.



**Figure 16-7. Data Direction Register B (DDRB)**

#### DDRB5–DDRB0 — Data Direction Register B Bits

These read/write bits control port B data direction. Reset clears DDRB5–DDRB0], configuring all port B pins as inputs.

- 1 = Corresponding port B pin configured as output
- 0 = Corresponding port B pin configured as input

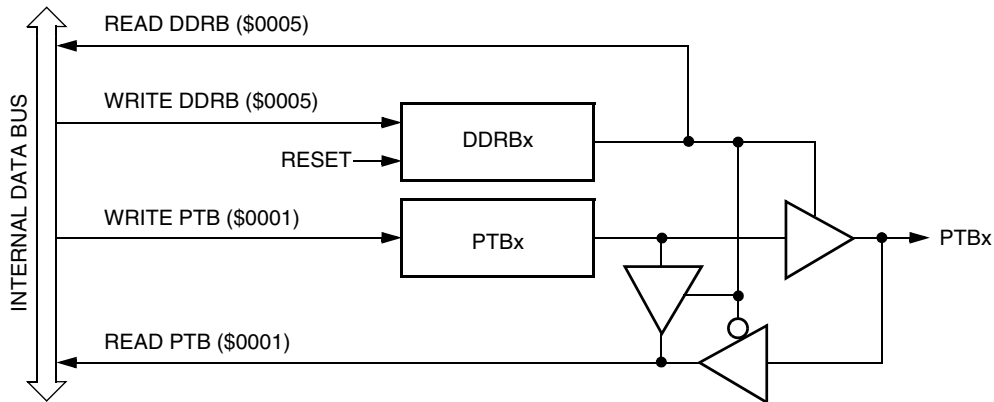
**NOTE**

*Avoid glitches on port B pins by writing to the port B data register before changing data direction register B bits from 0 to 1.*

**NOTE**

*For those devices packaged in a 28-pin DIP and SOIC package, PTB5,4 are not connected. Set DDRB5,4 to a 1 to configure PTB5,4 as outputs.*

Figure 16-8 shows the port B I/O logic.



**Figure 16-8. Port B I/O Circuit**

When bit DDRBx is a 1, reading address \$0001 reads the PTBx data latch. When bit DDRBx is a 0, reading address \$0001 reads the voltage level on the pin. The data latch can always be written, regardless of the state of its data direction bit. Table 16-3 summarizes the operation of the port B pins.

**Table 16-3. Port B Pin Functions**

DDRB Bit	PTB Bit	I/O Pin Mode	Accesses to DDRB	Accesses to PTB	
			Read/Write	Read	Write
0	X <sup>(1)</sup>	Input, Hi-Z <sup>(2)</sup>	DDRB5–DDRB0	Pin	PTB5–PTB0 <sup>(3)</sup>
1	X	Output	DDRB5–DDRB0	PTB5–PTB0	PTB5–PTB0

Notes:

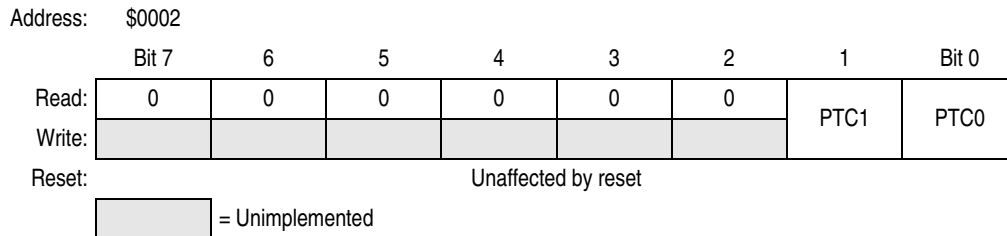
1. X = Don't care
2. Hi-Z = High impedance
3. Writing affects data register, but does not affect input.

## 16.4 Port C

Port C is a 2-bit, general-purpose bidirectional I/O port. Port C also has software configurable pullup devices if configured as an input port.

### 16.4.1 Port C Data Register

The port C data register (PTC) contains a data latch for each of the two port C pins.



**Figure 16-9. Port C Data Register (PTC)**

### PTC1–PTC0 — Port C Data Bits

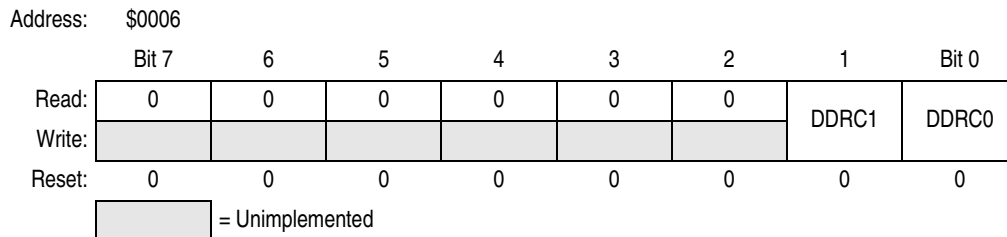
These read/write bits are software-programmable. Data direction of each port C pin is under the control of the corresponding bit in data direction register C. Reset has no effect on port C data.

**NOTE**

*PTC is not available in a 28-pin DIP and SOIC package*

### 16.4.2 Data Direction Register C

Data direction register C (DDRC) determines whether each port C pin is an input or an output. Writing a 1 to a DDRC bit enables the output buffer for the corresponding port C pin; a 0 disables the output buffer.



**Figure 16-10. Data Direction Register C (DDRC)**

### DDRC1–DDRC0 — Data Direction Register C Bits

These read/write bits control port C data direction. Reset clears DDRC1–DDRC0, configuring all port C pins as inputs.

1 = Corresponding port C pin configured as output

0 = Corresponding port C pin configured as input

#### NOTE

Avoid glitches on port C pins by writing to the port C data register before changing data direction register C bits from 0 to 1.

Figure 16-11 shows the port C I/O logic.

#### NOTE

For those devices packaged in a 28-pin DIP and SOIC package, PTC1,0 are not connected. Set DDRC1,0 to a 1 to configure PTC1,0 as outputs.

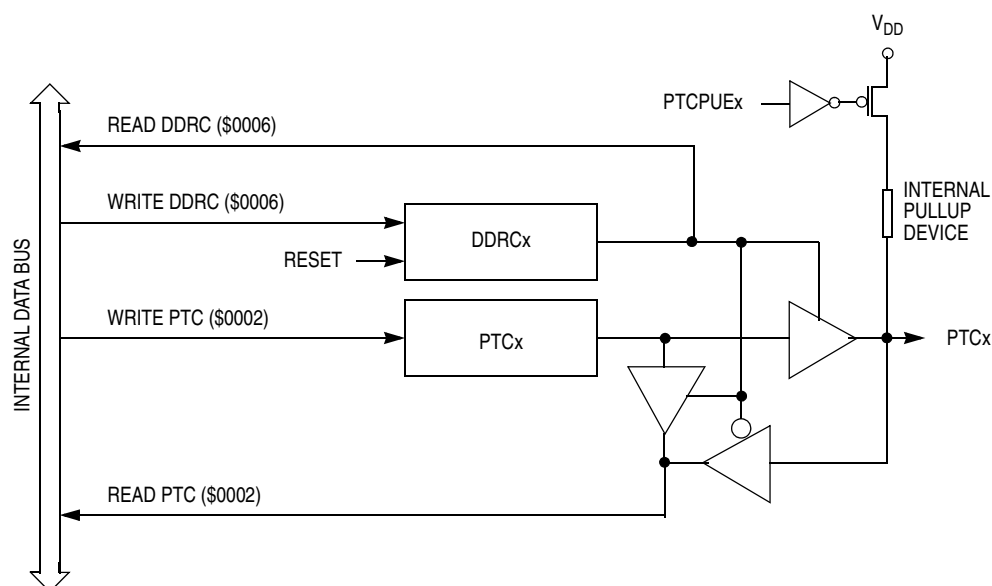


Figure 16-11. Port C I/O Circuit

When bit DDRCx is a 1, reading address \$0002 reads the PTCx data latch. When bit DDRCx is a 0, reading address \$0002 reads the voltage level on the pin. The data latch can always be written, regardless of the state of its data direction bit. Table 16-4 summarizes the operation of the port C pins.

Table 16-4. Port C Pin Functions

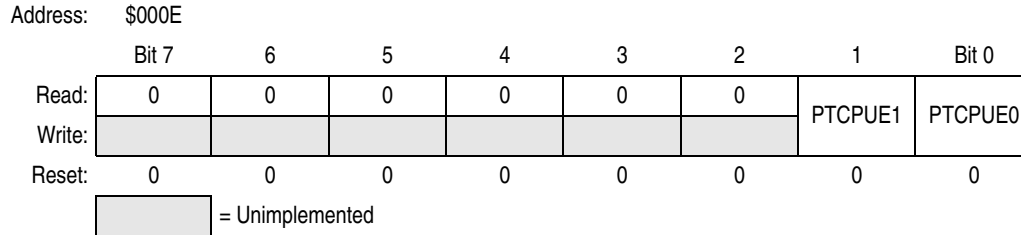
PTCPUE Bit	DDRC Bit	PTC Bit	I/O Pin Mode	Accesses to DDRC	Accesses to PTC	
				Read/Write	Read	Write
1	0	X <sup>(1)</sup>	Input, V <sub>DD</sub> <sup>(4)</sup>	DDRC1–DDRC0	Pin	PTC1–PTC0 <sup>(3)</sup>
0	0	X	Input, Hi-Z <sup>(2)</sup>	DDRC1–DDRC0	Pin	PTC1–PTC0 <sup>(3)</sup>
X	1	X	Output	DDRC1–DDRC0	PTC1–PTC0	PTC1–PTC0

Notes:

1. X = Don't care
2. Hi-Z = High impedance
3. Writing affects data register, but does not affect input.
4. I/O pin pulled up to V<sub>DD</sub> by internal pullup device.

### 16.4.3 Port C Input Pullup Enable Register

The port C input pullup enable register (PTCPUE) contains a software configurable pullup device for each of the two port C pins. Each bit is individually configurable and requires that the data direction register, DDRC, bit be configured as an input. Each pullup is automatically and dynamically disabled when a port bit's DDRC is configured for output mode.



**Figure 16-12. Port C Input Pullup Enable Register (PTCPUE)**

#### PTCPUE1–PTCPUE0 — Port C Input Pullup Enable Bits

These writeable bits are software programmable to enable pullup devices on an input port bit.

1 = Corresponding port C pin configured to have internal pullup

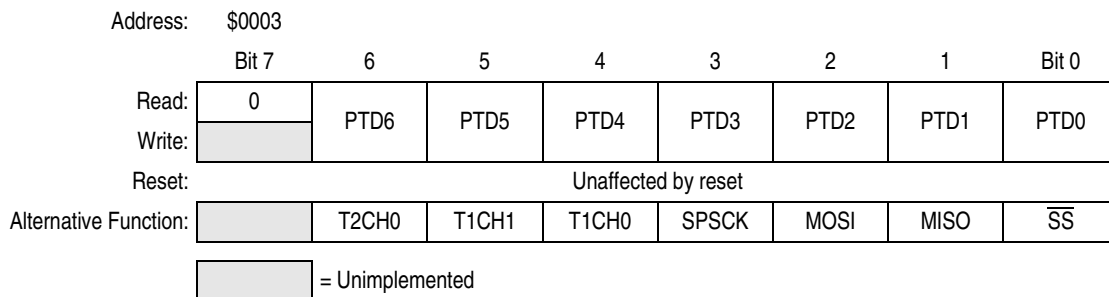
0 = Corresponding port C pin internal pullup disconnected

## 16.5 Port D

Port D is an 7-bit special-function port that shares four of its pins with the serial peripheral interface (SPI) module and three of its pins with two timer interface (TIM1 and TIM2) modules. Port D also has software configurable pullup devices if configured as an input port.

### 16.5.1 Port D Data Register

The port D data register (PTD) contains a data latch for each of the seven port D pins.



**Figure 16-13. Port D Data Register (PTD)**

#### PTD6–PTD0 — Port D Data Bits

These read/write bits are software-programmable. Data direction of each port D pin is under the control of the corresponding bit in data direction register D. Reset has no effect on port D data.

#### T2CH0 — Timer 2 Channel I/O Bits

The PTD6/T2CH0 pin is the TIM2 input capture/output compare pin. The edge/level select bits, ELSxB:ELSxA, determine whether the PTD6/T2CH0 pin is a timer channel I/O pin or a general-purpose I/O pin. See [Chapter 22 Timer Interface Module \(TIM\)](#).



### T1CH1 and T1CH0 — Timer 1 Channel I/O Bits

The PTD5/T1CH1–PTD4/T1CH0 pins are the TIM1 input capture/output compare pins. The edge/level select bits, ELSxB and ELSxA, determine whether the PTD5/T1CH1–PTD4/T1CH0 pins are timer channel I/O pins or general-purpose I/O pins. See [Chapter 22 Timer Interface Module \(TIM\)](#).

### SPSCK — SPI Serial Clock

The PTD3/SPSCK pin is the serial clock input of the SPI module. When the SPE bit is clear, the PTD3/SPSCK pin is available for general-purpose I/O.

### MOSI — Master Out/Slave In

The PTD2/MOSI pin is the master out/slave in terminal of the SPI module. When the SPE bit is clear, the PTD2/MOSI pin is available for general-purpose I/O.

### MISO — Master In/Slave Out

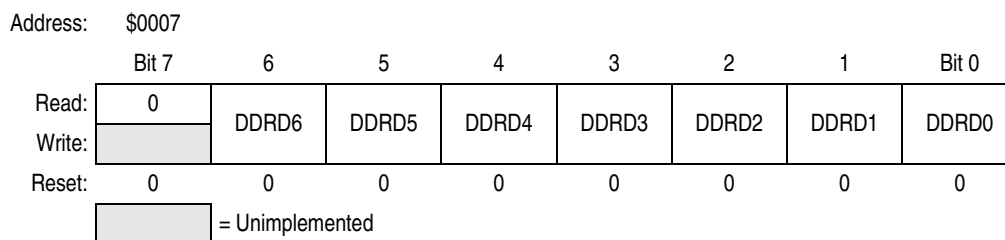
The PTD1/MISO pin is the master in/slave out terminal of the SPI module. When the SPI enable bit, SPE, is clear, the SPI module is disabled, and the PTD0/ $\overline{SS}$  pin is available for general-purpose I/O. Data direction register D (DDRD) does not affect the data direction of port D pins that are being used by the SPI module. However, the DDRD bits always determine whether reading port D returns the states of the latches or the states of the pins. See [Table 16-5](#).

### $\overline{SS}$ — Slave Select

The PTD0/ $\overline{SS}$  pin is the slave select input of the SPI module. When the SPE bit is clear, or when the SPI master bit, SPMSTR, is set, the PTD0/ $\overline{SS}$  pin is available for general-purpose I/O. When the SPI is enabled, the DDRB0 bit in data direction register B (DDRB) has no effect on the PTD0/ $\overline{SS}$  pin.

## 16.5.2 Data Direction Register D

Data direction register D (DDRD) determines whether each port D pin is an input or an output. Writing a 1 to a DDRD bit enables the output buffer for the corresponding port D pin; a 0 disables the output buffer.



**Figure 16-14. Data Direction Register D (DDRD)**

### DDRD6–DDRD0 — Data Direction Register D Bits

These read/write bits control port D data direction. Reset clears DDRD6–DDRD0, configuring all port D pins as inputs.

- 1 = Corresponding port D pin configured as output
- 0 = Corresponding port D pin configured as input

#### **NOTE**

*Avoid glitches on port D pins by writing to the port D data register before changing data direction register D bits from 0 to 1.*

Figure 16-15 shows the port D I/O logic.

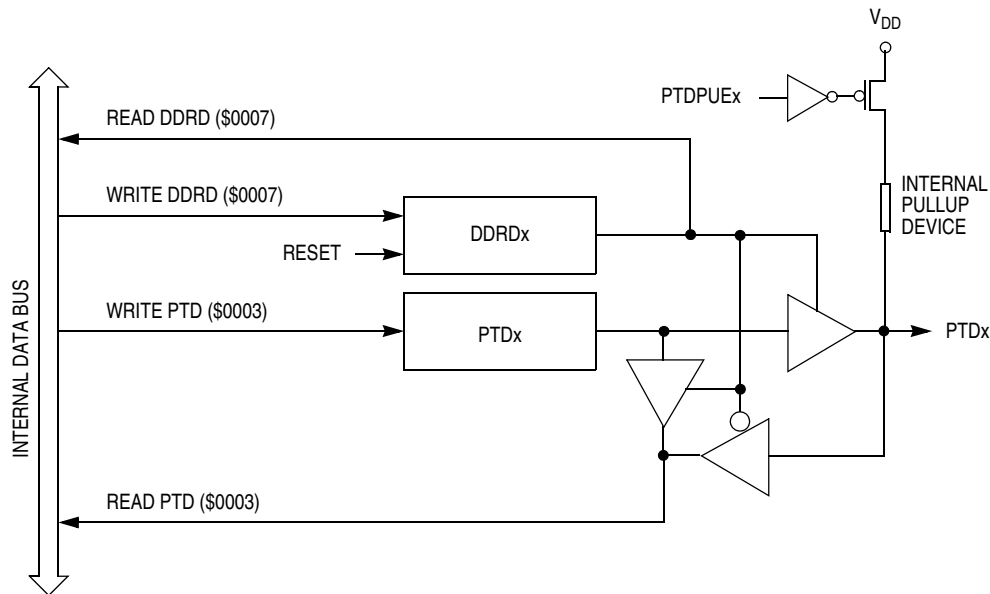


Figure 16-15. Port D I/O Circuit

When bit DDRDx is a 1, reading address \$0003 reads the PTDx data latch. When bit DDRDx is a 0, reading address \$0003 reads the voltage level on the pin. The data latch can always be written, regardless of the state of its data direction bit. Table 16-5 summarizes the operation of the port D pins.

Table 16-5. Port D Pin Functions

PTDPUEx Bit	DDRDx Bit	PTDx Bit	I/O Pin Mode	Accesses to DDRD	Accesses to PTD	
				Read/Write	Read	Write
1	0	X <sup>(1)</sup>	Input, V <sub>DD</sub> <sup>(4)</sup>	DDRD6–DDRD0	Pin	PTD6–PTD0 <sup>(3)</sup>
0	0	X	Input, Hi-Z <sup>(2)</sup>	DDRD6–DDRD0	Pin	PTD6–PTD0 <sup>(3)</sup>
X	1	X	Output	DDRD6–DDRD0	PTD6–PTD0	PTD6–PTD0

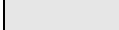
1. X = Don't care
2. Hi-Z = High impedance
3. Writing affects data register, but does not affect input.
4. I/O pin pulled up to V<sub>DD</sub> by internal pullup device.

### 16.5.3 Port D Input Pullup Enable Register

The port D input pullup enable register (PTDPUE) contains a software configurable pullup device for each of the seven port D pins. Each bit is individually configurable and requires that the data direction register, DDRD, bit be configured as an input. Each pullup is automatically and dynamically disabled when a port bit's DDRD is configured for output mode.

Address: \$000F

	Bit 7	6	5	4	3	2	1	Bit 0
Read:	0	PTDPUE6	PTDPUE5	PTDPUE4	PTDPUE3	PTDPUE2	PTDPUE1	PTDPUE0
Write:								
Reset:	0	0	0	0	0	0	0	0

 = Unimplemented

**Figure 16-16. Port D Input Pullup Enable Register (PTDPUE)**

#### PTDPUE6–PTDPUE0 — Port D Input Pullup Enable Bits

These writeable bits are software programmable to enable pullup devices on an input port bit.

1 = Corresponding port D pin configured to have internal pullup

0 = Corresponding port D pin has internal pullup disconnected

## 16.6 Port E


Port E is a 2-bit special-function port that shares two of its pins with the serial communications interface (SCI) module.

### 16.6.1 Port E Data Register

The port E data register contains a data latch for each of the two port E pins.

Address: \$0008

	Bit 7	6	5	4	3	2	1	Bit 0
Read:	0	0	0	0	0	0	PTE1	PTE0
Write:								
Reset:	Unaffected by reset							
Alternative Function:							RxD	TxD

 = Unimplemented

**Figure 16-17. Port E Data Register (PTE)**

#### PTE1 and PTE0 — Port E Data Bits

PTE1 and PTE0 are read/write, software programmable bits. Data direction of each port E pin is under the control of the corresponding bit in data direction register E.

#### NOTE

*Data direction register E (DDRE) does not affect the data direction of port E pins that are being used by the SCI module. However, the DDRE bits always determine whether reading port E returns the states of the latches or the states of the pins. See [Table 16-6](#).*

**RxD — SCI Receive Data Input**

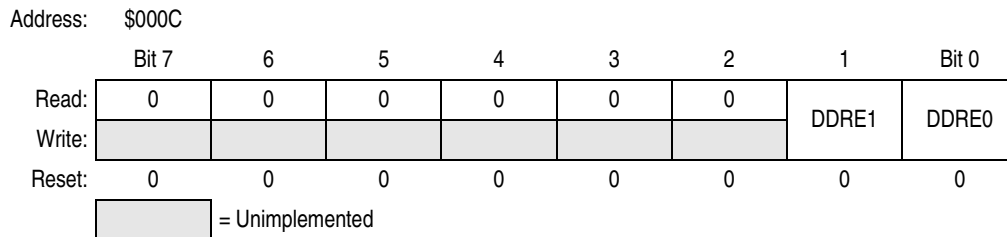
The PTE1/RxD pin is the receive data input for the SCI module. When the enable SCI bit, ENSCI, is clear, the SCI module is disabled, and the PTE1/RxD pin is available for general-purpose I/O. See [Chapter 18 Serial Communications Interface \(SCI\)](#).

**TxD — SCI Transmit Data Output**

The PTE0/TxD pin is the transmit data output for the SCI module. When the enable SCI bit, ENSCI, is clear, the SCI module is disabled, and the PTE0/TxD pin is available for general-purpose I/O. See [Chapter 18 Serial Communications Interface \(SCI\)](#).

**16.6.2 Data Direction Register E**

Data direction register E (DDRE) determines whether each port E pin is an input or an output. Writing a 1 to a DDRE bit enables the output buffer for the corresponding port E pin; a 0 disables the output buffer.



**Figure 16-18. Data Direction Register E (DDRE)**

**DDRE1 and DDRE0 — Data Direction Register E Bits**

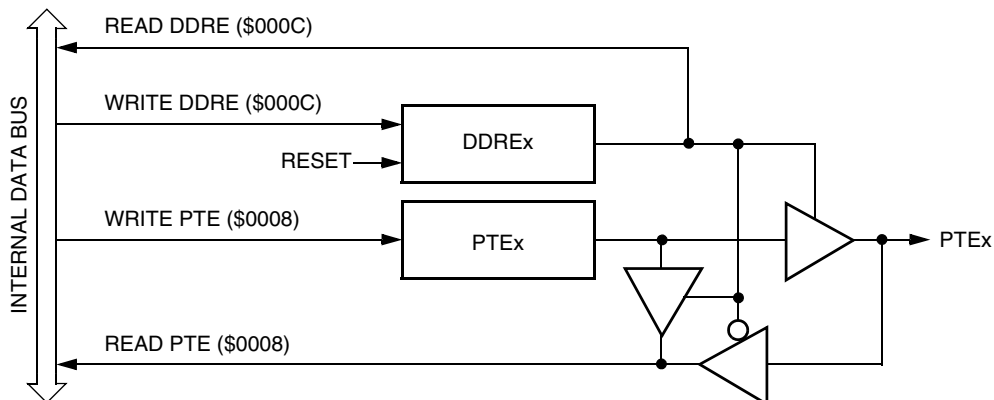
These read/write bits control port E data direction. Reset clears DDRE1 and DDRE0, configuring all port E pins as inputs.

- 1 = Corresponding port E pin configured as output
- 0 = Corresponding port E pin configured as input

**NOTE**

*Avoid glitches on port E pins by writing to the port E data register before changing data direction register E bits from 0 to 1.*

Figure 16-19 shows the port E I/O logic.



**Figure 16-19. Port E I/O Circuit**

When bit DDREx is a 1, reading address \$0008 reads the PTE<sub>x</sub> data latch. When bit DDREx is a 0, reading address \$0008 reads the voltage level on the pin. The data latch can always be written, regardless of the state of its data direction bit. [Table 16-6](#) summarizes the operation of the port E pins.

**Table 16-6. Port E Pin Functions**

DDRE Bit	PTE Bit	I/O Pin Mode	Accesses to DDRE	Accesses to PTE	
			Read/Write	Read	Write
0	X <sup>(1)</sup>	Input, Hi-Z <sup>(2)</sup>	DDRE1–DDRE0	Pin	PTE1–PTE0 <sup>(3)</sup>
1	X	Output	DDRE1–DDRE0]	PTE1–PTE0	PTE1–PTE0

Notes:

1. X = Don't care
2. Hi-Z = High impedance
3. Writing affects data register, but does not affect input.



# Chapter 17

## Random-Access Memory (RAM)

### 17.1 Introduction

This section describes the 384 bytes of RAM (random-access memory).

### 17.2 Functional Description

Addresses \$0040 through \$01BF are RAM locations. The location of the stack RAM is programmable. The 16-bit stack pointer allows the stack to be anywhere in the 64K byte memory space.

**NOTE**

*For correct operation, the stack pointer must point only to RAM locations.*

Within page zero are 192 bytes of RAM. Because the location of the stack RAM is programmable, all page zero RAM locations can be used for I/O control and user data or code. When the stack pointer is moved from its reset location at \$00FF out of page zero, direct addressing mode instructions can efficiently access all page zero RAM locations. Page zero RAM, therefore, provides ideal locations for frequently accessed global variables.

Before processing an interrupt, the CPU uses five bytes of the stack to save the contents of the CPU registers.

**NOTE**

*For M6805 compatibility, the H register is not stacked.*

During a subroutine call, the CPU uses two bytes of the stack to store the return address. The stack pointer decrements during pushes and increments during pulls.

**NOTE**

*Be careful when using nested subroutines. The CPU may overwrite data in the RAM during a subroutine or during the interrupt stacking operation.*





# Chapter 18

## Serial Communications Interface (SCI)

### 18.1 Introduction

This section describes the serial communications interface (SCI) module, which allows high-speed asynchronous communications with peripheral devices and other MCUs.

### 18.2 Features

Features of the SCI module include:

- Full-duplex operation
- Standard mark/space non-return-to-zero (NRZ) format
- 32 programmable baud rates
- Programmable 8-bit or 9-bit character length
- Separately enabled transmitter and receiver
- Separate receiver and transmitter CPU interrupt requests
- Programmable transmitter output polarity
- Two receiver wakeup methods:
  - Idle line wakeup
  - Address mark wakeup
- Interrupt-driven operation with eight interrupt flags:
  - Transmitter empty
  - Transmission complete
  - Receiver full
  - Idle receiver input
  - Receiver overrun
  - Noise error
  - Framing error
  - Parity error
- Receiver framing error detection
- Hardware parity checking
- 1/16 bit-time noise detection
- Configuration register bit, SCIBDSRC, to allow selection of baud rate clock source

## 18.3 Pin Name Conventions

The generic names of the SCI I/O pins are:

- RxD (receive data)
- TxD (transmit data)

SCI I/O (input/output) lines are implemented by sharing parallel I/O port pins. The full name of an SCI input or output reflects the name of the shared port pin. [Table 18-1](#) shows the full names and the generic names of the SCI I/O pins.

The generic pin names appear in the text of this chapter.

**Table 18-1. Pin Name Conventions**

<b>Generic Pin Names:</b>	RxD	TxD
<b>Full Pin Names:</b>	PE1/RxD	PE0/TxD

## 18.4 Functional Description

[Figure 18-1](#) shows the structure of the SCI module. The SCI allows full-duplex, asynchronous, NRZ serial communication among the MCU and remote devices, including other MCUs. The transmitter and receiver of the SCI operate independently, although they use the same baud rate generator. During normal operation, the CPU monitors the status of the SCI, writes the data to be transmitted, and processes received data.

The baud rate clock source for the SCI can be selected via the configuration bit, SCIBDSRC, of the CONFIG2 register (\$001E).

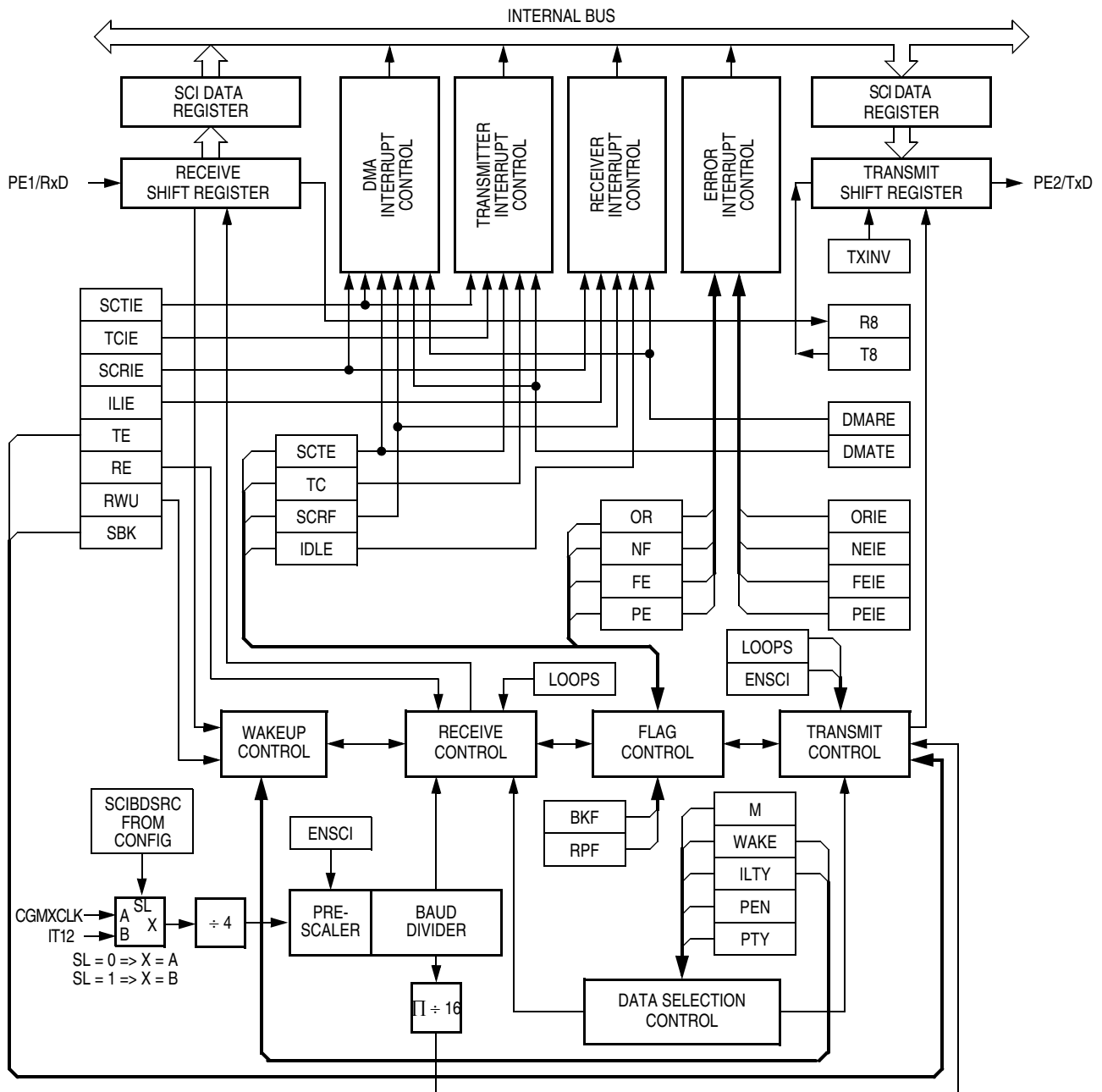


Figure 18-1. SCI Module Block Diagram

## Serial Communications Interface (SCI)

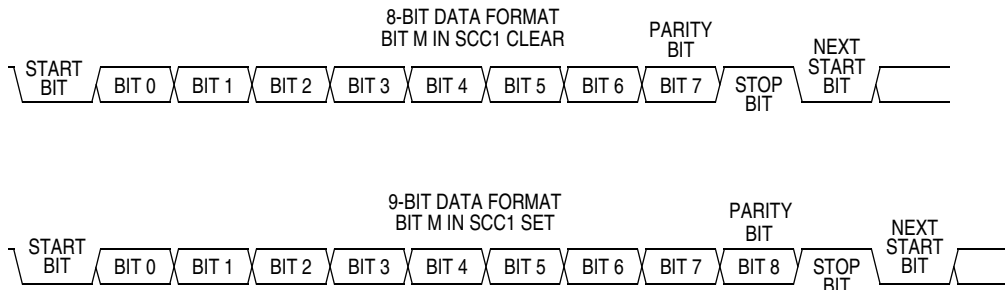
Addr.	Register Name	Bit 7	6	5	4	3	2	1	Bit 0	
\$0013	SCI Control Register 1 (SCC1)	Read:	LOOPS	ENSCI	TXINV	M	WAKE	ILTY	PEN	PTY
		Write:								
		Reset:	0	0	0	0	0	0	0	0
\$0014	SCI Control Register 2 (SCC2)	Read:	SCTIE	TCIE	SCRIE	ILIE	TE	RE	RWU	SBK
		Write:								
		Reset:	0	0	0	0	0	0	0	0
\$0015	SCI Control Register 3 (SCC3)	Read:	R8	T8	R	R	ORIE	NEIE	FEIE	PEIE
		Write:								
		Reset:	U	U	0	0	0	0	0	0
\$0016	SCI Status Register 1 (SCS1)	Read:	SCTE	TC	SCRf	IDLE	OR	NF	FE	PE
		Write:								
		Reset:	1	1	0	0	0	0	0	0
\$0017	SCI Status Register 2 (SCS2)	Read:	0	0	0	0	0	0	BKF	RPF
		Write:								
		Reset:	0	0	0	0	0	0	0	0
\$0018	SCI Data Register (SCDR)	Read:	R7	R6	R5	R4	R3	R2	R1	R0
		Write:	T7	T6	T5	T4	T3	T2	T1	T0
		Reset:	Unaffected by reset							
\$0019	SCI Baud Rate Register (SCBR)	Read:	0	0	SCP1	SCP0	R	SCR2	SCR1	SCR0
		Write:								
		Reset:	0	0	0	0	0	0	0	0

= Unimplemented      R = Reserved      U = Unaffected

**Figure 18-2. SCI I/O Register Summary**

### 18.4.1 Data Format

The SCI uses the standard non-return-to-zero mark/space data format illustrated in [Figure 18-3](#).



**Figure 18-3. SCI Data Formats**

### 18.4.2 Transmitter

Figure 18-4 shows the structure of the SCI transmitter.

The baud rate clock source for the SCI can be selected via the configuration bit, SCIBDSRC.

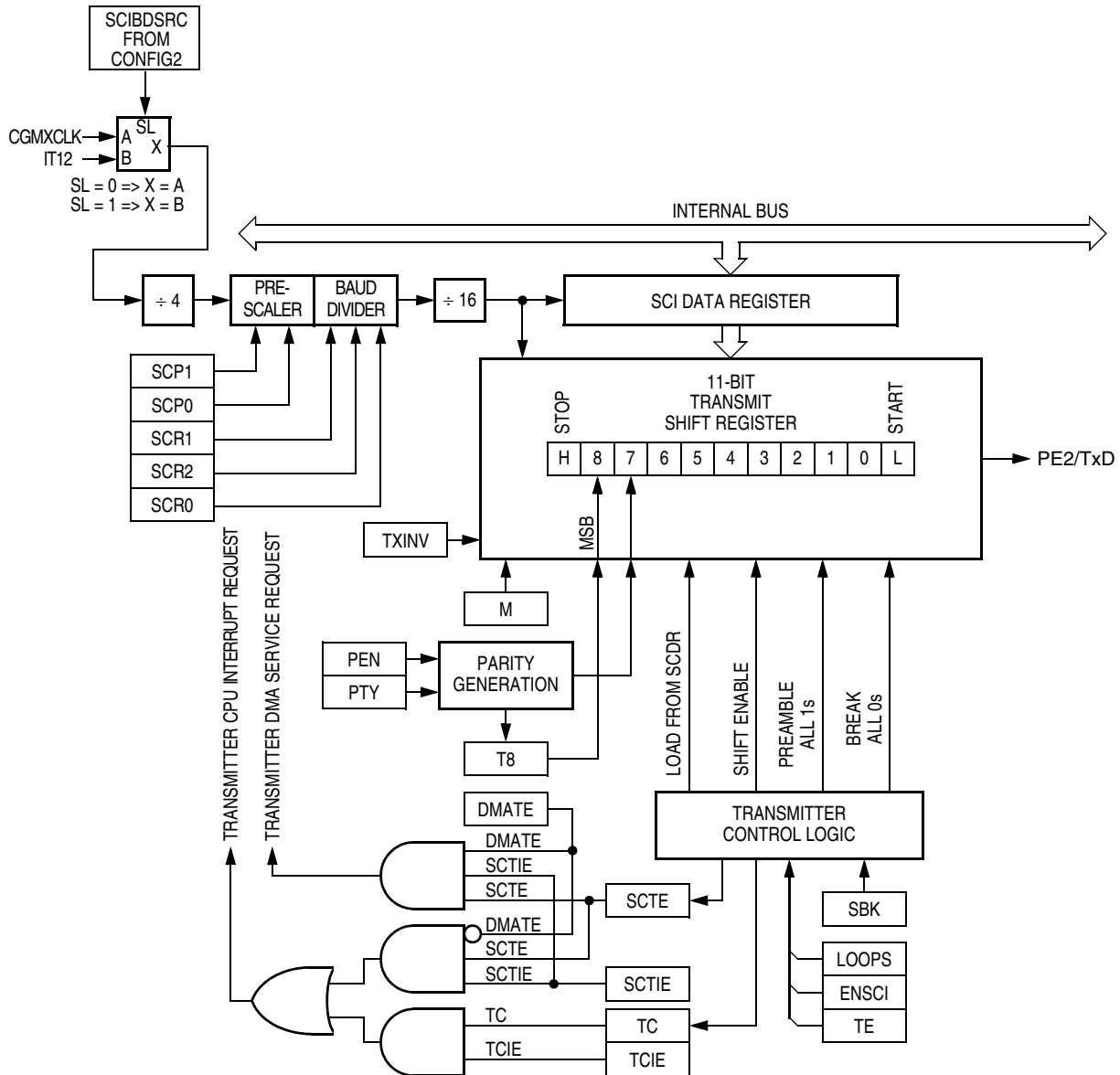


Figure 18-4. SCI Transmitter

### 18.4.2.1 Character Length

The transmitter can accommodate either 8-bit or 9-bit data. The state of the M bit in SCI control register 1 (SCC1) determines character length. When transmitting 9-bit data, bit T8 in SCI control register 3 (SCC3) is the ninth bit (bit 8).

### 18.4.2.2 Character Transmission

During an SCI transmission, the transmit shift register shifts a character out to the PE2/TxD pin. The SCI data register (SCDR) is the write-only buffer between the internal data bus and the transmit shift register. To initiate an SCI transmission:

1. Enable the SCI by writing a 1 to the enable SCI bit (ENSCI) in SCI control register 1 (SCC1).
2. Enable the transmitter by writing a 1 to the transmitter enable bit (TE) in SCI control register 2 (SCC2).
3. Clear the SCI transmitter empty bit by first reading SCI status register 1 (SCS1) and then writing to the SCDR. For 9-bit data, also write the T8 bit in SCC3.
4. Repeat step 3 for each subsequent transmission.

At the start of a transmission, transmitter control automatically loads the transmit shift register with a preamble of 1s. After the preamble shifts out, control logic transfers the SCDR data into the transmit shift register. A 0 start bit automatically goes into the least significant bit position of the transmit shift register. A 1 stop bit goes into the most significant bit position.

The SCI transmitter empty bit, SCTE, in SCS1 becomes set when the SCDR transfers a byte to the transmit shift register. The SCTE bit indicates that the SCDR can accept new data from the internal data bus. If the SCI transmit interrupt enable bit, SCTIE, in SCC2 is also set, the SCTE bit generates a transmitter CPU interrupt request.

When the transmit shift register is not transmitting a character, the PE2/TxD pin goes to the idle condition, high. If at any time software clears the ENSCI bit in SCI control register 1 (SCC1), the transmitter and receiver relinquish control of the port E pins.

### 18.4.2.3 Break Characters

Writing a 1 to the send break bit, SBK, in SCC2 loads the transmit shift register with a break character. A break character contains all 0s and has no start, stop, or parity bit. Break character length depends on the M bit in SCC1. As long as SBK is at 1, transmitter logic continuously loads break characters into the transmit shift register. After software clears the SBK bit, the shift register finishes transmitting the last break character and then transmits at least one 1. The automatic 1 at the end of a break character guarantees the recognition of the start bit of the next character.

The SCI recognizes a break character when a start bit is followed by eight or nine 0 data bits and a 0 where the stop bit should be.

Receiving a break character has these effects on SCI registers:

- Sets the framing error bit (FE) in SCS1
- Sets the SCI receiver full bit (SCRF) in SCS1
- Clears the SCI data register (SCDR)
- Clears the R8 bit in SCC3
- Sets the break flag bit (BKF) in SCS2
- May set the overrun (OR), noise flag (NF), parity error (PE), or reception in progress flag (RPF) bits

#### 18.4.2.4 Idle Characters

For TXINV = 0, (output not inverted) a transmitted idle character contains all logic 1s and has no start, stop, or parity bit. Idle character length depends on the M bit in SCC1. The preamble is a synchronizing idle character that begins every transmission.

If the TE bit is cleared during a transmission, the PE2/TxD pin becomes idle after completion of the transmission in progress. Clearing and then setting the TE bit during a transmission queues an idle character to be sent after the character currently being transmitted.

#### NOTE

*When a break sequence is followed immediately by an idle character, this SCI design exhibits a condition in which the break character length is reduced by one half bit time. In this instance, the break sequence will consist of a valid start bit, eight or nine data bits (as defined by the M bit in SCC1) of 0 and one half data bit length of 0 in the stop bit position followed immediately by the idle character. To ensure a break character of the proper length is transmitted, always queue up a byte of data to be transmitted while the final break sequence is in progress.*

*When queueing an idle character, return the TE bit to 1 before the stop bit of the current character shifts out to the TxD pin. Setting TE after the stop bit appears on TxD causes data previously written to the SCDR to be lost. A good time to toggle the TE bit for a queued idle character is when the SCTE bit becomes set and just before writing the next byte to the SCDR.*

#### 18.4.2.5 Inversion of Transmitted Output

The transmit inversion bit (TXINV) in SCI control register 1 (SCC1) reverses the polarity of transmitted data. All transmitted values, including idle, break, start, and stop bits, are inverted when TXINV is at logic 1. See [18.8.1 SCI Control Register 1](#).

#### 18.4.2.6 Transmitter Interrupts

These conditions can generate CPU interrupt requests from the SCI transmitter:

- SCI transmitter empty (SCTE) — The SCTE bit in SCS1 indicates that the SCDR has transferred a character to the transmit shift register. SCTE can generate a transmitter CPU interrupt request. Setting the SCI transmit interrupt enable bit, SCTIE, in SCC2 enables the SCTE bit to generate transmitter CPU interrupt requests.
- Transmission complete (TC) — The TC bit in SCS1 indicates that the transmit shift register and the SCDR are empty and that no break or idle character has been generated. The transmission complete interrupt enable bit, TCIE, in SCC2 enables the TC bit to generate transmitter CPU interrupt requests.

### 18.4.3 Receiver

[Figure 18-5](#) shows the structure of the SCI receiver.

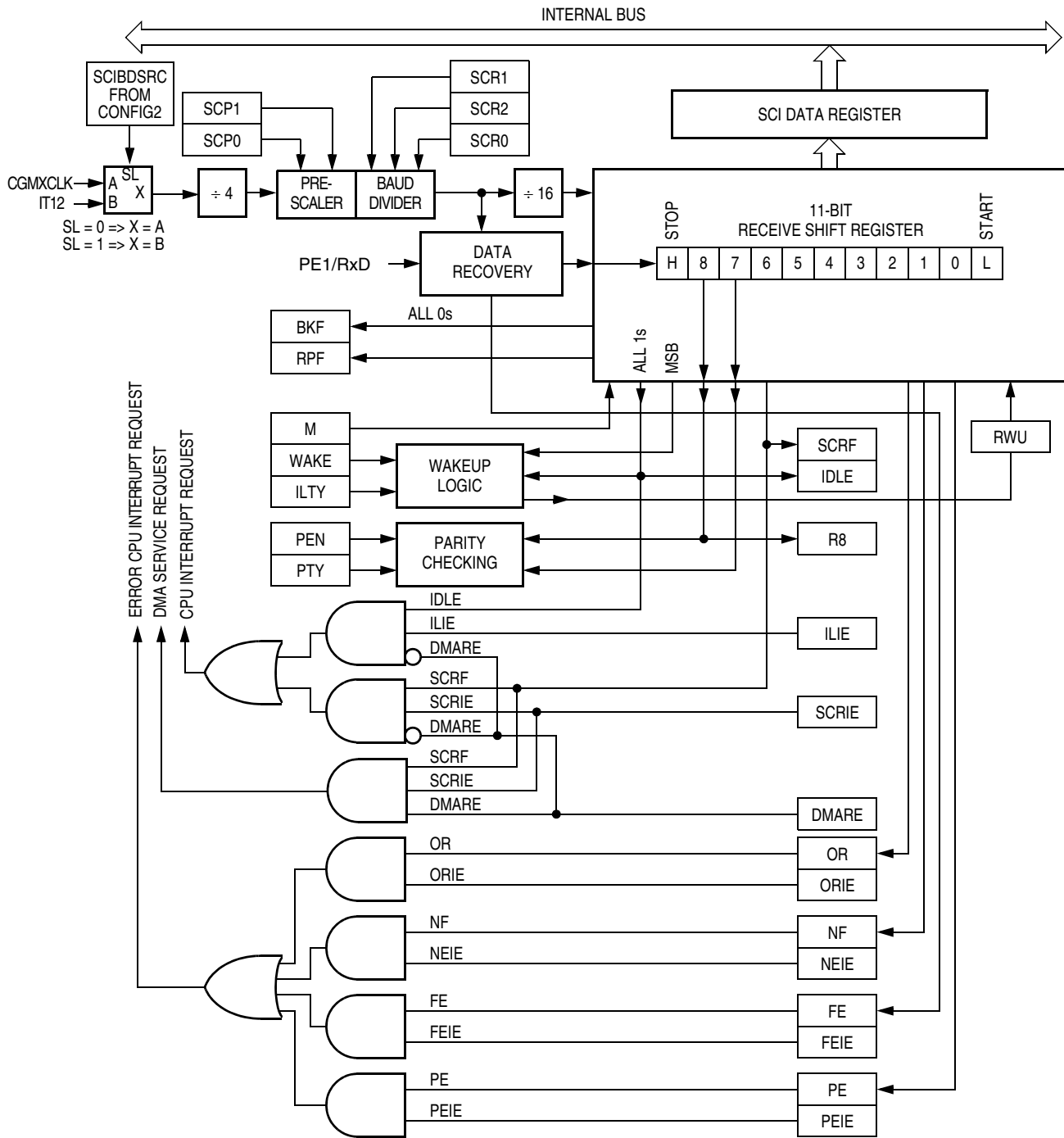


Figure 18-5. SCI Receiver Block Diagram

### 18.4.3.1 Character Length

The receiver can accommodate either 8-bit or 9-bit data. The state of the M bit in SCI control register 1 (SCC1) determines character length. When receiving 9-bit data, bit R8 in SCI control register 3 (SCC3) is the ninth bit (bit 8). When receiving 8-bit data, bit R8 is a copy of the eighth bit (bit 7).



### 18.4.3.2 Character Reception

During an SCI reception, the receive shift register shifts characters in from the PE1/RxD pin. The SCI data register (SCDR) is the read-only buffer between the internal data bus and the receive shift register.

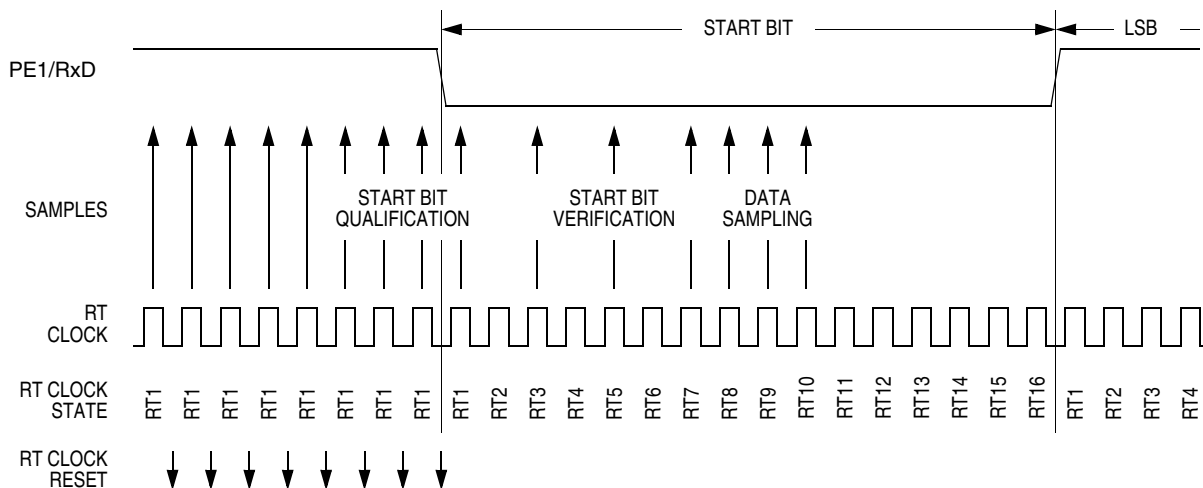
After a complete character shifts into the receive shift register, the data portion of the character transfers to the SCDR. The SCI receiver full bit, SCRF, in SCI status register 1 (SCS1) becomes set, indicating that the received byte can be read. If the SCI receive interrupt enable bit, SCRIE, in SCC2 is also set, the SCRF bit generates a receiver CPU interrupt request.

### 18.4.3.3 Data Sampling

The receiver samples the PE1/RxD pin at the RT clock rate. The RT clock is an internal signal with a frequency 16 times the baud rate. To adjust for baud rate mismatch, the RT clock is resynchronized at the following times (see [Figure 18-6](#)):

- After every start bit
- After the receiver detects a data bit change from 1 to 0 (after the majority of data bit samples at RT8, RT9, and RT10 returns a valid 1 and the majority of the next RT8, RT9, and RT10 samples returns a valid 0)

To locate the start bit, data recovery does an asynchronous search for a 0 preceded by three 1s. When the falling edge of a possible start bit occurs, the RT clock begins to count to 16.



**Figure 18-6. Receiver Data Sampling**

To verify the start bit and to detect noise, data recovery logic takes samples at RT3, RT5, and RT7. [Table 18-2](#) summarizes the results of the start bit verification samples.

**Table 18-2. Start Bit Verification**

RT3, RT5, and RT7 Samples	Start Bit Verification	Noise Flag
000	Yes	0
001	Yes	1
010	Yes	1
011	No	0
100	Yes	1

**Table 18-2. Start Bit Verification (Continued)**

RT3, RT5, and RT7 Samples	Start Bit Verification	Noise Flag
101	No	0
110	No	0
111	No	0

If start bit verification is not successful, the RT clock is reset and a new search for a start bit begins.

To determine the value of a data bit and to detect noise, recovery logic takes samples at RT8, RT9, and RT10. [Table 18-3](#) summarizes the results of the data bit samples.

**Table 18-3. Data Bit Recovery**

RT8, RT9, and RT10 Samples	Data Bit Determination	Noise Flag
000	0	0
001	0	1
010	0	1
011	1	1
100	0	1
101	1	1
110	1	1
111	1	0

**NOTE**

*The RT8, RT9, and RT10 samples do not affect start bit verification. If any or all of the RT8, RT9, and RT10 start bit samples are 1s following a successful start bit verification, the noise flag (NF) is set and the receiver assumes that the bit is a start bit.*

To verify a stop bit and to detect noise, recovery logic takes samples at RT8, RT9, and RT10. [Table 18-4](#) summarizes the results of the stop bit samples.

**Table 18-4. Stop Bit Recovery**

RT8, RT9, and RT10 Samples	Framing Error Flag	Noise Flag
000	1	0
001	1	1
010	1	1
011	0	1
100	1	1
101	0	1
110	0	1
111	0	0

**18.4.3.4 Framing Errors**

If the data recovery logic does not detect a 1 where the stop bit should be in an incoming character, it sets the framing error bit, FE, in SCS1. A break character also sets the FE bit because a break character has no stop bit. The FE bit is set at the same time that the SCRF bit is set.

### 18.4.3.5 Baud Rate Tolerance

A transmitting device may be operating at a baud rate below or above the receiver baud rate. Accumulated bit time misalignment can cause one of the three stop bit data samples to fall outside the actual stop bit. Then a noise error occurs. If more than one of the samples is outside the stop bit, a framing error occurs. In most applications, the baud rate tolerance is much more than the degree of misalignment that is likely to occur.

As the receiver samples an incoming character, it resynchronizes the RT clock on any valid falling edge within the character. Resynchronization within characters corrects misalignments between transmitter bit times and receiver bit times.

### 18.4.3.6 Slow Data Tolerance

Figure 18-7 shows how much a slow received character can be misaligned without causing a noise error or a framing error. The slow stop bit begins at RT8 instead of RT1 but arrives in time for the stop bit data samples at RT8, RT9, and RT10.

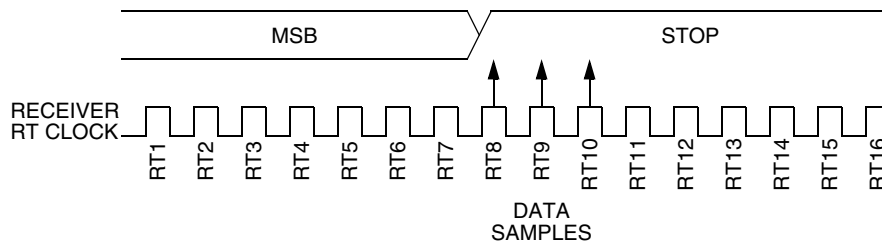


Figure 18-7. Slow Data

For an 8-bit character, data sampling of the stop bit takes the receiver  $9 \text{ bit times} \times 16 \text{ RT cycles} + 10 \text{ RT cycles} = 154 \text{ RT cycles}$ .

With the misaligned character shown in Figure 18-7, the receiver counts 154 RT cycles at the point when the count of the transmitting device is  $9 \text{ bit times} \times 16 \text{ RT cycles} + 3 \text{ RT cycles} = 147 \text{ RT cycles}$ .

The maximum percent difference between the receiver count and the transmitter count of a slow 8-bit character with no errors is

$$\left| \frac{154 - 147}{154} \right| \times 100 = 4.54\%$$

For a 9-bit character, data sampling of the stop bit takes the receiver  $10 \text{ bit times} \times 16 \text{ RT cycles} + 10 \text{ RT cycles} = 170 \text{ RT cycles}$ .

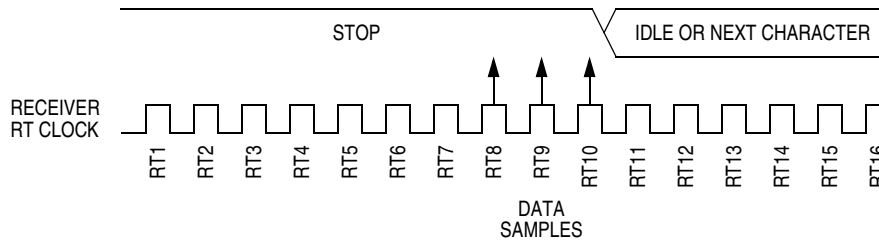
With the misaligned character shown in Figure 18-7, the receiver counts 170 RT cycles at the point when the count of the transmitting device is  $10 \text{ bit times} \times 16 \text{ RT cycles} + 3 \text{ RT cycles} = 163 \text{ RT cycles}$ .

The maximum percent difference between the receiver count and the transmitter count of a slow 9-bit character with no errors is

$$\left| \frac{170 - 163}{170} \right| \times 100 = 4.12\%$$

### 18.4.3.7 Fast Data Tolerance

Figure 18-8 shows how much a fast received character can be misaligned without causing a noise error or a framing error. The fast stop bit ends at RT10 instead of RT16 but is still there for the stop bit data samples at RT8, RT9, and RT10.



**Figure 18-8. Fast Data**

For an 8-bit character, data sampling of the stop bit takes the receiver  $9 \text{ bit times} \times 16 \text{ RT cycles} + 10 \text{ RT cycles} = 154 \text{ RT cycles}$ .

With the misaligned character shown in Figure 18-8, the receiver counts 154 RT cycles at the point when the count of the transmitting device is  $10 \text{ bit times} \times 16 \text{ RT cycles} = 160 \text{ RT cycles}$ .

The maximum percent difference between the receiver count and the transmitter count of a fast 8-bit character with no errors is

$$\left| \frac{154 - 160}{154} \right| \times 100 = 3.90\%$$

For a 9-bit character, data sampling of the stop bit takes the receiver  $10 \text{ bit times} \times 16 \text{ RT cycles} + 10 \text{ RT cycles} = 170 \text{ RT cycles}$ .

With the misaligned character shown in Figure 18-8, the receiver counts 170 RT cycles at the point when the count of the transmitting device is  $11 \text{ bit times} \times 16 \text{ RT cycles} = 176 \text{ RT cycles}$ .

The maximum percent difference between the receiver count and the transmitter count of a fast 9-bit character with no errors is

$$\left| \frac{170 - 176}{170} \right| \times 100 = 3.53\%$$

### 18.4.3.8 Receiver Wakeup

So that the MCU can ignore transmissions intended only for other receivers in multiple-receiver systems, the receiver can be put into a standby state. Setting the receiver wakeup bit, RWU, in SCC2 puts the receiver into a standby state during which receiver interrupts are disabled.

Depending on the state of the WAKE bit in SCC1, either of two conditions on the PE1/RxD pin can bring the receiver out of the standby state:

- **Address mark** — An address mark is a logic 1 in the most significant bit position of a received character. When the WAKE bit is set, an address mark wakes the receiver from the standby state by clearing the RWU bit. The address mark also sets the SCI receiver full bit, SCRF. Software can then compare the character containing the address mark to the user-defined address of the

receiver. If they are the same, the receiver remains awake and processes the characters that follow. If they are not the same, software can set the RWU bit and put the receiver back into the standby state.

- Idle input line condition — When the WAKE bit is clear, an idle character on the PE1/RxD pin wakes the receiver from the standby state by clearing the RWU bit. The idle character that wakes the receiver does not set the receiver idle bit, IDLE, or the SCI receiver full bit, SCRF. The idle line type bit, ILTY, determines whether the receiver begins counting logic 1s as idle character bits after the start bit or after the stop bit.

**NOTE**

*With the WAKE bit clear, setting the RWU bit after the RxD pin has been idle may cause the receiver to wake up immediately.*

#### 18.4.3.9 Receiver Interrupts

The following sources can generate CPU interrupt requests from the SCI receiver:

- SCI receiver full (SCRF) — The SCRF bit in SCS1 indicates that the receive shift register has transferred a character to the SCDR. SCRF can generate a receiver CPU interrupt request. Setting the SCI receive interrupt enable bit, SCRIE, in SCC2 enables the SCRF bit to generate receiver CPU interrupts.
- Idle input (IDLE) — The IDLE bit in SCS1 indicates that 10 or 11 consecutive 1s shifted in from the PE1/RxD pin. The idle line interrupt enable bit, ILIE, in SCC2 enables the IDLE bit to generate CPU interrupt requests.

#### 18.4.3.10 Error Interrupts

The following receiver error flags in SCS1 can generate CPU interrupt requests:

- Receiver overrun (OR) — The OR bit indicates that the receive shift register shifted in a new character before the previous character was read from the SCDR. The previous character remains in the SCDR, and the new character is lost. The overrun interrupt enable bit, ORIE, in SCC3 enables OR to generate SCI error CPU interrupt requests.
- Noise flag (NF) — The NF bit is set when the SCI detects noise on incoming data or break characters, including start, data, and stop bits. The noise error interrupt enable bit, NEIE, in SCC3 enables NF to generate SCI error CPU interrupt requests.
- Framing error (FE) — The FE bit in SCS1 is set when a 0 occurs where the receiver expects a stop bit. The framing error interrupt enable bit, FEIE, in SCC3 enables FE to generate SCI error CPU interrupt requests.
- Parity error (PE) — The PE bit in SCS1 is set when the SCI detects a parity error in incoming data. The parity error interrupt enable bit, PEIE, in SCC3 enables PE to generate SCI error CPU interrupt requests.

## 18.5 Low-Power Modes

The WAIT and STOP instructions put the MCU in low power-consumption standby modes.

### 18.5.1 Wait Mode

The SCI module remains active after the execution of a WAIT instruction. Any enabled CPU interrupt request from the SCI module can bring the MCU out of wait mode.

If SCI module functions are not required during wait mode, reduce power consumption by disabling the module before executing the WAIT instruction.

Refer to [Chapter 3 Low-Power Modes](#) for information on exiting wait mode.

### 18.5.2 Stop Mode

The SCI module is inactive in stop mode. The STOP instruction does not affect SCI register states. SCI module operation resumes when the MCU exits stop mode.

Because the internal clock is inactive during stop mode, entering stop mode during an SCI transmission or reception results in invalid data.

Refer to [Chapter 3 Low-Power Modes](#) for information on exiting stop mode.

## 18.6 SCI During Break Module Interrupts

The system integration module (SIM) controls whether status bits in other modules can be cleared during the break state. The BCFE bit in the SIM break flag control register (SBFCR) enables software to clear status bits during the break state.

To allow software to clear status bits during a break interrupt, write a 1 to the BCFE bit. If a status bit is cleared during the break state, it remains cleared when the MCU exits the break state.

To protect status bits during the break state, write a 0 to the BCFE bit. With BCFE at 0 (its default state), software can read and write I/O registers during the break state without affecting status bits. Some status bits have a 2-step read/write clearing procedure. If software does the first step on such a bit before the break, the bit cannot change during the break state as long as BCFE is at 0. After the break, doing the second step clears the status bit.

## 18.7 I/O Signals

Port E shares two of its pins with the SCI module. The two SCI I/O pins are:

- PE2/TxD — Transmit data
- PE1/RxD — Receive data

### 18.7.1 PE2/TxD (Transmit Data)

The PE2/TxD pin is the serial data output from the SCI transmitter. The SCI shares the PE2/TxD pin with port E. When the SCI is enabled, the PE2/TxD pin is an output regardless of the state of the DDRE0 bit in data direction register E (DDRE).

## 18.7.2 PE1/RxD (Receive Data)

The PE1/RxD pin is the serial data input to the SCI receiver. The SCI shares the PE1/RxD pin with port E. When the SCI is enabled, the PE1/RxD pin is an input regardless of the state of the DDRE1 bit in data direction register E (DDRE).

## 18.8 I/O Registers

These I/O registers control and monitor SCI operation:

- SCI control register 1 (SCC1)
- SCI control register 2 (SCC2)
- SCI control register 3 (SCC3)
- SCI status register 1 (SCS1)
- SCI status register 2 (SCS2)
- SCI data register (SCDR)
- SCI baud rate register (SCBR)

### 18.8.1 SCI Control Register 1

SCI control register 1:

- Enables loop mode operation
- Enables the SCI
- Controls output polarity
- Controls character length
- Controls SCI wakeup method
- Controls idle character detection
- Enables parity function
- Controls parity type

Address:	\$0013							
	Bit 7	6	5	4	3	2	1	Bit 0
Read:	LOOPS	ENSCI	TXINV	M	WAKE	ILTY	PEN	PTY
Write:								
Reset:	0	0	0	0	0	0	0	0

**Figure 18-9. SCI Control Register 1 (SCC1)**

#### LOOPS — Loop Mode Select Bit

This read/write bit enables loop mode operation. In loop mode the PE1/RxD pin is disconnected from the SCI, and the transmitter output goes into the receiver input. Both the transmitter and the receiver must be enabled to use loop mode. Reset clears the LOOPS bit.

1 = Loop mode enabled

0 = Normal operation enabled

**ENSCI — Enable SCI Bit**

This read/write bit enables the SCI and the SCI baud rate generator. Clearing ENSCI sets the SCTE and TC bits in SCI status register 1 and disables transmitter interrupts. Reset clears the ENSCI bit.

- 1 = SCI enabled
- 0 = SCI disabled

**TXINV — Transmit Inversion Bit**

This read/write bit reverses the polarity of transmitted data. Reset clears the TXINV bit.

- 1 = Transmitter output inverted
- 0 = Transmitter output not inverted

**NOTE**

*Setting the TXINV bit inverts all transmitted values, including idle, break, start, and stop bits.*

**M — Mode (Character Length) Bit**

This read/write bit determines whether SCI characters are eight or nine bits long. See [Table 18-5](#). The ninth bit can serve as an extra stop bit, as a receiver wakeup signal, or as a parity bit. Reset clears the M bit.

- 1 = 9-bit SCI characters
- 0 = 8-bit SCI characters

**WAKE — Wakeup Condition Bit**

This read/write bit determines which condition wakes up the SCI: a 1 (address mark) in the most significant bit position of a received character or an idle condition on the PE1/RxD pin. Reset clears the WAKE bit.

- 1 = Address mark wakeup
- 0 = Idle line wakeup

**ILTY — Idle Line Type Bit**

This read/write bit determines when the SCI starts counting 1s as idle character bits. The counting begins either after the start bit or after the stop bit. If the count begins after the start bit, then a string of 1s preceding the stop bit may cause false recognition of an idle character. Beginning the count after the stop bit avoids false idle character recognition, but requires properly synchronized transmissions. Reset clears the ILTY bit.

- 1 = Idle character bit count begins after stop bit
- 0 = Idle character bit count begins after start bit

**PEN — Parity Enable Bit**

This read/write bit enables the SCI parity function. See [Table 18-5](#). When enabled, the parity function inserts a parity bit in the most significant bit position. See [Figure 18-3](#). Reset clears the PEN bit.

- 1 = Parity function enabled
- 0 = Parity function disabled

**PTY — Parity Bit**

This read/write bit determines whether the SCI generates and checks for odd parity or even parity. See [Table 18-5](#). Reset clears the PTY bit.

- 1 = Odd parity
- 0 = Even parity

**NOTE**

*Changing the PTY bit in the middle of a transmission or reception can generate a parity error.*



Table 18-5. Character Format Selection

Control Bits		Character Format				
M	PEN and PTY	Start Bits	Data Bits	Parity	Stop Bits	Character Length
0	0X	1	8	None	1	10 bits
1	0X	1	9	None	1	11 bits
0	10	1	7	Even	1	10 bits
0	11	1	7	Odd	1	10 bits
1	10	1	8	Even	1	11 bits
1	11	1	8	Odd	1	11 bits

### 18.8.2 SCI Control Register 2

SCI control register 2:

- Enables the following CPU interrupt requests:
  - Enables the SCTE bit to generate transmitter CPU interrupt requests
  - Enables the TC bit to generate transmitter CPU interrupt requests
  - Enables the SCRF bit to generate receiver CPU interrupt requests
  - Enables the IDLE bit to generate receiver CPU interrupt requests
- Enables the transmitter
- Enables the receiver
- Enables SCI wakeup
- Transmits SCI break characters

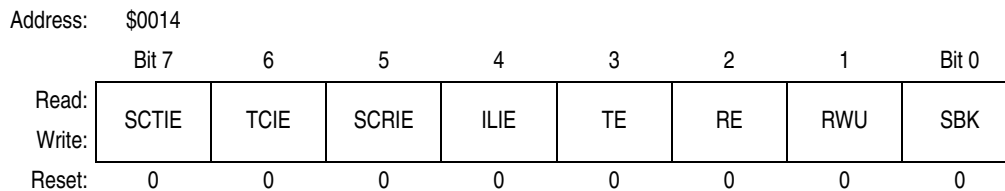


Figure 18-10. SCI Control Register 2 (SCC2)

#### SCTIE — SCI Transmit Interrupt Enable Bit

This read/write bit enables the SCTE bit to generate SCI transmitter CPU interrupt requests. Reset clears the SCTIE bit.

- 1 = SCTE enabled to generate CPU interrupt
- 0 = SCTE not enabled to generate CPU interrupt

#### TCIE — Transmission Complete Interrupt Enable Bit

This read/write bit enables the TC bit to generate SCI transmitter CPU interrupt requests. Reset clears the TCIE bit.

- 1 = TC enabled to generate CPU interrupt requests
- 0 = TC not enabled to generate CPU interrupt requests

#### SCRIE — SCI Receive Interrupt Enable Bit

This read/write bit enables the SCRF bit to generate SCI receiver CPU interrupt requests. Reset clears the SCRIE bit.

- 1 = SCRF enabled to generate CPU interrupt
- 0 = SCRF not enabled to generate CPU interrupt

**ILIE — Idle Line Interrupt Enable Bit**

This read/write bit enables the IDLE bit to generate SCI receiver CPU interrupt requests. Reset clears the ILIE bit.

- 1 = IDLE enabled to generate CPU interrupt requests
- 0 = IDLE not enabled to generate CPU interrupt requests

**TE — Transmitter Enable Bit**

Setting this read/write bit begins the transmission by sending a preamble of 10 or 11 1s from the transmit shift register to the PE2/TxD pin. If software clears the TE bit, the transmitter completes any transmission in progress before the PE2/TxD returns to the idle condition (1). Clearing and then setting TE during a transmission queues an idle character to be sent after the character currently being transmitted. Reset clears the TE bit.

- 1 = Transmitter enabled
- 0 = Transmitter disabled

**NOTE**

*Writing to the TE bit is not allowed when the enable SCI bit (ENSCI) is clear. ENSCI is in SCI control register 1.*

**RE — Receiver Enable Bit**

Setting this read/write bit enables the receiver. Clearing the RE bit disables the receiver but does not affect receiver interrupt flag bits. Reset clears the RE bit.

- 1 = Receiver enabled
- 0 = Receiver disabled

**NOTE**

*Writing to the RE bit is not allowed when the enable SCI bit (ENSCI) is clear. ENSCI is in SCI control register 1.*

**RWU — Receiver Wakeup Bit**

This read/write bit puts the receiver in a standby state during which receiver interrupts are disabled. The WAKE bit in SCC1 determines whether an idle input or an address mark brings the receiver out of the standby state and clears the RWU bit. Reset clears the RWU bit.

- 1 = Standby state
- 0 = Normal operation

**SBK — Send Break Bit**

Setting and then clearing this read/write bit transmits a break character followed by a 1. The 1 after the break character guarantees recognition of a valid start bit. If SBK remains set, the transmitter continuously transmits break characters with no 1s between them. Reset clears the SBK bit.

- 1 = Transmit break characters
- 0 = No break characters being transmitted

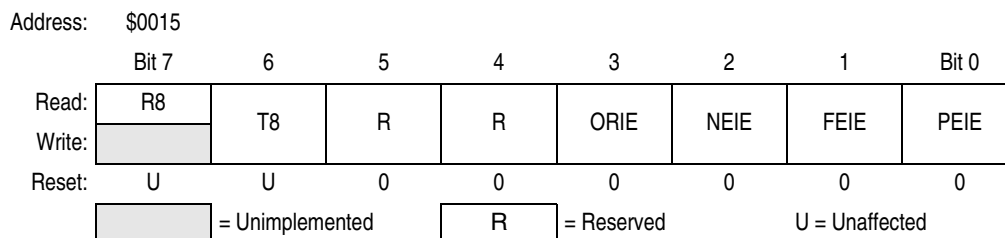
**NOTE**

*Do not toggle the SBK bit immediately after setting the SCTE bit. Toggling SBK before the preamble begins causes the SCI to send a break character instead of a preamble.*

### 18.8.3 SCI Control Register 3

SCI control register 3:

- Stores the ninth SCI data bit received and the ninth SCI data bit to be transmitted
- Enables these interrupts:
  - Receiver overrun interrupts
  - Noise error interrupts
  - Framing error interrupts
- Parity error interrupts



**Figure 18-11. SCI Control Register 3 (SCC3)**

#### R8 — Received Bit 8

When the SCI is receiving 9-bit characters, R8 is the read-only ninth bit (bit 8) of the received character. R8 is received at the same time that the SCDR receives the other 8 bits.

When the SCI is receiving 8-bit characters, R8 is a copy of the eighth bit (bit 7). Reset has no effect on the R8 bit.

#### T8 — Transmitted Bit 8

When the SCI is transmitting 9-bit characters, T8 is the read/write ninth bit (bit 8) of the transmitted character. T8 is loaded into the transmit shift register at the same time that the SCDR is loaded into the transmit shift register. Reset clears the T8 bit.

#### ORIE — Receiver Overrun Interrupt Enable Bit

This read/write bit enables SCI error CPU interrupt requests generated by the receiver overrun bit, OR.

- 1 = SCI error CPU interrupt requests from OR bit enabled
- 0 = SCI error CPU interrupt requests from OR bit disabled

#### NEIE — Receiver Noise Error Interrupt Enable Bit

This read/write bit enables SCI error CPU interrupt requests generated by the noise error bit, NE. Reset clears NEIE.

- 1 = SCI error CPU interrupt requests from NE bit enabled
- 0 = SCI error CPU interrupt requests from NE bit disabled

#### FEIE — Receiver Framing Error Interrupt Enable Bit

This read/write bit enables SCI error CPU interrupt requests generated by the framing error bit, FE. Reset clears FEIE.

- 1 = SCI error CPU interrupt requests from FE bit enabled
- 0 = SCI error CPU interrupt requests from FE bit disabled

#### PEIE — Receiver Parity Error Interrupt Enable Bit

This read/write bit enables SCI error CPU interrupt requests generated by the parity error bit, PE. See [18.8.4 SCI Status Register 1](#). Reset clears PEIE.

- 1 = SCI error CPU interrupt requests from PE bit enabled
- 0 = SCI error CPU interrupt requests from PE bit disabled

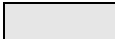
### 18.8.4 SCI Status Register 1

SCI status register 1 (SCS1) contains flags to signal these conditions:

- Transfer of SCDR data to transmit shift register complete
- Transmission complete
- Transfer of receive shift register data to SCDR complete
- Receiver input idle
- Receiver overrun
- Noisy data
- Framing error
- Parity error

Address: \$0016

	Bit 7	6	5	4	3	2	1	Bit 0
Read:	SCTE	TC	SCRF	IDLE	OR	NF	FE	PE
Write:								
Reset:	1	1	0	0	0	0	0	0

 = Unimplemented

**Figure 18-12. SCI Status Register 1 (SCS1)**

#### SCTE — SCI Transmitter Empty Bit

This clearable, read-only bit is set when the SCDR transfers a character to the transmit shift register. SCTE can generate an SCI transmitter CPU interrupt request. When the SCTIE bit in SCC2 is set, SCTE generates an SCI transmitter CPU interrupt request. In normal operation, clear the SCTE bit by reading SCS1 with SCTE set and then writing to SCDR. Reset sets the SCTE bit.

- 1 = SCDR data transferred to transmit shift register
- 0 = SCDR data not transferred to transmit shift register

#### TC — Transmission Complete Bit

This read-only bit is set when the SCTE bit is set, and no data, preamble, or break character is being transmitted. TC generates an SCI transmitter CPU interrupt request if the TCIE bit in SCC2 is also set. TC is automatically cleared when data, preamble or break is queued and ready to be sent. There may be up to 1.5 transmitter clocks of latency between queuing data, preamble, and break and the transmission actually starting. Reset sets the TC bit.

- 1 = No transmission in progress
- 0 = Transmission in progress

#### SCRF — SCI Receiver Full Bit

This clearable, read-only bit is set when the data in the receive shift register transfers to the SCI data register. SCRF can generate an SCI receiver CPU interrupt request. When the SCRIE bit in SCC2 is set, SCRF generates a CPU interrupt request. In normal operation, clear the SCRF bit by reading SCS1 with SCRF set and then reading the SCDR. Reset clears SCRF.

- 1 = Received data available in SCDR
- 0 = Data not available in SCDR

**IDLE — Receiver Idle Bit**

This clearable, read-only bit is set when 10 or 11 consecutive logic 1s appear on the receiver input. IDLE generates an SCI receiver CPU interrupt request if the ILIE bit in SCC2 is also set. Clear the IDLE bit by reading SCS1 with IDLE set and then reading the SCDR. After the receiver is enabled, it must receive a valid character that sets the SCRF bit before an idle condition can set the IDLE bit. Also, after the IDLE bit has been cleared, a valid character must again set the SCRF bit before an idle condition can set the IDLE bit. Reset clears the IDLE bit.

1 = Receiver input idle

0 = Receiver input active (or idle since the IDLE bit was cleared)

**OR — Receiver Overrun Bit**

This clearable, read-only bit is set when software fails to read the SCDR before the receive shift register receives the next character. The OR bit generates an SCI error CPU interrupt request if the ORIE bit in SCC3 is also set. The data in the shift register is lost, but the data already in the SCDR is not affected. Clear the OR bit by reading SCS1 with OR set and then reading the SCDR. Reset clears the OR bit.

1 = Receive shift register full and SCRF = 1

0 = No receiver overrun

Software latency may allow an overrun to occur between reads of SCS1 and SCDR in the flag-clearing sequence. [Figure 18-13](#) shows the normal flag-clearing sequence and an example of an overrun caused by a delayed flag-clearing sequence. The delayed read of SCDR does not clear the OR bit because OR was not set when SCS1 was read. Byte 2 caused the overrun and is lost. The next flag-clearing sequence reads byte 3 in the SCDR instead of byte 2.

In applications that are subject to software latency or in which it is important to know which byte is lost due to an overrun, the flag-clearing routine can check the OR bit in a second read of SCS1 after reading the data register.

**NF — Receiver Noise Flag Bit**

This clearable, read-only bit is set when the SCI detects noise on the PE1/RxD pin. NF generates an NF CPU interrupt request if the NEIE bit in SCC3 is also set. Clear the NF bit by reading SCS1 and then reading the SCDR. Reset clears the NF bit.

1 = Noise detected

0 = No noise detected

**FE — Receiver Framing Error Bit**

This clearable, read-only bit is set when a logic 0 is accepted as the stop bit. FE generates an SCI error CPU interrupt request if the FEIE bit in SCC3 also is set. Clear the FE bit by reading SCS1 with FE set and then reading the SCDR. Reset clears the FE bit.

1 = Framing error detected

0 = No framing error detected

**PE — Receiver Parity Error Bit**

This clearable, read-only bit is set when the SCI detects a parity error in incoming data. PE generates a PE CPU interrupt request if the PEIE bit in SCC3 is also set. Clear the PE bit by reading SCS1 with PE set and then reading the SCDR. Reset clears the PE bit.

1 = Parity error detected

0 = No parity error detected

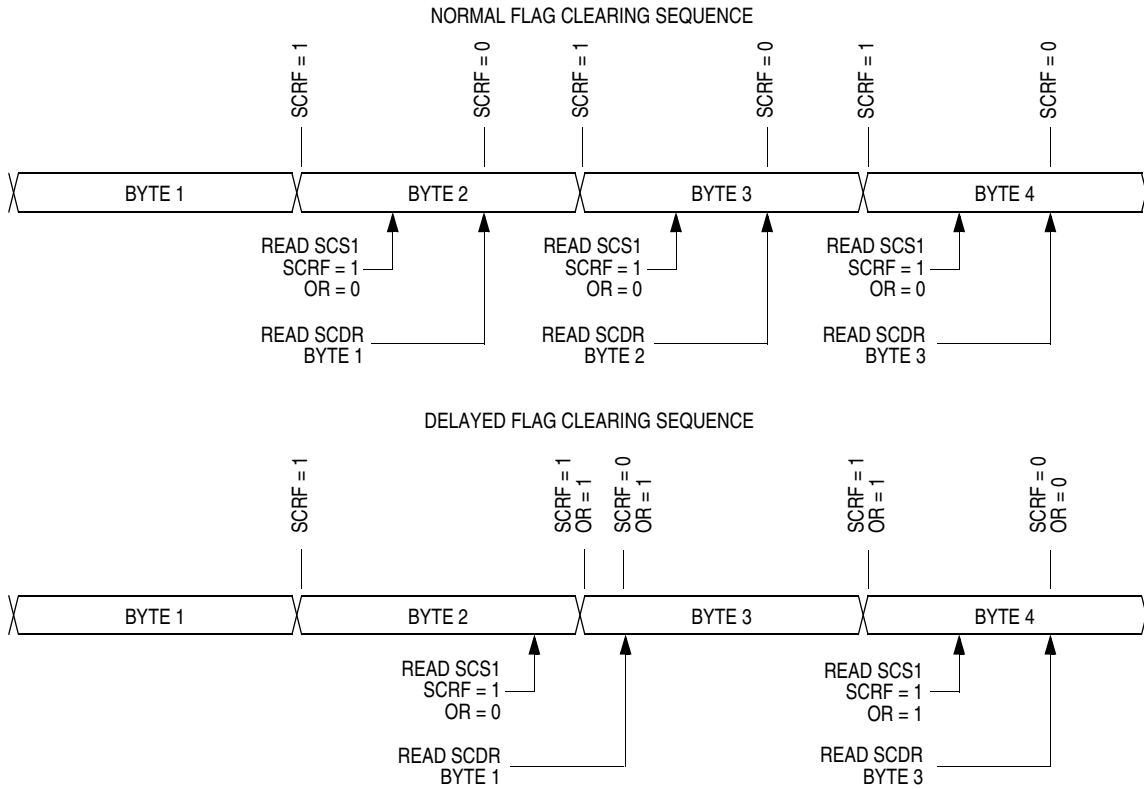


Figure 18-13. Flag Clearing Sequence

### 18.8.5 SCI Status Register 2

SCI status register 2 contains flags to signal the following conditions:

- Break character detected
- Incoming data

Address: \$0017

	Bit 7	6	5	4	3	2	1	Bit 0
Read:	0	0	0	0	0	0	BKF	RPF
Write:								
Reset:	0	0	0	0	0	0	0	0

= Unimplemented

Figure 18-14. SCI Status Register 2 (SCS2)

#### BKF — Break Flag Bit

This clearable, read-only bit is set when the SCI detects a break character on the PE1/RxD pin. In SCS1, the FE and SCRF bits are also set. In 9-bit character transmissions, the R8 bit in SCC3 is cleared. BKF does not generate a CPU interrupt request. Clear BKF by reading SCS2 with BKF set and then reading the SCDR. Once cleared, BKF can become set again only after 1s again appear on the PE1/RxD pin followed by another break character. Reset clears the BKF bit.

- 1 = Break character detected
- 0 = No break character detected

**RPF — Reception in Progress Flag Bit**

This read-only bit is set when the receiver detects a 0 during the RT1 time period of the start bit search. RPF does not generate an interrupt request. RPF is reset after the receiver detects false start bits (usually from noise or a baud rate mismatch) or when the receiver detects an idle character. Polling RPF before disabling the SCI module or entering stop mode can show whether a reception is in progress.

1 = Reception in progress

0 = No reception in progress

**18.8.6 SCI Data Register**

The SCI data register (SCDR) is the buffer between the internal data bus and the receive and transmit shift registers. Reset has no effect on data in the SCI data register.

Address: \$0018

	Bit 7	6	5	4	3	2	1	Bit 0
Read:	R7	R6	R5	R4	R3	R2	R1	R0
Write:	T7	T6	T5	T4	T3	T2	T1	T0
Reset:	Unaffected by reset							

**Figure 18-15. SCI Data Register (SCDR)****R7/T7–R0/T0 — Receive/Transmit Data Bits**

Reading address \$0018 accesses the read-only received data bits, R7:R0. Writing to address \$0018 writes the data to be transmitted, T7:T0. Reset has no effect on the SCI data register.

**NOTE**

*Do not use read/modify/write instructions on the SCI data register.*

**18.8.7 SCI Baud Rate Register**

The baud rate register (SCBR) selects the baud rate for both the receiver and the transmitter.

Address: \$0019

	Bit 7	6	5	4	3	2	1	Bit 0
Read:	0	0	SCP1	SCP0	R	SCR2	SCR1	SCR0
Write:								
Reset:	0	0	0	0	0	0	0	0

  = Unimplemented
 
R = Reserved

**Figure 18-16. SCI Baud Rate Register (SCBR)**

**SCP1 and SCP0 — SCI Baud Rate Prescaler Bits**

These read/write bits select the baud rate prescaler divisor as shown in [Table 18-6](#). Reset clears SCP1 and SCP0.

**Table 18-6. SCI Baud Rate Prescaling**

SCP1 and SCP0	Prescaler Divisor (PD)
00	1
01	3
10	4
11	13

**SCR2–SCR0 — SCI Baud Rate Select Bits**

These read/write bits select the SCI baud rate divisor as shown in [Table 18-7](#). Reset clears SCR2–SCR0.

**Table 18-7. SCI Baud Rate Selection**

SCR2, SCR1, and SCR0	Baud Rate Divisor (BD)
000	1
001	2
010	4
011	8
100	16
101	32
110	64
111	128

Use this formula to calculate the SCI baud rate:

$$\text{baud rate} = \frac{f_{\text{BUS}}}{64 \times \text{PD} \times \text{BD}}$$

where:

$f_{\text{BUS}}$  = bus frequency

PD = prescaler divisor

BD = baud rate divisor

SCIBDSRC from the configuration register is an input to the SCI. With SCIBDSRC = 1 to select the bus clock as the clock source, this makes the formula:

$$\text{baud rate} = \frac{f_{\text{BUS}}}{64 \times \text{PD} \times \text{BD}}$$

[Table 18-8](#) shows the SCI baud rates that can be generated with a 4.9152-MHz bus clock.



Table 18-8. SCI Baud Rate Selection Examples

SCP1 and SCP0	Prescaler Divisor (PD)	SCR2, SCR1, and SCR0	Baud Rate Divisor (BD)	Baud Rate ( $f_{\text{BUS}} = 4.9152 \text{ MHz}$ )
00	1	000	1	76,800
00	1	001	2	38,400
00	1	010	4	19,200
00	1	011	8	9600
00	1	100	16	4800
00	1	101	32	2400
00	1	110	64	1200
00	1	111	128	600
01	3	000	1	25,600
01	3	001	2	12,800
01	3	010	4	6400
01	3	011	8	3200
01	3	100	16	1600
01	3	101	32	800
01	3	110	64	400
01	3	111	128	200
10	4	000	1	19,200
10	4	001	2	9600
10	4	010	4	4800
10	4	011	8	2400
10	4	100	16	1200
10	4	101	32	600
10	4	110	64	300
10	4	111	128	150
11	13	000	1	5908
11	13	001	2	2954
11	13	010	4	1477
11	13	011	8	739
11	13	100	16	369
11	13	101	32	185
11	13	110	64	92
11	13	111	128	46



# Chapter 19

## System Integration Module (SIM)

### 19.1 Introduction

This section describes the system integration module (SIM). Together with the CPU, the SIM controls all MCU activities. A block diagram of the SIM is shown in [Figure 19-1](#). [Table 19-1](#) is a summary of the SIM input/output (I/O) registers. The SIM is a system state controller that coordinates CPU and exception timing. The SIM is responsible for:

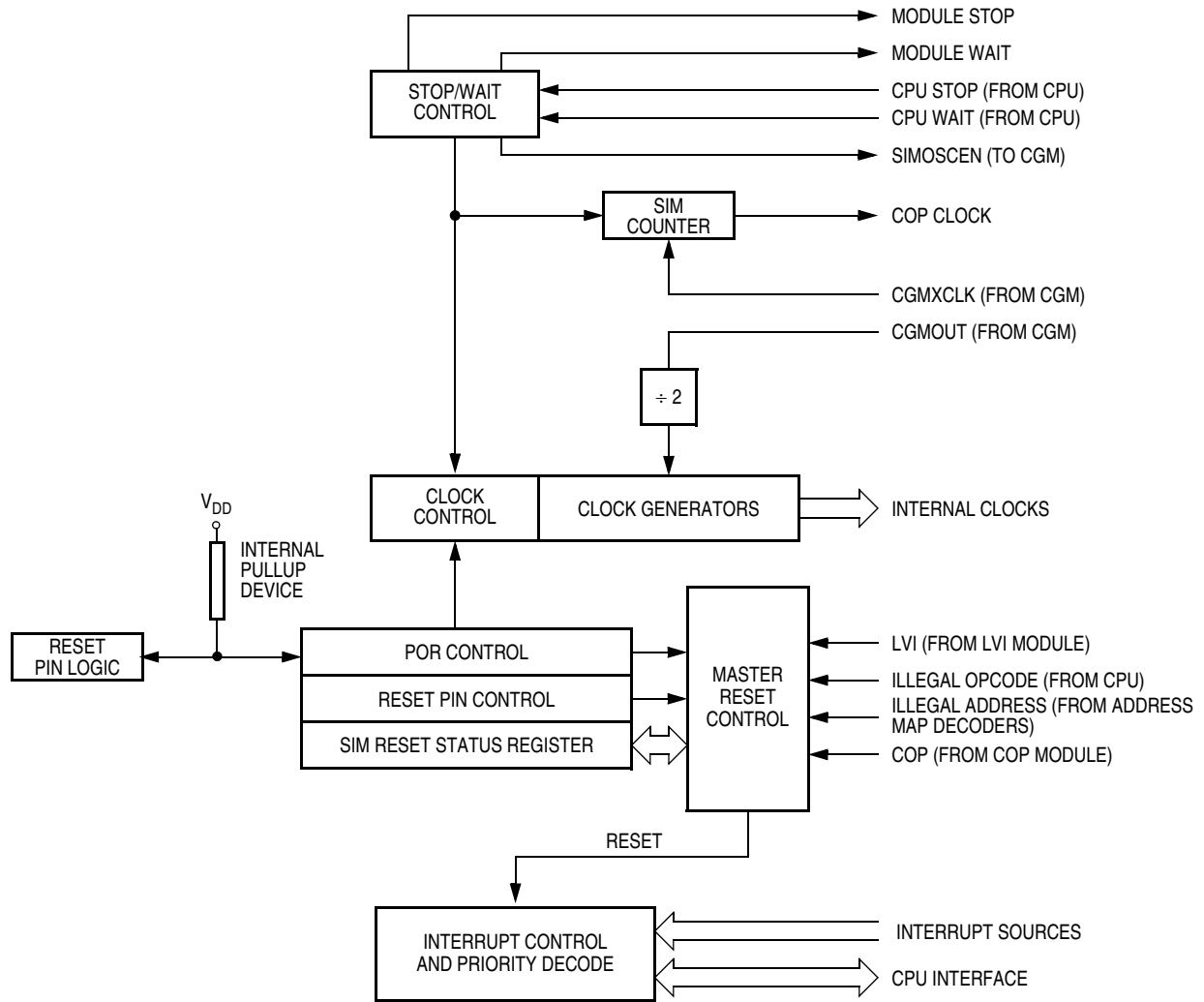
- Bus clock generation and control for CPU and peripherals:
  - Stop/wait/reset/break entry and recovery
  - Internal clock control
- Master reset control, including power-on reset (POR) and COP timeout
- Interrupt arbitration:

[Table 19-1](#) shows the internal signal names used in this section.

**Table 19-1. Signal Name Conventions**

Signal Name	Description
CGMXCLK	Buffered version of OSC1 from clock generator module (CGM)
CGMVCLK	PLL output
CGMOUT	PLL-based or OSC1-based clock output from CGM module (Bus clock = CGMOUT divided by two)
IAB	Internal address bus
IDB	Internal data bus
PORRST	Signal from the power-on reset module to the SIM
IRST	Internal reset signal
R/ $\bar{W}$	Read/write signal

# System Integration Module (SIM)



**Figure 19-1. SIM Block Diagram**

Addr.	Register Name	Bit 7	6	5	4	3	2	1	Bit 0	
\$FE00	SIM Break Status Register (SBSR)	Read:	R	R	R	R	R	SBSW	R	
		Write:						NOTE		
		Reset:	0	0	0	0	0	0	0	
Note: Writing a logic 0 clears SBSW.										
\$FE01	SIM Reset Status Register (SRSR)	Read:	POR	PIN	COP	ILOP	ILAD	MODRST	LVI	0
		Write:								
		POR:	1	0	0	0	0	0	0	0
\$FE03	SIM Break Flag Control Register (SBFCR)	Read:	BCFE	R	R	R	R	R	R	R
		Write:								
		Reset:	0							

□ = Unimplemented

**Figure 19-2. SIM I/O Register Summary**

Addr.	Register Name	Bit 7	6	5	4	3	2	1	Bit 0	
\$FE04	Interrupt Status Register 1 (INT1)	Read:	IF6	IF5	IF4	IF3	IF2	IF1	0	0
		Write:	R	R	R	R	R	R	R	R
		Reset:	0	0	0	0	0	0	0	0
\$FE05	Interrupt Status Register 2 (INT2)	Read:	IF14	IF13	IF12	IF11	IF10	IF9	IF8	IF7
		Write:	R	R	R	R	R	R	R	R
		Reset:	0	0	0	0	0	0	0	0
\$FE06	Interrupt Status Register 3 (INT3)	Read:	0	0	0	0	0	0	IF16	IF15
		Write:	R	R	R	R	R	R	R	R
		Reset:	0	0	0	0	0	0	0	0

= Unimplemented

Figure 19-2. SIM I/O Register Summary (Continued)

## 19.2 SIM Bus Clock Control and Generation

The bus clock generator provides system clock signals for the CPU and peripherals on the MCU. The system clocks are generated from an incoming clock, CGMOUT, as shown in Figure 19-3. This clock can come from either an external oscillator or from the on-chip PLL. See Chapter 7 Clock Generator Module.

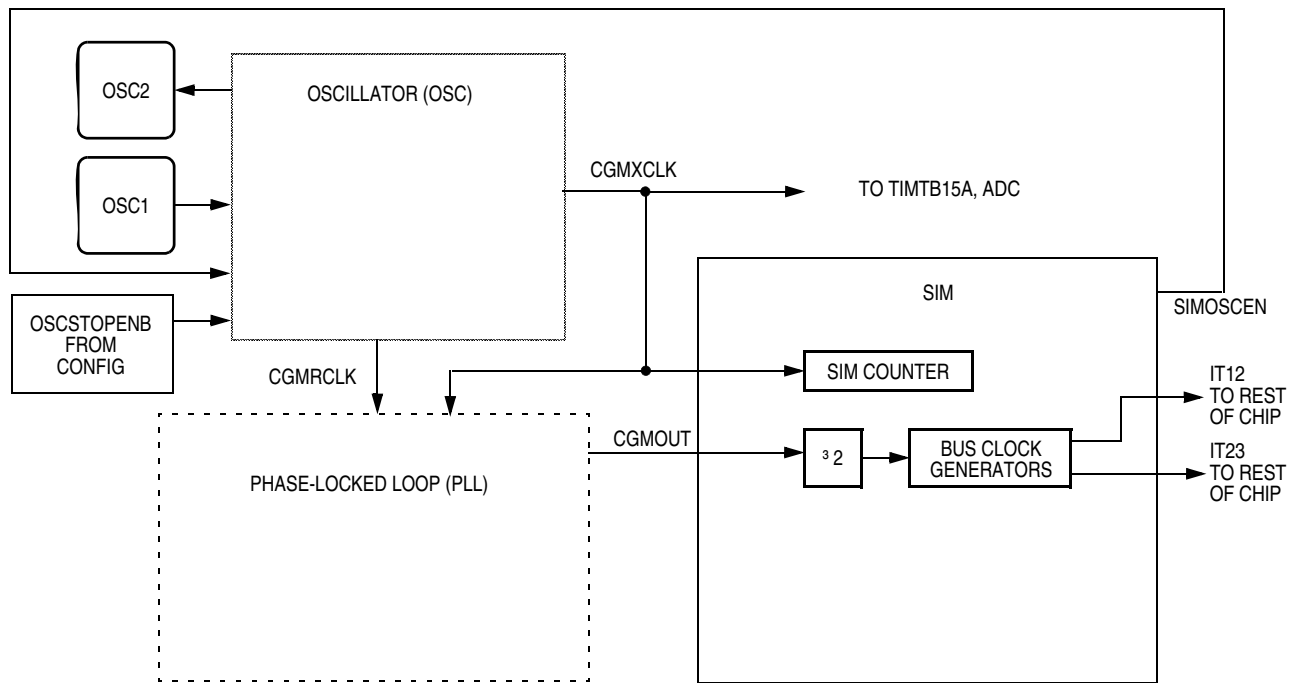


Figure 19-3. CGM Clock Signals

### 19.2.1 Bus Timing

In user mode, the internal bus frequency is either the crystal oscillator output (CGMXCLK) divided by four or the PLL output (CGMVCLK) divided by four.

### 19.2.2 Clock Startup from POR or LVI Reset

When the power-on reset module or the low-voltage inhibit module generates a reset, the clocks to the CPU and peripherals are inactive and held in an inactive phase until after the 4096 CGMXCLK cycle POR timeout has completed. The  $\overline{\text{RST}}$  pin is driven low by the SIM during this entire period. The bus clocks start upon completion of the timeout.

### 19.2.3 Clocks in Stop Mode and Wait Mode

Upon exit from stop mode by an interrupt or reset, the SIM allows CGMXCLK to clock the SIM counter. The CPU and peripheral clocks do not become active until after the stop delay timeout. This timeout is selectable as 4096 or 32 CGMXCLK cycles. See [19.6.2 Stop Mode](#).

In wait mode, the CPU clocks are inactive. The SIM also produces two sets of clocks for other modules. Refer to the wait mode subsection of each module to see if the module is active or inactive in wait mode. Some modules can be programmed to be active in wait mode.

## 19.3 Reset and System Initialization

The MCU has these reset sources:

- Power-on reset module (POR)
- External reset pin ( $\overline{\text{RST}}$ )
- Computer operating properly module (COP)
- Low-voltage inhibit module (LVI)
- Illegal opcode
- Illegal address
- Forced monitor mode entry reset (MODRST)

All of these resets produce the vector \$FFFE:\$FFFF (\$FEFE:\$FEFF in monitor mode) and assert the internal reset signal (IRST). IRST causes all registers to be returned to their default values and all modules to be returned to their reset states.

An internal reset clears the SIM counter (see [19.4 SIM Counter](#)), but an external reset does not. Each of the resets sets a corresponding bit in the SIM reset status register (SRSR). See [19.7 SIM Registers](#).

### 19.3.1 External Pin Reset

The  $\overline{\text{RST}}$  pin circuit includes an internal pullup device. Pulling the asynchronous  $\overline{\text{RST}}$  pin low halts all processing. The PIN bit of the SIM reset status register (SRSR) is set as long as  $\overline{\text{RST}}$  is held low for a minimum of 67 CGMXCLK cycles, assuming that neither the POR nor the LVI was the source of the reset. See [Table 19-2](#) for details. [Figure 19-4](#) shows the relative timing.

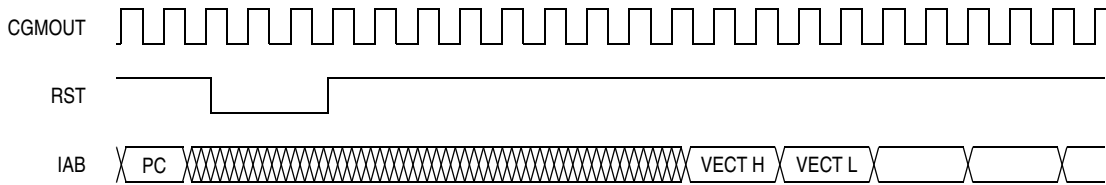


Figure 19-4. External Reset Timing

### 19.3.2 Active Resets from Internal Sources

All internal reset sources actively pull the  $\overline{RST}$  pin low for 32 CGMXCLK cycles to allow resetting of external peripherals. The internal reset signal IRST continues to be asserted for an additional 32 cycles at which point the reset vector will be fetched. See Figure 19-5. An internal reset can be caused by an illegal address, illegal opcode, COP timeout, LVI, or POR. See Figure 19-6.

**NOTE**

For LVI or POR resets, the SIM cycles through 4096 + 32 CGMXCLK cycles during which the SIM forces the  $\overline{RST}$  pin low. The internal reset signal then follows the sequence from the falling edge of  $\overline{RST}$  shown in Figure 19-5.

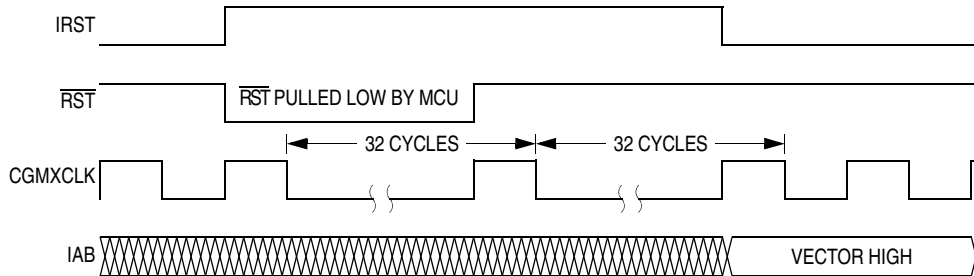


Figure 19-5. Internal Reset Timing

The COP reset is asynchronous to the bus clock.

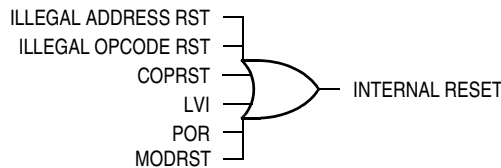


Figure 19-6. Sources of Internal Reset

Table 19-2. PIN Bit Set Timing

Reset Recovery	Actual Number of Cycles
POR/LVI	4163 (4096 + 64 + 3)
All others	67 (64 + 3)

The active reset feature allows the part to issue a reset to peripherals and other chips within a system built around the MCU.

### 19.3.2.1 Power-On Reset

When power is first applied to the MCU, the power-on reset module (POR) generates a pulse to indicate that power-on has occurred. The external reset pin ( $\overline{RST}$ ) is held low while the SIM counter counts out 4096 + 32 CGMXCLK cycles. Thirty-two CGMXCLK cycles later, the CPU and memories are released from reset to allow the reset vector sequence to occur.

At power-on, these events occur:

- A POR pulse is generated.
- The internal reset signal is asserted.
- The SIM enables CGMOUT.
- Internal clocks to the CPU and modules are held inactive for 4096 CGMXCLK cycles to allow stabilization of the oscillator.
- The  $\overline{RST}$  pin is driven low during the oscillator stabilization time.
- The POR bit of the SIM reset status register (SRSR) is set and all other bits in the register are cleared.

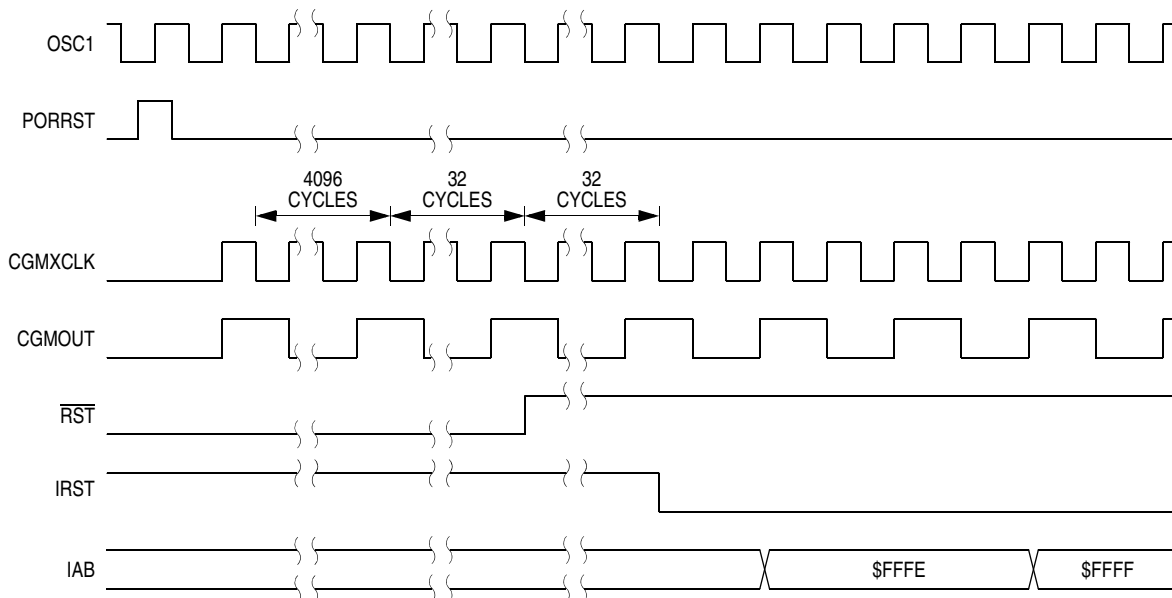


Figure 19-7. POR Recovery

### 19.3.2.2 Computer Operating Properly (COP) Reset

An input to the SIM is reserved for the COP reset signal. The overflow of the COP counter causes an internal reset and sets the COP bit in the SIM reset status register (SRSR). The SIM actively pulls down the  $\overline{RST}$  pin for all internal reset sources.

The COP module is disabled if the  $\overline{RST}$  pin or the  $\overline{IRQ}$  pin is held at  $V_{tst}$  while the MCU is in monitor mode. The COP module can be disabled only through combinational logic conditioned with the high voltage signal on the  $\overline{RST}$  or the  $\overline{IRQ}$  pin. This prevents the COP from becoming disabled as a result of external noise. During a break state,  $V_{tst}$  on the  $\overline{RST}$  pin disables the COP module.



### 19.3.2.3 Illegal Opcode Reset

The SIM decodes signals from the CPU to detect illegal instructions. An illegal instruction sets the ILOP bit in the SIM reset status register (SRSR) and causes a reset.

If the stop enable bit, STOP, in the CONFIG register is 0, the SIM treats the STOP instruction as an illegal opcode and causes an illegal opcode reset. The SIM actively pulls down the  $\overline{\text{RST}}$  pin for all internal reset sources.

### 19.3.2.4 Illegal Address Reset

An opcode fetch from an unmapped address generates an illegal address reset. The SIM verifies that the CPU is fetching an opcode prior to asserting the ILAD bit in the SIM reset status register (SRSR) and resetting the MCU. A data fetch from an unmapped address does not generate a reset. The SIM actively pulls down the  $\overline{\text{RST}}$  pin for all internal reset sources.

### 19.3.2.5 Low-Voltage Inhibit (LVI) Reset

The low-voltage inhibit module (LVI) asserts its output to the SIM when the  $V_{DD}$  voltage falls to the  $\text{LVI}_{\text{TRIPF}}$  voltage. The LVI bit in the SIM reset status register (SRSR) is set, and the external reset pin ( $\overline{\text{RST}}$ ) is held low while the SIM counter counts out  $4096 + 32 \text{ CGMXCLK}$  cycles. Thirty-two CGMXCLK cycles later, the CPU is released from reset to allow the reset vector sequence to occur. The SIM actively pulls down the  $\overline{\text{RST}}$  pin for all internal reset sources.

### 19.3.2.6 Monitor Mode Entry Module Reset (MODRST)

The monitor mode entry module reset (MODRST) asserts its output to the SIM when monitor mode is entered in the condition where the reset vectors are erased (\$FF). (See [15.3.1 Entering Monitor Mode.](#)) When MODRST gets asserted, an internal reset occurs. The SIM actively pulls down the  $\overline{\text{RST}}$  pin for all internal reset sources.

## 19.4 SIM Counter

The SIM counter is used by the power-on reset module (POR) and in stop mode recovery to allow the oscillator time to stabilize before enabling the internal bus (IBUS) clocks. The SIM counter also serves as a prescaler for the computer operating properly module (COP). The SIM counter overflow supplies the clock for the COP module. The SIM counter is 12 bits long.

### 19.4.1 SIM Counter During Power-On Reset

The power-on reset module (POR) detects power applied to the MCU. At power-on, the POR circuit asserts the signal PORRST. Once the SIM is initialized, it enables the clock generation module (CGM) to drive the bus clock state machine.

### 19.4.2 SIM Counter During Stop Mode Recovery

The SIM counter also is used for stop mode recovery. The STOP instruction clears the SIM counter. After an interrupt, break, or reset, the SIM senses the state of the short stop recovery bit, SSREC, in the CONFIG register. If the SSREC bit is a 1, then the stop recovery is reduced from the normal delay of 4096 CGMXCLK cycles down to 32 CGMXCLK cycles. This is ideal for applications using crystals with the OSCSTOPENB bit set. External crystal applications should use the full stop recovery time, that is, with SSREC cleared.

### 19.4.3 SIM Counter and Reset States

External reset has no effect on the SIM counter. (See [19.6.2 Stop Mode](#) for details.) The SIM counter is free-running after all reset states. (See [19.3.2 Active Resets from Internal Sources](#) for counter control and internal reset recovery sequences.)

## 19.5 Exception Control

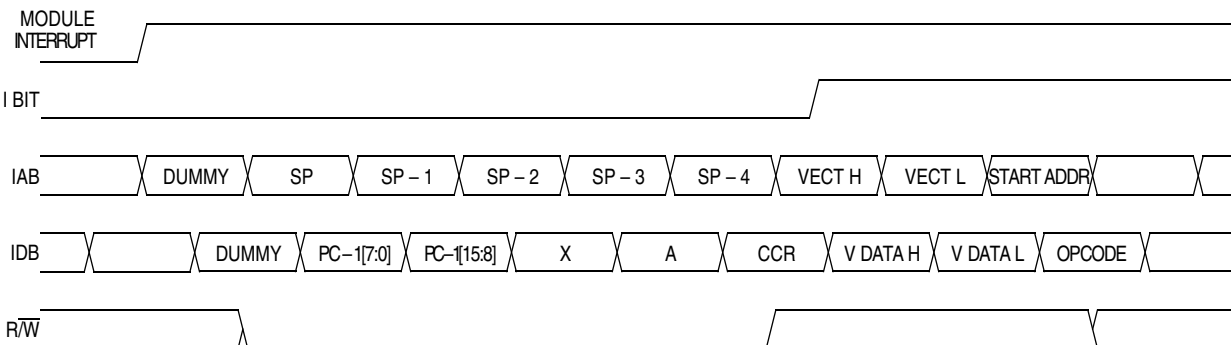
Normal, sequential program execution can be changed in three different ways:

- Interrupts:
  - Maskable hardware CPU interrupts
  - Non-maskable software interrupt instruction (SWI)
- Reset
- Break interrupts

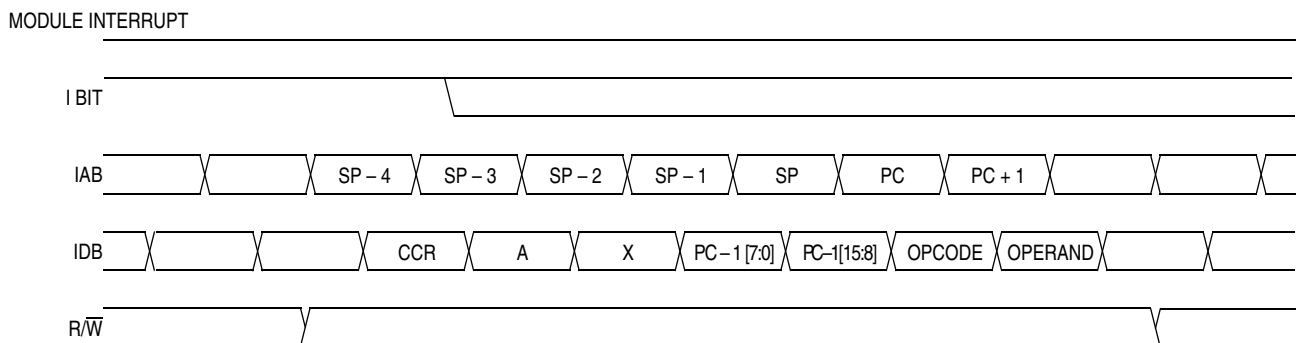
### 19.5.1 Interrupts

At the beginning of an interrupt, the CPU saves the CPU register contents on the stack and sets the interrupt mask (I bit) to prevent additional interrupts. At the end of an interrupt, the RTI instruction recovers the CPU register contents from the stack so that normal processing can resume. [Figure 19-8](#) shows interrupt entry timing. [Figure 19-9](#) shows interrupt recovery timing.

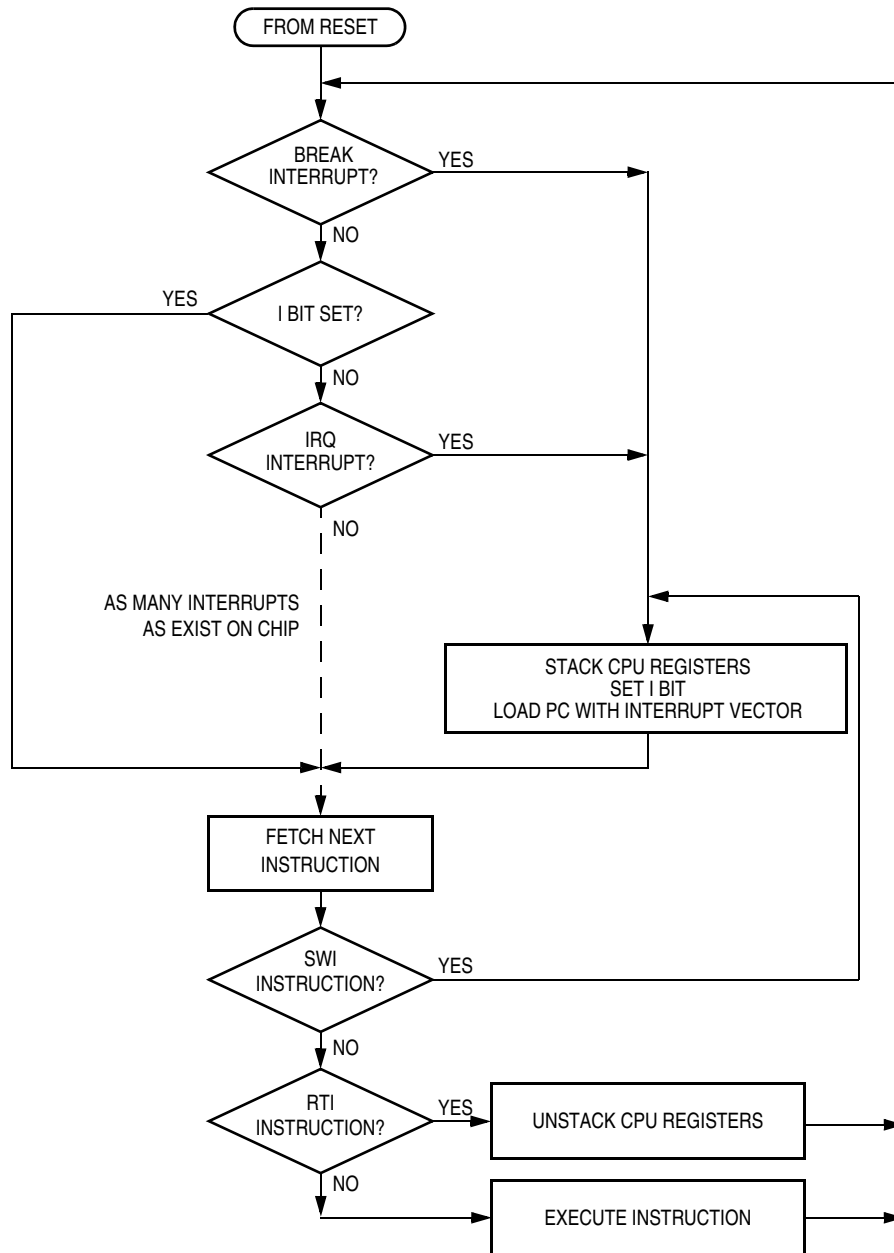
Interrupts are latched, and arbitration is performed in the SIM at the start of interrupt processing. The arbitration result is a constant that the CPU uses to determine which vector to fetch. Once an interrupt is latched by the SIM, no other interrupt can take precedence, regardless of priority, until the latched interrupt is serviced (or the I bit is cleared). See [Figure 19-10](#).



**Figure 19-8. Interrupt Entry Timing**



**Figure 19-9. Interrupt Recovery Timing**

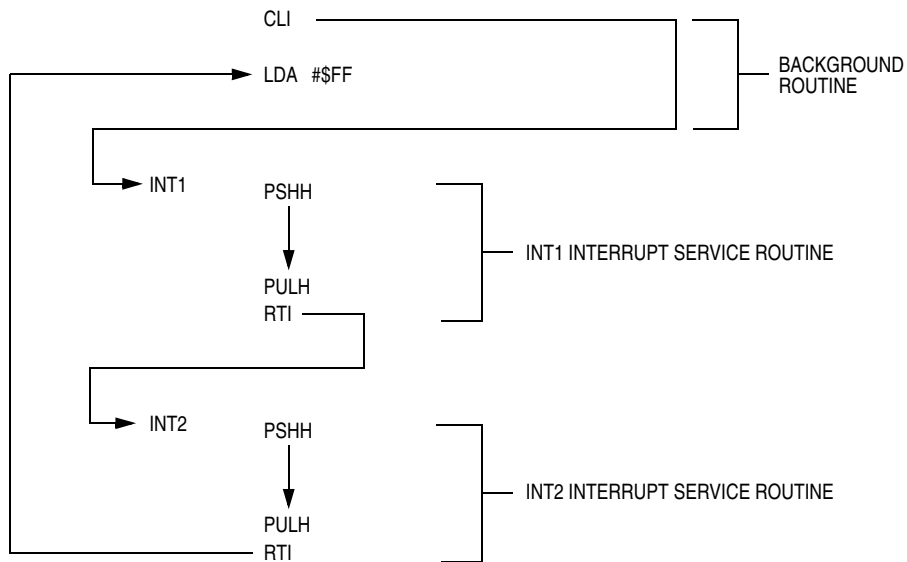


**Figure 19-10. Interrupt Processing**

### 19.5.1.1 Hardware Interrupts

A hardware interrupt does not stop the current instruction. Processing of a hardware interrupt begins after completion of the current instruction. When the current instruction is complete, the SIM checks all pending hardware interrupts. If interrupts are not masked (I bit clear in the condition code register) and if the corresponding interrupt enable bit is set, the SIM proceeds with interrupt processing; otherwise, the next instruction is fetched and executed.

If more than one interrupt is pending at the end of an instruction execution, the highest priority interrupt is serviced first. Figure 19-11 demonstrates what happens when two interrupts are pending. If an interrupt is pending upon exit from the original interrupt service routine, the pending interrupt is serviced before the LDA instruction is executed.



**Figure 19-11. Interrupt Recognition Example**

The LDA opcode is prefetched by both the INT1 and INT2 RTI instructions. However, in the case of the INT1 RTI prefetch, this is a redundant operation.

**NOTE**

*To maintain compatibility with the M6805 Family, the H register is not pushed on the stack during interrupt entry. If the interrupt service routine modifies the H register or uses the indexed addressing mode, software should save the H register and then restore it prior to exiting the routine.*

### 19.5.1.2 SWI Instruction

The SWI instruction is a non-maskable instruction that causes an interrupt regardless of the state of the interrupt mask (I bit) in the condition code register.


**NOTE**

*A software interrupt pushes PC onto the stack. A software interrupt does not push PC – 1, as a hardware interrupt does.*

### 19.5.1.3 Interrupt Status Registers

The flags in the interrupt status registers identify maskable interrupt sources. [Table 19-3](#) summarizes the interrupt sources and the interrupt status register flags that they set. The interrupt status registers can be useful for debugging.

**Table 19-3. Interrupt Sources**

Priority	Interrupt Source	Interrupt Status Register Flag
Highest  Lowest	Reset	—
	SWI instruction	—
	IRQ pin	I1
	PLL	I2
	TIM1 channel 0	I3
	TIM1 channel 1	I4
	TIM1 overflow	I5
	TIM2 channel 0	I6
	Reserved	I7
	TIM2 overflow	I8
	SPI receiver full	I9
	SPI transmitter empty	I10
	SCI receive error	I11
	SCI receive	I12
	SCI transmit	I13
	Keyboard	I14
ADC conversion complete	I15	
Timebase module	I16	

### 19.5.1.4 Interrupt Status Register 1

Address: \$FE04

	Bit 7	6	5	4	3	2	1	Bit 0
Read:	I6	I5	I4	I3	I2	I1	0	0
Write:	R	R	R	R	R	R	R	R
Reset:	0	0	0	0	0	0	0	0

R = Reserved

**Figure 19-12. Interrupt Status Register 1 (INT1)**

#### I6–I1 — Interrupt Flags 1–6

These flags indicate the presence of interrupt requests from the sources shown in [Table 19-3](#).

1 = Interrupt request present

0 = No interrupt request present

#### Bit 0 and Bit 1 — Always read 0

### 19.5.1.5 Interrupt Status Register 2

Address: \$FE05

	Bit 7	6	5	4	3	2	1	Bit 0
Read:	IF14	IF13	IF12	IF11	IF10	IF9	IF8	0
Write:	R	R	R	R	R	R	R	R
Reset:	0	0	0	0	0	0	0	0

R = Reserved

**Figure 19-13. Interrupt Status Register 2 (INT2)**

#### IF14–IF8 — Interrupt Flags 14–7

These flags indicate the presence of interrupt requests from the sources shown in [Table 19-3](#).

- 1 = Interrupt request present
- 0 = No interrupt request present

#### Bit 0 — Always reads 0

### 19.5.1.6 Interrupt Status Register 3

Address: \$FE06

	Bit 7	6	5	4	3	2	1	Bit 0
Read:	0	0	0	0	0	0	I16	I15
Write:	R	R	R	R	R	R	R	R
Reset:	0	0	0	0	0	0	0	0

R = Reserved

**Figure 19-14. Interrupt Status Register 3 (INT3)**

#### Bits 7–2 — Always read 0

#### I16–I15 — Interrupt Flags 16–15

These flags indicate the presence of an interrupt request from the source shown in [Table 19-3](#).

- 1 = Interrupt request present
- 0 = No interrupt request present

## 19.5.2 Reset

All reset sources always have equal and highest priority and cannot be arbitrated.

## 19.5.3 Break Interrupts

The break module can stop normal program flow at a software-programmable break point by asserting its break interrupt output. See [Chapter 22 Timer Interface Module \(TIM\)](#). The SIM puts the CPU into the break state by forcing it to the SWI vector location. Refer to the break interrupt subsection of each module to see how each module is affected by the break state.

### 19.5.4 Status Flag Protection in Break Mode

The SIM controls whether status flags contained in other modules can be cleared during break mode. The user can select whether flags are protected from being cleared by properly initializing the break clear flag enable bit (BCFE) in the SIM break flag control register (SBFCR).

Protecting flags in break mode ensures that set flags will not be cleared while in break mode. This protection allows registers to be freely read and written during break mode without losing status flag information.

Setting the BCFE bit enables the clearing mechanisms. Once cleared in break mode, a flag remains cleared even when break mode is exited. Status flags with a 2-step clearing mechanism — for example, a read of one register followed by the read or write of another — are protected, even when the first step is accomplished prior to entering break mode. Upon leaving break mode, execution of the second step will clear the flag as normal.

## 19.6 Low-Power Modes

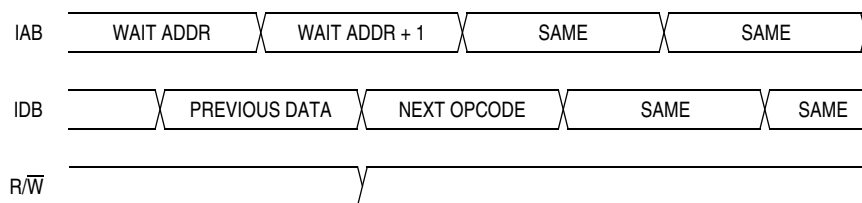
Executing the WAIT or STOP instruction puts the MCU in a low power-consumption mode for standby situations. The SIM holds the CPU in a non-clocked state. The operation of each of these modes is described in the following subsections. Both STOP and WAIT clear the interrupt mask (I) in the condition code register, allowing interrupts to occur.

### 19.6.1 Wait Mode

In wait mode, the CPU clocks are inactive while the peripheral clocks continue to run. [Figure 19-15](#) shows the timing for wait mode entry.

A module that is active during wait mode can wake up the CPU with an interrupt if the interrupt is enabled. Stacking for the interrupt begins one cycle after the WAIT instruction during which the interrupt occurred. In wait mode, the CPU clocks are inactive. Refer to the wait mode subsection of each module to see if the module is active or inactive in wait mode. Some modules can be programmed to be active in wait mode.

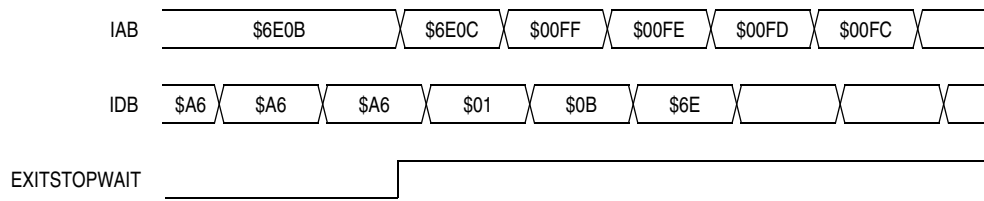
Wait mode also can be exited by a reset or break in emulation mode. A break interrupt during wait mode sets the SIM break stop/wait bit, SBSW, in the SIM break status register (SBSR). If the COP disable bit, COPD, in the CONFIG register is 0, then the computer operating properly module (COP) is enabled and remains active in wait mode.



Note: Previous data can be operand data or the WAIT opcode, depending on the last instruction.

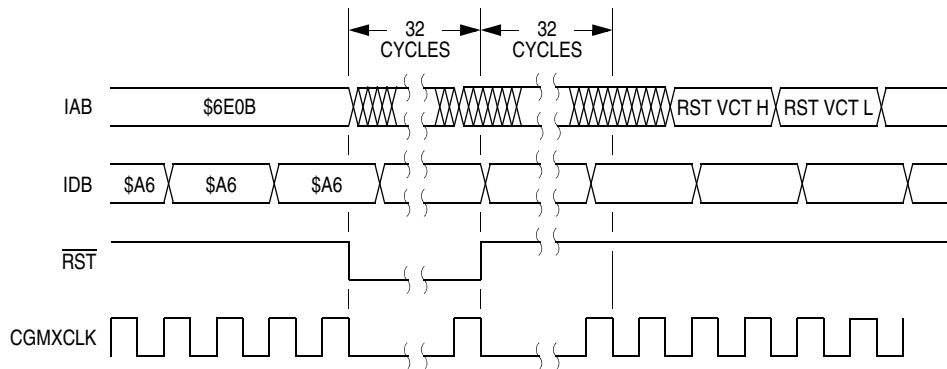
**Figure 19-15. Wait Mode Entry Timing**

Figure 19-16 and Figure 19-17 show the timing for WAIT recovery.



Note: EXITSTOPWAIT =  $\overline{\text{RST}}$  pin, CPU interrupt, or break interrupt

**Figure 19-16. Wait Recovery from Interrupt or Break**



**Figure 19-17. Wait Recovery from Internal Reset**

### 19.6.2 Stop Mode

In stop mode, the SIM counter is reset and the system clocks are disabled. An interrupt request from a module can cause an exit from stop mode. Stacking for interrupts begins after the selected stop recovery time has elapsed. Reset or break also causes an exit from stop mode.

The SIM disables the clock generator module outputs (CGMOUT and CGMXCLK) in stop mode, stopping the CPU and peripherals. Stop recovery time is selectable using the SSREC bit in the CONFIG register (MOR). If SSREC is set, stop recovery is reduced from the normal delay of 4096 CGMXCLK cycles down to 32. This is ideal for applications using canned oscillators that do not require long startup times from stop mode.

**NOTE**

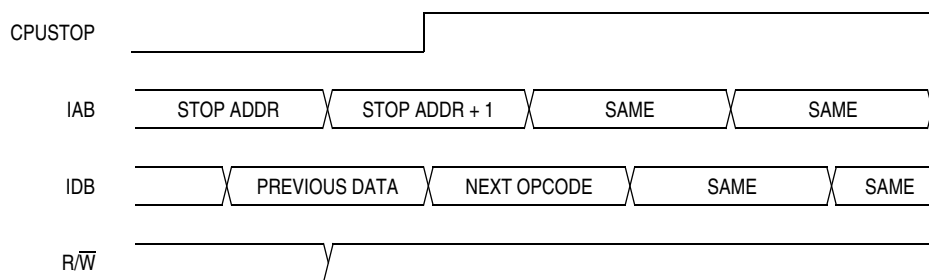
*External crystal applications should use the full stop recovery time by clearing the SSREC bit unless the OSCSTOPENB bit is set in the configuration register.*

The SIM counter is held in reset from the execution of the STOP instruction until the beginning of stop recovery. It is then used to time the recovery period. Figure 19-18 shows stop mode entry timing.

**NOTE**

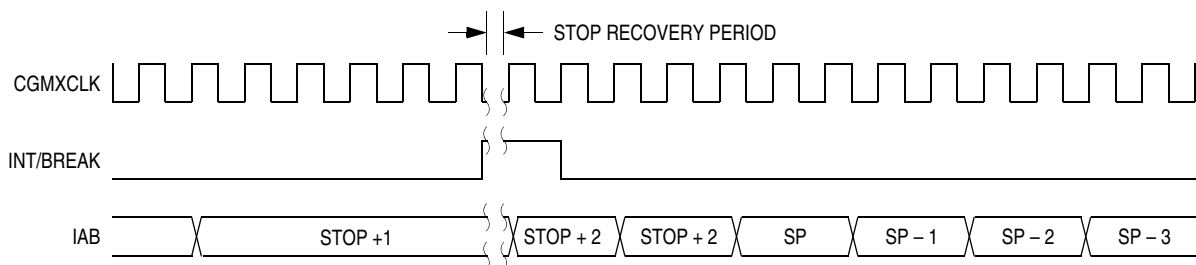
*To minimize stop current, all pins configured as inputs should be driven to a 1 or 0.*





Note : Previous data can be operand data or the STOP opcode, depending on the last instruction.

**Figure 19-18. Stop Mode Entry Timing**



**Figure 19-19. Stop Mode Recovery from Interrupt or Break**

## 19.7 SIM Registers

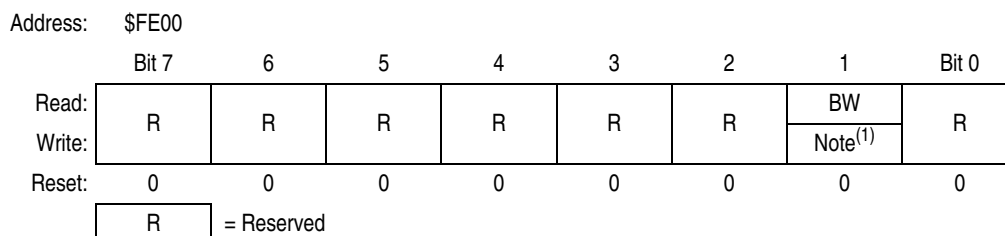
The SIM has three memory-mapped registers. [Table 19-4](#) shows the mapping of these registers.

**Table 19-4. SIM Registers**

Address	Register	Access Mode
\$FE00	SBSR	User
\$FE01	SRSR	User
\$FE03	SBFCR	User

### 19.7.1 SIM Break Status Register

The SIM break status register (SBSR) contains a flag to indicate that a break caused an exit from wait mode



Note: 1. Writing a logic 0 clears SBSW.

**Figure 19-20. SIM Break Status Register (SBSR)**

**BW — SIM Break Wait**

Clear BW by writing a 0 to it. Reset clears BW. BW can be read within the break state SWI routine. The user can modify the return address on the stack by subtracting one from it.


- 1 = Wait mode was exited by break interrupt.
- 0 = Wait mode was not exited by break interrupt.

**19.7.2 SIM Reset Status Register**

The SRSR register contains flags that show the source of the last reset. The status register will automatically clear after reading SRSR. A power-on reset sets the POR bit and clears all other bits in the register. All other reset sources set the individual flag bits but do not clear the register. More than one reset source can be flagged at any time depending on the conditions at the time of the internal or external reset. For example, the POR and LVI bit can both be set if the power supply has a slow rise time.

Address: \$FE01

	Bit 7	6	5	4	3	2	1	Bit 0
Read:	POR	PIN	COP	ILOP	ILAD	MODRST	LVI	0
Write:								
Reset:	1	0	0	0	0	0	0	0

 = Unimplemented

**Figure 19-21. SIM Reset Status Register (SRSR)****POR — Power-On Reset Bit**

- 1 = Last reset caused by POR circuit
- 0 = Read of SRSR

**PIN — External Reset Bit**

- 1 = Last reset caused by external reset pin ( $\overline{RST}$ )
- 0 = POR or read of SRSR

**COP — Computer Operating Properly Reset Bit**

- 1 = Last reset caused by COP counter
- 0 = POR or read of SRSR

**ILOP — Illegal Opcode Reset Bit**

- 1 = Last reset caused by an illegal opcode
- 0 = POR or read of SRSR

**ILAD — Illegal Address Reset Bit (opcode fetches only)**

- 1 = Last reset caused by an opcode fetch from an illegal address
- 0 = POR or read of SRSR

**MODRST — Monitor Mode Entry Module Reset Bit**

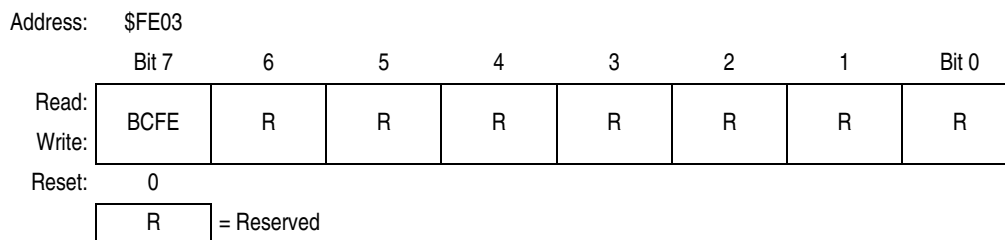
- 1 = Last reset caused by monitor mode entry when vector locations \$FFFE and \$FFFF are \$FF after POR while  $\overline{IRQ} = V_{DD}$
- 0 = POR or read of SRSR

**LVI — Low-Voltage Inhibit Reset Bit**

- 1 = Last reset caused by the LVI circuit
- 0 = POR or read of SRSR

### 19.7.3 SIM Break Flag Control Register

The SIM break control register contains a bit that enables software to clear status bits while the MCU is in a break state.



**Figure 19-22. SIM Break Flag Control Register (SBFCR)**

#### BCFE — Break Clear Flag Enable Bit

This read/write bit enables software to clear status bits by accessing status registers while the MCU is in a break state. To clear status bits during the break state, the BCFE bit must be set.

1 = Status bits clearable during break

0 = Status bits not clearable during break



# Chapter 20

## Serial Peripheral Interface (SPI)

### 20.1 Introduction

This section describes the serial peripheral interface (SPI) module, which allows full-duplex, synchronous, serial communications with peripheral devices.

### 20.2 Features

Features of the SPI module include:

- Full-duplex operation
- Master and slave modes
- Double-buffered operation with separate transmit and receive registers
- Four master mode frequencies (maximum = bus frequency  $\div$  2)
- Maximum slave mode frequency = bus frequency
- Serial clock with programmable polarity and phase
- Two separately enabled interrupts:
  - SPRF (SPI receiver full)
  - SPTE (SPI transmitter empty)
- Mode fault error flag with CPU interrupt capability
- Overflow error flag with CPU interrupt capability
- Programmable wired-OR mode
- I/O (input/output) port bit(s) software configurable with pullup device(s) if configured as input port bit(s)

### 20.3 Pin Name Conventions and I/O Register Addresses

The text that follows describes the SPI. The SPI I/O pin names are  $\overline{SS}$  (slave select), SPSCCK (SPI serial clock), MOSI (master out slave in), and MISO (master in/slave out). The SPI shares four I/O pins with four parallel I/O ports.

The full names of the SPI I/O pins are shown in [Table 20-1](#). The generic pin names appear in the text that follows.

**Table 20-1. Pin Name Conventions**

SPI Generic Pin Names:		MISO	MOSI	$\overline{SS}$	SPSCCK	CGND
Full SPI Pin Names:	SPI	PTD1/ATD9	PTD2/ATD10	PTD0/ATD8	PTD3/ATD11	V <sub>SS</sub>

### 20.4 Functional Description

[Figure 20-1](#) summarizes the SPI I/O registers and [Figure 20-2](#) shows the structure of the SPI module.

Addr.	Register Name	Bit 7	6	5	4	3	2	1	Bit 0	
\$0010	SPI Control Register (SPCR)	Read:	SPRIE	R	SPMSTR	CPOL	CPHA	SPWOM	SPE	SPTIE
		Write:								
		Reset:	0	0	1	0	1	0	0	0
\$0011	SPI Status and Control Register (SPSCR)	Read:	SPRF	ERRIE	OVRF	MODF	SPTIE	MODFEN	SPR1	SPR0
		Write:								
		Reset:	0	0	0	0	1	0	0	0
\$0012	SPI Data Register (SPDR)	Read:	R7	R6	R5	R4	R3	R2	R1	R0
		Write:	T7	T6	T5	T4	T3	T2	T1	T0
		Reset:	Unaffected by reset							

= Unimplemented     
 R = Reserved

**Figure 20-1. SPI I/O Register Summary**

The SPI module allows full-duplex, synchronous, serial communication between the MCU and peripheral devices, including other MCUs. Software can poll the SPI status flags or SPI operation can be interrupt-driven.

If a port bit is configured for input, then an internal pullup device may be enabled for that port bit. See [16.5.3 Port D Input Pullup Enable Register](#).

The following paragraphs describe the operation of the SPI module.

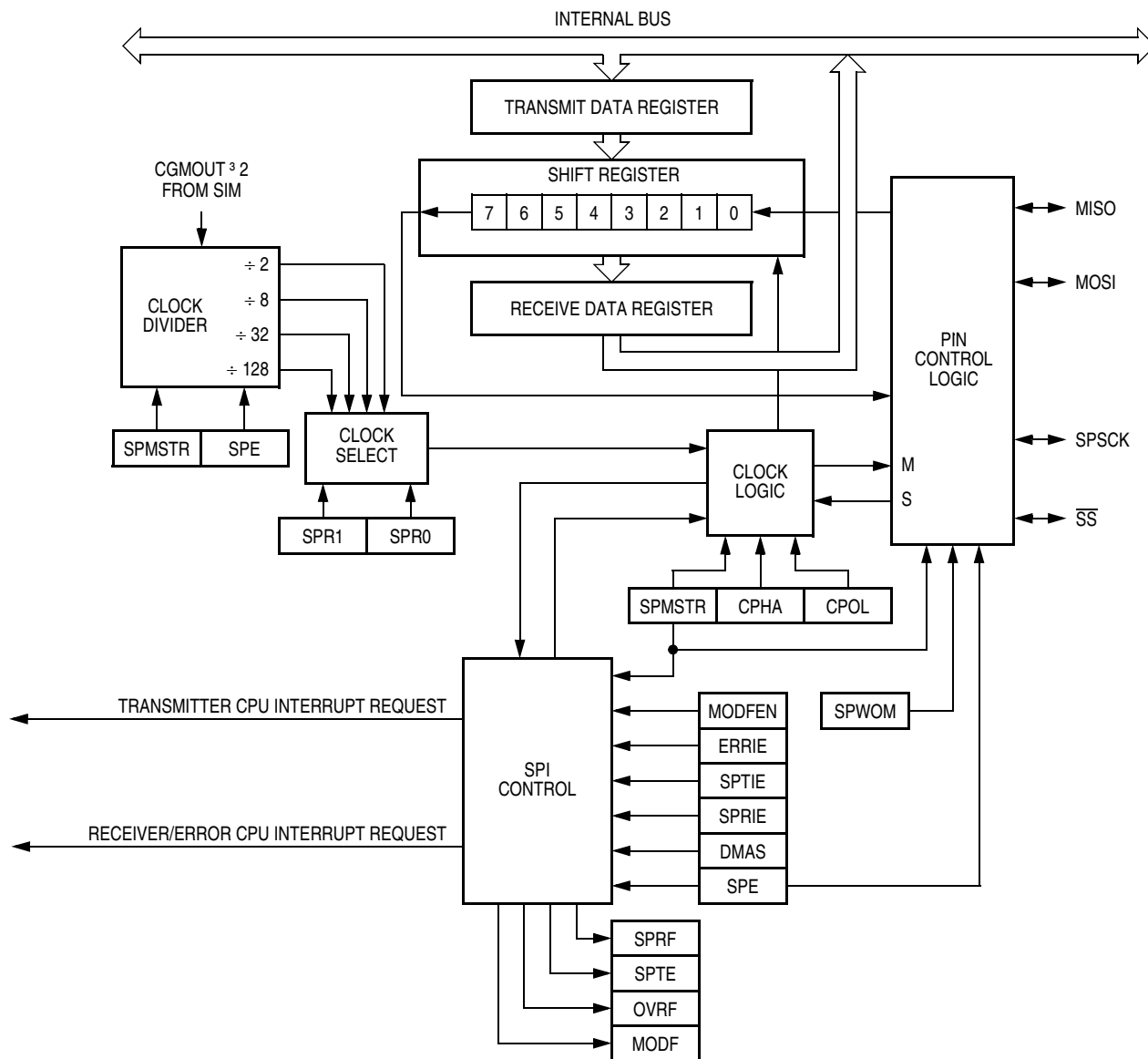


Figure 20-2. SPI Module Block Diagram

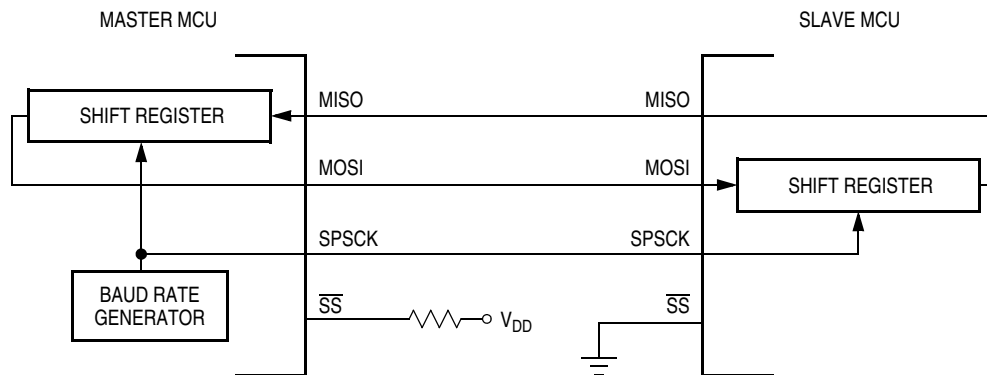
### 20.4.1 Master Mode

The SPI operates in master mode when the SPI master bit, SPMSTR, is set.

#### NOTE

*Configure the SPI modules as master or slave before enabling them. Enable the master SPI before enabling the slave SPI. Disable the slave SPI before disabling the master SPI. See [20.13.1 SPI Control Register](#).*

Only a master SPI module can initiate transmissions. Software begins the transmission from a master SPI module by writing to the transmit data register. If the shift register is empty, the byte immediately transfers to the shift register, setting the SPI transmitter empty bit, SPTE. The byte begins shifting out on the MOSI pin under the control of the serial clock. See [Figure 20-3](#).



**Figure 20-3. Full-Duplex Master-Slave Connections**

The SPR1 and SPR0 bits control the baud rate generator and determine the speed of the shift register. See [20.13.2 SPI Status and Control Register](#). Through the SPSCCK pin, the baud rate generator of the master also controls the shift register of the slave peripheral.

As the byte shifts out on the MOSI pin of the master, another byte shifts in from the slave on the master's MISO pin. The transmission ends when the receiver full bit, SPRF, becomes set. At the same time that SPRF becomes set, the byte from the slave transfers to the receive data register. In normal operation, SPRF signals the end of a transmission. Software clears SPRF by reading the SPI status and control register with SPRF set and then reading the SPI data register. Writing to the SPI data register clears the SPTE bit.

### 20.4.2 Slave Mode

The SPI operates in slave mode when the SPMSTR bit is clear. In slave mode, the SPSCCK pin is the input for the serial clock from the master MCU. Before a data transmission occurs, the SS pin of the slave SPI must be at logic 0. SS must remain low until the transmission is complete. See [20.7.2 Mode Fault Error](#).

In a slave SPI module, data enters the shift register under the control of the serial clock from the master SPI module. After a byte enters the shift register of a slave SPI, it transfers to the receive data register, and the SPRF bit is set. To prevent an overflow condition, slave software then must read the receive data register before another full byte enters the shift register.

The maximum frequency of the SPSCCK for an SPI configured as a slave is the bus clock speed (which is twice as fast as the fastest master SPSCCK clock that can be generated). The frequency of the SPSCCK for an SPI configured as a slave does not have to correspond to any SPI baud rate. The baud rate only



controls the speed of the SPSCCK generated by an SPI configured as a master. Therefore, the frequency of the SPSCCK for an SPI configured as a slave can be any frequency less than or equal to the bus speed.

When the master SPI starts a transmission, the data in the slave shift register begins shifting out on the MISO pin. The slave can load its shift register with a new byte for the next transmission by writing to its transmit data register. The slave must write to its transmit data register at least one bus cycle before the master starts the next transmission. Otherwise, the byte already in the slave shift register shifts out on the MISO pin. Data written to the slave shift register during a transmission remains in a buffer until the end of the transmission.

When the clock phase bit (CPHA) is set, the first edge of SPSCCK starts a transmission. When CPHA is clear, the falling edge of  $\overline{SS}$  starts a transmission. See [20.5 Transmission Formats](#).

**NOTE**

*SPSCCK must be in the proper idle state before the slave is enabled to prevent SPSCCK from appearing as a clock edge.*

## 20.5 Transmission Formats

During an SPI transmission, data is simultaneously transmitted (shifted out serially) and received (shifted in serially). A serial clock synchronizes shifting and sampling on the two serial data lines. A slave select line allows selection of an individual slave SPI device; slave devices that are not selected do not interfere with SPI bus activities. On a master SPI device, the slave select line can optionally be used to indicate multiple-master bus contention.

### 20.5.1 Clock Phase and Polarity Controls

Software can select any of four combinations of serial clock (SPSCCK) phase and polarity using two bits in the SPI control register (SPCR). The clock polarity is specified by the CPOL control bit, which selects an active high or low clock and has no significant effect on the transmission format.

The clock phase (CPHA) control bit selects one of two fundamentally different transmission formats. The clock phase and polarity should be identical for the master SPI device and the communicating slave device. In some cases, the phase and polarity are changed between transmissions to allow a master device to communicate with peripheral slaves having different requirements.

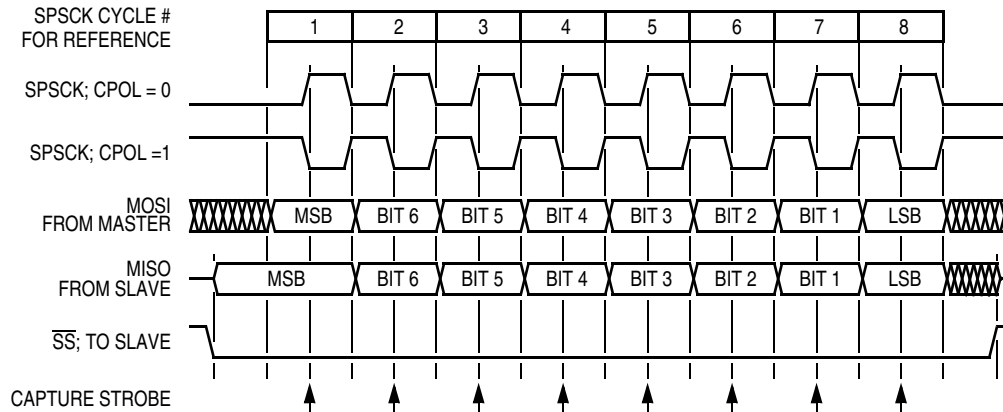
**NOTE**

*Before writing to the CPOL bit or the CPHA bit, disable the SPI by clearing the SPI enable bit (SPE).*

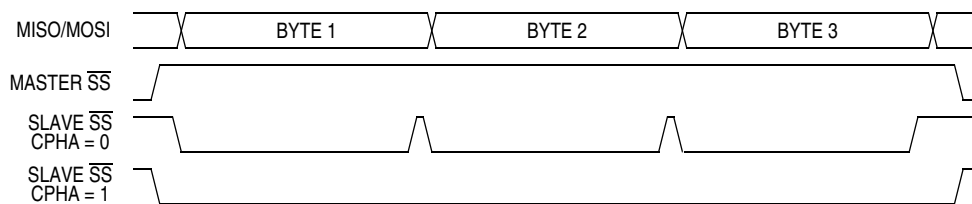
### 20.5.2 Transmission Format When CPHA = 0

[Figure 20-4](#) shows an SPI transmission in which CPHA is logic 0. The figure should not be used as a replacement for data sheet parametric information.

## Serial Peripheral Interface (SPI)



**Figure 20-4. Transmission Format (CPHA = 0)**



**Figure 20-5. CPHA/SS Timing**

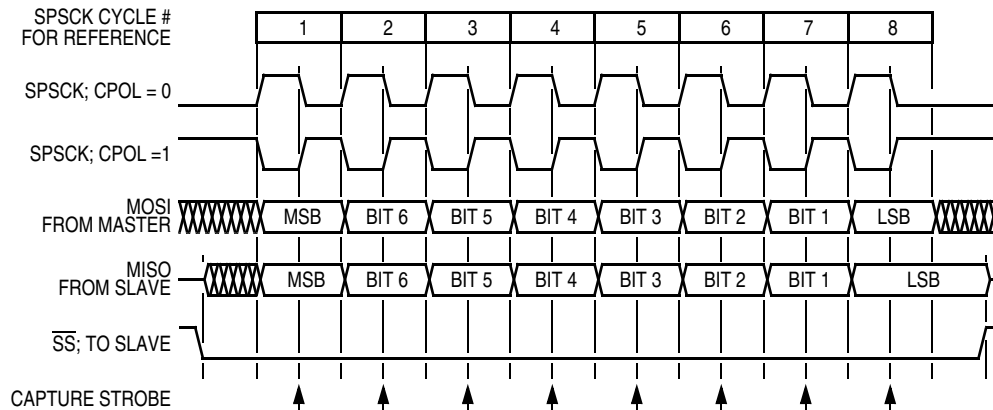
Two waveforms are shown for SPSCK: one for CPOL = 0 and another for CPOL = 1. The diagram may be interpreted as a master or slave timing diagram since the serial clock (SPSCK), master in/slave out (MISO), and master out/slave in (MOSI) pins are directly connected between the master and the slave. The MISO signal is the output from the slave, and the MOSI signal is the output from the master. The  $\overline{SS}$  line is the slave select input to the slave. The slave SPI drives its MISO output only when its slave select input ( $\overline{SS}$ ) is at 0, so that only the selected slave drives to the master. The  $\overline{SS}$  pin of the master is not shown but is assumed to be inactive. The  $\overline{SS}$  pin of the master must be high or must be reconfigured as general-purpose I/O not affecting the SPI. See [20.7.2 Mode Fault Error](#). When CPHA = 0, the first SPSCK edge is the MSB capture strobe. Therefore, the slave must begin driving its data before the first SPSCK edge, and a falling edge on the  $\overline{SS}$  pin is used to start the slave data transmission. The slave's  $\overline{SS}$  pin must be toggled back to high and then low again between each byte transmitted as shown in [Figure 20-5](#).

When CPHA = 0 for a slave, the falling edge of  $\overline{SS}$  indicates the beginning of the transmission. This causes the SPI to leave its idle state and begin driving the MISO pin with the MSB of its data. Once the transmission begins, no new data is allowed into the shift register from the transmit data register. Therefore, the SPI data register of the slave must be loaded with transmit data before the falling edge of  $\overline{SS}$ . Any data written after the falling edge is stored in the transmit data register and transferred to the shift register after the current transmission.

### 20.5.3 Transmission Format When CPHA = 1

[Figure 20-6](#) shows an SPI transmission in which CPHA is logic 1. The figure should not be used as a replacement for data sheet parametric information. Two waveforms are shown for SPSCK: one for CPOL = 0 and another for CPOL = 1. The diagram may be interpreted as a master or slave timing diagram since the serial clock (SPSCK), master in/slave out (MISO), and master out/slave in (MOSI) pins are directly connected between the master and the slave. The MISO signal is the output from the slave, and the MOSI signal is the output from the master. The  $\overline{SS}$  line is the slave select input to the slave. The

slave SPI drives its MISO output only when its slave select input ( $\overline{SS}$ ) is at logic 0, so that only the selected slave drives to the master. The  $\overline{SS}$  pin of the master is not shown but is assumed to be inactive. The  $\overline{SS}$  pin of the master must be high or must be reconfigured as general-purpose I/O not affecting the SPI. See [20.7.2 Mode Fault Error](#). When  $CPHA = 1$ , the master begins driving its MOSI pin on the first SPSCCK edge. Therefore, the slave uses the first SPSCCK edge as a start transmission signal. The  $\overline{SS}$  pin can remain low between transmissions. This format may be preferable in systems having only one master and only one slave driving the MISO data line.



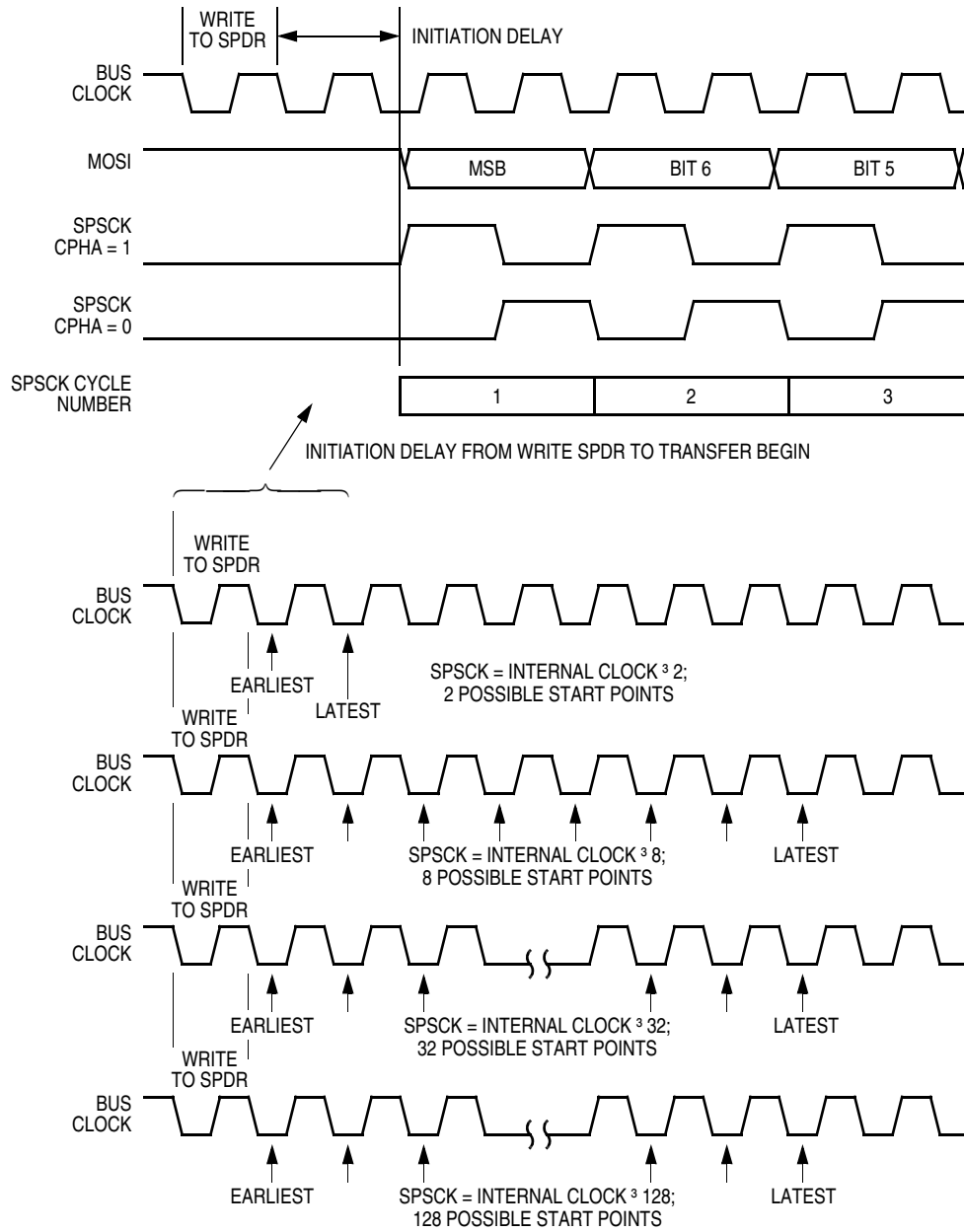
**Figure 20-6. Transmission Format ( $CPHA = 1$ )**

When  $CPHA = 1$  for a slave, the first edge of the SPSCCK indicates the beginning of the transmission. This causes the SPI to leave its idle state and begin driving the MISO pin with the MSB of its data. Once the transmission begins, no new data is allowed into the shift register from the transmit data register. Therefore, the SPI data register of the slave must be loaded with transmit data before the first edge of SPSCCK. Any data written after the first edge is stored in the transmit data register and transferred to the shift register after the current transmission.

### 20.5.4 Transmission Initiation Latency

When the SPI is configured as a master ( $SPMSTR = 1$ ), writing to the SPDR starts a transmission.  $CPHA$  has no effect on the delay to the start of the transmission, but it does affect the initial state of the SPSCCK signal. When  $CPHA = 0$ , the SPSCCK signal remains inactive for the first half of the first SPSCCK cycle. When  $CPHA = 1$ , the first SPSCCK cycle begins with an edge on the SPSCCK line from its inactive to its active level. The SPI clock rate (selected by  $SPR1:SPR0$ ) affects the delay from the write to SPDR and the start of the SPI transmission. See [Figure 20-7](#). The internal SPI clock in the master is a free-running derivative of the internal MCU clock. To conserve power, it is enabled only when both the SPE and SPMSTR bits are set. Since the SPI clock is free-running, it is uncertain where the write to the SPDR occurs relative to the slower SPSCCK. This uncertainty causes the variation in the initiation delay shown in [Figure 20-7](#). This delay is no longer than a single SPI bit time. That is, the maximum delay is two MCU bus cycles for DIV2, eight MCU bus cycles for DIV8, 32 MCU bus cycles for DIV32, and 128 MCU bus cycles for DIV128.

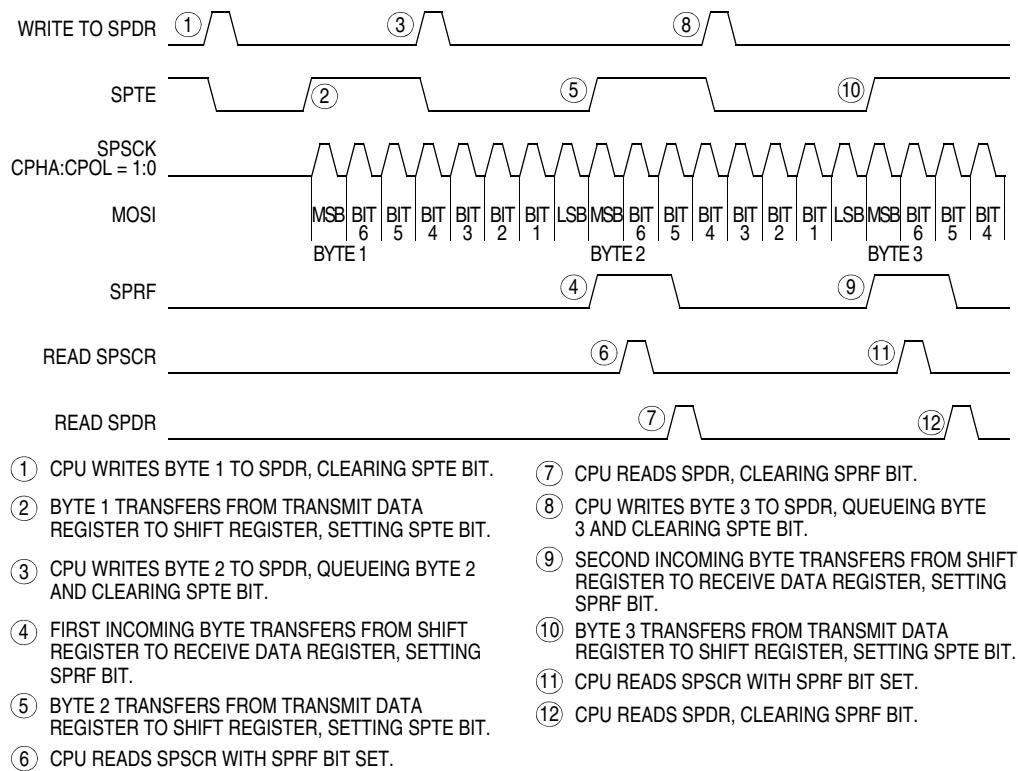
## Serial Peripheral Interface (SPI)



**Figure 20-7. Transmission Start Delay (Master)**

## 20.6 Queuing Transmission Data

The double-buffered transmit data register allows a data byte to be queued and transmitted. For an SPI configured as a master, a queued data byte is transmitted immediately after the previous transmission has completed. The SPI transmitter empty flag (SPTE) indicates when the transmit data buffer is ready to accept new data. Write to the transmit data register only when the SPTE bit is high. Figure 20-8 shows the timing associated with doing back-to-back transmissions with the SPI (SPSCK has CPHA:CPOL = 1:0).



**Figure 20-8. SPRF/SPTE CPU Interrupt Timing**

The transmit data buffer allows back-to-back transmissions without the slave precisely timing its writes between transmissions as in a system with a single data buffer. Also, if no new data is written to the data buffer, the last value contained in the shift register is the next data word to be transmitted.

For an idle master or idle slave that has no data loaded into its transmit buffer, the SPTE is set again no more than two bus cycles after the transmit buffer empties into the shift register. This allows the user to queue up a 16-bit value to send. For an already active slave, the load of the shift register cannot occur until the transmission is completed. This implies that a back-to-back write to the transmit data register is not possible. The SPTE indicates when the next write can occur.

## 20.7 Error Conditions

The following flags signal SPI error conditions:

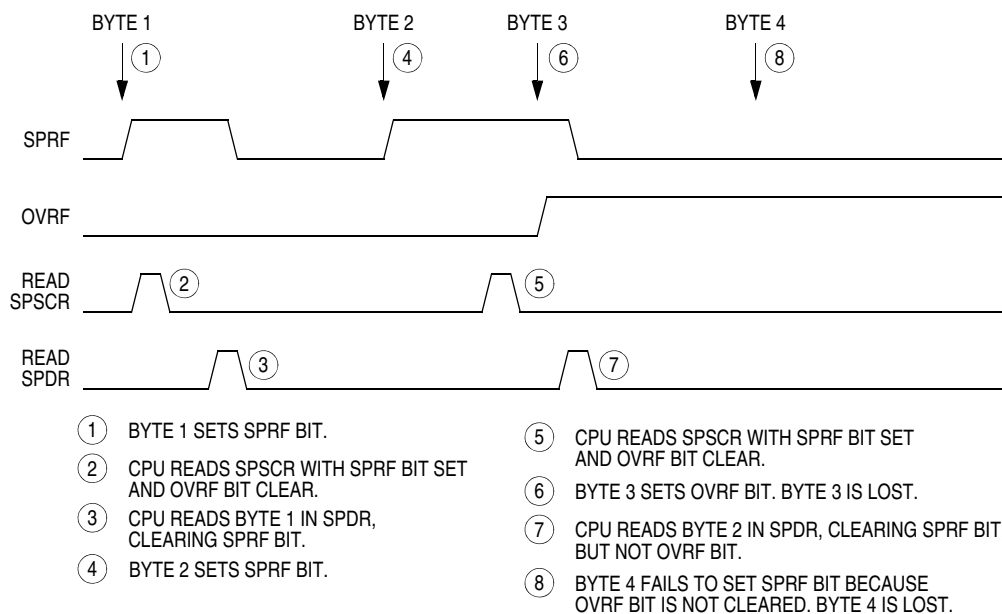
- Overflow (OVRF) — Failing to read the SPI data register before the next full byte enters the shift register sets the OVRF bit. The new byte does not transfer to the receive data register, and the unread byte still can be read. OVRF is in the SPI status and control register.
- Mode fault error (MODF) — The MODF bit indicates that the voltage on the slave select pin ( $\overline{SS}$ ) is inconsistent with the mode of the SPI. MODF is in the SPI status and control register.

### 20.7.1 Overflow Error

The overflow flag (OVRF) becomes set if the receive data register still has unread data from a previous transmission when the capture strobe of bit 1 of the next transmission occurs. The bit 1 capture strobe occurs in the middle of SPSCK cycle 7. (See [Figure 20-4](#) and [Figure 20-6](#).) If an overflow occurs, all data received after the overflow and before the OVRF bit is cleared does not transfer to the receive data register and does not set the SPI receiver full bit (SPRF). The unread data that transferred to the receive data register before the overflow occurred can still be read. Therefore, an overflow error always indicates the loss of data. Clear the overflow flag by reading the SPI status and control register and then reading the SPI data register.

OVRF generates a receiver/error CPU interrupt request if the error interrupt enable bit (ERRIE) is also set. The SPRF, MODF, and OVRF interrupts share the same CPU interrupt vector. See [Figure 20-11](#). It is not possible to enable MODF or OVRF individually to generate a receiver/error CPU interrupt request. However, leaving MODFEN low prevents MODF from being set.

If the CPU SPRF interrupt is enabled and the OVRF interrupt is not, watch for an overflow condition. [Figure 20-9](#) shows how it is possible to miss an overflow. The first part of [Figure 20-9](#) shows how it is possible to read the SPSCR and SPDR to clear the SPRF without problems. However, as illustrated by the second transmission example, the OVRF bit can be set in between the time that SPSCR and SPDR are read.



**Figure 20-9. Missed Read of Overflow Condition**

In this case, an overflow can be missed easily. Since no more SPRF interrupts can be generated until this OVRF is serviced, it is not obvious that bytes are being lost as more transmissions are completed. To prevent this, either enable the OVRF interrupt or do another read of the SPSCR following the read of the SPDR. This ensures that the OVRF was not set before the SPRF was cleared and that future transmissions can set the SPRF bit. Figure 20-10 illustrates this process. Generally, to avoid this second SPSCR read, enable the OVRF to the CPU by setting the ERRIE bit.

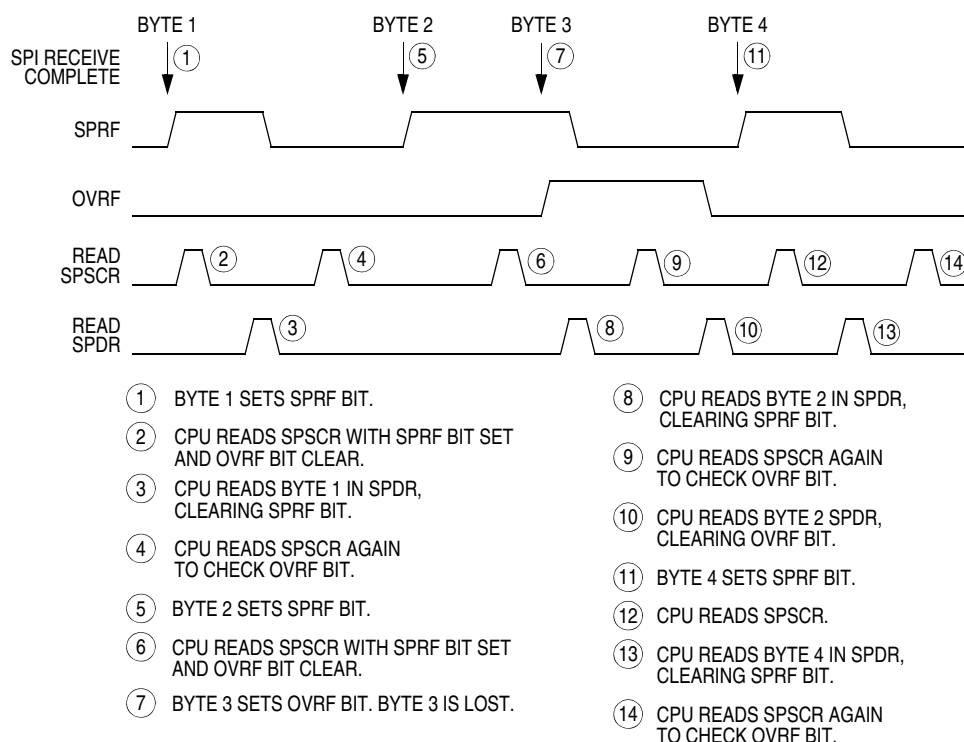


Figure 20-10. Clearing SPRF When OVRF Interrupt Is Not Enabled

## 20.7.2 Mode Fault Error

Setting the SPMSTR bit selects master mode and configures the SPSCCK and MOSI pins as outputs and the MISO pin as an input. Clearing SPMSTR selects slave mode and configures the SPSCCK and MOSI pins as inputs and the MISO pin as an output. The mode fault bit, MODF, becomes set any time the state of the slave select pin,  $\overline{SS}$ , is inconsistent with the mode selected by SPMSTR.

To prevent SPI pin contention and damage to the MCU, a mode fault error occurs if:

- The  $\overline{SS}$  pin of a slave SPI goes high during a transmission
- The  $\overline{SS}$  pin of a master SPI goes low at any time

For the MODF flag to be set, the mode fault error enable bit (MODFEN) must be set. Clearing the MODFEN bit does not clear the MODF flag but does prevent MODF from being set again after MODF is cleared.

MODF generates a receiver/error CPU interrupt request if the error interrupt enable bit (ERRIE) is also set. The SPRF, MODF, and OVRF interrupts share the same CPU interrupt vector. See Figure 20-11. It is not possible to enable MODF or OVRF individually to generate a receiver/error CPU interrupt request. However, leaving MODFEN low prevents MODF from being set.

## Serial Peripheral Interface (SPI)

In a master SPI with the mode fault enable bit (MODFEN) set, the mode fault flag (MODF) is set if  $\overline{SS}$  goes to logic 0. A mode fault in a master SPI causes the following events to occur:

- If ERRIE = 1, the SPI generates an SPI receiver/error CPU interrupt request.
- The SPE bit is cleared.
- The SPTE bit is set.
- The SPI state counter is cleared.
- The data direction register of the shared I/O port regains control of port drivers.

### NOTE

*To prevent bus contention with another master SPI after a mode fault error, clear all SPI bits of the data direction register of the shared I/O port before enabling the SPI.*

When configured as a slave (SPMSTR = 0), the MODF flag is set if  $\overline{SS}$  goes high during a transmission. When CPHA = 0, a transmission begins when  $\overline{SS}$  goes low and ends once the incoming SPSCCK goes back to its idle level following the shift of the eighth data bit. When CPHA = 1, the transmission begins when the SPSCCK leaves its idle level and  $\overline{SS}$  is already low. The transmission continues until the SPSCCK returns to its idle level following the shift of the last data bit. See [20.5 Transmission Formats](#).

### NOTE

*Setting the MODF flag does not clear the SPMSTR bit. The SPMSTR bit has no function when SPE = 0. Reading SPMSTR when MODF = 1 shows the difference between a MODF occurring when the SPI is a master and when it is a slave.*

*When CPHA = 0, a MODF occurs if a slave is selected ( $\overline{SS}$  is low) and later unselected ( $\overline{SS}$  is high) even if no SPSCCK is sent to that slave. This happens because  $\overline{SS}$  low indicates the start of the transmission (MISO driven out with the value of MSB) for CPHA = 0. When CPHA = 1, a slave can be selected and then later unselected with no transmission occurring. Therefore, MODF does not occur since a transmission was never begun.*

In a slave SPI (MSTR = 0), the MODF bit generates an SPI receiver/error CPU interrupt request if the ERRIE bit is set. The MODF bit does not clear the SPE bit or reset the SPI in any way. Software can abort the SPI transmission by clearing the SPE bit of the slave.

### NOTE

*A high on the  $\overline{SS}$  pin of a slave SPI puts the MISO pin in a high impedance state. Also, the slave SPI ignores all incoming SPSCCK clocks, even if it was already in the middle of a transmission.*

To clear the MODF flag, read the SPSCR with the MODF bit set and then write to the SPCR register. This entire clearing mechanism must occur with no MODF condition existing or else the flag is not cleared.



## 20.8 Interrupts

Four SPI status flags can be enabled to generate CPU interrupt requests.

**Table 20-2. SPI Interrupts**

Flag	Request
SPTIE Transmitter empty	SPI transmitter CPU interrupt request (SPTIE = 1, SPE = 1)
SPRIF Receiver full	SPI receiver CPU interrupt request (SPRIE = 1)
OVRF Overflow	SPI receiver/error interrupt request (ERRIE = 1)
MODF Mode fault	SPI receiver/error interrupt request (ERRIE = 1)

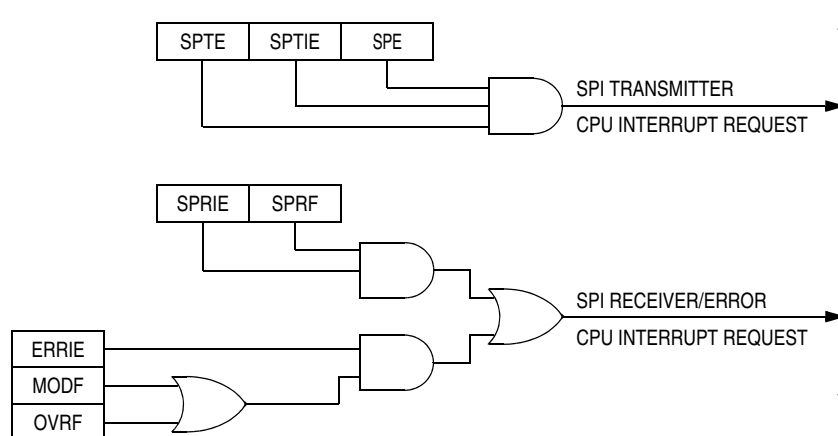
Reading the SPI status and control register with SPRF set and then reading the receive data register clears SPRF. The clearing mechanism for the SPTIE flag is always just a write to the transmit data register.

The SPI transmitter interrupt enable bit (SPTIE) enables the SPTIE flag to generate transmitter CPU interrupt requests, provided that the SPI is enabled (SPE = 1).

The SPI receiver interrupt enable bit (SPRIE) enables the SPRIF bit to generate receiver CPU interrupt requests, regardless of the state of the SPE bit. See [Figure 20-11](#).

The error interrupt enable bit (ERRIE) enables both the MODF and OVRF bits to generate a receiver/error CPU interrupt request.

The mode fault enable bit (MODFEN) can prevent the MODF flag from being set so that only the OVRF bit is enabled by the ERRIE bit to generate receiver/error CPU interrupt requests.



**Figure 20-11. SPI Interrupt Request Generation**

## Serial Peripheral Interface (SPI)

The following sources in the SPI status and control register can generate CPU interrupt requests:

- SPI receiver full bit (SPRF) — The SPRF bit becomes set every time a byte transfers from the shift register to the receive data register. If the SPI receiver interrupt enable bit, SPRIE, is also set, SPRF generates an SPI receiver/error CPU interrupt request.
- SPI transmitter empty (SPTE) — The SPTE bit becomes set every time a byte transfers from the transmit data register to the shift register. If the SPI transmit interrupt enable bit, SPTIE, is also set, SPTE generates an SPTE CPU interrupt request.

## 20.9 Resetting the SPI

Any system reset completely resets the SPI. Partial resets occur whenever the SPI enable bit (SPE) is 0. Whenever SPE is low, the following occurs:

- The SPTE flag is set.
- Any transmission currently in progress is aborted.
- The shift register is cleared.
- The SPI state counter is cleared, making it ready for a new complete transmission.
- All the SPI port logic is defaulted back to being general-purpose I/O.

These items are reset only by a system reset:

- All control bits in the SPCR register
- All control bits in the SPSCR register (MODFEN, ERRIE, SPR1, and SPR0)
- The status flags SPRF, OVRF, and MODF

By not resetting the control bits when SPE is low, the user can clear SPE between transmissions without having to set all control bits again when SPE is set back high for the next transmission.

By not resetting the SPRF, OVRF, and MODF flags, the user can still service these interrupts after the SPI has been disabled. The user can disable the SPI by writing 0 to the SPE bit. The SPI can also be disabled by a mode fault occurring in an SPI that was configured as a master with the MODFEN bit set.

## 20.10 Low-Power Modes

The WAIT and STOP instructions put the MCU in low power-consumption standby modes.

### 20.10.1 Wait Mode

The SPI module remains active after the execution of a WAIT instruction. In wait mode the SPI module registers are not accessible by the CPU. Any enabled CPU interrupt request from the SPI module can bring the MCU out of wait mode.

If SPI module functions are not required during wait mode, reduce power consumption by disabling the SPI module before executing the WAIT instruction.

To exit wait mode when an overflow condition occurs, enable the OVRF bit to generate CPU interrupt requests by setting the error interrupt enable bit (ERRIE). See [20.8 Interrupts](#).

### 20.10.2 Stop Mode

The SPI module is inactive after the execution of a STOP instruction. The STOP instruction does not affect register conditions. SPI operation resumes after an external interrupt. If stop mode is exited by reset, any transfer in progress is aborted, and the SPI is reset.

## 20.11 SPI During Break Interrupts

The system integration module (SIM) controls whether status bits in other modules can be cleared during the break state. The BCFE bit in the SIM break flag control register (SBFCR) enables software to clear status bits during the break state. See [Chapter 19 System Integration Module \(SIM\)](#).

To allow software to clear status bits during a break interrupt, write a 1 to the BCFE bit. If a status bit is cleared during the break state, it remains cleared when the MCU exits the break state.

To protect status bits during the break state, write a 0 to the BCFE bit. With BCFE at 0 (its default state), software can read and write I/O registers during the break state without affecting status bits. Some status bits have a 2-step read/write clearing procedure. If software does the first step on such a bit before the break, the bit cannot change during the break state as long as BCFE is at 0. After the break, doing the second step clears the status bit.

Since the SPTE bit cannot be cleared during a break with the BCFE bit cleared, a write to the transmit data register in break mode does not initiate a transmission nor is this data transferred into the shift register. Therefore, a write to the SPDR in break mode with the BCFE bit cleared has no effect.

## 20.12 I/O Signals

The SPI module has four I/O pins and shares four of them with a parallel I/O port. They are:

- MISO — Data received
- MOSI — Data transmitted
- SPCK — Serial clock
- $\overline{SS}$  — Slave select

The SPI has limited inter-integrated circuit (I<sup>2</sup>C) capability (requiring software support) as a master in a single-master environment. To communicate with I<sup>2</sup>C peripherals, MOSI becomes an open-drain output when the SPWOM bit in the SPI control register is set. In I<sup>2</sup>C communication, the MOSI and MISO pins are connected to a bidirectional pin from the I<sup>2</sup>C peripheral and through a pullup resistor to V<sub>DD</sub>.

### 20.12.1 MISO (Master In/Slave Out)

MISO is one of the two SPI module pins that transmits serial data. In full duplex operation, the MISO pin of the master SPI module is connected to the MISO pin of the slave SPI module. The master SPI simultaneously receives data on its MISO pin and transmits data from its MOSI pin.

Slave output data on the MISO pin is enabled only when the SPI is configured as a slave. The SPI is configured as a slave when its SPMSTR bit is 0 and its  $\overline{SS}$  pin is low. To support a multiple-slave system, a high on the  $\overline{SS}$  pin puts the MISO pin in a high-impedance state.

When enabled, the SPI controls data direction of the MISO pin regardless of the state of the data direction register of the shared I/O port.

### 20.12.2 MOSI (Master Out/Slave In)

MOSI is one of the two SPI module pins that transmits serial data. In full-duplex operation, the MOSI pin of the master SPI module is connected to the MOSI pin of the slave SPI module. The master SPI simultaneously transmits data from its MOSI pin and receives data on its MISO pin.

When enabled, the SPI controls data direction of the MOSI pin regardless of the state of the data direction register of the shared I/O port.

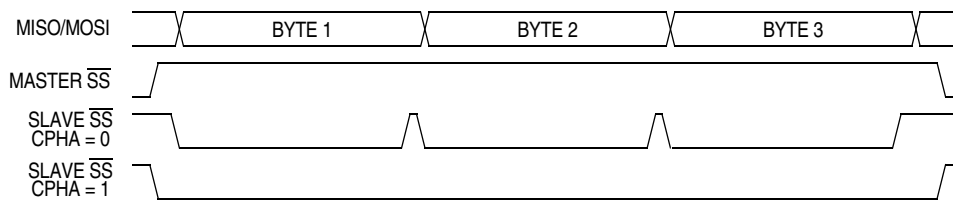
### 20.12.3 SPSCCK (Serial Clock)

The serial clock synchronizes data transmission between master and slave devices. In a master MCU, the SPSCCK pin is the clock output. In a slave MCU, the SPSCCK pin is the clock input. In full-duplex operation, the master and slave MCUs exchange a byte of data in eight serial clock cycles.

When enabled, the SPI controls data direction of the SPSCCK pin regardless of the state of the data direction register of the shared I/O port.

### 20.12.4 $\overline{SS}$ (Slave Select)

The  $\overline{SS}$  pin has various functions depending on the current state of the SPI. For an SPI configured as a slave, the  $\overline{SS}$  is used to select a slave. For  $CPHA = 0$ , the  $\overline{SS}$  is used to define the start of a transmission. See [20.5 Transmission Formats](#). Since it is used to indicate the start of a transmission, the  $\overline{SS}$  must be toggled high and low between each byte transmitted for the  $CPHA = 0$  format. However, it can remain low between transmissions for the  $CPHA = 1$  format. See [Figure 20-12](#).



**Figure 20-12. CPHA/ $\overline{SS}$  Timing**

When an SPI is configured as a slave, the  $\overline{SS}$  pin is always configured as an input. It cannot be used as a general-purpose I/O regardless of the state of the MODFEN control bit. However, the MODFEN bit can still prevent the state of the  $\overline{SS}$  from creating a MODF error. See [20.13.2 SPI Status and Control Register](#).

#### NOTE

*A high voltage on the  $\overline{SS}$  pin of a slave SPI puts the MISO pin in a high-impedance state. The slave SPI ignores all incoming SPSCCK clocks, even if it was already in the middle of a transmission.*

When an SPI is configured as a master, the  $\overline{SS}$  input can be used in conjunction with the MODF flag to prevent multiple masters from driving MOSI and SPSCCK. See [20.7.2 Mode Fault Error](#). For the state of the  $\overline{SS}$  pin to set the MODF flag, the MODFEN bit in the SPSCCK register must be set. If the MODFEN bit is low for an SPI master, the  $\overline{SS}$  pin can be used as a general-purpose I/O under the control of the data direction register of the shared I/O port. With MODFEN high, it is an input-only pin to the SPI regardless of the state of the data direction register of the shared I/O port.

The CPU can always read the state of the  $\overline{SS}$  pin by configuring the appropriate pin as an input and reading the port data register. See [Table 20-3](#).

**Table 20-3. SPI Configuration**

SPE	SPMSTR	MODFEN	SPI Configuration	State of $\overline{SS}$ Logic
0	X <sup>(1)</sup>	X	Not enabled	General-purpose I/O; $\overline{SS}$ ignored by SPI
1	0	X	Slave	Input-only to SPI
1	1	0	Master without MODF	General-purpose I/O; $\overline{SS}$ ignored by SPI
1	1	1	Master with MODF	Input-only to SPI

Note 1. X = Don't care

## 20.13 I/O Registers

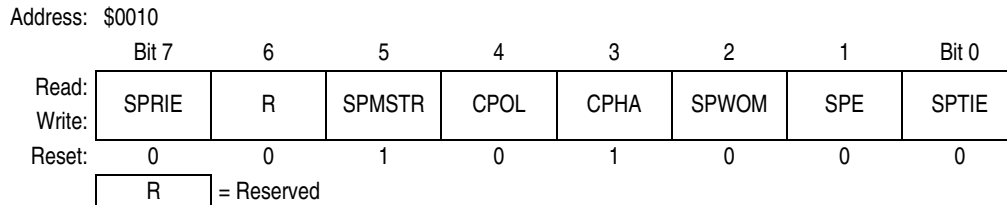
Three registers control and monitor SPI operation:

- SPI control register (SPCR)
- SPI status and control register (SPSCR)
- SPI data register (SPDR)

### 20.13.1 SPI Control Register

The SPI control register:

- Enables SPI module interrupt requests
- Configures the SPI module as master or slave
- Selects serial clock polarity and phase
- Configures the SPSCCK, MOSI, and MISO pins as open-drain outputs
- Enables the SPI module



**Figure 20-13. SPI Control Register (SPCR)**

#### SPRIE — SPI Receiver Interrupt Enable Bit

This read/write bit enables CPU interrupt requests generated by the SPRF bit. The SPRF bit is set when a byte transfers from the shift register to the receive data register. Reset clears the SPRIE bit.

- 1 = SPRF CPU interrupt requests enabled
- 0 = SPRF CPU interrupt requests disabled

#### SPMSTR — SPI Master Bit

This read/write bit selects master mode operation or slave mode operation. Reset sets the SPMSTR bit.

- 1 = Master mode
- 0 = Slave mode

#### CPOL — Clock Polarity Bit

This read/write bit determines the logic state of the SPSCCK pin between transmissions. (See [Figure 20-4](#) and [Figure 20-6](#).) To transmit data between SPI modules, the SPI modules must have identical CPOL values. Reset clears the CPOL bit.

#### CPHA — Clock Phase Bit

This read/write bit controls the timing relationship between the serial clock and SPI data. (See [Figure 20-4](#) and [Figure 20-6](#).) To transmit data between SPI modules, the SPI modules must have identical CPHA values. When CPHA = 0, the  $\overline{SS}$  pin of the slave SPI module must be set to logic 1 between bytes. See [Figure 20-12](#). Reset sets the CPHA bit.

## Serial Peripheral Interface (SPI)

### SPWOM — SPI Wired-OR Mode Bit

This read/write bit disables the pullup devices on pins SPSCCK, MOSI, and MISO so that those pins become open-drain outputs.

- 1 = Wired-OR SPSCCK, MOSI, and MISO pins
- 0 = Normal push-pull SPSCCK, MOSI, and MISO pins

### SPE — SPI Enable

This read/write bit enables the SPI module. Clearing SPE causes a partial reset of the SPI. See [20.9 Resetting the SPI](#). Reset clears the SPE bit.

- 1 = SPI module enabled
- 0 = SPI module disabled

### SPTIE— SPI Transmit Interrupt Enable

This read/write bit enables CPU interrupt requests generated by the SPTE bit. SPTE is set when a byte transfers from the transmit data register to the shift register. Reset clears the SPTIE bit.

- 1 = SPTE CPU interrupt requests enabled
- 0 = SPTE CPU interrupt requests disabled

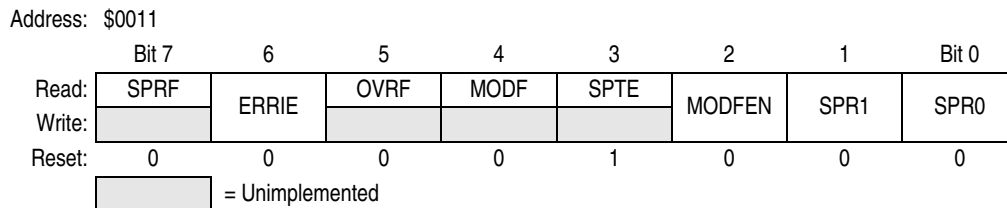
## 20.13.2 SPI Status and Control Register

The SPI status and control register contains flags to signal these conditions:

- Receive data register full
- Failure to clear SPRF bit before next byte is received (overflow error)
- Inconsistent logic level on  $\overline{SS}$  pin (mode fault error)
- Transmit data register empty

The SPI status and control register also contains bits that perform these functions:

- Enable error interrupts
- Enable mode fault error detection
- Select master SPI baud rate



**Figure 20-14. SPI Status and Control Register (SPSCR)**

### SPRF — SPI Receiver Full Bit

This clearable, read-only flag is set each time a byte transfers from the shift register to the receive data register. SPRF generates a CPU interrupt request if the SPRIE bit in the SPI control register is set also. During an SPRF CPU interrupt, the CPU clears SPRF by reading the SPI status and control register with SPRF set and then reading the SPI data register. Reset clears the SPRF bit.

- 1 = Receive data register full
- 0 = Receive data register not full

### ERRIE — Error Interrupt Enable Bit

This read/write bit enables the MODF and OVRF bits to generate CPU interrupt requests. Reset clears the ERRIE bit.

- 1 = MODF and OVRF can generate CPU interrupt requests
- 0 = MODF and OVRF cannot generate CPU interrupt requests

**OVRF — Overflow Bit**

This clearable, read-only flag is set if software does not read the byte in the receive data register before the next full byte enters the shift register. In an overflow condition, the byte already in the receive data register is unaffected, and the byte that shifted in last is lost. Clear the OVRF bit by reading the SPI status and control register with OVRF set and then reading the receive data register. Reset clears the OVRF bit.

- 1 = Overflow
- 0 = No overflow

**MODF — Mode Fault Bit**

This clearable, read-only flag is set in a slave SPI if the  $\overline{SS}$  pin goes high during a transmission with the MODFEN bit set. In a master SPI, the MODF flag is set if the  $\overline{SS}$  pin goes low at any time with the MODFEN bit set. Clear the MODF bit by reading the SPI status and control register (SPSCR) with MODF set and then writing to the SPI data register (SPDR). Reset clears the MODF bit.

- 1 =  $\overline{SS}$  pin at inappropriate logic level
- 0 =  $\overline{SS}$  pin at appropriate logic level

**SPTIE — SPI Transmitter Empty Bit**

This clearable, read-only flag is set each time the transmit data register transfers a byte into the shift register. SPTIE generates an SPTIE CPU interrupt request if the SPTIE bit in the SPI control register is set also.

**NOTE**

*Do not write to the SPI data register unless the SPTIE bit is high.*

During an SPTIE CPU interrupt, the CPU clears the SPTIE bit by writing to the transmit data register. Reset sets the SPTIE bit.

- 1 = Transmit data register empty
- 0 = Transmit data register not empty

**MODFEN — Mode Fault Enable Bit**

This read/write bit, when set to 1, allows the MODF flag to be set. If the MODF flag is set, clearing the MODFEN does not clear the MODF flag. If the SPI is enabled as a master and the MODFEN bit is 0, then the  $\overline{SS}$  pin is available as a general-purpose I/O.

If the MODFEN bit is set, then this pin is not available as a general-purpose I/O. When the SPI is enabled as a slave, the  $\overline{SS}$  pin is not available as a general-purpose I/O regardless of the value of MODFEN. See [20.12.4 SS \(Slave Select\)](#).

If the MODFEN bit is 0, the level of the  $\overline{SS}$  pin does not affect the operation of an enabled SPI configured as a master. For an enabled SPI configured as a slave, having MODFEN low only prevents the MODF flag from being set. It does not affect any other part of SPI operation. See [20.7.2 Mode Fault Error](#).

**SPR1 and SPR0 — SPI Baud Rate Select Bits**

In master mode, these read/write bits select one of four baud rates as shown in [Table 20-4](#). SPR1 and SPR0 have no effect in slave mode. Reset clears SPR1 and SPR0.

**Table 20-4. SPI Master Baud Rate Selection**

SPR1 and SPR0	Baud Rate Divisor (BD)
00	2
01	8
10	32
11	128

Use this formula to calculate the SPI baud rate:

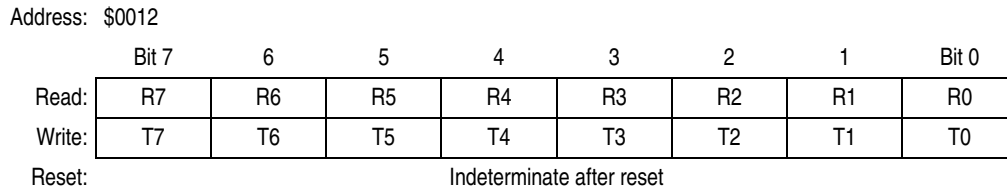
$$\text{Baud rate} = \frac{\text{BUSCLK}}{\text{BD}}$$

where:

BD = baud rate divisor

**20.13.3 SPI Data Register**

The SPI data register consists of the read-only receive data register and the write-only transmit data register. Writing to the SPI data register writes data into the transmit data register. Reading the SPI data register reads data from the receive data register. The transmit data and receive data registers are separate registers that can contain different values. See [Figure 20-2](#).



**Figure 20-15. SPI Data Register (SPDR)**

**R7–R0/T7–T0 — Receive/Transmit Data Bits**

**NOTE**

*Do not use read-modify-write instructions on the SPI data register since the register read is not the same as the register written.*



# Chapter 21

## Timebase Module (TBM)

### 21.1 Introduction

This section describes the timebase module (TBM). The TBM will generate periodic interrupts at user selectable rates using a counter clocked by the external crystal clock. This TBM version uses 15 divider stages, eight of which are user selectable.

For further information regarding timers on M68HC08 family devices, please consult the HC08 Timer Reference Manual, TIM08RM/AD.

### 21.2 Features

Features of the TBM module include:

- Software programmable 1 Hz, 4 Hz, 16 Hz, 256 Hz, 512 Hz, 1024 Hz, 2048 Hz, and 4096 Hz periodic interrupt using external 32.768 kHz crystal
- User selectable oscillator clock source enable during stop mode to allow periodic wakeup from stop

### 21.3 Functional Description

**NOTE**

*This module is designed for a 32.768 kHz oscillator.*

This module can generate a periodic interrupt by dividing the crystal frequency, CGMXCLK. The counter is initialized to all 0s when TBON bit is cleared. The counter, shown in [Figure 21-1](#), starts counting when the TBON bit is set. When the counter overflows at the tap selected by TBR2:TBR0, the TBIF bit gets set. If the TBIE bit is set, an interrupt request is sent to the CPU. The TBIF flag is cleared by writing a 1 to the TACK bit. The first time the TBIF flag is set after enabling the timebase module, the interrupt is generated at approximately half of the overflow period. Subsequent events occur at the exact period.

The timebase module may remain active after execution of the STOP instruction if the crystal oscillator has been enabled to operate during stop mode through the OSCSTOPENB bit in the configuration register. The timebase module can be used in this mode to generate periodic wakeup from stop mode.

### 21.4 Interrupts

The timebase module can periodically interrupt the CPU with a rate defined by TBR2:TBR0. When the timebase counter chain rolls over, the TBIF flag is set. If the TBIE bit is set, enabling the timebase interrupt, the counter chain overflow will generate a CPU interrupt request.

**NOTE**

*Interrupts must be acknowledged by writing a 1 to the TACK bit.*



If the timebase functions are not required during stop mode, reduce the power consumption by stopping the timebase before enabling the STOP instruction.

## 21.6 Timebase Register Description

The timebase has one register, the TBCR, which is used to enable the timebase interrupts and set the rate.



**Figure 21-2. Timebase Control Register (TBCR)**

### TBIF — Timebase Interrupt Flag

This read-only flag bit is set when the timebase counter has rolled over.

1 = Timebase interrupt pending

0 = Timebase interrupt not pending

### TBR2:TBR0 — Timebase Rate Selection

These read/write bits are used to select the rate of timebase interrupts as shown in [Table 21-1](#).

**Table 21-1. Timebase Rate Selection for OSC1 = 32.768 kHz**

TBR2	TBR1	TBR0	Divider	Timebase Interrupt Rate	
				Hz	ms
0	0	0	32,768	1	1000
0	0	1	8192	4	250
0	1	0	2048	16	62.5
0	1	1	128	256	~ 3.9
1	0	0	64	512	~2
1	0	1	32	1024	~1
1	1	0	16	2048	~0.5
1	1	1	8	4096	~0.24

### NOTE

*Do not change TBR2–TBR0 bits while the timebase is enabled (TBON = 1).*

### TACK— Timebase ACKnowledge

The TACK bit is a write-only bit and always reads as 0. Writing a 1 to this bit clears TBIF, the timebase interrupt flag bit. Writing a 0 to this bit has no effect.

1 = Clear timebase interrupt flag

0 = No effect

## Timebase Module (TBM)

### **TBIE — Timebase Interrupt Enabled**

This read/write bit enables the timebase interrupt when the TBIF bit becomes set. Reset clears the TBIE bit.

1 = Timebase interrupt enabled

0 = Timebase interrupt disabled

### **TBON — Timebase Enabled**

This read/write bit enables the timebase. Timebase may be turned off to reduce power consumption when its function is not necessary. The counter can be initialized by clearing and then setting this bit. Reset clears the TBON bit.

1 = Timebase enabled

0 = Timebase disabled and the counter initialized to 0s

# Chapter 22

## Timer Interface Module (TIM)

### 22.1 Introduction

This section describes the timer interface (TIM) module. The TIM on this part is a 2-channel and a1-channel timer that provides a timing reference with input capture, output compare, and pulse-width-modulation functions. [Figure 22-1](#) is a block diagram of the TIM. This particular MCU has two timer interface modules which are denoted as TIM1 and TIM2.

For further information regarding timers on M68HC08 family devices, please consult the HC08 Timer Reference Manual, TIM08RM/AD.

### 22.2 Features

Features of the TIM include:

- Three input capture/output compare channels:
  - Rising-edge, falling-edge, or any-edge input capture trigger
  - Set, clear, or toggle output compare action
- Buffered and unbuffered pulse-width-modulation (PWM) signal generation
- Programmable TIM clock input with 7-frequency internal bus clock prescaler selection
- Free-running or modulo up-count operation
- Toggle any channel pin on overflow
- TIM counter stop and reset bits

### 22.3 Pin Name Conventions

The text that follows describes both timers, TIM1 and TIM2. The TIM input/output (I/O) pin names are T[1,2]CH0 (timer 1 channel 0, timer 2 channel 0) and T[1]CH1 (timer channel 1), where “1” is used to indicate TIM1 and “2” is used to indicate TIM2. The two TIMs share three I/O pins with three port D I/O port pins. The full names of the TIM I/O pins are listed in [Table 22-1](#). The generic pin names appear in the text that follows.

**Table 22-1. Pin Name Conventions**

TIM Generic Pin Names:		T[1,2]CH0	T[1,2]CH1
Full TIM Pin Names:	TIM1	PTD4/ATD12/T1CH0	PTD5/T1CH1
	TIM2	PTD6/ATD14/T2CH0	—

### NOTE

References to either timer 1 or timer 2 may be made in the following text by omitting the timer number. For example, TCH0 may refer generically to T1CH0 and T2CH0, and TCH1 will refer to T1CH1.

### NOTE

The Timer Interface Module in MC68HC908GR8 is constructed by TIM1 which contains channel 0 and 1, and TIM2 which contains channel 0 only.

## 22.4 Functional Description

Figure 22-1 shows the structure of the TIM. The central component of the TIM is the 16-bit TIM counter that can operate as a free-running counter or a modulo up-counter. The TIM counter provides the timing reference for the input capture and output compare functions. The TIM counter modulo registers, TMODH:TMODL, control the modulo value of the TIM counter. Software can read the TIM counter value at any time without affecting the counting sequence.

The TIM channels (per timer) are programmable independently as input capture or output compare channels. If a channel is configured as input capture, then an internal pullup device may be enabled for that channel. See [Port D Input Pullup Enable Register](#).

In Figure 22-1, channel1 will only be available in TIM1 while channel 0 will be available in both TIM1 and TIM2.

Figure 22-2 summarizes the timer registers.

### 22.4.1 TIM Counter Prescaler

The TIM clock source can be one of the seven prescaler outputs. The prescaler generates seven clock rates from the internal bus clock. The prescaler select bits, PS[2:0], in the TIM status and control register select the TIM clock source.

### 22.4.2 Input Capture

With the input capture function, the TIM can capture the time at which an external event occurs. When an active edge occurs on the pin of an input capture channel, the TIM latches the contents of the TIM counter into the TIM channel registers, TCHxH:TCHxL. The polarity of the active edge is programmable. Input captures can generate TIM CPU interrupt requests.

### 22.4.3 Output Compare

With the output compare function, the TIM can generate a periodic pulse with a programmable polarity, duration, and frequency. When the counter reaches the value in the registers of an output compare channel, the TIM can set, clear, or toggle the channel pin. Output compares can generate TIM CPU interrupt requests.

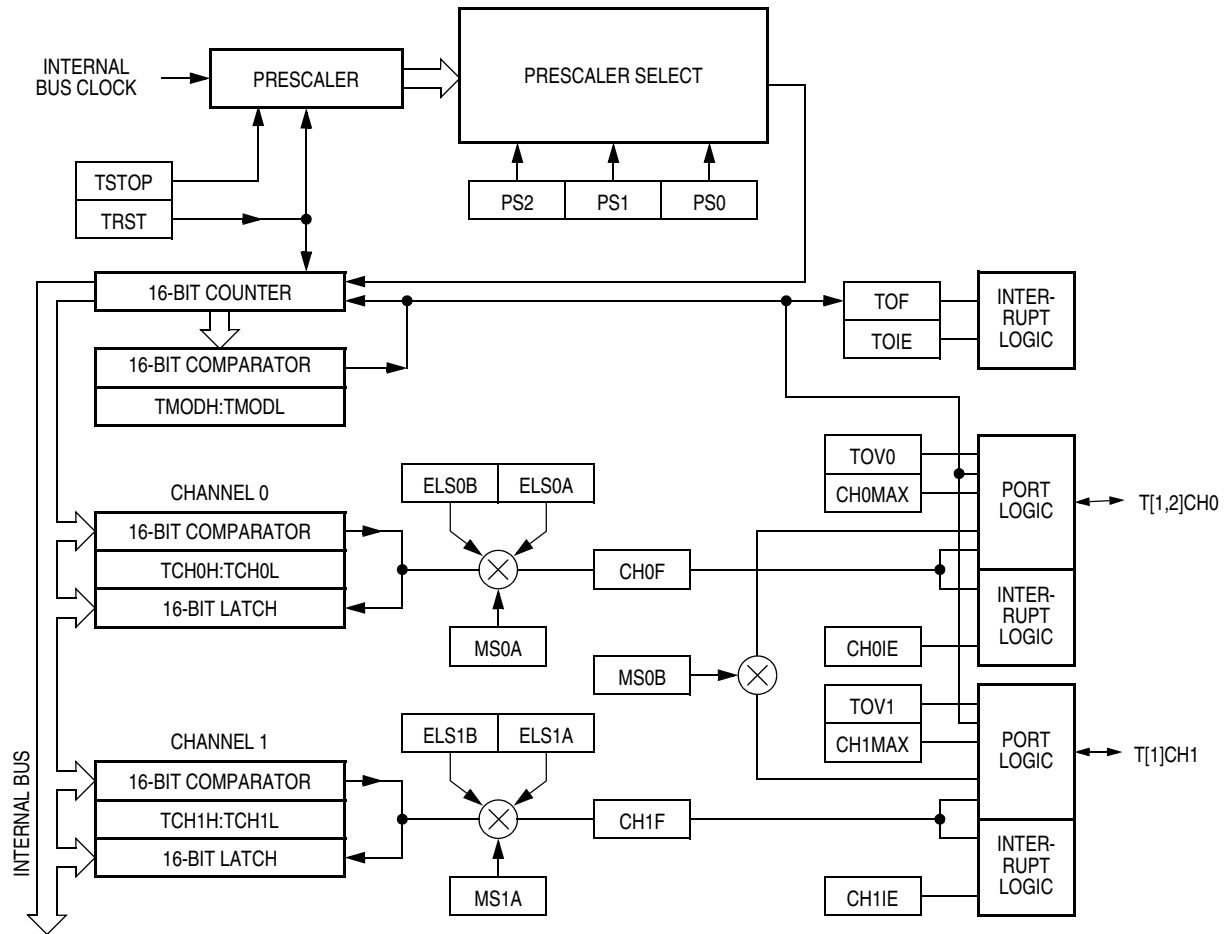


Figure 22-1. TIM Block Diagram

**NOTE**

References to either timer 1 or timer 2 may be made in the following text by omitting the timer number. For example, TSC may generically refer to both T1SC and T2SC.

## Timer Interface Module (TIM)

Addr.	Register Name	Bit 7	6	5	4	3	2	1	Bit 0	
\$0020	Timer 1 Status and Control Register (T1SC)	Read:	TOF	TOIE	TSTOP	0	0	PS2	PS1	PS0
		Write:	0			TRST				
		Reset:	0	0	1	0	0	0	0	0
\$0021	Timer 1 Counter Register High (T1CNTH)	Read:	Bit 15	14	13	12	11	10	9	Bit 8
		Write:								
		Reset:	0	0	0	0	0	0	0	0
\$0022	Timer 1 Counter Register Low (T1CNTL)	Read:	Bit 7	6	5	4	3	2	1	Bit 0
		Write:								
		Reset:	0	0	0	0	0	0	0	0
\$0023	Timer 1 Counter Modulo Register High (T1MODH)	Read:	Bit 15	14	13	12	11	10	9	Bit 8
		Write:								
		Reset:	1	1	1	1	1	1	1	1
\$0024	Timer 1 Counter Modulo Register Low (T1MODL)	Read:	Bit 7	6	5	4	3	2	1	Bit 0
		Write:								
		Reset:	1	1	1	1	1	1	1	1
\$0025	Timer 1 Channel 0 Status and Control Register (T1SC0)	Read:	CH0F	CH0IE	MS0B	MS0A	ELS0B	ELS0A	TOV0	CH0MAX
		Write:	0							
		Reset:	0	0	0	0	0	0	0	0
\$0026	Timer 1 Channel 0 Register High (T1CH0H)	Read:	Bit 15	14	13	12	11	10	9	Bit 8
		Write:								
		Reset:	Indeterminate after reset							
\$0027	Timer 1 Channel 0 Register Low (T1CH0L)	Read:	Bit 7	6	5	4	3	2	1	Bit 0
		Write:								
		Reset:	Indeterminate after reset							
\$0028	Timer 1 Channel 1 Status and Control Register (T1SC1)	Read:	CH1F	CH1IE	0	MS1A	ELS1B	ELS1A	TOV1	CH1MAX
		Write:	0							
		Reset:	0	0	0	0	0	0	0	0
\$0029	Timer 1 Channel 1 Register High (T1CH1H)	Read:	Bit 15	14	13	12	11	10	9	Bit 8
		Write:								
		Reset:	Indeterminate after reset							
\$002A	Timer 1 Channel 1 Register Low (T1CH1L)	Read:	Bit 7	6	5	4	3	2	1	Bit 0
		Write:								
		Reset:	Indeterminate after reset							
\$002B	Timer 2 Status and Control Register (T2SC)	Read:	TOF	TOIE	TSTOP	0	0	PS2	PS1	PS0
		Write:	0			TRST				
		Reset:	0	0	1	0	0	0	0	0

= Unimplemented

**Figure 22-2. TIM I/O Register Summary (Sheet 1 of 2)**



Addr.	Register Name	Bit 7	6	5	4	3	2	1	Bit 0	
\$002C	Timer 2 Counter Register High (T2CNTH)	Read:	Bit 15	14	13	12	11	10	9	Bit 8
		Write:								
		Reset:	0	0	0	0	0	0	0	0
\$002D	Timer 2 Counter Register Low (T2CNTL)	Read:	Bit 7	6	5	4	3	2	1	Bit 0
		Write:								
		Reset:	0	0	0	0	0	0	0	0
\$002E	Timer 2 Counter Modulo Register High (T2MODH)	Read:	Bit 15	14	13	12	11	10	9	Bit 8
		Write:								
		Reset:	1	1	1	1	1	1	1	1
\$002F	Timer 2 Counter Modulo Register Low (T2MODL)	Read:	Bit 7	6	5	4	3	2	1	Bit 0
		Write:								
		Reset:	1	1	1	1	1	1	1	1
\$0030	Timer 2 Channel 0 Status and Control Register (T2SC0)	Read:	CH0F	CH0IE	MS0B	MS0A	ELS0B	ELS0A	TOV0	CH0MAX
		Write:	0							
		Reset:	0	0	0	0	0	0	0	0
\$0031	Timer 2 Channel 0 Register High (T2CH0H)	Read:	Bit 15	14	13	12	11	10	9	Bit 8
		Write:								
		Reset:	Indeterminate after reset							
\$0032	Timer 2 Channel 0 Register Low (T2CH0L)	Read:	Bit 7	6	5	4	3	2	1	Bit 0
		Write:								
		Reset:	Indeterminate after reset							
\$0033	Unimplemented	Read:								
		Write:								
		Reset:	0	0	0	0	0	0	0	0
\$0034	Unimplemented	Read:								
		Write:								
		Reset:	Indeterminate after reset							
\$0035	Unimplemented	Read:								
		Write:								
		Reset:	Indeterminate after reset							

= Unimplemented

Figure 22-2. TIM I/O Register Summary (Sheet 2 of 2)

### 22.4.3.1 Unbuffered Output Compare

Any output compare channel can generate unbuffered output compare pulses as described in Output Compare. The pulses are unbuffered because changing the output compare value requires writing the new value over the old value currently in the TIM channel registers.

An unsynchronized write to the TIM channel registers to change an output compare value could cause incorrect operation for up to two counter overflow periods. For example, writing a new value before the counter reaches the old value but after the counter reaches the new value prevents any compare during that counter overflow period. Also, using a TIM overflow interrupt routine to write a new, smaller output compare value may cause the compare to be missed. The TIM may pass the new value before it is written.

Use the following methods to synchronize unbuffered changes in the output compare value on channel x:

- When changing to a smaller value, enable channel x output compare interrupts and write the new value in the output compare interrupt routine. The output compare interrupt occurs at the end of the current output compare pulse. The interrupt routine has until the end of the counter overflow period to write the new value.
- When changing to a larger output compare value, enable TIM overflow interrupts and write the new value in the TIM overflow interrupt routine. The TIM overflow interrupt occurs at the end of the current counter overflow period. Writing a larger value in an output compare interrupt routine (at the end of the current pulse) could cause two output compares to occur in the same counter overflow period.

### 22.4.3.2 Buffered Output Compare

Channels 0 and 1 can be linked to form a buffered output compare channel whose output appears on the TCH0 pin. The TIM channel registers of the linked pair alternately control the output.

Setting the MS0B bit in TIM channel 0 status and control register (TSC0) links channel 0 and channel 1. The output compare value in the TIM channel 0 registers initially controls the output on the TCH0 pin. Writing to the TIM channel 1 registers enables the TIM channel 1 registers to synchronously control the output after the TIM overflows. At each subsequent overflow, the TIM channel registers (0 or 1) that control the output are the ones written to last. TSC0 controls and monitors the buffered output compare function, and TIM channel 1 status and control register (TSC1) is unused. While the MS0B bit is set, the channel 1 pin, TCH1, is available as a general-purpose I/O pin.

#### NOTE

*In buffered output compare operation, do not write new output compare values to the currently active channel registers. User software should track the currently active channel to prevent writing a new value to the active channel. Writing to the active channel registers is the same as generating unbuffered output compares.*

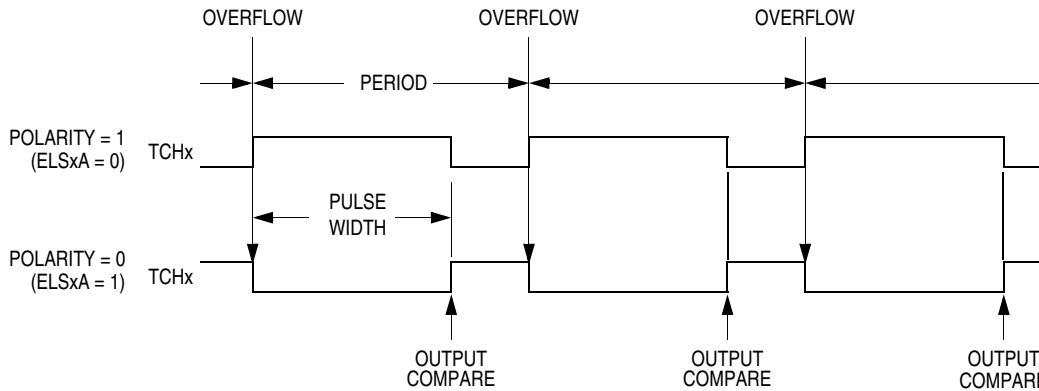
### 22.4.4 Pulse Width Modulation (PWM)

By using the toggle-on-overflow feature with an output compare channel, the TIM can generate a PWM signal. The value in the TIM counter modulo registers determines the period of the PWM signal. The channel pin toggles when the counter reaches the value in the TIM counter modulo registers. The time between overflows is the period of the PWM signal.

As [Figure 22-3](#) shows, the output compare value in the TIM channel registers determines the pulse width of the PWM signal. The time between overflow and output compare is the pulse width. Program the TIM

to clear the channel pin on output compare if the state of the PWM pulse is 1. Program the TIM to set the pin if the state of the PWM pulse is 0.

The value in the TIM counter modulo registers and the selected prescaler output determines the frequency of the PWM output. The frequency of an 8-bit PWM signal is variable in 256 increments. Writing \$00FF (255) to the TIM counter modulo registers produces a PWM period of 256 times the internal bus clock period if the prescaler select value is \$000. See TIM Status and Control Register.



**Figure 22-3. PWM Period and Pulse Width**

The value in the TIM channel registers determines the pulse width of the PWM output. The pulse width of an 8-bit PWM signal is variable in 256 increments. Writing \$0080 (128) to the TIM channel registers produces a duty cycle of 128/256 or 50%.

#### 22.4.4.1 Unbuffered PWM Signal Generation

Any output compare channel can generate unbuffered PWM pulses as described in Pulse Width Modulation (PWM). The pulses are unbuffered because changing the pulse width requires writing the new pulse width value over the old value currently in the TIM channel registers.

An unsynchronized write to the TIM channel registers to change a pulse width value could cause incorrect operation for up to two PWM periods. For example, writing a new value before the counter reaches the old value but after the counter reaches the new value prevents any compare during that PWM period. Also, using a TIM overflow interrupt routine to write a new, smaller pulse width value may cause the compare to be missed. The TIM may pass the new value before it is written.

Use the following methods to synchronize unbuffered changes in the PWM pulse width on channel x:

- When changing to a shorter pulse width, enable channel x output compare interrupts and write the new value in the output compare interrupt routine. The output compare interrupt occurs at the end of the current pulse. The interrupt routine has until the end of the PWM period to write the new value.
- When changing to a longer pulse width, enable TIM overflow interrupts and write the new value in the TIM overflow interrupt routine. The TIM overflow interrupt occurs at the end of the current PWM period. Writing a larger value in an output compare interrupt routine (at the end of the current pulse) could cause two output compares to occur in the same PWM period.

#### **NOTE**

*In PWM signal generation, do not program the PWM channel to toggle on output compare. Toggling on output compare prevents reliable 0% duty*

*cycle generation and removes the ability of the channel to self-correct in the event of software error or noise. Toggling on output compare also can cause incorrect PWM signal generation when changing the PWM pulse width to a new, much larger value.*

### 22.4.4.2 Buffered PWM Signal Generation

Channels 0 and 1 can be linked to form a buffered PWM channel whose output appears on the TCH0 pin. The TIM channel registers of the linked pair alternately control the pulse width of the output.

Setting the MS0B bit in TIM channel 0 status and control register (TSC0) links channel 0 and channel 1. The TIM channel 0 registers initially control the pulse width on the TCH0 pin. Writing to the TIM channel 1 registers enables the TIM channel 1 registers to synchronously control the pulse width at the beginning of the next PWM period. At each subsequent overflow, the TIM channel registers (0 or 1) that control the pulse width are the ones written to last. TSC0 controls and monitors the buffered PWM function, and TIM channel 1 status and control register (TSC1) is unused. While the MS0B bit is set, the channel 1 pin, TCH1, is available as a general-purpose I/O pin.

#### NOTE

*In buffered PWM signal generation, do not write new pulse width values to the currently active channel registers. User software should track the currently active channel to prevent writing a new value to the active channel. Writing to the active channel registers is the same as generating unbuffered PWM signals.*

### 22.4.4.3 PWM Initialization

To ensure correct operation when generating unbuffered or buffered PWM signals, use the following initialization procedure:

1. In the TIM status and control register (TSC):
  - a. Stop the TIM counter by setting the TIM stop bit, TSTOP.
  - b. Reset the TIM counter and prescaler by setting the TIM reset bit, TRST.
2. In the TIM counter modulo registers (TMODH:TMODL), write the value for the required PWM period.
3. In the TIM channel x registers (TCHxH:TCHxL), write the value for the required pulse width.
4. In TIM channel x status and control register (TSCx):
  - a. Write 0:1 (for unbuffered output compare or PWM signals) or 1:0 (for buffered output compare or PWM signals) to the mode select bits, MSxB:MSxA. See [Table 22-3](#).
  - b. Write 1 to the toggle-on-overflow bit, TOVx.
  - c. Write 1:0 (polarity 1 — to clear output on compare) or 1:1 (polarity 0 — to set out on compare) to the edge/level select bits, ELSxB:ELSxA. The output action on compare must force the output to the complement of the pulse width level. (See [Table 22-3](#).)

#### NOTE

*In PWM signal generation, do not program the PWM channel to toggle on output compare. Toggling on output compare prevents reliable 0% duty cycle generation and removes the ability of the channel to self-correct in the event of software error or noise. Toggling on output compare can also*

*cause incorrect PWM signal generation when changing the PWM pulse width to a new, much larger value.*

5. In the TIM status control register (TSC), clear the TIM stop bit, TSTOP.

Setting MS0B links channels 0 and 1 and configures them for buffered PWM operation. The TIM channel 0 registers (TCH0H:TCH0L) initially control the buffered PWM output. TIM status control register 0 (TSCR0) controls and monitors the PWM signal from the linked channels.

Clearing the toggle-on-overflow bit, TOVx, inhibits output toggles on TIM overflows. Subsequent output compares try to force the output to a state it is already in and have no effect. The result is a 0% duty cycle output.

Setting the channel x maximum duty cycle bit (CHxMAX) and setting the TOVx bit generates a 100% duty cycle output. (See TIM Channel Status and Control Registers.)

## 22.5 Interrupts

The following TIM sources can generate interrupt requests:

- TIM overflow flag (TOF) — The TOF bit is set when the TIM counter reaches the modulo value programmed in the TIM counter modulo registers. The TIM overflow interrupt enable bit, TOIE, enables TIM overflow CPU interrupt requests. TOF and TOIE are in the TIM status and control register.
- TIM channel flags (CH1F:CH0F) — The CHxF bit is set when an input capture or output compare occurs on channel x. Channel x TIM CPU interrupt requests are controlled by the channel x interrupt enable bit, CHxIE. Channel x TIM CPU interrupt requests are enabled when CHxIE = 1. CHxF and CHxIE are in the TIM channel x status and control register.

## 22.6 Low-Power Modes

The WAIT and STOP instructions put the MCU in low power- consumption standby modes.

### 22.6.1 Wait Mode

The TIM remains active after the execution of a WAIT instruction. In wait mode, the TIM registers are not accessible by the CPU. Any enabled CPU interrupt request from the TIM can bring the MCU out of wait mode.

If TIM functions are not required during wait mode, reduce power consumption by stopping the TIM before executing the WAIT instruction.

### 22.6.2 Stop Mode

The TIM is inactive after the execution of a STOP instruction. The STOP instruction does not affect register conditions or the state of the TIM counter. TIM operation resumes when the MCU exits stop mode after an external interrupt.

## 22.7 TIM During Break Interrupts

A break interrupt stops the TIM counter and inhibits input captures.

The system integration module (SIM) controls whether status bits in other modules can be cleared during the break state. The BCFE bit in the SIM break flag control register (SBFCR) enables software to clear status bits during the break state. See SIM Break Flag Control Register.

To allow software to clear status bits during a break interrupt, write a 1 to the BCFE bit. If a status bit is cleared during the break state, it remains cleared when the MCU exits the break state.

To protect status bits during the break state, write a 0 to the BCFE bit. With BCFE at 0 (its default state), software can read and write I/O registers during the break state without affecting status bits. Some status bits have a 2-step read/write clearing procedure. If software does the first step on such a bit before the break, the bit cannot change during the break state as long as BCFE is at 0. After the break, doing the second step clears the status bit.

## 22.8 I/O Signals

Port D shares three of its pins with the TIM. The three TIM channel I/O pins are T1CH0, T1CH1 and T2CH0 as described in Pin Name Conventions.

Each channel I/O pin is programmable independently as an input capture pin or an output compare pin. T1CH0 and T2CH0 can be configured as buffered output compare or buffered PWM pins.

## 22.9 I/O Registers

### NOTE

*References to either timer 1 or timer 2 may be made in the following text by omitting the timer number. For example, TSC may generically refer to both T1SC AND T2SC.*

These I/O registers control and monitor operation of the TIM:

- TIM status and control register (TSC)
- TIM control registers (TCNTH:TCNTL)
- TIM counter modulo registers (TMODH:TMODL)
- TIM channel status and control registers (TSC0, TSC1)
- TIM channel registers (TCH0H:TCH0L, TCH1H:TCH1L)


### 22.9.1 TIM Status and Control Register

The TIM status and control register (TSC):

- Enables TIM overflow interrupts
- Flags TIM overflows
- Stops the TIM counter
- Resets the TIM counter
- Prescales the TIM counter clock

Address: T1SC, \$0020 and T2SC, \$002B

	Bit 7	6	5	4	3	2	1	Bit 0
Read:	TOF	TOIE	TSTOP	0	0	PS2	PS1	PS0
Write:	0			TRST				
Reset:	0	0	1	0	0	0	0	0

 = Unimplemented

**Figure 22-4. TIM Status and Control Register (TSC)**

### TOF — TIM Overflow Flag Bit

This read/write flag is set when the TIM counter reaches the modulo value programmed in the TIM counter modulo registers. Clear TOF by reading the TIM status and control register when TOF is set and then writing a 0 to TOF. If another TIM overflow occurs before the clearing sequence is complete, then writing 0 to TOF has no effect. Therefore, a TOF interrupt request cannot be lost due to inadvertent clearing of TOF. Reset clears the TOF bit. Writing a 1 to TOF has no effect.

- 1 = TIM counter has reached modulo value
- 0 = TIM counter has not reached modulo value

### TOIE — TIM Overflow Interrupt Enable Bit

This read/write bit enables TIM overflow interrupts when the TOF bit becomes set. Reset clears the TOIE bit.

- 1 = TIM overflow interrupts enabled
- 0 = TIM overflow interrupts disabled

### TSTOP — TIM Stop Bit

This read/write bit stops the TIM counter. Counting resumes when TSTOP is cleared. Reset sets the TSTOP bit, stopping the TIM counter until software clears the TSTOP bit.

- 1 = TIM counter stopped
- 0 = TIM counter active

#### **NOTE**

*Do not set the TSTOP bit before entering wait mode if the TIM is required to exit wait mode.*

*Also, when the TSTOP bit is set and the timer is configured for input capture operation, input captures are inhibited until the TSTOP bit is cleared.*

### TRST — TIM Reset Bit

Setting this write-only bit resets the TIM counter and the TIM prescaler. Setting TRST has no effect on any other registers. Counting resumes from \$0000. TRST is cleared automatically after the TIM counter is reset and always reads as logic 0. Reset clears the TRST bit.

- 1 = Prescaler and TIM counter cleared
- 0 = No effect

#### **NOTE**

*Setting the TSTOP and TRST bits simultaneously stops the TIM counter at a value of \$0000.*

### PS2–PS0 — Prescaler Select Bits

These read/write bits select either the TCLK pin or one of the seven prescaler outputs as the input to the TIM counter as [Table 22-2](#) shows. Reset clears the PS[2:0] bits.

**Table 22-2. Prescaler Selection**

PS2–PS0	TIM Clock Source
000	Internal bus clock ÷ 1
001	Internal bus clock ÷ 2
010	Internal bus clock ÷ 4
011	Internal bus clock ÷ 8
100	Internal bus clock ÷ 16
101	Internal bus clock ÷ 32
110	Internal bus clock ÷ 64
111	Not available

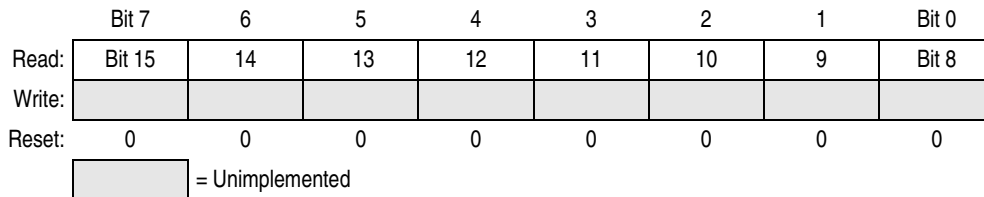
### 22.9.2 TIM Counter Registers

The two read-only TIM counter registers contain the high and low bytes of the value in the TIM counter. Reading the high byte (TCNTH) latches the contents of the low byte (TCNTL) into a buffer. Subsequent reads of TCNTH do not affect the latched TCNTL value until TCNTL is read. Reset clears the TIM counter registers. Setting the TIM reset bit (TRST) also clears the TIM counter registers.

**NOTE**

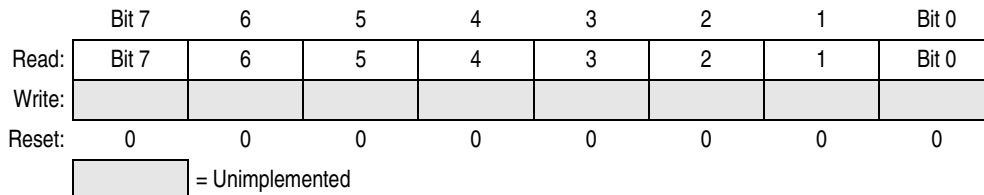
*If you read TCNTH during a break interrupt, be sure to unlatch TCNTL by reading TCNTL before exiting the break interrupt. Otherwise, TCNTL retains the value latched during the break.*

Address: T1CNTH, \$0021 and T2CNTH, \$002C



**Figure 22-5. TIM Counter Registers High (TCNTH)**

Address: T1CNTL, \$0022 and T2CNTL, \$002D



**Figure 22-6. TIM Counter Registers Low (TCNTL)**



### 22.9.3 TIM Counter Modulo Registers

The read/write TIM modulo registers contain the modulo value for the TIM counter. When the TIM counter reaches the modulo value, the overflow flag (TOF) becomes set, and the TIM counter resumes counting from \$0000 at the next timer clock. Writing to the high byte (TMODH) inhibits the TOF bit and overflow interrupts until the low byte (TMODL) is written. Reset sets the TIM counter modulo registers.

Address: T1MODH, \$0023 and T2MODH, \$002E

	Bit 7	6	5	4	3	2	1	Bit 0
Read:	Bit 15	14	13	12	11	10	9	Bit 8
Write:								
Reset:	1	1	1	1	1	1	1	1

**Figure 22-7. TIM Counter Modulo Register High (TMODH)**

Address: T1MODL, \$0024 and T2MODL, \$002F

	Bit 7	6	5	4	3	2	1	Bit 0
Read:	Bit 15	14	13	12	11	10	9	Bit 8
Write:								
Reset:	1	1	1	1	1	1	1	1

**Figure 22-8. TIM Counter Modulo Register Low (TMODL)**

**NOTE**

*Reset the TIM counter before writing to the TIM counter modulo registers.*

### 22.9.4 TIM Channel Status and Control Registers

Each of the TIM channel status and control registers:

- Flags input captures and output compares
- Enables input capture and output compare interrupts
- Selects input capture, output compare, or PWM operation
- Selects high, low, or toggling output on output compare
- Selects rising edge, falling edge, or any edge as the active input capture trigger
- Selects output toggling on TIM overflow
- Selects 0% and 100% PWM duty cycle
- Selects buffered or unbuffered output compare/PWM operation

## Timer Interface Module (TIM)

Address: T1SC0, \$0025 and T2SC0, \$0030

	Bit 7	6	5	4	3	2	1	Bit 0
Read:	CH0F	CH0IE	MS0B	MS0A	ELS0B	ELS0A	TOV0	CH0MAX
Write:	0							
Reset:	0	0	0	0	0	0	0	0

**Figure 22-9. TIM Channel 0 Status and Control Register (TSC0)**

Address: T1SC1, \$0028

	Bit 7	6	5	4	3	2	1	Bit 0
Read:	CH1F	CH1IE	0	MS1A	ELS1B	ELS1A	TOV1	CH1MAX
Write:	0							
Reset:	0	0	0	0	0	0	0	0

= Unimplemented

**Figure 22-10. TIM Channel 1 Status and Control Register (TSC1)**

### CHxF — Channel x Flag Bit

When channel x is an input capture channel, this read/write bit is set when an active edge occurs on the channel x pin. When channel x is an output compare channel, CHxF is set when the value in the TIM counter registers matches the value in the TIM channel x registers.

When TIM CPU interrupt requests are enabled (CHxIE = 1), clear CHxF by reading TIM channel x status and control register with CHxF set and then writing a 0 to CHxF. If another interrupt request occurs before the clearing sequence is complete, then writing 0 to CHxF has no effect. Therefore, an interrupt request cannot be lost due to inadvertent clearing of CHxF.

Reset clears the CHxF bit. Writing a 1 to CHxF has no effect.

- 1 = Input capture or output compare on channel x
- 0 = No input capture or output compare on channel x

### CHxIE — Channel x Interrupt Enable Bit

This read/write bit enables TIM CPU interrupt service requests on channel x.

Reset clears the CHxIE bit.

- 1 = Channel x CPU interrupt service requests enabled
- 0 = Channel x CPU interrupt service requests disabled

### MSxB — Mode Select Bit B

This read/write bit selects buffered output compare/PWM operation. MSxB exists only in the TIM1 channel 0 and TIM2 channel 0 status and control registers.

Setting MS0B disables the channel 1 status and control register and reverts TCH1 to general-purpose I/O.

Reset clears the MSxB bit.

- 1 = Buffered output compare/PWM operation enabled
- 0 = Buffered output compare/PWM operation disabled

### MSxA — Mode Select Bit A

When ELSxB:A ≠ 00, this read/write bit selects either input capture operation or unbuffered output compare/PWM operation. See [Table 22-3](#).

- 1 = Unbuffered output compare/PWM operation
- 0 = Input capture operation

When ELSxB:A = 00, this read/write bit selects the initial output level of the TCHx pin. See [Table 22-3](#). Reset clears the MSxA bit.

- 1 = Initial output level low
- 0 = Initial output level high

**NOTE**

*Before changing a channel function by writing to the MSxB or MSxA bit, set the TSTOP and TRST bits in the TIM status and control register (TSC).*

**ELSxB and ELSxA — Edge/Level Select Bits**

When channel x is an input capture channel, these read/write bits control the active edge-sensing logic on channel x.

When channel x is an output compare channel, ELSxB and ELSxA control the channel x output behavior when an output compare occurs.

When ELSxB and ELSxA are both clear, channel x is not connected to port D, and pin PTDx/TCHx is available as a general-purpose I/O pin. [Table 22-3](#) shows how ELSxB and ELSxA work. Reset clears the ELSxB and ELSxA bits.

**Table 22-3. Mode, Edge, and Level Selection**

MSxB	MSxA	ELSxB	ELSxA	Mode	Configuration
X	0	0	0	Output preset	Pin under port control; initial output level high
X	1	0	0		Pin under port control; initial output level low
0	0	0	1	Input capture	Capture on rising edge only
0	0	1	0		Capture on falling edge only
0	0	1	1		Capture on rising or falling edge
0	1	0	0	Output compare or PWM	Software compare only
0	1	0	1		Toggle output on compare
0	1	1	0		Clear output on compare
0	1	1	1		Set output on compare
1	X	0	1	Buffered output compare or buffered PWM	Toggle output on compare
1	X	1	0		Clear output on compare
1	X	1	1		Set output on compare

**NOTE**

*Before enabling a TIM channel register for input capture operation, make sure that the PTD/TCHx pin is stable for at least two bus clocks.*

**TOVx — Toggle On Overflow Bit**

When channel x is an output compare channel, this read/write bit controls the behavior of the channel x output when the TIM counter overflows. When channel x is an input capture channel, TOVx has no effect. Reset clears the TOVx bit.

- 1 = Channel x pin toggles on TIM counter overflow.
- 0 = Channel x pin does not toggle on TIM counter overflow.

**NOTE**

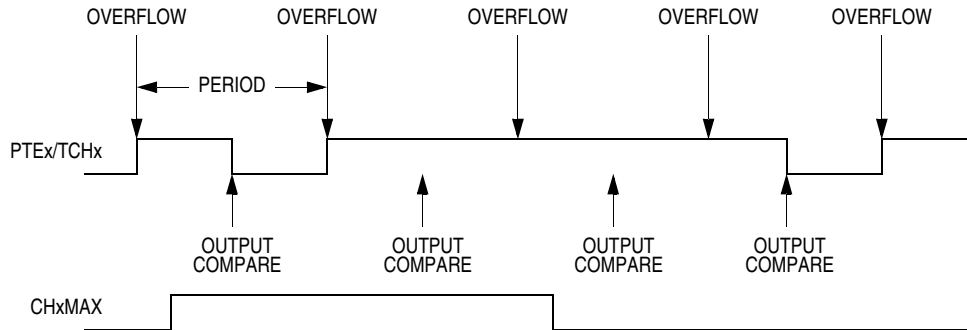
*When TOVx is set, a TIM counter overflow takes precedence over a channel x output compare if both occur at the same time.*

### CHxMAX — Channel x Maximum Duty Cycle Bit

When the TOVx bit is at 1, setting the CHxMAX bit forces the duty cycle of buffered and unbuffered PWM signals to 100%. As CHxMAX Latency shows, the CHxMAX bit takes effect in the cycle after it is set or cleared. The output stays at the 100% duty cycle level until the cycle after CHxMAX is cleared.

**NOTE**

*The 100% PWM duty cycle is defined as a continuous high level if the PWM polarity is 1 and a continuous low level if the PWM polarity is 0.*



**Figure 22-11. CHxMAX Latency**

### 22.9.5 TIM Channel Registers

These read/write registers contain the captured TIM counter value of the input capture function or the output compare value of the output compare function. The state of the TIM channel registers after reset is unknown.

In input capture mode (MSxB:MSxA = 0:0), reading the high byte of the TIM channel x registers (TCHxH) inhibits input captures until the low byte (TCHxL) is read.

In output compare mode (MSxB:MSxA ≠ 0:0), writing to the high byte of the TIM channel x registers (TCHxH) inhibits output compares until the low byte (TCHxL) is written.

Address: T1CH0H, \$0026 and T2CH0H, \$0031

	Bit 7	6	5	4	3	2	1	Bit 0
Read:	Bit 15	14	13	12	11	10	9	Bit 8
Write:								
Reset:	Indeterminate after reset							

**Figure 22-12. TIM Channel 0 Register High (TCH0H)**

Address: T1CH0L, \$0027 and T2CH0L \$0032

	Bit 7	6	5	4	3	2	1	Bit 0
Read:	Bit 7	6	5	4	3	2	1	Bit 0
Write:								
Reset:	Indeterminate after reset							

**Figure 22-13. TIM Channel 0 Register Low (TCH0L)**

Address: T1CH1H, \$0029

	Bit 7	6	5	4	3	2	1	Bit 0
Read:	Bit 15	14	13	12	11	10	9	Bit 8
Write:								
Reset:	Indeterminate after reset							

**Figure 22-14. TIM Channel 1 Register High (TCH1H)**

Address: T1CH1L, \$002A

	Bit 7	6	5	4	3	2	1	Bit 0
Read:	Bit 7	6	5	4	3	2	1	Bit 0
Write:								
Reset:	Indeterminate after reset							

**Figure 22-15. TIM Channel 1 Register Low (TCH1L)**



# Chapter 23

## Electrical Specifications

### 23.1 Absolute Maximum Ratings

Maximum ratings are the extreme limits to which the microcontroller unit (MCU) can be exposed without permanently damaging it.

**NOTE**

*This device is not guaranteed to operate properly beyond the maximum ratings. Refer to [5.0 V DC Electrical Characteristics](#) for guaranteed operating conditions.*

Characteristic <sup>(1)</sup>	Symbol	Value	Unit
Supply voltage	$V_{DD}$	-0.3 to + 6.0	V
Input voltage	$V_{In}$	$V_{SS} - 0.3$ to $V_{DD} + 0.3$	V
Maximum current per pin excluding $V_{DD}$ , $V_{SS}$ , and PTC0–PTC1	I	± 15	mA
Maximum current for pins PTC0–PTC1	$I_{PTC0-PTC1}$	± 25	mA
Maximum current into $V_{DD}$	$I_{mvdd}$	150	mA
Maximum current out of $V_{SS}$	$I_{mvss}$	150	mA
Storage temperature	$T_{stg}$	-55 to +150	°C

1. Voltages referenced to  $V_{SS}$

**NOTE**

*This device contains circuitry to protect the inputs against damage due to high static voltages or electric fields; however, it is advised that normal precautions be taken to avoid application of any voltage higher than maximum-rated voltages to this high-impedance circuit. For proper operation, it is recommended that  $V_{In}$  and  $V_{Out}$  be constrained to the range  $V_{SS} \leq (V_{In} \text{ or } V_{Out}) \leq V_{DD}$ . Reliability of operation is enhanced if unused inputs are connected to an appropriate logic voltage level (for example, either  $V_{SS}$  or  $V_{DD}$ ).*

## 23.2 Functional Operating Range

Characteristic	Symbol	Value	Unit
Operating temperature range	$T_A$	-40 to +125	°C
Operating voltage range	$V_{DD}$	3.0 ±10% 5.0 ±10%	V

### NOTE

To ensure correct operation of the MCU under all operating conditions, the user must write data \$1C to address \$0033 immediately after reset. This is to ensure proper termination of an unused module within the MCU.

## 23.3 Thermal Characteristics

Characteristic	Symbol	Value	Unit
Thermal resistance PDIP (28-pin) SOIC (28-pin) QFP (32-pin) SDIP (42-pin)	$\theta_{JA}$	60 60 95 57	°C/W
I/O pin power dissipation	$P_{I/O}$	User-Determined	W
Power dissipation <sup>(1)</sup>	$P_D$	$P_D = (I_{DD} \times V_{DD}) + P_{I/O} =$ $K/(T_J + 273 \text{ }^\circ\text{C})$	W
Constant <sup>(2)</sup>	K	$P_D \times (T_A + 273 \text{ }^\circ\text{C})$ $+ P_D^2 \times \theta_{JA}$	W/°C
Average junction temperature	$T_J$	$T_A + (P_D \times \theta_{JA})$	°C
Maximum junction temperature	$T_{JM}$	140	°C

1. Power dissipation is a function of temperature.

2. K is a constant unique to the device. K can be determined for a known  $T_A$  and measured  $P_D$ . With this value of K,  $P_D$  and  $T_J$  can be determined for any value of  $T_A$ .



## 23.4 5.0 V DC Electrical Characteristics

Characteristic <sup>(1)</sup>	Symbol	Min	Typ <sup>(2)</sup>	Max	Unit
Output high voltage ( $I_{Load} = -2.0$ mA) all I/O pins	$V_{OH}$	$V_{DD} - 0.8$	—	—	V
( $I_{Load} = -10.0$ mA) all I/O pins	$V_{OH}$	$V_{DD} - 1.5$	—	—	V
( $I_{Load} = -10.0$ mA) pins PTC0–PTC1 only	$V_{OH}$	$V_{DD} - 0.8$	—	—	V
Maximum combined $I_{OH}$ for port C, port E, port PTD0–PTD3	$I_{OH1}$	—	—	50	mA
Maximum combined $I_{OH}$ for port PTD4–PTD6, port A, port B	$I_{OH2}$	—	—	50	mA
Maximum total $I_{OH}$ for all port pins	$I_{OHT}$	—	—	100	mA
Output low voltage ( $I_{Load} = 1.6$ mA) all I/O pins	$V_{OL}$	—	—	0.4	V
( $I_{Load} = 10$ mA) all I/O pins	$V_{OL}$	—	—	1.5	V
( $I_{Load} = 15$ mA) pins PTC0–PTC1 only	$V_{OL}$	—	—	1.0	V
Maximum combined $I_{OL}$ for port C, port E, port PTD0–PTD3	$I_{OL1}$	—	—	50	mA
Maximum combined $I_{OL}$ for port PTD4–PTD6, port A, port B	$I_{OL2}$	—	—	50	mA
Maximum total $I_{OL}$ for all port pins	$I_{OLT}$	—	—	100	mA
Input high voltage All ports, IRQs, RESET OSC1	$V_{IH}$	$0.7 \times V_{DD}$ $0.8 \times V_{DD}$	—	$V_{DD}$	V
Input low voltage All ports, IRQs, RESET, OSC1	$V_{IL}$	$V_{SS}$	—	$0.2 \times V_{DD}$	V
$V_{DD}$ supply current					
Run <sup>(3)</sup>		—	15	20	mA
Wait <sup>(4)</sup>		—	4	8	mA
Stop <sup>(5)</sup> (<85 °C)	$I_{DD}$	—	3	5	μA
Stop (>85 °C)		—	5	10	μA
Stop with TBM enabled <sup>(6)</sup>		—	20	35	μA
Stop with LVI and TBM enabled <sup>(6)</sup>		—	300	500	μA
DC injection current <sup>(7), (8), (9), (10)</sup>					
Single pin limit					
$V_{IN} > V_{DD}$	$I_{IC}$	0	—	2	mA
$V_{IN} < V_{SS}$		0	—	-0.2	
Total MCU limit, includes sum of all stressed pins					
$V_{IN} > V_{DD}$		0	—	25	mA
$V_{IN} < V_{SS}$		0	—	-5	
I/O ports Hi-Z leakage current <sup>(11)</sup>	$I_{IL}$	—	—	±10	μA
Input current	$I_{In}$	—	—	1	μA
Pullup resistors (as input only) Ports PTA3/KBD3–PTA0/KBD0, PTC1–PTC0, PTD6/T2CH0–PTD0/SS	$R_{PU}$	20	45	65	kΩ

Continued on next page

## Electrical Specifications

Characteristic <sup>(1)</sup>	Symbol	Min	Typ <sup>(2)</sup>	Max	Unit
Capacitance Ports (as input or output)	$C_{Out}$ $C_{In}$	— —	— —	12 8	pF
Monitor mode entry voltage	$V_{TST}$	$V_{DD} + 2.5$	—	8.5	V
Low-voltage inhibit, trip falling voltage – target	$V_{TRIPF}$	3.85	4.25	4.50	V
Low-voltage inhibit, trip rising voltage – target	$V_{TRIPR}$	3.95	4.35	4.60	V
Low-voltage inhibit reset/recover hysteresis – target ( $V_{TRIPF} + V_{HYS} = V_{TRIPR}$ )	$V_{HYS}$	—	100	—	mV
Input hysteresis (alternative input functions only) <sup>(7), (12)</sup>	$V_{InHYS}$	$0.06 \times V_{DD}$	—	—	V
POR rearm voltage <sup>(7), (13)</sup>	$V_{POR}$	0	—	100	mV
POR reset voltage <sup>(14)</sup>	$V_{PORRST}$	0	700	800	mV
POR rise time ramp rate <sup>(7), (15)</sup>	$R_{POR}$	0.035	—	—	V/ms

- $V_{DD} = 5.0 \text{ Vdc} \pm 10\%$ ,  $V_{SS} = 0 \text{ Vdc}$ ,  $T_A = T_L$  to  $T_H$ , unless otherwise noted
- Typical values reflect average measurements at midpoint of voltage range, 25 °C only.
- Run (operating)  $I_{DD}$  measured using external square wave clock source ( $f_{OSC} = 32.8 \text{ MHz}$ ). All inputs 0.2 V from rail. No dc loads. Less than 100 pF on all outputs.  $C_L = 20 \text{ pF}$  on OSC2. All ports configured as inputs. OSC2 capacitance linearly affects run  $I_{DD}$ . Measured with all modules enabled.
- Wait  $I_{DD}$  measured using external square wave clock source ( $f_{OSC} = 32.8 \text{ MHz}$ ). All inputs 0.2 V from rail. No dc loads. Less than 100 pF on all outputs.  $C_L = 20 \text{ pF}$  on OSC2. All ports configured as inputs. OSC2 capacitance linearly affects wait  $I_{DD}$ . Measured with PLL and LVI enabled.
- Stop  $I_{DD}$  is measured with  $OSC1 = V_{SS}$ .
- Stop  $I_{DD}$  with TBM enabled is measured using an external square wave clock source ( $f_{OSC} = 32.8 \text{ KHz}$ ). All inputs 0.2 V from rail. No dc loads. Less than 100 pF on all outputs. All ports configured as inputs.
- This parameter is characterized and not tested on each device.
- All functional non-supply pins are internally clamped to  $V_{SS}$  and  $V_{DD}$ .
- Input must be current limited to the value specified. To determine the value of the required current-limiting resistor, calculate resistance values for positive and negative clamp voltages, then use the larger of the two values.
- Power supply must maintain regulation within operating  $V_{DD}$  range during instantaneous and operating maximum current conditions. If positive injection current ( $V_{IN} > V_{DD}$ ) is greater than  $I_{DD}$ , the injection current may flow out of  $V_{DD}$  and could result in external power supply going out of regulation. Ensure external  $V_{DD}$  load will shunt current greater than maximum injection current. This will be the greatest risk when the MCU is not consuming power. Examples are: if no system clock is present, or if clock rate is very low (which would reduce overall power consumption).
- Pullups and pulldowns are disabled. Port B leakage is specified in [23.12 ADC Characteristics](#).
- Digital inputs have hysteresis whenever they are configured for any alternative peripheral input function other than as a general-purpose input.
- Maximum is highest voltage that POR is guaranteed.
- Maximum is highest voltage that POR is possible.
- If minimum  $V_{DD}$  is not reached before the internal POR reset is released,  $\overline{RST}$  must be driven low externally until minimum  $V_{DD}$  is reached.

## 23.5 3.0 V DC Electrical Characteristics

Characteristic <sup>(1)</sup>	Symbol	Min	Typ <sup>(2)</sup>	Max	Unit
Output high voltage ( $I_{Load} = -0.6$ mA) all I/O pins	$V_{OH}$	$V_{DD} - 0.3$	—	—	V
( $I_{Load} = -4.0$ mA) all I/O pins	$V_{OH}$	$V_{DD} - 1.0$	—	—	V
( $I_{Load} = -4.0$ mA) pins PTC0–PTC1 only	$V_{OH}$	$V_{DD} - 0.5$	—	—	V
Maximum combined $I_{OH}$ for port C, port E, port PTD0–PTD3	$I_{OH1}$	—	—	30	mA
Maximum combined $I_{OH}$ for port PTD4–PTD6, port A, port B	$I_{OH2}$	—	—	30	mA
Maximum total $I_{OH}$ for all port pins	$I_{OHT}$	—	—	60	mA
Output low voltage ( $I_{Load} = 0.5$ mA) all I/O pins	$V_{OL}$	—	—	0.3	V
( $I_{Load} = 6.0$ mA) all I/O pins	$V_{OL}$	—	—	1.0	V
( $I_{Load} = 10.0$ mA) pins PTC0–PTC1 only	$V_{OL}$	—	—	0.8	V
Maximum combined $I_{OL}$ for port C, port E, port PTD0–PTD3	$I_{OL1}$	—	—	30	mA
Maximum combined $I_{OL}$ for port PTD4–PTD6, port A, port B	$I_{OL2}$	—	—	30	mA
Maximum total $I_{OL}$ for all port pins	$I_{OLT}$	—	—	60	mA
Input high voltage All ports, IRQs, RESET OSC1	$V_{IH}$	$0.7 \times V_{DD}$ $0.8 \times V_{DD}$	—	$V_{DD}$	V
Input low voltage All ports, IRQs, RESET OSC1	$V_{IL}$	$V_{SS}$	—	$0.3 \times V_{DD}$ $0.2 \times V_{DD}$	V
$V_{DD}$ supply current Run <sup>(3)</sup>	$I_{DD}$	—	4.5	8	mA
Wait <sup>(4)</sup>		—	1.65	4	mA
Stop <sup>(5)</sup> (<85 °C)		—	1	3	μA
Stop (>85 °C)		—	3	6	μA
Stop with TBM enabled <sup>(6)</sup>		—	12	20	μA
Stop with LVI and TBM enabled <sup>(6)</sup>		—	200	300	μA
DC injection current <sup>(7), (8), (9), (10)</sup> Single pin limit $V_{IN} > V_{DD}$ $V_{IN} < V_{SS}$	$I_{IC}$	0	—	2	mA
Total MCU limit, includes sum of all stressed pins $V_{IN} > V_{DD}$ $V_{IN} < V_{SS}$		0	—	25	
		0	—	–5	
		0	—	–5	
I/O ports Hi-Z leakage current <sup>(11)</sup>	$I_{IL}$	—	—	±10	μA
Input current	$I_{In}$	—	—	1	μA

Continued on next page

## Electrical Specifications

Characteristic <sup>(1)</sup>	Symbol	Min	Typ <sup>(2)</sup>	Max	Unit
Pullup resistors (as input only) Ports PTA3/KBD37–PTA0/KBD0, PTC1–PTC0, PTD6/T2CH0–PTD0/SS	R <sub>PU</sub>	20	45	65	kΩ
Capacitance Ports (as input or output)	C <sub>Out</sub> C <sub>In</sub>	— —	— —	12 8	pF
Monitor mode entry voltage	V <sub>TST</sub>	V <sub>DD</sub> +2.5	—	V <sub>DD</sub> +4.0	V
Low-voltage inhibit, trip falling voltage – target	V <sub>TRIPF</sub>	2.35	2.60	2.70	V
Low-voltage inhibit, trip rising voltage – target	V <sub>TRIPR</sub>	2.45	2.66	2.80	V
Low-voltage inhibit reset/recover hysteresis – target (V <sub>TRIPF</sub> + V <sub>HYS</sub> = V <sub>TRIPR</sub> )	V <sub>HYS</sub>	—	60	—	mV
Input hysteresis (alternative input functions only) <sup>(7), (12)</sup>	V <sub>InHYS</sub>	0.06 x V <sub>DD</sub>	—	—	V
POR rearm voltage <sup>(7), (13)</sup>	V <sub>POR</sub>	0	—	100	mV
POR reset voltage <sup>(14)</sup>	V <sub>PORRST</sub>	0	700	800	mV
POR rise time ramp rate <sup>(7), (15)</sup>	R <sub>POR</sub>	0.035	—	—	V/ms

- V<sub>DD</sub> = 3.0 Vdc ± 10%, V<sub>SS</sub> = 0 Vdc, T<sub>A</sub> = T<sub>L</sub> to T<sub>H</sub>, unless otherwise noted
- Typical values reflect average measurements at midpoint of voltage range, 25 °C only.
- Run (operating) I<sub>DD</sub> measured using external square wave clock source (f<sub>OSC</sub> = 16.4 MHz). All inputs 0.2 V from rail. No dc loads. Less than 100 pF on all outputs. C<sub>L</sub> = 20 pF on OSC2. All ports configured as inputs. OSC2 capacitance linearly affects run I<sub>DD</sub>. Measured with all modules enabled.
- Wait I<sub>DD</sub> measured using external square wave clock source (f<sub>OSC</sub> = 16.4 MHz). All inputs 0.2 V from rail. No dc loads. Less than 100 pF on all outputs. C<sub>L</sub> = 20 pF on OSC2. All ports configured as inputs. OSC2 capacitance linearly affects wait I<sub>DD</sub>. Measured with PLL and LVI enabled.
- Stop I<sub>DD</sub> is measured with OSC1 = V<sub>SS</sub>.
- Stop I<sub>DD</sub> with TBM enabled is measured using an external square wave clock source (f<sub>OSC</sub> = 32.8 KHz). All inputs 0.2 V from rail. No dc loads. Less than 100 pF on all outputs. All ports configured as inputs.
- This parameter is characterized and not tested on each device.
- All functional non-supply pins are internally clamped to V<sub>SS</sub> and V<sub>DD</sub>.
- Input must be current limited to the value specified. To determine the value of the required current-limiting resistor, calculate resistance values for positive and negative clamp voltages, then use the larger of the two values.
- Power supply must maintain regulation within operating V<sub>DD</sub> range during instantaneous and operating maximum current conditions. If positive injection current (V<sub>IN</sub> > V<sub>DD</sub>) is greater than I<sub>DD</sub>, the injection current may flow out of V<sub>DD</sub> and could result in external power supply going out of regulation. Ensure external V<sub>DD</sub> load will shunt current greater than maximum injection current. This will be the greatest risk when the MCU is not consuming power. Examples are: if no system clock is present, or if clock rate is very low (which would reduce overall power consumption).
- Pullups and pulldowns are disabled.
- Digital inputs have hysteresis whenever they are configured for any alternative peripheral input function other than as a general-purpose input.
- Maximum is highest voltage that POR is guaranteed.
- Maximum is highest voltage that POR is possible.
- If minimum V<sub>DD</sub> is not reached before the internal POR reset is released,  $\overline{\text{RST}}$  must be driven low externally until minimum V<sub>DD</sub> is reached.

## 23.6 5.0 V Control Timing

Characteristic <sup>(1)</sup>	Symbol	Min	Max	Unit
Frequency of operation <sup>(2)</sup> Crystal option External clock option <sup>(3)</sup>	$f_{osc}$	32 dc <sup>(4)</sup>	100 32.8	kHz MHz
Internal operating frequency	$f_{op}$	—	8.2	MHz
Internal clock period ( $1/f_{OP}$ )	$t_{cyc}$	122	—	ns
$\overline{RST}$ input pulse width low <sup>(5)</sup>	$t_{IRL}$	50	—	ns
$\overline{IRQ}$ interrupt pulse width low <sup>(6)</sup> (edge-triggered)	$t_{LIH}$	50	—	ns
$\overline{IRQ}$ interrupt pulse period	$t_{LIL}$	Note 8	—	$t_{cyc}$
16-bit timer <sup>(7)</sup> Input capture pulse width Input capture period	$t_{TH}, t_{TL}$ $t_{TLTL}$	Note 8	— —	ns $t_{cyc}$

1.  $V_{SS} = 0$  Vdc; timing shown with respect to 20%  $V_{DD}$  and 70%  $V_{SS}$  unless otherwise noted.

2. See [23.8 Clock Generation Module Characteristics](#) for more information.

3. No more than 10% duty cycle deviation from 50%

4. Some modules may require a minimum frequency greater than dc for proper operation. See appropriate table for this information.

5. Minimum pulse width reset is guaranteed to be recognized. It is possible for a smaller pulse width to cause a reset.

6. Minimum pulse width is for guaranteed interrupt. It is possible for a smaller pulse width to be recognized.

7. Minimum pulse width is for guaranteed interrupt. It is possible for a smaller pulse width to be recognized.

8. The minimum period,  $t_{LIL}$  or  $t_{TLTL}$ , should not be less than the number of cycles it takes to execute the interrupt service routine plus  $t_{cyc}$ .

## 23.7 3.0 V Control Timing

Characteristic <sup>(1)</sup>	Symbol	Min	Max	Unit
Frequency of operation <sup>(2)</sup> Crystal option External clock option <sup>(3)</sup>	$f_{osc}$	32 dc <sup>(4)</sup>	100 16.4	kHz MHz
Internal operating frequency	$f_{op}$	—	4.1	MHz
Internal clock period ( $1/f_{OP}$ )	$t_{cyc}$	244	—	ns
$\overline{RST}$ input pulse width low <sup>(5)</sup>	$t_{IRL}$	125	—	ns
$\overline{IRQ}$ interrupt pulse width low <sup>(6)</sup> (edge-triggered)	$t_{LIH}$	125	—	ns
$\overline{IRQ}$ interrupt pulse period	$t_{LIL}$	Note 8	—	$t_{cyc}$
16-bit timer <sup>(7)</sup> Input capture pulse width Input capture period	$t_{TH}, t_{TL}$ $t_{TLTL}$	Note 8	— —	ns $t_{cyc}$

1.  $V_{SS} = 0$  Vdc; timing shown with respect to 20%  $V_{DD}$  and 70%  $V_{SS}$  unless otherwise noted.

2. See [23.8 Clock Generation Module Characteristics](#) for more information.

3. No more than 10% duty cycle deviation from 50%

4. Some modules may require a minimum frequency greater than dc for proper operation. See appropriate table for this information.

5. Minimum pulse width reset is guaranteed to be recognized. It is possible for a smaller pulse width to cause a reset.

6. Minimum pulse width is for guaranteed interrupt. It is possible for a smaller pulse width to be recognized.

7. Minimum pulse width is for guaranteed interrupt. It is possible for a smaller pulse width to be recognized.

8. The minimum period,  $t_{LIL}$  or  $t_{TLTL}$ , should not be less than the number of cycles it takes to execute the interrupt service routine plus  $t_{CYC}$ .

## 23.8 Clock Generation Module Characteristics

### 23.8.1 CGM Component Specifications

Characteristic	Symbol	Min	Typ	Max	Unit
Crystal reference frequency	$f_{XCLK}$	30	32.768	100	kHz
Crystal load capacitance <sup>(1)</sup>	$C_L$	—	12.5	—	pF
Crystal fixed capacitance <sup>(2)</sup>	$C_1$	—	15	—	pF
Crystal tuning capacitance <sup>(2)</sup>	$C_2$	—	15	—	pF
Feedback bias resistor	$R_B$	1	10	22	M $\Omega$
Series resistor <sup>(3)</sup>	$R_S$	100	330	470	k $\Omega$

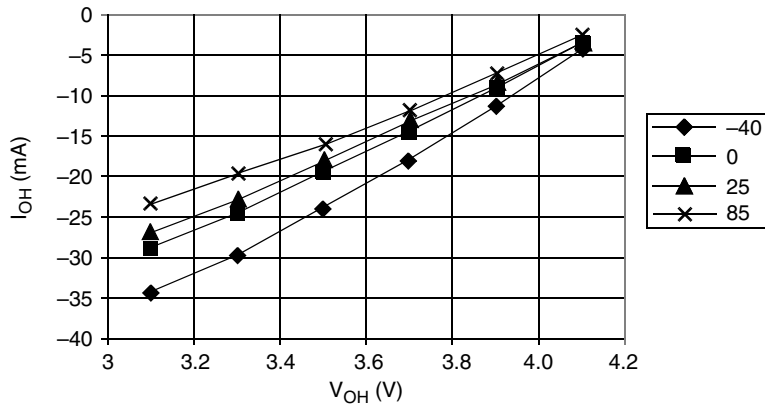
1. Crystal manufacturer value.
2. Capacitor on OSC1 pin. Does not include parasitic capacitance due to package, pin, and board.
3. Capacitor on OSC2 pin. Does not include parasitic capacitance due to package, pin, and board.

### 23.8.2 CGM Electrical Specifications

Description	Symbol	Min	Typ	Max	Unit
Operating voltage	$V_{DD}$	2.7	—	5.5	V
Operating temperature	T	−40	25	125	°C
Crystal reference frequency	$f_{RCLK}$	30	32.768	100	kHz
Range nominal multiplier	$f_{NOM}$	—	38.4	—	kHz
VCO center-of-range frequency <sup>(1)</sup>	$f_{VRS}$	38.4 k	—	40.0 M	Hz
Medium-voltage VCO center-of-range frequency <sup>(2)</sup>	$f_{VRS}$	38.4 k	—	40.0 M	Hz
VCO range linear range multiplier	L	1	—	255	
VCO power-of-two range multiplier	$2^E$	1	—	4	
VCO multiply factor	N	1	—	4095	
VCO prescale multiplier	$2^P$	1	1	8	
Reference divider factor	R	1	1	15	
VCO operating frequency	$f_{VCLK}$	38.4 k	—	40.0 M	Hz
Bus operating frequency <sup>(1)</sup>	$f_{BUS}$	—	—	8.2	MHz
Bus frequency @ medium voltage <sup>(2)</sup>	$f_{BUS}$	—	—	4.1	MHz
Manual acquisition time	$t_{Lock}$	—	—	50	ms
Automatic lock time	$t_{Lock}$	—	—	50	ms
PLL jitter <sup>(3)</sup>	$f_J$	0	—	$f_{RCLK} \times 0.025\% \times 2^P N/4$	Hz
External clock input frequency PLL disabled	$f_{OSC}$	dc	—	32.8 M	Hz
External clock input frequency PLL enabled	$f_{OSC}$	30 k	—	1.5 M	Hz

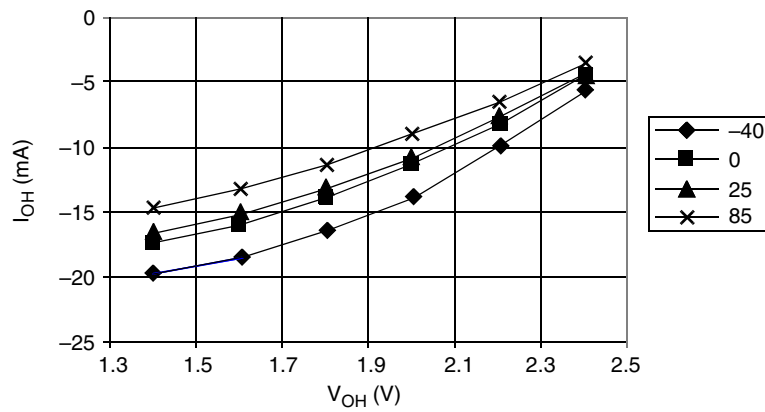
1.  $5.0 V \pm 10\% V_{DD}$
2.  $3.0 V \pm 10\% V_{DD}$
3. Deviation of average bus frequency over 2 ms. N = VCO multiplier.

## 23.9 Output High-Voltage Characteristics



$V_{OH} > V_{DD} - 0.8 \text{ V}$  @  $I_{OH} = -2.0 \text{ mA}$   
 $V_{OH} > V_{DD} - 1.5 \text{ V}$  @  $I_{OH} = -10.0 \text{ mA}$

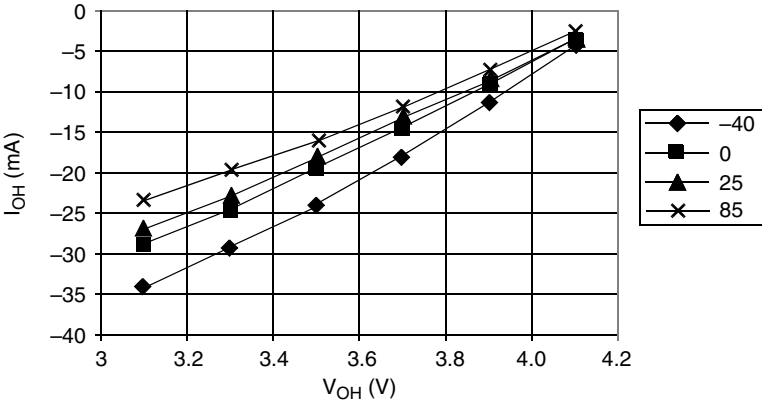
**Figure 23-1. Typical High-Side Driver Characteristics – Port PTA3–PTA0 ( $V_{DD} = 4.5 \text{ Vdc}$ )**



$V_{OH} > V_{DD} - 0.3 \text{ V}$  @  $I_{OH} = -0.6 \text{ mA}$   
 $V_{OH} > V_{DD} - 1.0 \text{ V}$  @  $I_{OH} = -4.0 \text{ mA}$

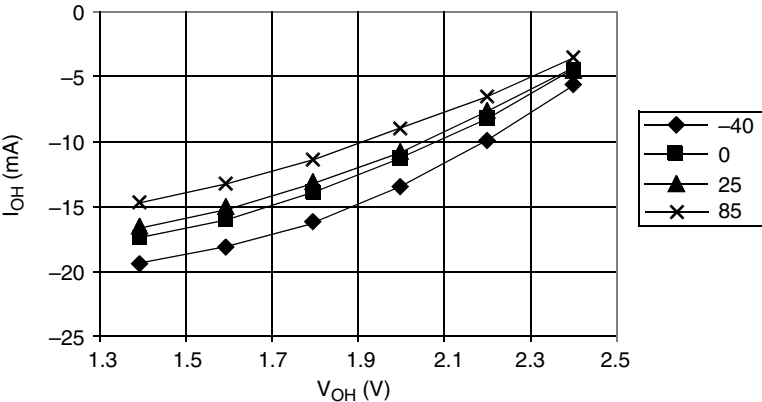
**Figure 23-2. Typical High-Side Driver Characteristics – Port PTA3–PTA0 ( $V_{DD} = 2.7 \text{ Vdc}$ )**





$V_{OH} > V_{DD} - 0.8\text{ V}$  @  $I_{OH} = -10.0\text{ mA}$

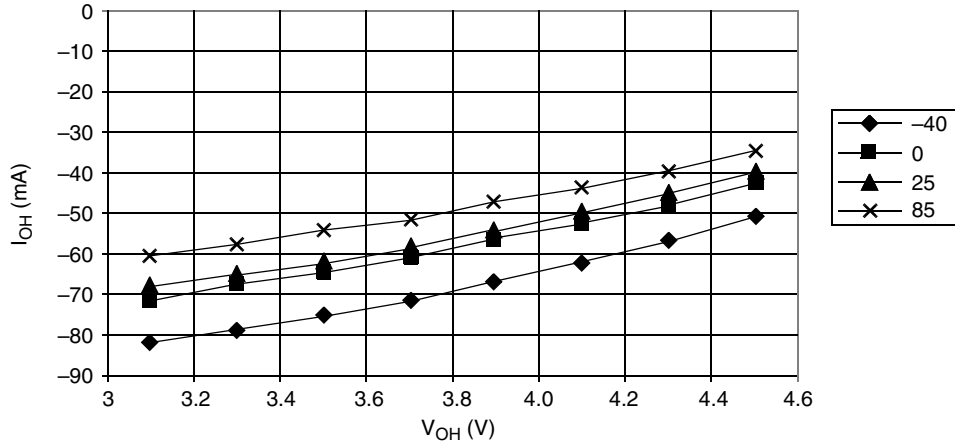
**Figure 23-3. Typical High-Side Driver Characteristics – Port PTC1–PTC0 ( $V_{DD} = 4.5\text{ Vdc}$ )**



$V_{OH} > V_{DD} - 0.5\text{ V}$  @  $I_{OH} = -4.0\text{ mA}$

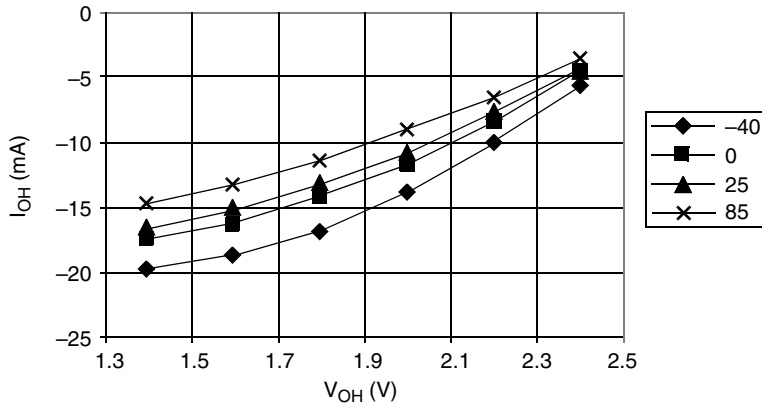
**Figure 23-4. Typical High-Side Driver Characteristics – Port PTC1–PTC0 ( $V_{DD} = 2.7\text{ Vdc}$ )**

Electrical Specifications



$V_{OH} > V_{DD} - 0.8 \text{ V}$  @  $I_{OH} = -2.0 \text{ mA}$   
 $V_{OH} > V_{DD} - 1.5 \text{ V}$  @  $I_{OH} = -10.0 \text{ mA}$

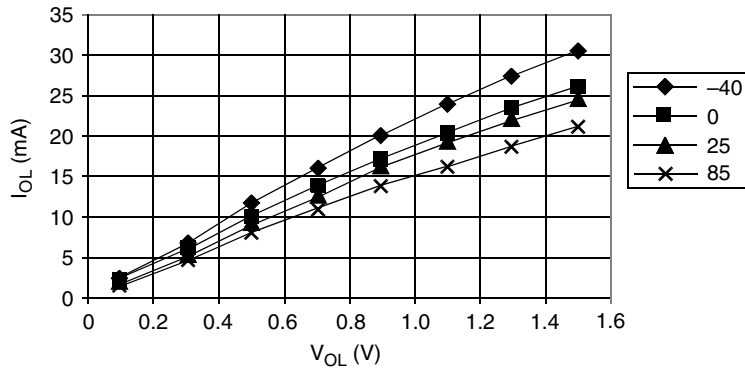
**Figure 23-5. Typical High-Side Driver Characteristics – Ports PTB5–PTB0, PTD6–PTD0, and PTE1–PTE0 ( $V_{DD} = 5.5 \text{ Vdc}$ )**



$V_{OH} > V_{DD} - 0.3 \text{ V}$  @  $I_{OH} = -0.6 \text{ mA}$   
 $V_{OH} > V_{DD} - 1.0 \text{ V}$  @  $I_{OH} = -4.0 \text{ mA}$

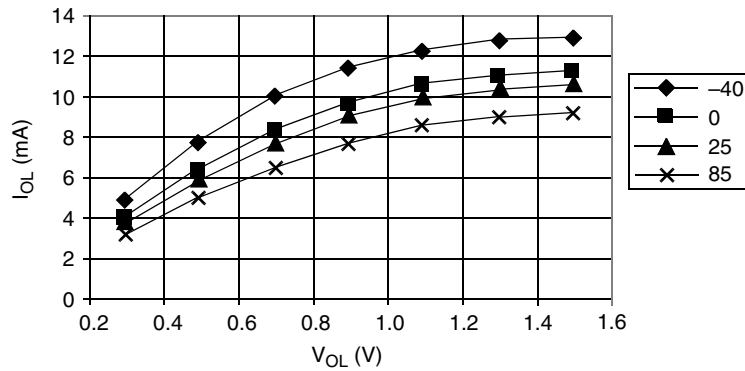
**Figure 23-6. Typical High-Side Driver Characteristics – Ports PTB5–PTB0, PTD6–PTD0, and PTE1–PTE0 ( $V_{DD} = 2.7 \text{ Vdc}$ )**

## 23.10 Output Low-Voltage Characteristics



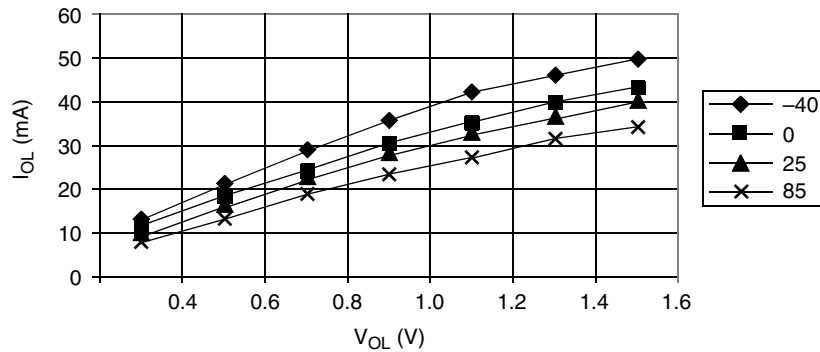
$V_{OL} < 0.4 \text{ V} @ I_{OL} = 1.6 \text{ mA}$   
 $V_{OL} < 1.5 \text{ V} @ I_{OL} = 10.0 \text{ mA}$

**Figure 23-7. Typical Low-Side Driver Characteristics – Port PTA3–PTA0 ( $V_{DD} = 5.5 \text{ Vdc}$ )**



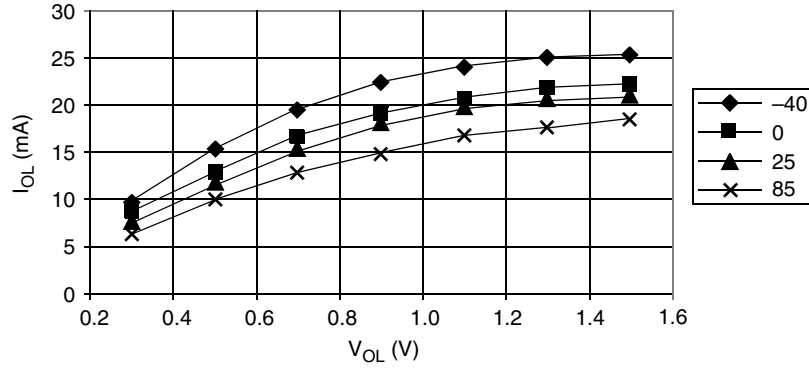
$V_{OL} < 0.3 \text{ V} @ I_{OL} = 0.5 \text{ mA}$   
 $V_{OL} < 1.0 \text{ V} @ I_{OL} = 6.0 \text{ mA}$

**Figure 23-8. Typical Low-Side Driver Characteristics – Port PTA3–PTA0 ( $V_{DD} = 2.7 \text{ Vdc}$ )**



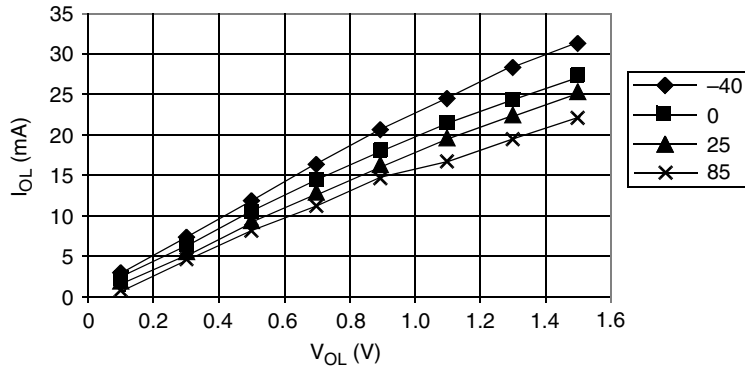
$V_{OL} < 1.0 \text{ V} @ I_{OL} = 15 \text{ mA}$

**Figure 23-9. Typical Low-Side Driver Characteristics – Port PTC1–PTC0 ( $V_{DD} = 4.5 \text{ Vdc}$ )**



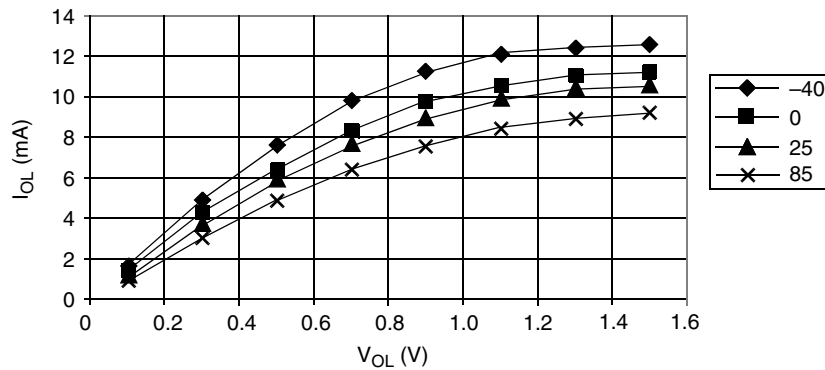
$V_{OL} < 0.8 \text{ V @ } I_{OL} = 10 \text{ mA}$

**Figure 23-10. Typical Low-Side Driver Characteristics – Port PTC1–PTC0 ( $V_{DD} = 2.7 \text{ Vdc}$ )**



$V_{OL} < 0.4 \text{ V @ } I_{OL} = 1.6 \text{ mA}$   
 $V_{OL} < 1.5 \text{ V @ } I_{OL} = 10.0 \text{ mA}$

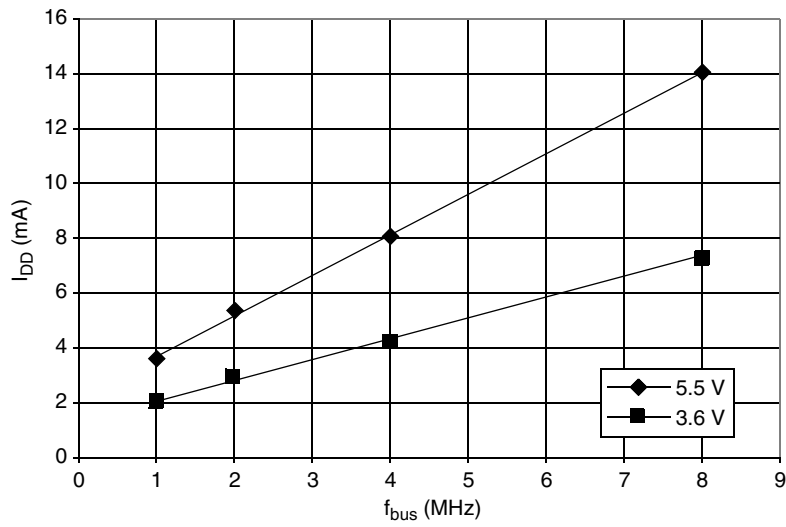
**Figure 23-11. Typical Low-Side Driver Characteristics – Ports PTB5–PTB0, PTD6–PTD0, and PTE1–PTE0 ( $V_{DD} = 5.5 \text{ Vdc}$ )**



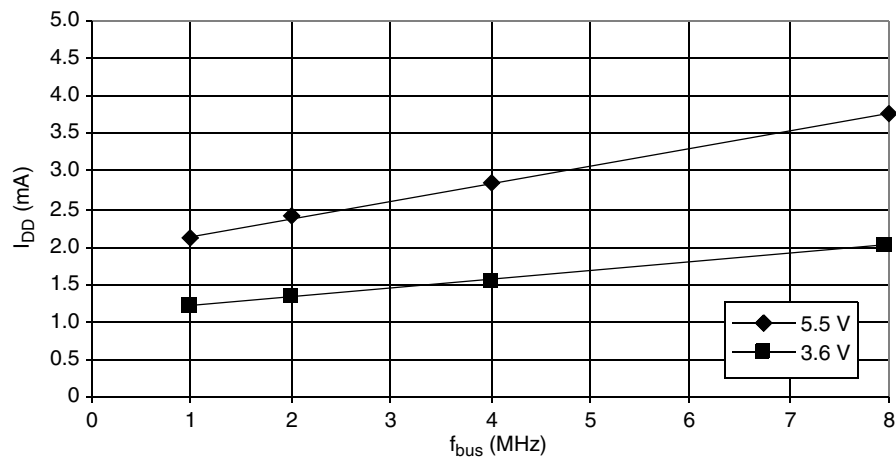
$V_{OL} < 0.3 \text{ V @ } I_{OL} = 0.5 \text{ mA}$   
 $V_{OL} < 1.0 \text{ V @ } I_{OL} = 6.0 \text{ mA}$

**Figure 23-12. Typical Low-Side Driver Characteristics – Ports PTB5–PTB0, PTD6–PTD0, and PTE1–PTE0 ( $V_{DD} = 2.7 \text{ Vdc}$ )**

## 23.11 Typical Supply Currents

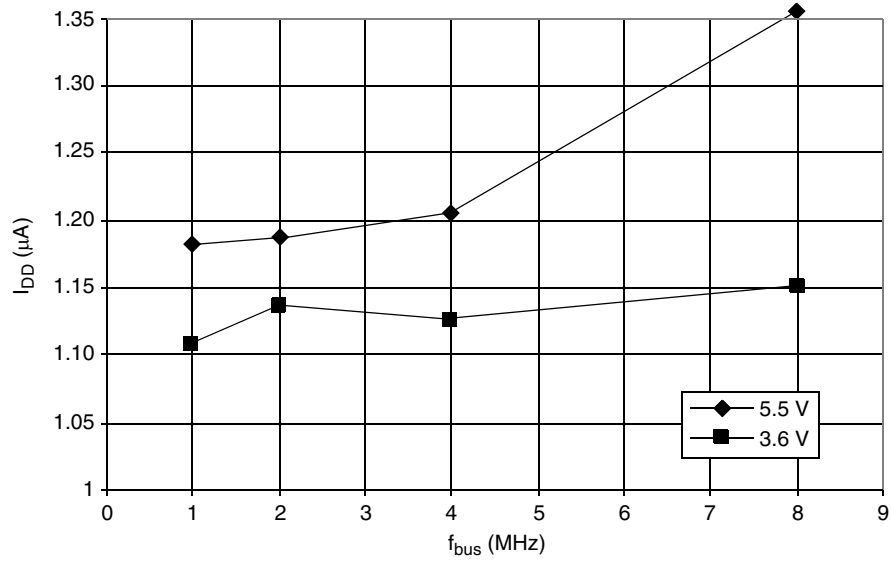


**Figure 23-13. Typical Operating  $I_{DD}$ , with All Modules Turned On ( $-40\text{ }^{\circ}\text{C}$  to  $125\text{ }^{\circ}\text{C}$ )**



**Figure 23-14. Typical Wait Mode  $I_{DD}$ , with all Modules Disabled ( $-40\text{ }^{\circ}\text{C}$  to  $125\text{ }^{\circ}\text{C}$ )**

## Electrical Specifications



**Figure 23-15. Typical Stop Mode  $I_{DD}$ , with all Modules Disabled  
( $-40\text{ }^{\circ}\text{C}$  to  $125\text{ }^{\circ}\text{C}$ )**

## 23.12 ADC Characteristics

Characteristic <sup>(1)</sup>	Symbol	Min	Max	Unit	Comments
Supply voltage	$V_{DDAD}$	2.7 ( $V_{DD}$ min)	5.5 ( $V_{DD}$ max)	V	$V_{DDAD}$ should be tied to the same potential as $V_{DD}$ via separate traces.
Input voltages	$V_{ADIN}$	0	$V_{DDAD}$	V	$V_{ADIN} \leq V_{REFH}$
Resolution	$B_{AD}$	8	8	Bits	
Absolute accuracy ( $V_{REFL} = 0$ V, $V_{DDAD} = V_{REFH} = 5$ V $\pm$ 10%)	$A_{AD}$	—	$\pm 1$	LSB	Includes quantization
ADC internal clock	$f_{ADIC}$	0.5	1.048	MHz	$t_{AIC} = 1/f_{ADIC}$ , tested only at 1 MHz
Conversion range	$R_{AD}$	$V_{REFL}$	$V_{REFH}$	V	$V_{REFH} = V_{DDAD}$ $V_{REFL} = V_{SSAD}$
Power-up time	$t_{ADPU}$	16		$t_{AIC}$ cycles	
Conversion time	$t_{ADC}$	16	17	$t_{AIC}$ cycles	
Sample time <sup>(2)</sup>	$t_{ADS}$	5	—	$t_{AIC}$ cycles	
Zero input reading <sup>(3)</sup>	$Z_{ADI}$	00	01	Hex	$V_{IN} = V_{REFL}$
Full-scale reading <sup>(3)</sup>	$F_{ADI}$	FE	FF	Hex	$V_{IN} = V_{REFH}$
Input capacitance	$C_{ADI}$	—	20	pF	Not tested
Input leakage <sup>(4)</sup> Port B	—	—	$\pm 1$	$\mu$ A	

1.  $V_{DD} = 5.0$  Vdc  $\pm$  10%,  $V_{SS} = 0$  Vdc,  $V_{DDAD} = 5.0$  Vdc  $\pm$  10%,  $V_{SSAD} = 0$  Vdc,  $V_{REFH} = 5.0$  Vdc  $\pm$  10%,  $V_{REFL} = 0$

2. Source impedances greater than 10 k $\Omega$  adversely affect internal RC charging time during input sampling.

3. Zero-input/full-scale reading requires sufficient decoupling measures for accurate conversions.

4. The external system error caused by input leakage current is approximately equal to the product of R source and input current.

## 23.13 5.0 V SPI Characteristics

Diagram Number <sup>(1)</sup>	Characteristic <sup>(2)</sup>	Symbol	Min	Max	Unit
	Operating frequency Master Slave	$f_{OP(M)}$ $f_{OP(S)}$	$f_{OP}/128$ DC	$f_{OP}/2$ $f_{OP}$	MHz MHz
1	Cycle time Master Slave	$t_{CYC(M)}$ $t_{CYC(S)}$	2 1	128 —	$t_{cyc}$ $t_{cyc}$
2	Enable lead time	$t_{Lead(S)}$	1	—	$t_{cyc}$
3	Enable lag time	$t_{Lag(S)}$	1	—	$t_{cyc}$
4	Clock (SPSCK) high time Master Slave	$t_{SCKH(M)}$ $t_{SCKH(S)}$	$t_{cyc} - 25$ $1/2 t_{cyc} - 25$	$64 t_{cyc}$ —	ns ns
5	Clock (SPSCK) low time Master Slave	$t_{SCKL(M)}$ $t_{SCKL(S)}$	$t_{cyc} - 25$ $1/2 t_{cyc} - 25$	$64 t_{cyc}$ —	ns ns
6	Data setup time (inputs) Master Slave	$t_{SU(M)}$ $t_{SU(S)}$	30 30	— —	ns ns
7	Data hold time (inputs) Master Slave	$t_{H(M)}$ $t_{H(S)}$	30 30	— —	ns ns
8	Access time, slave <sup>(3)</sup> CPHA = 0 CPHA = 1	$t_{A(CP0)}$ $t_{A(CP1)}$	0 0	40 40	ns ns
9	Disable time, slave <sup>(4)</sup>	$t_{DIS(S)}$	—	40	ns
10	Data valid time, after enable edge Master Slave <sup>(5)</sup>	$t_{V(M)}$ $t_{V(S)}$	— —	50 50	ns ns
11	Data hold time, outputs, after enable edge Master Slave	$t_{HO(M)}$ $t_{HO(S)}$	0 0	— —	ns ns

1. Numbers refer to dimensions in [Figure 23-16](#) and [Figure 23-17](#).

2. All timing is shown with respect to 20%  $V_{DD}$  and 70%  $V_{DD}$ , unless noted; 100 pF load on all SPI pins.

3. Time to data active from high-impedance state

4. Hold time to high-impedance state

5. With 100 pF on all SPI pins



## 23.14 3.0 V SPI Characteristics

Diagram Number <sup>(1)</sup>	Characteristic <sup>(2)</sup>	Symbol	Min	Max	Unit
	Operating frequency Master Slave	$f_{OP(M)}$ $f_{OP(S)}$	$f_{OP}/128$ DC	$f_{OP}/2$ $f_{OP}$	MHz MHz
1	Cycle time Master Slave	$t_{CYC(M)}$ $t_{CYC(S)}$	2 1	128 —	$t_{cyc}$ $t_{cyc}$
2	Enable lead time	$t_{Lead(s)}$	1	—	$t_{cyc}$
3	Enable lag time	$t_{Lag(s)}$	1	—	$t_{cyc}$
4	Clock (SPSCK) high time Master Slave	$t_{SCKH(M)}$ $t_{SCKH(S)}$	$t_{cyc} - 35$ $1/2 t_{cyc} - 35$	$64 t_{cyc}$ —	ns ns
5	Clock (SPSCK) low time Master Slave	$t_{SCKL(M)}$ $t_{SCKL(S)}$	$t_{cyc} - 35$ $1/2 t_{cyc} - 35$	$64 t_{cyc}$ —	ns ns
6	Data setup time (inputs) Master Slave	$t_{SU(M)}$ $t_{SU(S)}$	40 40	— —	ns ns
7	Data hold time (inputs) Master Slave	$t_{H(M)}$ $t_{H(S)}$	40 40	— —	ns ns
8	Access time, slave <sup>(3)</sup> CPHA = 0 CPHA = 1	$t_{A(CP0)}$ $t_{A(CP1)}$	0 0	50 50	ns ns
9	Disable time, slave <sup>(4)</sup>	$t_{DIS(S)}$	—	50	ns
10	Data valid time, after enable edge Master Slave <sup>(5)</sup>	$t_{V(M)}$ $t_{V(S)}$	— —	60 60	ns ns
11	Data hold time, outputs, after enable edge Master Slave	$t_{HO(M)}$ $t_{HO(S)}$	0 0	— —	ns ns

1. Numbers refer to dimensions in [Figure 23-16](#) and [Figure 23-17](#).

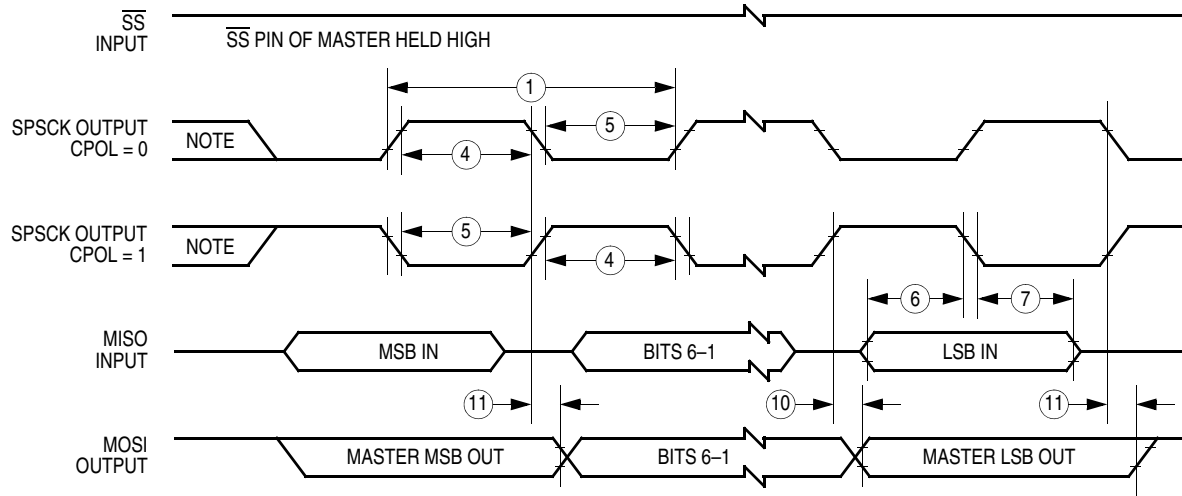
2. All timing is shown with respect to 20%  $V_{DD}$  and 70%  $V_{DD}$ , unless noted; 100 pF load on all SPI pins.

3. Time to data active from high-impedance state

4. Hold time to high-impedance state

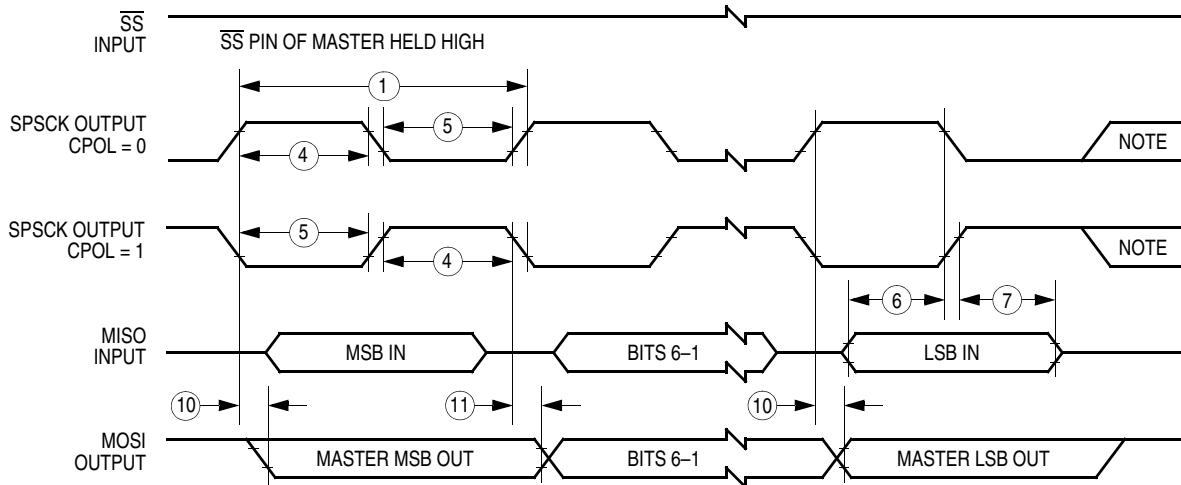
5. With 100 pF on all SPI pins

## Electrical Specifications



Note: This first clock edge is generated internally, but is not seen at the SPCK pin.

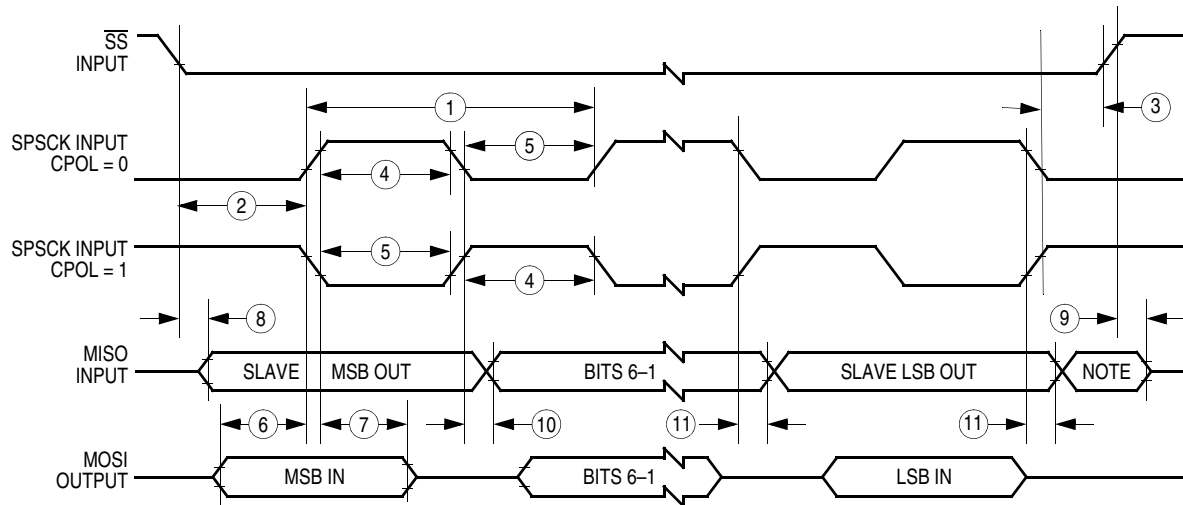
### a) SPI Master Timing (CPHA = 0)



Note: This last clock edge is generated internally, but is not seen at the SPCK pin.

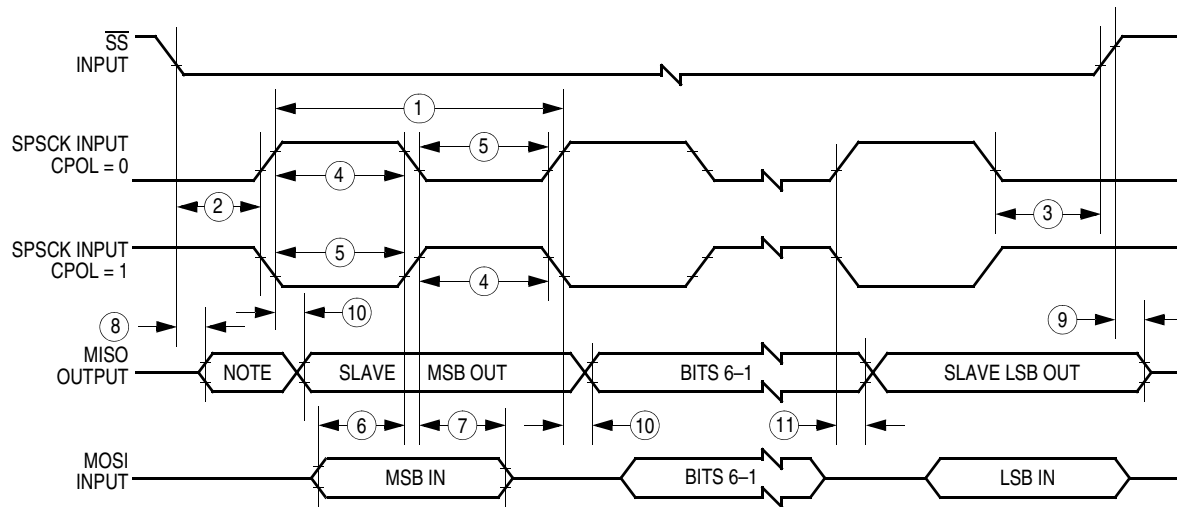
### b) SPI Master Timing (CPHA = 1)

Figure 23-16. SPI Master Timing



Note: Not defined but normally MSB of character just received

**a) SPI Slave Timing (CPHA = 0)**



Note: Not defined but normally LSB of character previously transmitted

**b) SPI Slave Timing (CPHA = 1)**

**Figure 23-17. SPI Slave Timing**

## 23.15 Timer Interface Module Characteristics

Characteristic	Symbol	Min	Max	Unit
Input capture pulse width	$t_{TIH}, t_{TIL}$	2	—	$t_{cyc}$
Timer input capture period	$t_{TLTL}$	See Note <sup>(1)</sup>	—	$t_{cyc}$

1. The minimum period is the number of cycles it takes to execute the interrupt service routine plus 1  $t_{cyc}$ .

## 23.16 Memory Characteristics

Characteristic	Symbol	Min	Typ	Max	Unit
RAM data retention voltage	$V_{RDR}$	1.3	—	—	V
FLASH program bus clock frequency	—	1	—	—	MHz
FLASH read bus clock frequency	$f_{Read}^{(1)}$	32k	—	8.4M	Hz
FLASH page erase time Limited endurance (<1 K cycles) Maximum endurance (> 1 K cycles)	$t_{Erase}$	0.9 3.6	1 4	1.1 5.5	ms
FLASH mass erase time	$t_{MErase}$	4	—	—	ms
FLASH PGM/ERASE to HVEN set up time	$t_{nvs}$	10	—	—	$\mu$ s
FLASH high-voltage hold time	$t_{nvh}$	5	—	—	$\mu$ s
FLASH high-voltage hold time (mass erase)	$t_{nvhl}$	100	—	—	$\mu$ s
FLASH program hold time	$t_{pgs}$	5	—	—	$\mu$ s
FLASH program time	$t_{PROG}$	30	—	40	$\mu$ s
FLASH return to read time	$t_{rcv}^{(2)}$	1	—	—	$\mu$ s
FLASH cumulative program HV period	$t_{HV}^{(3)}$	—	—	4	ms
FLASH endurance <sup>(4)</sup>	—	10k	100k	—	Cycles
FLASH data retention time <sup>(5)</sup>	—	15	100	—	Years

1.  $f_{Read}$  is defined as the frequency range for which the FLASH memory can be read.

2.  $t_{rcv}$  is defined as the time it needs before the FLASH can be read after turning off the high voltage charge pump, by clearing HVEN to 0.

3.  $t_{HV}$  is defined as the cumulative high voltage programming time to the same row before next erase.

$t_{HV}$  must satisfy this condition:  $t_{nvs} + t_{nvh} + t_{pgs} + (t_{PROG} \times 64) \leq t_{HV} \text{ max.}$

4. Typical endurance was evaluated for this product family. For additional information on how Freescale defines typical Endurance, please refer to Engineering Bulletin EB619.

5. Typical data retention values are based on intrinsic capability of the technology measured at high temperature and de-rated to 25°C using the Arrhenius equation. For additional information on how Freescale defines *Typical Data Retention*, please refer to Engineering Bulletin EB618.

---

# Chapter 24

## Mechanical Specifications

### 24.1 Introduction

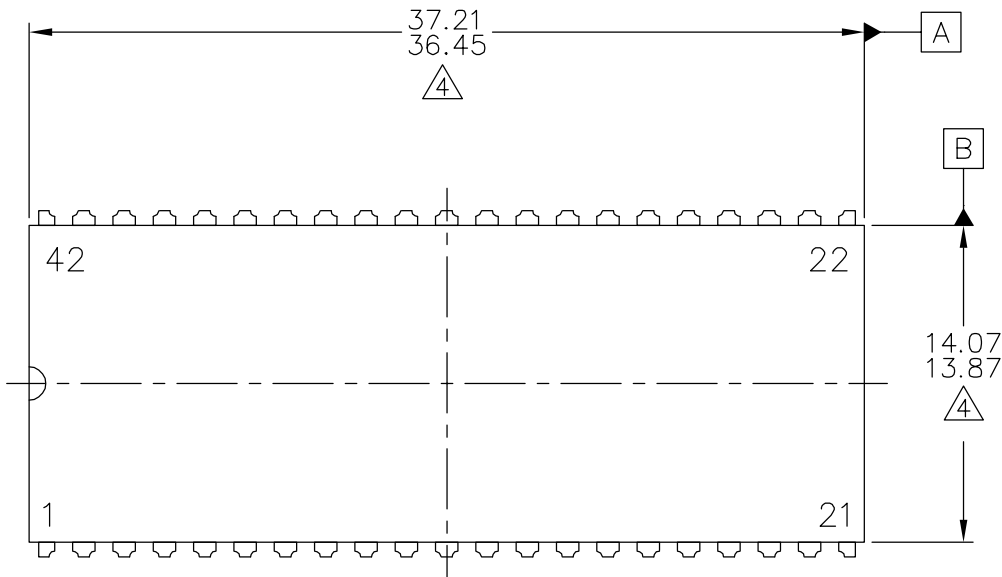
The MC68HC908GR8 and MC68HC908GR4 are available in these packages:

- 42-pin shrink dual in-line package (SDIP)
- 32-pin low-profile quad flat pack (LQFP)
- 28-pin dual in-line package (PDIP)
- 28-pin small outline package (SOIC)

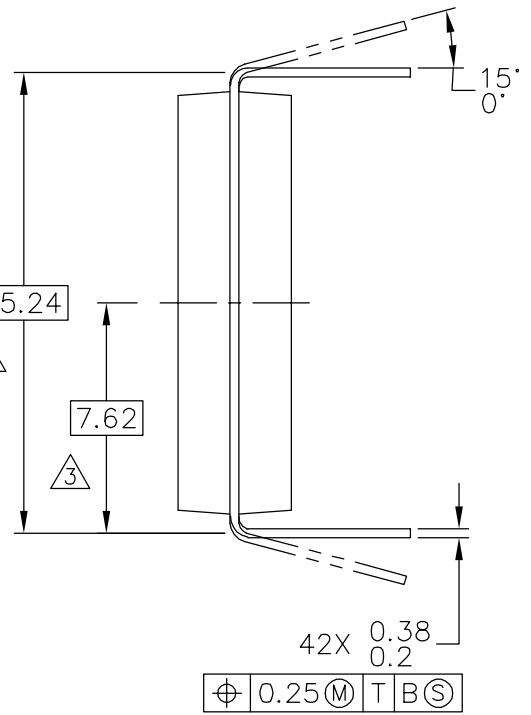
The package information contained in this section is the latest available at the time of this publication. To make sure that you have the latest package specifications, please visit the Freescale web site at:

<http://freescale.com>

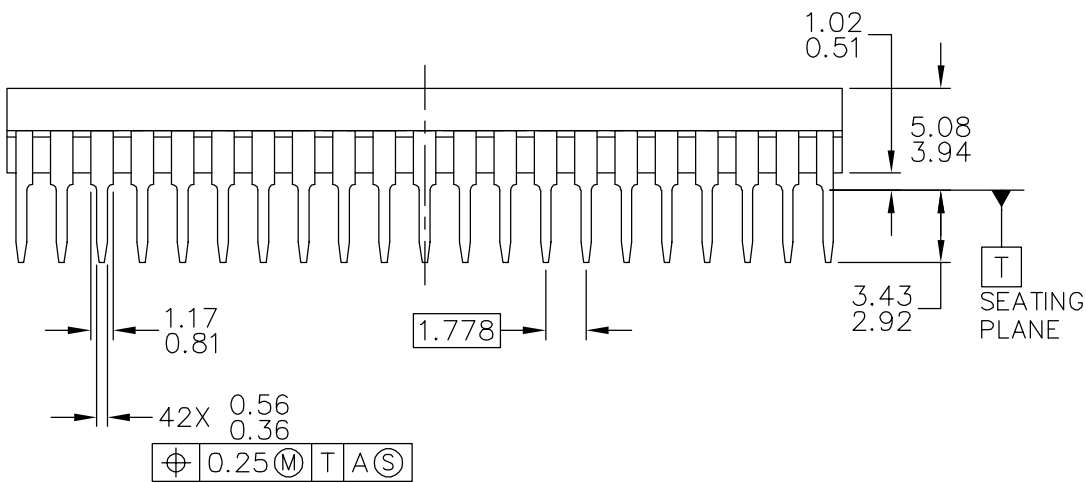
Follow World Wide Web on-line instructions to retrieve the current mechanical specifications.



TOP VIEW



END VIEW



SIDE VIEW

© FREESCALE SEMICONDUCTOR, INC. ALL RIGHTS RESERVED.	<b>MECHANICAL OUTLINE</b>	PRINT VERSION NOT TO SCALE	
TITLE:  42 LD PDIP	DOCUMENT NO: 98ASB42767B	REV: A	
	CASE NUMBER: 858-01	24 OCT 2005	
	STANDARD: NON-JEDEC		

NOTES:

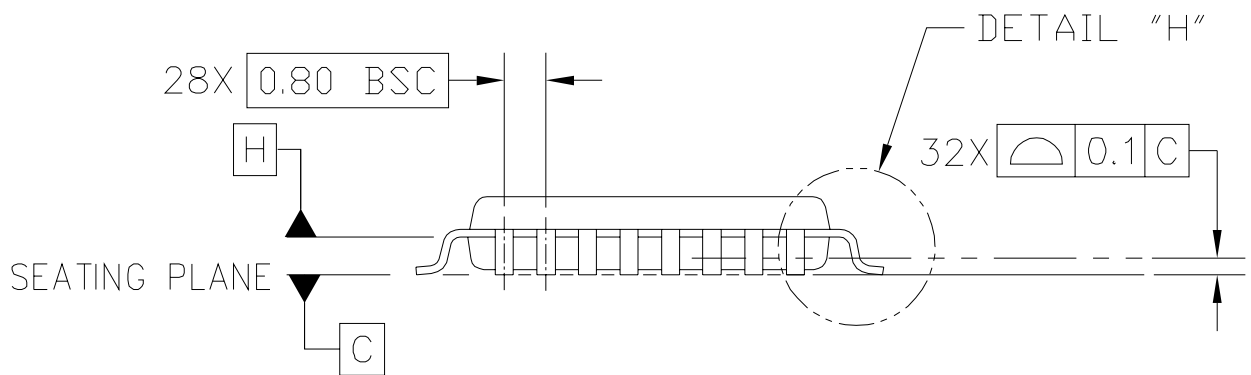
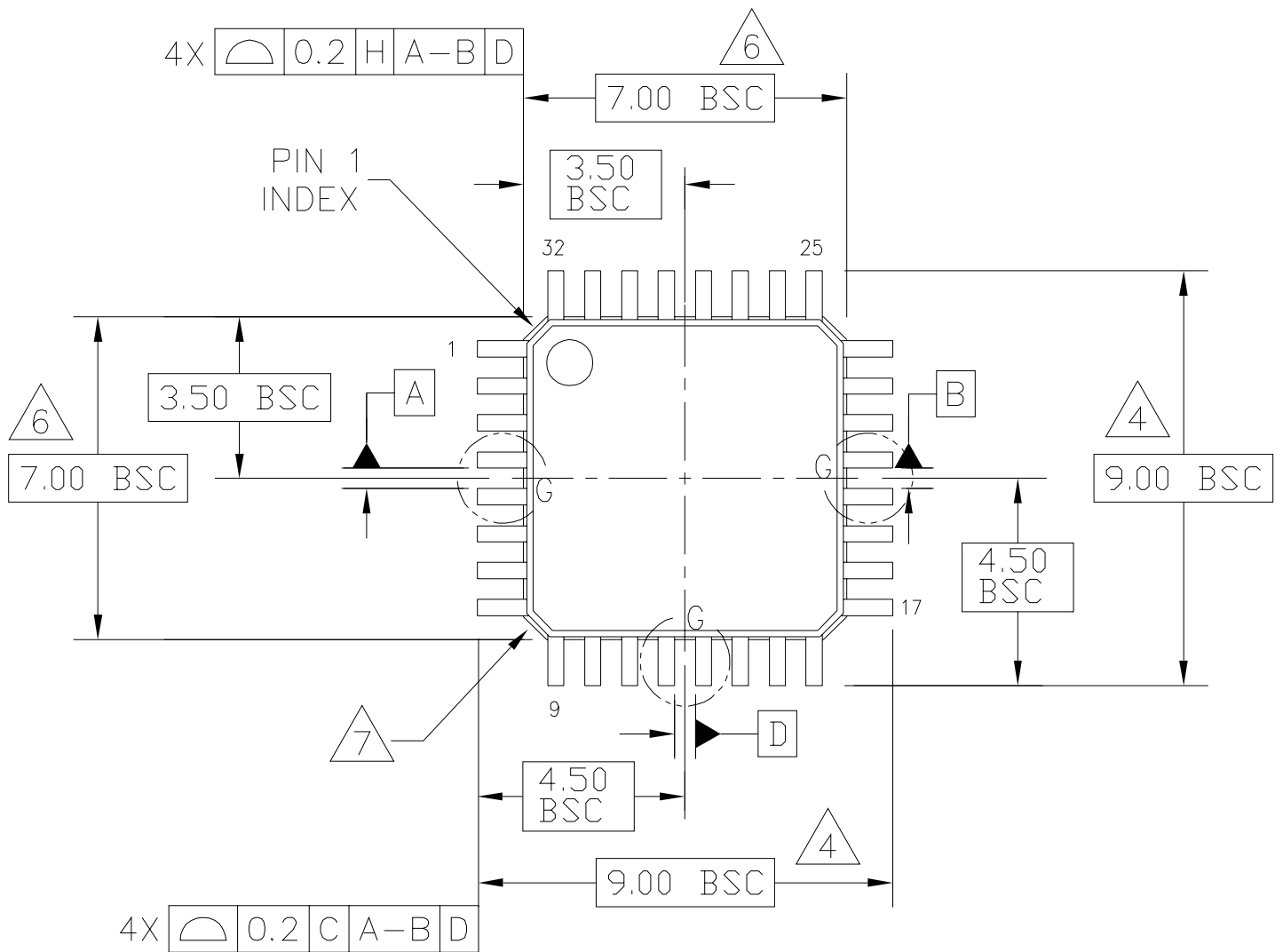
1. DIMENSIONING AND TOLERANCING PER ASME Y14.5M-1994.

2. ALL DIMENSIONS IN MILLIMETERS.

3. DIMENSION TO CENTER OF LEAD WHEN FORMED PARALLEL.

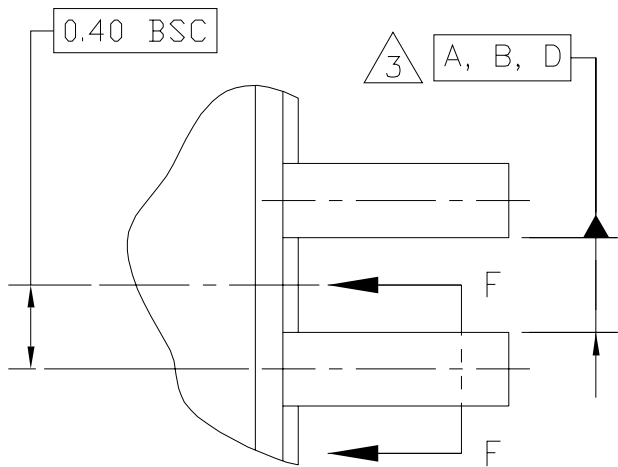
4. DIMENSION DOES NOT INCLUDE MOLD FLASH. MAXIMUM MOLD FLASH 0.25.

© FREESCALE SEMICONDUCTOR, INC. ALL RIGHTS RESERVED.	<b>MECHANICAL OUTLINE</b>	PRINT VERSION NOT TO SCALE	
TITLE:  42 LD PDIP	DOCUMENT NO: 98ASB42767B	REV: A	
	CASE NUMBER: 858-01	24 OCT 2005	
	STANDARD: NON JEDEC		

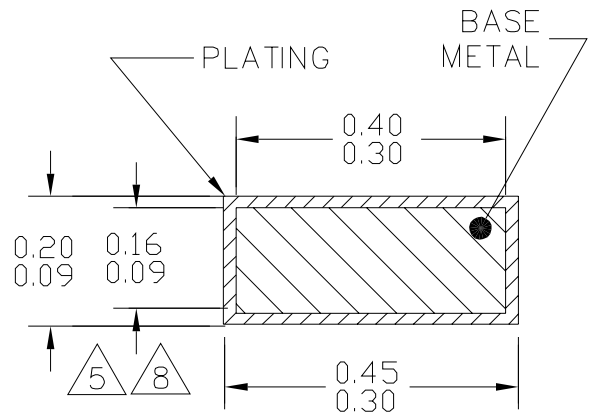


© FREESCALE SEMICONDUCTOR, INC. ALL RIGHTS RESERVED.	MECHANICAL OUTLINE	PRINT VERSION NOT TO SCALE	
TITLE:  LOW PROFILE QUAD FLAT PACK (LQFP) 32 LEAD, 0.8 PITCH (7 X 7 X 1.4)	DOCUMENT NO: 98ASH70029A	REV: C	
	CASE NUMBER: 873A-04	01 APR 2005	
	STANDARD: JEDEC MS-026 BBA		



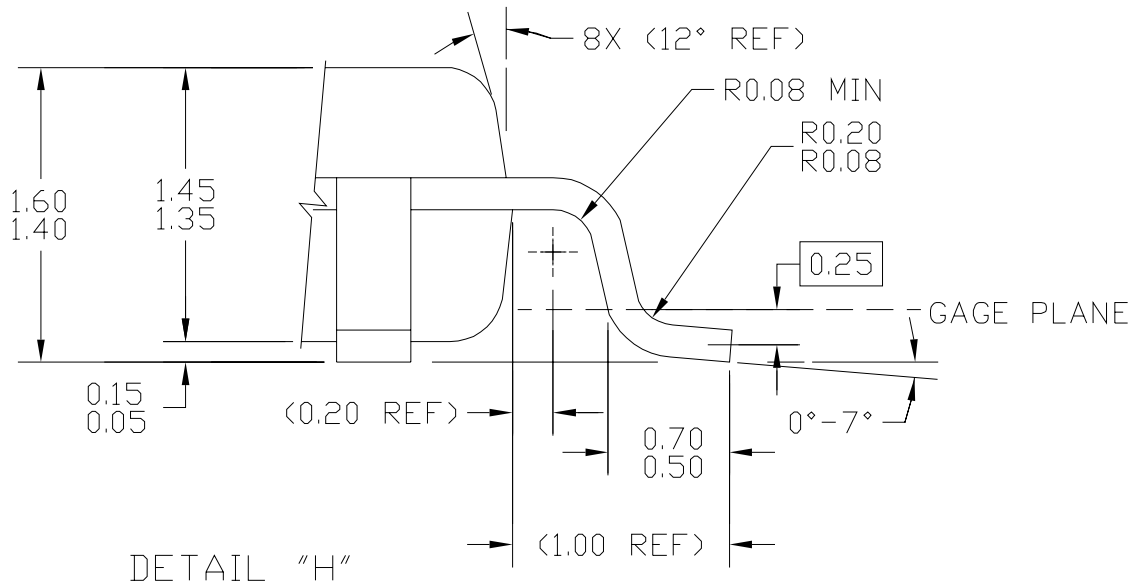


DETAIL G



⊕ 0.2 (M) C A-B D

SECTION F-F  
ROTATED 90°CW  
32 PLACES



DETAIL "H"

© FREESCALE SEMICONDUCTOR, INC. ALL RIGHTS RESERVED.	MECHANICAL OUTLINE	PRINT VERSION NOT TO SCALE	
TITLE: LOW PROFILE QUAD FLAT PACK (LQFP) 32 LEAD, 0.8 PITCH (7 X 7 X 1.4)	DOCUMENT NO: 98ASH70029A	REV: C	
	CASE NUMBER: 873A-04	01 APR 2005	
	STANDARD: JEDEC MS-026 BBA		

NOTES:

1. DIMENSIONS ARE IN MILLIMETERS.

2. INTERPRET DIMENSIONS AND TOLERANCES PER ASME Y14.5-1994.

3. DATUMS A, B, AND D TO BE DETERMINED AT DATUM PLANE H.

4. DIMENSIONS TO BE DETERMINED AT SEATING PLANE DATUM C.

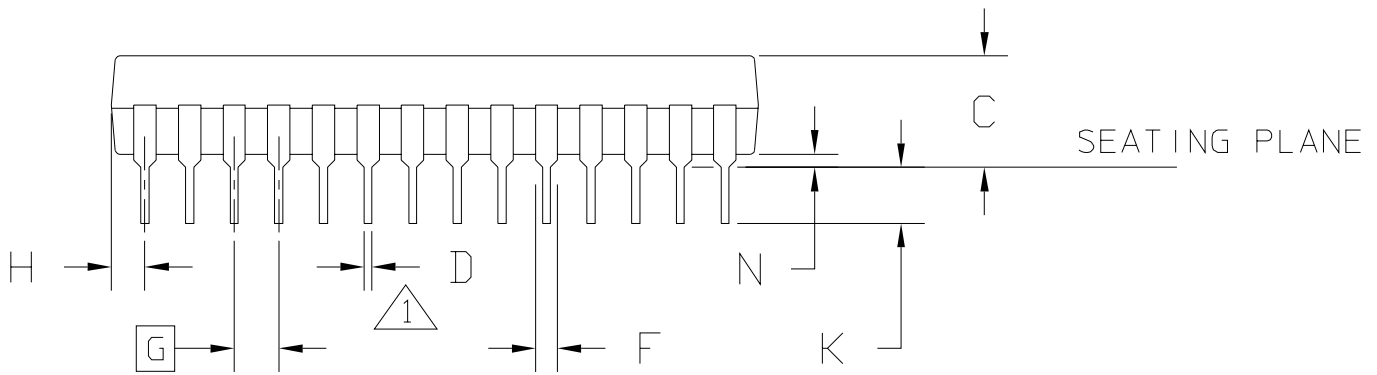
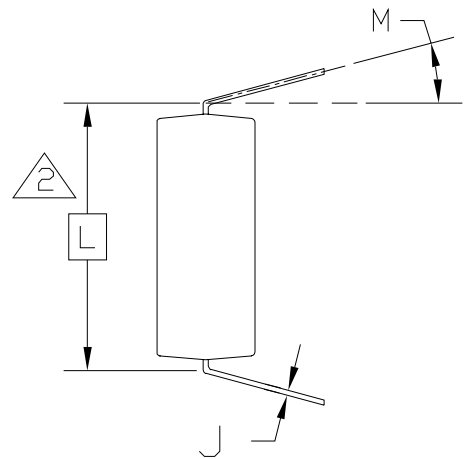
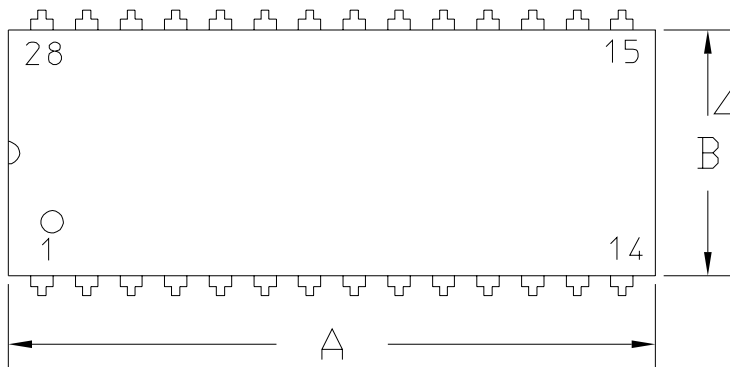
5. DIMENSION DOES NOT INCLUDE DAMBAR PROTRUSION. ALLOWABLE DAMBAR PROTRUSION SHALL NOT CAUSE THE LEAD WIDTH TO EXCEED THE MAXIMUM DIMENSION BY MORE THAN 0.08 MM. DAMBAR CANNOT BE LOCATED ON THE LOWER RADIUS OR THE FOOT. MINIMUM SPACE BETWEEN PROTRUSION AND ADJACENT LEAD OR PROTRUSION: 0.07 MM.

6. DIMENSIONS DO NOT INCLUDE MOLD PROTRUSION. ALLOWABLE PROTRUSION IS 0.25 MM PER SIDE. DIMENSIONS ARE MAXIMUM PLASTIC BODY SIZE DIMENSIONS INCLUDING MOLD MISMATCH.

7. EXACT SHAPE OF EACH CORNER IS OPTIONAL.

8. THESE DIMENSIONS APPLY TO THE FLAT SECTION OF THE LEAD BETWEEN 0.1 MM AND 0.25 MM FROM THE LEAD TIP.

© FREESCALE SEMICONDUCTOR, INC. ALL RIGHTS RESERVED.	MECHANICAL OUTLINE	PRINT VERSION NOT TO SCALE	
TITLE: LOW PROFILE QUAD FLAT PACK (LQFP) 32 LEAD, 0.8 PITCH (7 X 7 X 1.4)	DOCUMENT NO: 98ASH70029A	REV: C	
	CASE NUMBER: 873A-04	01 APR 2005	
	STANDARD: JEDEC MS-026 BBA		



© FREESCALE SEMICONDUCTOR, INC. ALL RIGHTS RESERVED.	MECHANICAL OUTLINE	PRINT VERSION NOT TO SCALE	
TITLE:  28 LD PDIP	DOCUMENT NO: 98ASB42390B	REV: D	
	CASE NUMBER: 710-02	24 MAY 2005	
	STANDARD: NON-JEDEC		

NOTES:

1. POSITIONAL TOLERANCE OF LEADS, SHALL BE WITHIN 0.25 MM (0.010) AT MAXIMUM MATERIAL CONDITION, IN RELATION TO SEATING PLANE AND EACH OTHER.

2. DIMENSION TO CENTER OF LEADS WHEN FORMED PARALLEL.

3. DIMENSION DOES NOT INCLUDE MOLD FLASH.

4. 710-01 OBSOLETE, NEW STD 710-02.

5. CONTROLLING DIMENSION: INCH

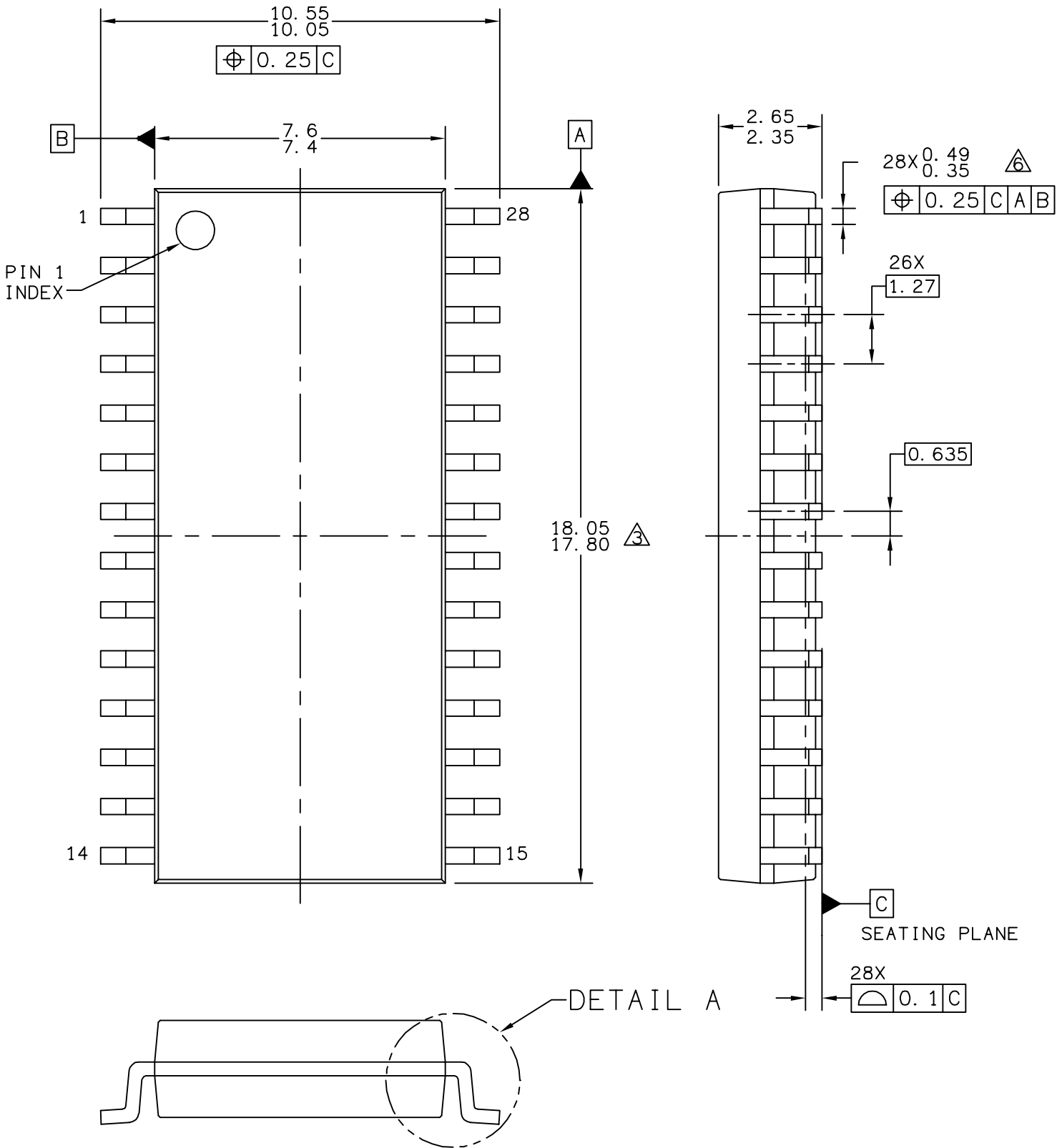
DIM	INCH		MILLIMETER		DIM	INCH		MILLIMETER	
	MIN	MAX	MIN	MAX		MIN	MAX	MIN	MAX
A	1.435	1.465	36.45	37.21					
B	0.540	0.560	13.72	14.22					
C	0.155	0.200	3.94	5.08					
D	0.014	0.022	0.36	0.56					
F	0.040	0.060	1.02	1.52					
G	0.100 BSC		2.54 BSC						
H	0.065	0.085	1.65	2.16					
J	0.008	0.015	0.20	0.38					
K	0.115	0.135	2.92	3.43					
L	0.600 BSC		15.24 BSC						
M	0°	15°	0°	15°					
N	0.020	0.040	0.51	1.02					

© FREESCALE SEMICONDUCTOR, INC.  
ALL RIGHTS RESERVED.

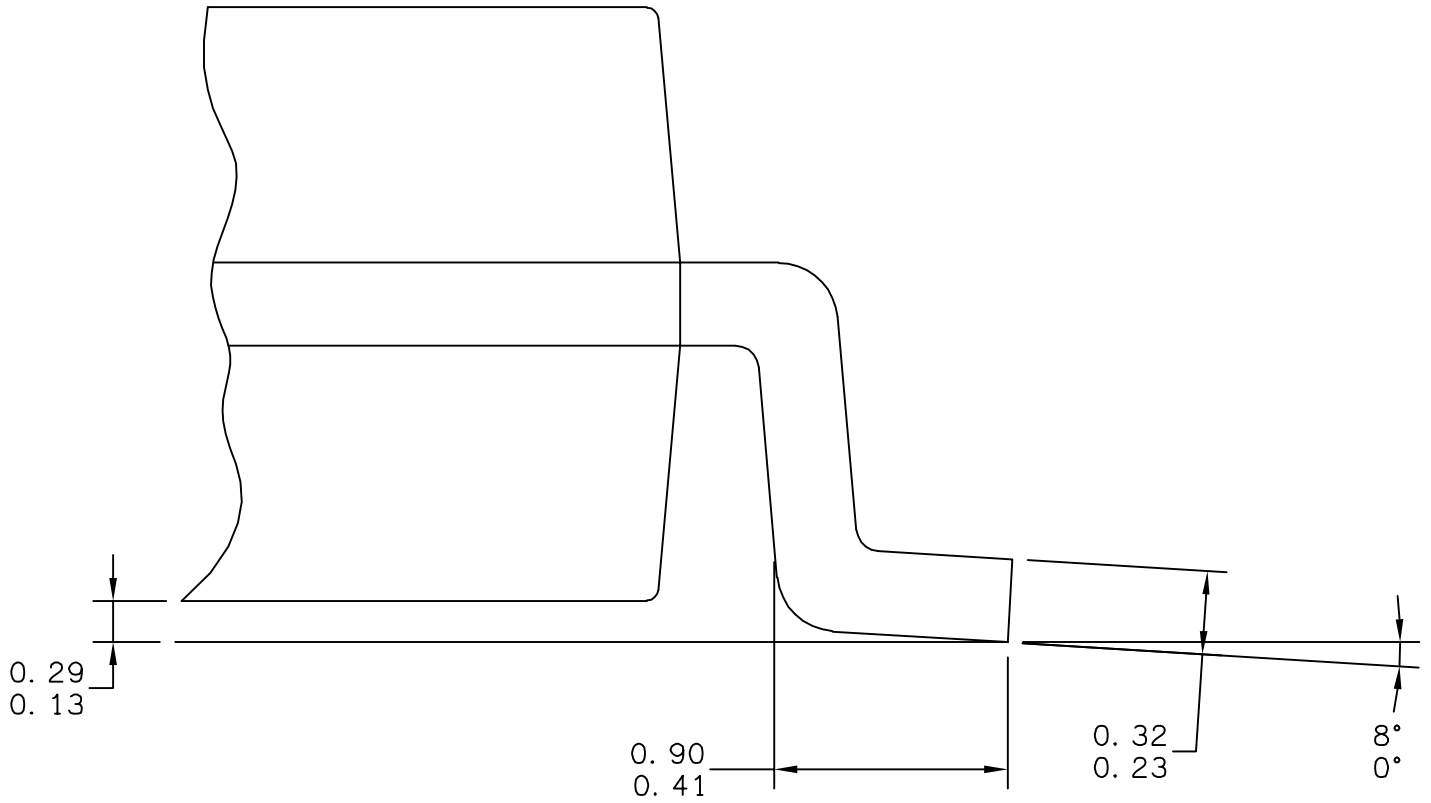
MECHANICAL OUTLINE

PRINT VERSION NOT TO SCALE

TITLE:  28 LD PDIP	DOCUMENT NO: 98ASB42390B	REV: D
	CASE NUMBER: 710-02	24 MAY 2005
	STANDARD: NON-JEDEC	



© FREESCALE SEMICONDUCTOR, INC. ALL RIGHTS RESERVED.	<b>MECHANICAL OUTLINE</b>	PRINT VERSION NOT TO SCALE	
TITLE: SOIC, WIDE BODY, 28 LEAD CASEOUTLINE	DOCUMENT NO: 98ASB42345B	REV: G	
	CASE NUMBER: 751F-05	10 MAR 2005	
	STANDARD: MS-013AE		



© FREESCALE SEMICONDUCTOR, INC.  
ALL RIGHTS RESERVED.

**MECHANICAL OUTLINE**

PRINT VERSION NOT TO SCALE

TITLE: SOIC, WIDE BODY,  
28 LEAD  
CASEOUTLINE

DOCUMENT NO: 98ASB42345B

REV: G

CASE NUMBER: 751F-05

10 MAR 2005

STANDARD: MS-013AE

NOTES:

1. DIMENSIONS ARE IN MILLIMETERS.

2. DIMENSIONING AND TOLERANCING PER ASME Y14.5M-1994.

3. THIS DIMENSION DOES NOT INCLUDE MOLD PROTRUSION. MAXIMUM MOLD PROTRUSION 0.15 PER SIDE.

4. 751F-01 THRU -04 OBSOLETE. NEW STANDARD: 751F-05

5. THIS DIMENSION DOES NOT INCLUDE DAM BAR PROTRUSION ALLOWABLE DAM BAR PROTRUSION SHALL BE 0.13 TOTAL IN EXCESS OF THIS DIMENSION AT MAXIMUM MATERIAL CONDITION.

© FREESCALE SEMICONDUCTOR, INC. ALL RIGHTS RESERVED.	<b>MECHANICAL OUTLINE</b>	PRINT VERSION NOT TO SCALE	
TITLE: SOIC, WIDE BODY, 28 LEAD CASEOUTLINE	DOCUMENT NO: 98ASB42345B	REV: G	
	CASE NUMBER: 751F-05	10 MAR 2005	
	STANDARD: MS-013AE		





# Chapter 25

## Ordering Information

### 25.1 Introduction

This section contains instructions for ordering the MC68HC908GR8 and MC68HC908GR4.

### 25.2 MC Order Numbers

**Table 25-1. MC Order Numbers**

	MC Order Number <sup>(1)</sup>	Operating Temperature Range (°C)
<b>Production Parts</b>	MC68HC908GR8CP	- 40 to + 85
	MC68HC908GR8CFA	- 40 to + 85
	MC68HC908GR8CDW	- 40 to + 85
	MC68HC908GR8VFA	- 40 to + 105
	MC68HC908GR8VP	- 40 to + 105
	MC68HC908GR8VDW	- 40 to + 105
	MC68HC908GR8MFA	- 40 to + 125
	MC68HC908GR8MP	- 40 to + 125
	MC68HC908GR8MDW	- 40 to + 125
	MC68HC908GR4CP	- 40 to + 85
	MC68HC908GR4CFA	- 40 to + 85
	MC68HC908GR4CDW	- 40 to + 85
	MC68HC908GR4VFA	- 40 to + 105
	MC68HC908GR4VP	- 40 to + 105
	MC68HC908GR4VDW	- 40 to + 105
	MC68HC908GR4MFA	- 40 to + 125
	MC68HC908GR4MP	- 40 to + 125
	MC68HC908GR4MDW	- 40 to + 125
<b>Tape and Reel</b>	MC908GR8CFAR2	- 40 to + 85
	MC908GR8CDWR2	- 40 to + 85
	MC908GR8VFAR2	- 40 to + 105
	MC908GR8VDWR2	- 40 to + 105
	MC908GR8MFAR2	- 40 to + 125
	MC908GR8MDWR2	- 40 to + 125
	MC908GR4CFAR2	- 40 to + 85
	MC908GR4CDWR2	- 40 to + 85
	MC908GR4VFAR2	- 40 to + 105
	MC908GR4VDWR2	- 40 to + 105
	MC908GR4MFAR2	- 40 to + 125
	MC908GR4MDWR2	- 40 to + 125

- 1. FA = quad flat pack
- P = plastic dual in line package
- DW = Small outline integrated circuit (SOIC) package

## 25.3 Development Tools

**Table 25-2. Development Tool Kits**

Ordering Part Number	Description
M68ICS08GR	HC908GR8 ICS KIT includes: M68ICS08GR programmer board, Windows-based IDE, 68HC908GR8 sample, ICS Board & IDE documentation, Universal Power Supply, Serial cable
KITMMEVS08GR	HC908GR8 EVS KIT includes: M68MMPFB0508, M68EML08GP32, M68CBL05C, M68TC08GR8P28, M68TC08GR8FA32, M68TQS032SAG1, M68TQP032SA1, M68ICS08GR Kit
KITMMDS08GR	HC908GR8 MMDS KIT includes: M68MMDS0508, M68EML08GP32, M68CBL05C, M68TC08GR8P28, M68TC08GR8FA32, M68TQS032SAG1, M68TQP032SA1, M68ICS08GR Kit

**Table 25-3. Development Tool Components**

Ordering Part Number	Description	Comments
M68MMDS0508	High performance emulator	
M68MMPFB0508	MMEVS Platform Board	
M68EML08GP32	HC908GP32 Emulator Board	Used for HC908GR8/GR4 emulation
M68CBL05C	Low noise flex-cable	
M68TC08GR8P28	28-pin DIP target head adapter	
M68TC08GR8FA32	32-pin QFP target head adapter	
M68TQS032SAG1	32-pin TQ socket with guides	
M68TQP032SA1	32-pin TQPACK	

## Revision History

### Changes from Rev 6.0 published in April 2006 to Rev 7.0 published in October 2006

Section	Page (in Rev 6.0)	Description of change
<a href="#">Mechanical Specifications</a>	272	Corrected cas outline for 32-pin LQFP.

### Changes from Rev 5.0 published in August 2005 to Rev 6.0 published in April 2006

Section	Page (in Rev 6.0)	Description of change
General Description	20	Added 42-pin SDIP to standard feature list.
	22	Added pin assignment drawing for the 42-pin SDIP.
Low-Power Modes	38	Updated description of clock generator module in stop mode to remove erroneous information.
Electrical Specifications	255	Updated to reflect correct values.
	249	Added DC injection current and input hysteresis values to:
	251	5.0 V DC Electrical Characteristics 3.0 V DC Electrical Characteristics
Mechanical Specifications	270	Added case outline drawing for the 42-pin SDIP.

### Changes from Rev 4.0 published in February 2002 to Rev 5.0 published in August 2005

Section	Page (in Rev 5.0)	Description of change	
Memory Map	27	In 4th, 5th and 6th bullets	Address of Interrupt Status Register 1 (INT1) corrected to \$FE04 Address of Interrupt Status Register 2 (INT2) corrected to \$FE05 Address of Interrupt Status Register 3 (INT3) corrected to \$FE06
	28	Near bottom of memory map	
	35	In bottom two registers	
	35	In top register	
System Integration Module (SIM)	185	In last three registers	
Throughout		Updated to meet Freescale Identity guidelines.	

## Changes from Rev 3.0 published in February 2002 to Rev 4.0 published in June 2002

Section	Page (in Rev 4.0)	Description of change
All references to the ROM MC68HC08GR8 removed. Appendix A removed.		
Electrical Specifications	363	Maximum junction temperature increased to 140°C
	364	Input High Voltage for OSC1 changed Stop I <sub>DD</sub> for temperatures >85°C added
	366	Input High Voltage for OSC1 changed Input Low Voltage for OSC1 changed Stop I <sub>DD</sub> for temperatures >85°C added

## Changes from Rev 2.0 published in January 2002 to Rev 3.0 published in February 2002

Section	Page (in Rev 3.0)	Description of change
All references to the ROM MC68HC08GR8 removed. Appendix A removed.		
Electrical Specifications	363	Maximum operating temperature increased to 125°C
	376-377	Maximum temperature increased to 125°C in titles of figures 23-13, 23-14 and 23-15
	383	Maximum operating temperature increased to 125°C
Ordering Information	391	New section added

## Changes from Rev 1.0 published in April 2001 to Rev 2.0 published in December 2001

Section	Page (in Rev 2.0)	Description of change
Monitor ROM (MON)	The blank state of the reset vectors, \$FFFE and \$FFFF, was incorrectly defined as \$00 and is now \$FF. This affects several places in the Monitor ROM (MON) section. The information was previously described in an addendum. See details below:	
	190	Penultimate bullet of features list
	192	Final sentence of first paragraph Each list item in Entering Monitor Mode section
	193	Third column of Table 15-1
Timebase Module (TBM)	329	Several changes for clarification
Timer Interface Module (TIM)	335	Several changes for clarification
Electrical Specifications	385	Typical column added to table. Typical values added for FLASH row program endurance and FLASH data retention time



## How to Reach Us:

### Home Page:

[www.freescale.com](http://www.freescale.com)

### E-mail:

[support@freescale.com](mailto:support@freescale.com)

### USA/Europe or Locations Not Listed:

Freescale Semiconductor  
Technical Information Center, CH370  
1300 N. Alma School Road  
Chandler, Arizona 85224  
+1-800-521-6274 or +1-480-768-2130  
[support@freescale.com](mailto:support@freescale.com)

### Europe, Middle East, and Africa:

Freescale Halbleiter Deutschland GmbH  
Technical Information Center  
Schatzbogen 7  
81829 Muenchen, Germany  
+44 1296 380 456 (English)  
+46 8 52200080 (English)  
+49 89 92103 559 (German)  
+33 1 69 35 48 48 (French)  
[support@freescale.com](mailto:support@freescale.com)

### Japan:

Freescale Semiconductor Japan Ltd.  
Headquarters  
ARCO Tower 15F  
1-8-1, Shimo-Meguro, Meguro-ku,  
Tokyo 153-0064  
Japan  
0120 191014 or +81 3 5437 9125  
[support.japan@freescale.com](mailto:support.japan@freescale.com)

### Asia/Pacific:

Freescale Semiconductor Hong Kong Ltd.  
Technical Information Center  
2 Dai King Street  
Tai Po Industrial Estate  
Tai Po, N.T., Hong Kong  
+800 2666 8080  
[support.asia@freescale.com](mailto:support.asia@freescale.com)

### For Literature Requests Only:

Freescale Semiconductor Literature Distribution Center  
P.O. Box 5405  
Denver, Colorado 80217  
1-800-441-2447 or 303-675-2140  
Fax: 303-675-2150  
[LDCForFreescaleSemiconductor@hibbertgroup.com](mailto:LDCForFreescaleSemiconductor@hibbertgroup.com)

RoHS-compliant and/or Pb-free versions of Freescale products have the functionality and electrical characteristics of their non-RoHS-compliant and/or non-Pb-free counterparts. For further information, see <http://www.freescale.com> or contact your Freescale sales representative.

For information on Freescale's Environmental Products program, go to <http://www.freescale.com/epp>.

Information in this document is provided solely to enable system and software implementers to use Freescale Semiconductor products. There are no express or implied copyright licenses granted hereunder to design or fabricate any integrated circuits or integrated circuits based on the information in this document.

Freescale Semiconductor reserves the right to make changes without further notice to any products herein. Freescale Semiconductor makes no warranty, representation or guarantee regarding the suitability of its products for any particular purpose, nor does Freescale Semiconductor assume any liability arising out of the application or use of any product or circuit, and specifically disclaims any and all liability, including without limitation consequential or incidental damages. "Typical" parameters that may be provided in Freescale Semiconductor data sheets and/or specifications can and do vary in different applications and actual performance may vary over time. All operating parameters, including "Typicals", must be validated for each customer application by customer's technical experts. Freescale Semiconductor does not convey any license under its patent rights nor the rights of others. Freescale Semiconductor products are not designed, intended, or authorized for use as components in systems intended for surgical implant into the body, or other applications intended to support or sustain life, or for any other application in which the failure of the Freescale Semiconductor product could create a situation where personal injury or death may occur. Should Buyer purchase or use Freescale Semiconductor products for any such unintended or unauthorized application, Buyer shall indemnify and hold Freescale Semiconductor and its officers, employees, subsidiaries, affiliates, and distributors harmless against all claims, costs, damages, and expenses, and reasonable attorney fees arising out of, directly or indirectly, any claim of personal injury or death associated with such unintended or unauthorized use, even if such claim alleges that Freescale Semiconductor was negligent regarding the design or manufacture of the part.

Freescale™ and the Freescale logo are trademarks of Freescale Semiconductor, Inc. All other product or service names are the property of their respective owners.

© Freescale Semiconductor, Inc. 2006. All rights reserved.