

# AS85049/26-1 and MS3419 Straight Crimp Ring Backshell and Crimp Ring



AS85049

CONNECTOR DESIGNATOR:	
<b>A</b>	AS50151 Series AS34001
	MIL-DTL-26482 Series II
	AS81703 Series III
	MIL-DTL-83723 Series I & III

**Basic Part Number**  
**M85049/26-1** = Adapter Only  
**M85049/26-2** = Crimp Ring Only  
**M85049/26-3** = Adapter with Crimp Ring  
 (See Page B-52 for Crimp Ring)

**Shell Size**  
 (Table II)

**M85049/26-1 - 12 W**

**Superseded Part Number**

**MS3419-21 C**

Basic Part No.	Shell Size
----------------	------------

**Finish**  
 (Material is Aluminum Only)  
**A** = Electroless Nickel  
**C** = 500 Hr. Cadmium Olive Drab over Electroless Nickel

**B**

**Finish**  
**N** = Electroless Nickel  
**W** = 1,000 Hr. Cadmium Olive Drab over Electroless Nickel  
**X** = Aluminum, Nickel Fluorocarbon Polymer  
**Z** = Aluminum, Zinc-Nickel, Black

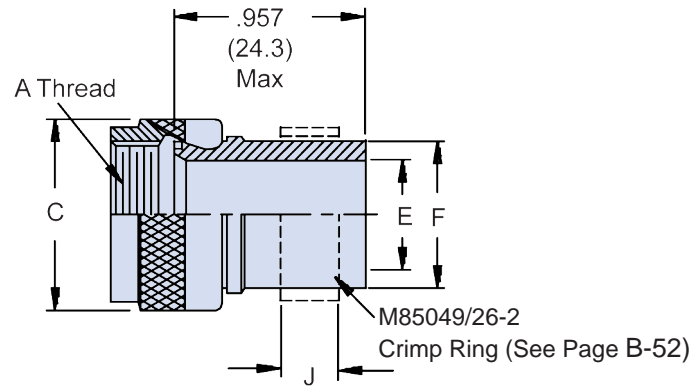

TABLE I: Adapter Shell Size, Thread, and Dimensions				
Shell Size	A Thread Class 2B	C Dia Max	E Dia	F Dia
3	.562 - 24 UNEF	.670 (17.0)	.250 (6.4)	.337 (8.6)
8	.500 - 20 UNF	.620 (15.7)	.250 (6.4)	.337 (8.6)
10	.625 - 24 UNEF	.730 (18.5)	.325 (8.3)	.488 (12.4)
12	.750 - 20 UNEF	.860 (21.8)	.420 (10.7)	.500 (12.7)
14	.875 - 20 UNEF	.980 (24.9)	.540 (13.7)	.620 (15.7)
16	1.000 - 20 UNEF	1.110 (28.2)	.670 (17.0)	.750 (19.1)
18	1.062 - 18 UNEF	1.220 (31.0)	.789 (20.0)	.880 (22.4)
20	1.188 - 18 UNEF	1.350 (34.3)	.914 (23.2)	1.000 (25.4)
22	1.313 - 18 UNEF	1.470 (37.3)	1.039 (26.4)	1.120 (28.4)
24	1.438 - 18 UNEF	1.590 (40.4)	1.112 (28.2)	1.192 (30.3)
28	1.750 - 18 UNS	1.970 (50.0)	1.389 (35.3)	1.545 (39.2)
32	2.000 - 18 UNS	2.220 (56.4)	1.635 (41.5)	1.795 (45.6)
36	2.250 - 16 UN	2.470 (62.7)	1.850 (47.0)	2.045 (51.9)
40	2.500 - 16 UN	2.720 (69.1)	2.065 (52.5)	2.295 (58.3)
44	2.750 - 16 UN	2.970 (75.4)	2.320 (58.9)	2.545 (64.6)
48	3.000 - 16 UN	3.220 (81.8)	2.570 (65.3)	2.795 (71.0)
61	1.500 - 18 UNEF	1.650 (41.9)	1.210 (30.7)	1.359 (34.5)

- APPLICATION NOTES**
- For complete dimensions see the applicable Military Specification.
  - Metric dimensions (mm) are in parentheses.

See Page B-52 for AS85049/26-2 Crimp Ring

Dimensions in inches (millimeters) and are subject to change without notice.