

Lamp-Base Thread EMI/RFI Shrink Boot Adapter with Strain Relief and Optional Shrink Boot Rotatable Coupling - Low Profile

CONNECTOR DESIGNATOR:

A	MIL-DTL-5015, -26482, Series II and -83723 Series I and III
F	MIL-DTL-38999 Series I, II
H	MIL-DTL-38999 Series III and IV
J	MIL-DTL-81511 Series I, II, III & IV
L	LN29729
S	PATT 105, PATT 603, PATT 608

ROTATABLE COUPLING

Finish

B = Cadmium Plate, Olive Drab
C = Anodize, Black
G = Hard Coat, Anodic
M = Electroless Nickel
NF = Cadmium Plate, Olive Drab over Electroless Nickel
 (See Page H-3)

Angle and Profile*

H = 45°
J = 90°
S = Straight

Shrink Boot

See Table IV
 (Omit for None)

311

F

H

001

M

16

03

E

T

Product Series

Connector Designator

Basic Part Number

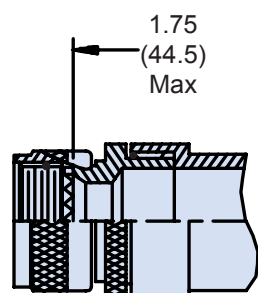
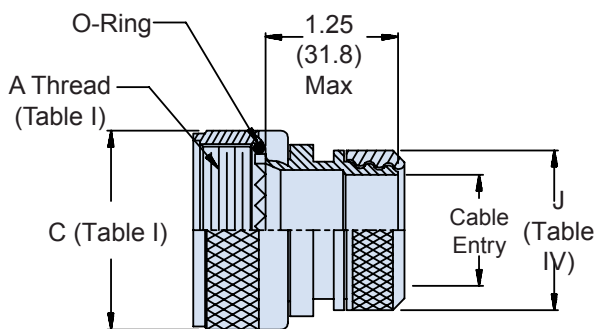
Shell Size
See Table IIICable Entry
See Table IVStrain Relief
(Omit for Nut)STYLE 2
STRAIGHT

Straight - S

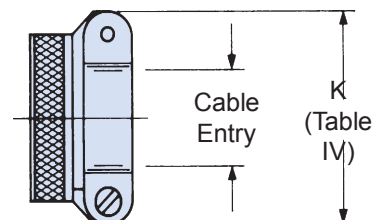
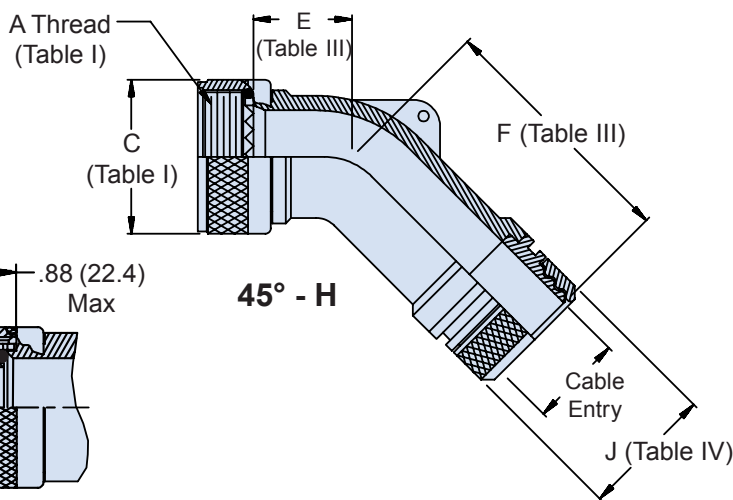

Add "T" to Part Number
 for Standard Boot

STYLE E
STRAIN RELIEF

45° - H

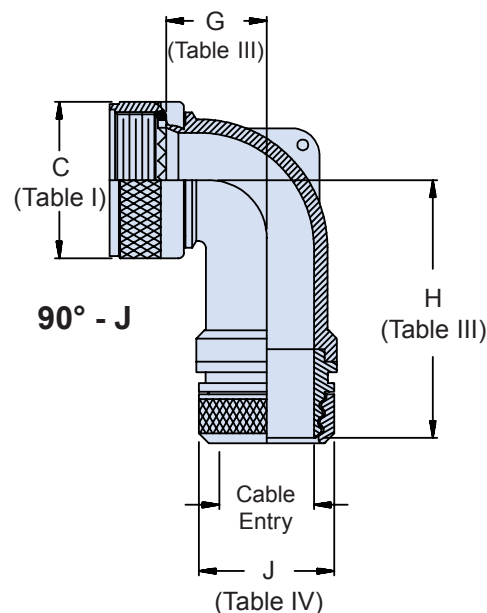

90° - J

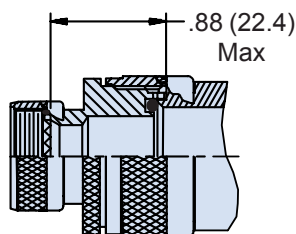
STYLE 2
45° & 90°

Dimensions in inches (millimeters) and are subject to change without notice.

CAGE Code 06324

Printed in U.S.A.

Lamp-Base Thread EMI/RFI Shrink Boot Adapter with Strain Relief and Optional Shrink Boot Rotatable Coupling - Low Profile



See Pages H-2 and H-3 for unabridged Tables I and II, and Pages H-4 and H-5 for MIL-DTL-5015

TABLE III: Connector Designators and Dimensions

Shell Size - Conn. Desig. A-F-J-L-S	H	E Max	F Max	G Max	H Max
08	09	.457 (11.6)	1.630 (41.4)	.500 (12.7)	1.640 (41.7)
10	11	.520 (13.2)	1.690 (42.9)	.595 (15.1)	1.760 (44.7)
12	13	.582 (14.8)	1.750 (44.5)	.610 (15.5)	1.780 (45.2)
14	15	.645 (16.4)	1.840 (46.7)	.700 (17.8)	1.850 (47.0)
16	17	.738 (18.7)	1.950 (49.5)	.885 (22.5)	1.940 (49.3)
18	19	.926 (23.5)	2.140 (54.4)	.975 (24.8)	2.110 (53.6)
20	21	.926 (23.5)	2.140 (54.4)	.975 (24.8)	2.110 (53.6)
22	23	1.020 (25.9)	2.290 (58.2)	1.125 (28.6)	2.220 (56.4)
24	25	1.020 (25.9)	2.290 (58.2)	1.125 (28.6)	2.220 (56.4)
28		1.145 (29.1)	2.340 (59.4)	1.225 (31.1)	2.390 (60.7)
32		1.207 (30.7)	2.440 (62.0)	1.575 (40.0)	2.640 (67.1)
36		1.238 (31.4)	2.530 (64.3)	1.775 (45.1)	2.640 (67.1)

TABLE IV: Cable Entry, Dimensions and Shrink Boot

Dash No.	J Max	K Max	Cable Entry Max	Shrink Boot Part Number
01	.448 (11.4)	.781 (19.8)	.125 (3.2)	n/a
02	.515 (13.1)	.968 (24.6)	.250 (6.4)	770-001S103
03	.640 (16.3)	1.046 (26.6)	.375 (9.5)	770-001S103
04	.765 (19.4)	1.156 (29.4)	.500 (12.7)	770-001S104
05	.920 (23.4)	1.219 (31.0)	.625 (15.9)	770-001S104
06	1.015 (25.8)	1.343 (34.1)	.750 (19.1)	770-001S105
07	1.140 (29.0)	1.469 (37.3)	.875 (22.2)	770-001S106
08	1.265 (32.1)	1.594 (40.5)	1.000 (25.4)	770-001S106
09	1.432 (36.4)	1.719 (43.7)	1.125 (28.6)	770-001S107
10	1.515 (38.5)	1.844 (46.8)	1.250 (31.8)	770-001S107
11	1.640 (41.7)	n/a	1.375 (34.9)	770-001S108
12	1.765 (44.8)	n/a	1.500 (38.1)	770-001S108
13	2.015 (51.2)	n/a	1.750 (44.5)	770-001S108

APPLICATION NOTES

1. Cable Entry is defined as the accommodation range for the wire bundle or cable. Dimensions shown are not intended for inspection criteria.
2. See Backshell Interface Dimensions and Standards on Pages H-4 and H-5.
3. When maximum entry is exceeded, Style 2 will be supplied and dimensions E, F, G and H will not apply. Please consult factory.

Dimensions in inches (millimeters) and are subject to change without notice.

CAGE Code 06324

Printed in U.S.A.

© 2011 Glenair, Inc.

GLENAIR, INC. • 1211 AIR WAY • GLENDALE, CA 91201-2497 • 818-247-6000 • FAX 818-500-9912

www.glenair.com

H-11

E-Mail: sales@glenair.com