

930-008 Gasket for Series 800 & 801 Flange Mount Receptacle Connector

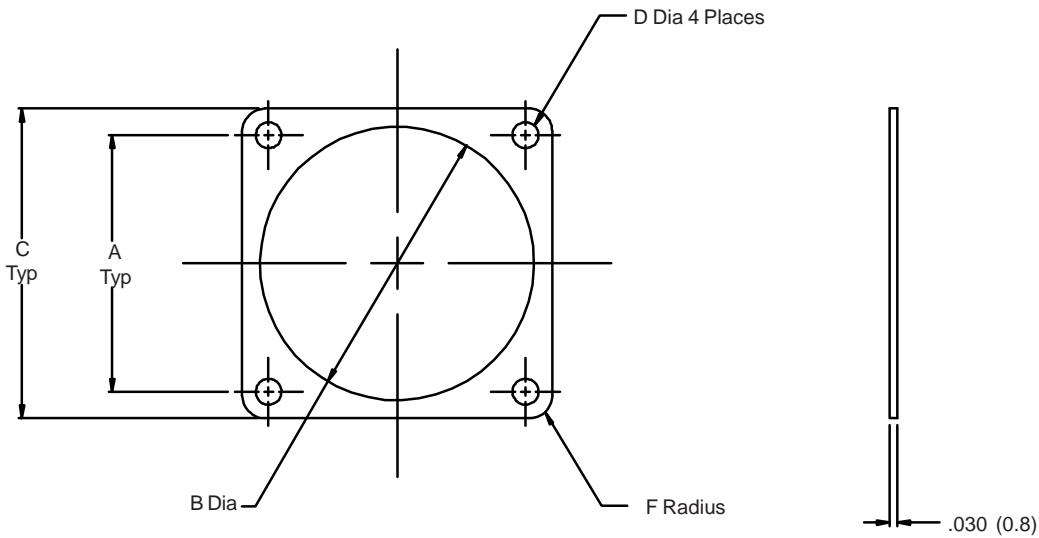
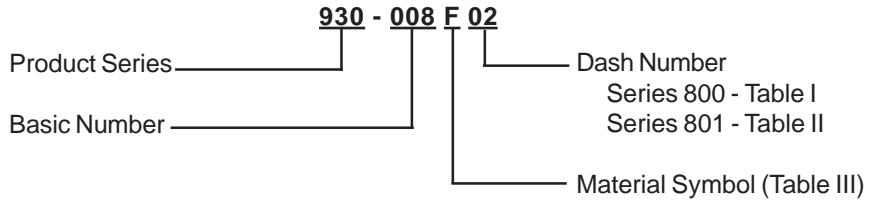

NOTES:

1. Identified by bag and tag, 25 pieces maximum per bag.
2. Metric dimensions (mm) are indicated in parentheses.

930-008
Gasket for Series 800 & 801 Flange Mount
Receptacle Connector



Miscellaneous
 Accessories

TABLE I: SERIES 800

| Dash No. | Series 800 Shell Size | A | | B Dia | | C | | D Dia | | F Rad | |
|----------|-----------------------|-------|--------|-------|--------|-------|--------|-------|-------|-------|-------|
| | | ±.005 | (0.1) | ±.007 | (0.2) | ±.008 | (0.2) | ±.005 | (0.1) | ±.015 | (0.4) |
| 01 | 5 | .363 | (9.2) | .290 | (7.4) | .527 | (13.4) | .093 | (2.4) | .078 | (2.0) |
| 02 | 6 | .423 | (10.7) | .350 | (8.9) | .588 | (14.9) | .093 | (2.4) | .078 | (2.0) |
| 03 | 7 | .483 | (12.3) | .460 | (11.7) | .650 | (16.5) | .125 | (3.2) | .078 | (2.0) |
| 04 | 8 | .550 | (14.0) | .530 | (13.5) | .715 | (18.2) | .125 | (3.2) | .078 | (2.0) |
| 05 | 9 | .719 | (18.3) | .593 | (15.1) | .938 | (23.8) | .125 | (3.2) | .105 | (2.7) |
| 06 | 12 | .812 | (20.6) | .718 | (18.2) | 1.031 | (26.2) | .125 | (3.2) | .105 | (2.7) |
| 07 | 14 | .906 | (23.0) | .968 | (24.6) | 1.125 | (28.6) | .125 | (3.2) | .105 | (2.7) |
| 08 | 15 | .969 | (24.6) | .968 | (24.6) | 1.219 | (31.0) | .125 | (3.2) | .105 | (2.7) |

TABLE I: SERIES 801

| Dash No. | Series 801 Shell Size | A | | B Dia | | C | | D Dia | | F Rad | |
|----------|-----------------------|-------|--------|-------|--------|-------|--------|-------|-------|-------|-------|
| | | ±.005 | (0.1) | ±.007 | (0.2) | ±.008 | (0.2) | ±.005 | (0.1) | ±.015 | (0.4) |
| 11 | 5 | .363 | (9.2) | .320 | (8.1) | .530 | (13.5) | .093 | (2.4) | .078 | (2.0) |
| 12 | 6 | .423 | (10.7) | .375 | (9.5) | .590 | (15.0) | .093 | (2.4) | .078 | (2.0) |
| 13 | 7 | .483 | (12.3) | .460 | (11.7) | .650 | (16.5) | .093 | (2.4) | .078 | (2.0) |
| 14 | - | - | - | - | - | - | - | - | - | - | - |
| 15 | 9 | .607 | (15.4) | .560 | (14.2) | .850 | (21.6) | .125 | (3.2) | .105 | (2.7) |
| 16 | 13 | .812 | (20.6) | .815 | (20.7) | 1.030 | (26.2) | .125 | (3.2) | .105 | (2.7) |
| 17 | 16 | .981 | (24.9) | 1.010 | (25.7) | 1.219 | (31.0) | .125 | (3.2) | .105 | (2.7) |
| 18 | 17 | 1.060 | (26.9) | 1.070 | (27.2) | 1.280 | (32.5) | .125 | (3.2) | .105 | (2.7) |

TABLE III: MATERIAL

| Symbol | Material Description | Color |
|----------|-------------------------|-----------|
| C | Conductive — Metex | Off-White |
| F | Fluorosilicone | Blue |
| M | Conductive — Con-Sil II | Black |
| N | Neoprene | Black |
| S | Silicone | Red |
| V | Viton | Black |

Metric Dimensions (mm) are indicated in parenthesis.