

METAL SHELL SCOOP-PROOF PLUG COVER

How To Order Receptacle Cover					
Sample Part Number	290-016	S	18	03-	6
Series - Shell Style	290-016 = Scoop Proof				
Attachment Type	See Table III				
Shell Size	See Table I				
Dash No.	See Table II, IV, V or VI, omit for Type SK				
Attachment Length	In Inches; ± .25 for Rope, ± Link for Chain				

Notes:

1. Assembly identified with manufacturer's name and P/N, space permitting.
2. Max. diameter mandrel over which assembled ring will rotate freely.
3. If retaining ring is desired, use Tables IV & V (solid) or Table VI (split ring).
4. For terminal lug or type "WS"; use Table II.
5. Material/finish:
Cover, attachment, clevis, hardware - CRES/passivate
O-ring - nitrile/n.a.

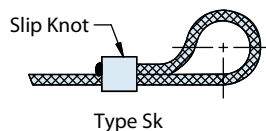
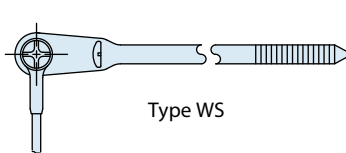
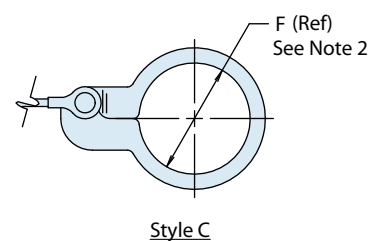
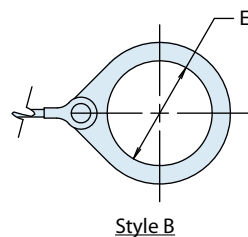
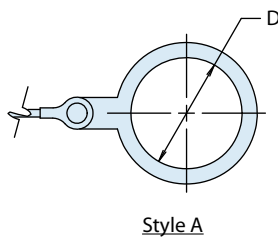
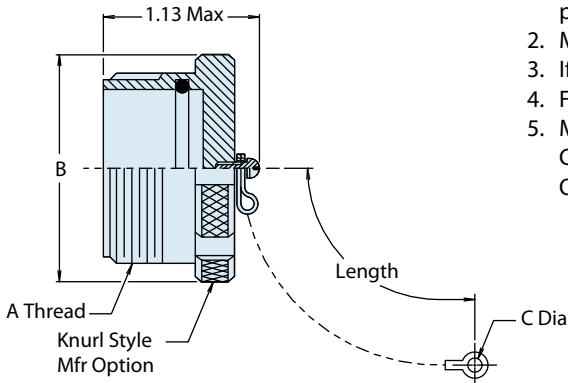

290-016

Metal Plug Protective Covers for Scoop-Proof Series 22 Connectors



Table I: Dimensions

Dash No	A Thread Class 2A	B Max
10	0.750 -.1P-.1L	0.900 (22.9)
12	0.875 -.1P-.1L	1.025 (26.0)
14	1.000 -.1P-.1L	1.150 (29.2)
16	1.125 -.1P-.1L	1.275 (32.4)
18	1.250 -.1P-.1L	1.525 (38.7)
20	1.375 -.1P-.1L	1.650 (41.9)
22	1.500 -.1P-.1L	1.775 (45.1)
24	1.625 -.1P-.1L	1.900 (48.3)

Table II: Split Ring Dimensions

Dash No.	C Dia.	
01	0.125	(3.2)
02	0.140	(3.6)
03	0.167	(4.2)
04	0.182	(4.6)
05	0.191	(4.9)
06	0.197	(5.0)
WS	With Strap	

Table III: Attachment Type

Sym	Attachment
B	Bead chain, brass, nickel plated, with terminal
C	Link chain, brass, nickel plated, with clevis terminal
D	Bead chain, CRES, passivated, with terminal
E	Link chain, CRES, passivated, with clevis terminal
F	Wire rope, nylon jacket w/ terminal
H	Wire rope, Fluoropolymer jacket w/terminal
K	Nylon rope
N	Attachment omitted
R	Wire rope, PVC jacket w/terminal
T	Wire rope, no jacket, w/terminal
S	#8 Sash chain, CRES, passivated
SK	Nylon rope, (black) with slip knot
U	Wire rope, polyurethane jacket with terminal

Table IV: Style A Solid Ring Dimensions

Dash No	D Dia ±.015	
095	0.312	(7.9)
100	0.391	(9.9)
101	0.516	(13.1)
102	0.583	(14.8)
103	0.641	(16.3)
104	0.708	(18.0)
105	0.766	(19.5)
205	0.788	(20.0)
106	0.896	(22.8)
206	0.907	(23.0)
107	1.016	(25.8)
207	1.025	(26.0)
108	1.141	(29.0)
308	1.188	(30.2)
208	1.203	(30.6)
109	1.266	(32.2)
209	1.312	(33.3)
110	1.391	(35.3)
210	1.438	(36.5)
111	1.521	(38.6)
211	1.536	(39.0)
112	1.641	(41.7)
113	1.766	(44.9)
213	1.812	(46.0)
114	1.891	(48.0)
214	1.938	(49.2)
115	2.078	(52.8)
116	2.406	(61.1)
117	2.510	(63.8)

Table V: Style B Solid Ring Dimensions

Dash No	E Dia ±.015	
08	0.468	(11.9)
10	0.593	(15.1)
12	0.718	(18.2)
13	0.765	(19.4)
14	0.844	(21.4)
15	0.890	(22.6)
16	0.968	(24.6)
17	1.015	(25.8)
18	1.093	(27.8)
19	1.140	(29.0)
20	1.203	(30.6)
21	1.265	(32.1)
22	1.343	(34.1)
23	1.453	(36.9)
24	1.484	(37.7)
25	1.577	(40.1)
27	1.640	(41.7)
28	1.687	(42.8)
29	1.765	(44.8)
30	1.890	(48.0)
31	1.953	(49.6)
32	1.968	(50.0)
33	2.077	(52.8)
35	2.140	(54.4)
36	2.187	(55.5)
40	2.406	(61.1)
44	2.656	(67.5)
48	3.031	(77.0)

Table VI: Style C Ring Dimensions

Dash No	F Dia	
50	0.425	(10.8)
52	0.485	(12.3)
54	0.640	(16.3)
56	0.750	(19.1)
58	0.890	(22.6)
60	1.015	(25.8)
62	1.095	(27.8)
64	1.130	(28.7)
66	1.250	(31.8)
68	1.350	(34.3)
70	1.375	(34.9)
72	1.485	(37.7)
74	1.625	(41.3)
76	1.750	(44.5)
78	1.875	(47.6)
80	1.980	(50.3)
82	2.060	(52.3)
84	2.235	(56.8)
86	2.310	(58.7)
88	2.475	(62.9)
90	2.655	(67.4)
92	2.810	(71.4)
94	3.045	(77.3)