

M24758/7-04-B-A

Basic Part No. _____
 Conduit Size Code _____
 Stuffing Tube Size Code _____

Material Designator:
 A = Aluminum
 B = Brass
 C = CRES 316

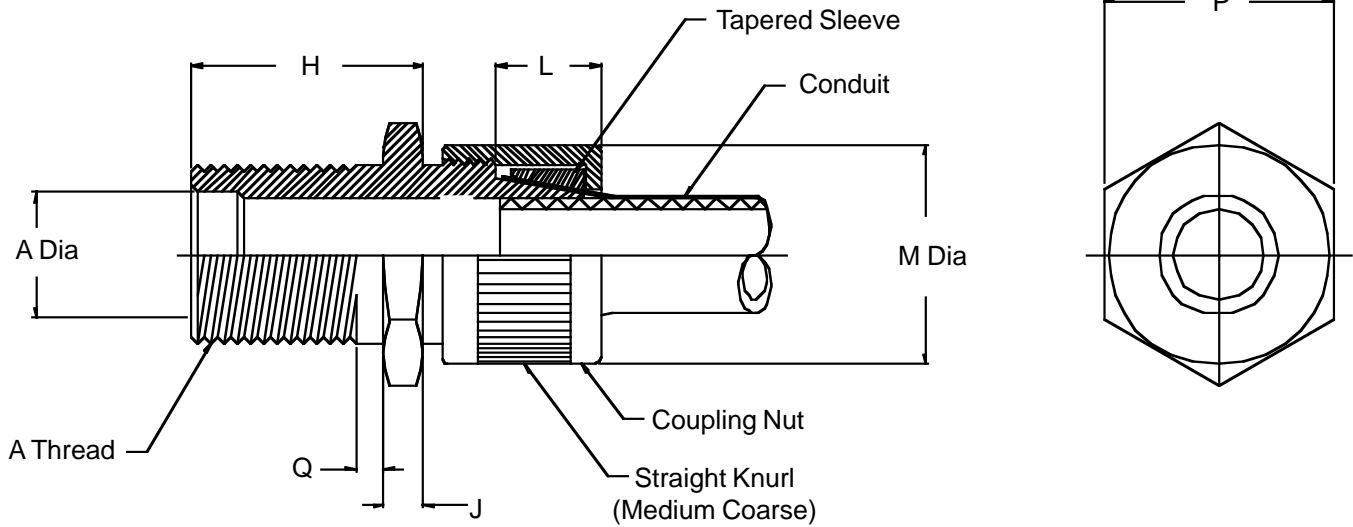

1. The M24758/7 adapter couples MIL-S-24235/9 through MIL-S-24235/17 stuffing tubes to M24758/1 conduit.
2. Any combination of conduit and stuffing tube sizes may be ordered by identifying the appropriate conduit size and stuffing tube size in the part number configuration.
3. Metric dimensions (mm) are indicated in parentheses.
4. For complete dimensions see applicable Military Specification.

TABLE I

Conduit Size Code	L		M Dia (Maximum)
	±.06	(15.2)	
02	.750	(19.1)	.930 (23.6)
03	.750	(19.1)	1.120 (28.4)
04	.750	(19.1)	1.250 (31.8)
05	.750	(19.1)	1.430 (36.3)
06	.750	(19.1)	1.620 (41.1)
08	1.000	(25.4)	1.810 (46.0)
10	1.000	(25.4)	2.180 (55.4)
12	1.000	(25.4)	2.560 (65.0)
16	1.000	(25.4)	3.060 (77.7)
20	1.000	(25.4)	3.680 (93.5)
24	1.000	(25.4)	4.380 (111.3)

TABLE II

MIL-S-24235 Stuffing Tube Size Code	A Thread (Class 2A)	A Dia	H ±.02 (.5)	J ±.02 (.5)	P Dim (Minimum)	Q ±.02 (.5)
A	0.875 - 12 UN	.406 (10.3)	1.063 (27.0)	.188 (4.8)	1.031 (26.2)	.188 (4.8)
B	1.000 - 12 UN	.515 (13.1)	1.063 (27.0)	.188 (4.8)	1.125 (28.6)	.188 (4.8)
C	1.125 - 12 UN	.640 (16.3)	1.063 (27.0)	.188 (4.8)	1.250 (31.8)	.188 (4.8)
D	1.250 - 12 UN	.750 (19.1)	1.063 (27.0)	.188 (4.8)	1.375 (34.9)	.188 (4.8)
E	1.250 - 12 UN	.812 (20.6)	1.063 (27.0)	.188 (4.8)	1.375 (34.9)	.188 (4.8)
F	1.313 - 12 UN	.843 (21.4)	1.188 (30.2)	.188 (4.8)	1.438 (36.5)	.188 (4.8)
G	1.500 - 12 UN	.935 (23.7)	1.188 (30.2)	.188 (4.8)	1.656 (42.1)	.188 (4.8)
J	1.625 - 12 UN	1.062 (27.0)	1.188 (30.2)	.188 (4.8)	1.781 (45.2)	.188 (4.8)
K	1.750 - 12 UN	1.171 (29.7)	1.500 (38.1)	.188 (4.8)	1.875 (47.6)	.188 (4.8)
L	1.813 - 12 UN	1.265 (32.1)	1.500 (38.1)	.188 (4.8)	1.938 (49.2)	.188 (4.8)
M	2.000 - 12 UN	1.406 (35.7)	1.500 (38.1)	.250 (6.4)	2.188 (55.6)	.188 (4.8)
N	2.063 - 12 UN	1.515 (38.5)	1.563 (39.7)	.250 (6.4)	2.250 (57.2)	.188 (4.8)
P	2.188 - 12 UN	1.625 (41.3)	1.563 (39.7)	.250 (6.4)	2.344 (59.5)	.188 (4.8)
R	2.313 - 12 UN	1.750 (44.5)	1.563 (39.7)	.250 (6.4)	2.469 (62.7)	.188 (4.8)
S	2.688 - 12 UN	1.875 (47.6)	2.188 (55.6)	.313 (8.0)	2.813 (71.5)	.250 (6.4)
T	2.875 - 12 UN	2.062 (52.4)	2.188 (55.6)	.313 (8.0)	2.969 (75.4)	.250 (6.4)
V	3.000 - 12 UN	2.187 (55.5)	2.188 (55.6)	.313 (8.0)	3.094 (78.6)	.250 (6.4)
W	3.125 - 12 UN	2.312 (58.7)	2.188 (55.6)	.313 (8.0)	3.281 (83.3)	.250 (6.4)
X	3.250 - 12 UN	2.500 (63.5)	2.188 (55.6)	.313 (8.0)	3.438 (87.3)	.250 (6.4)
Y	3.375 - 12 UN	2.609 (66.3)	2.188 (55.6)	.313 (8.0)	3.563 (90.5)	.250 (6.4)
Z	3.563 - 12 UN	2.781 (70.6)	2.188 (55.6)	.313 (8.0)	3.750 (95.3)	.250 (6.4)
AA	3.750 - 12 UN	2.875 (73.0)	3.125 (79.4)	.438 (11.1)	3.875 (98.4)	.250 (6.4)
BB	4.000 - 12 UN	3.157 (80.2)	3.125 (79.4)	.438 (11.1)	4.125 (104.8)	.250 (6.4)