



# AS85049/121

## Straight Strain Relief

### Self-Locking or Non-Self-Locking

**CONNECTOR DESIGNATOR:**
**F** MIL-DTL-38999 Series I and II

**Product Series and Basic Part Number**
**M85049/121**
**Dash No.**
*Table I  
Page 62-28*
**S**
**Finish**
*Table II  
Page 62-28*
**08**
**W**

**S** = Detented Self-Locking  
**N** = Non-Detented Self-Locking  
 Use Dash (-) for Non-Self-Locking  
 (See Note 5)

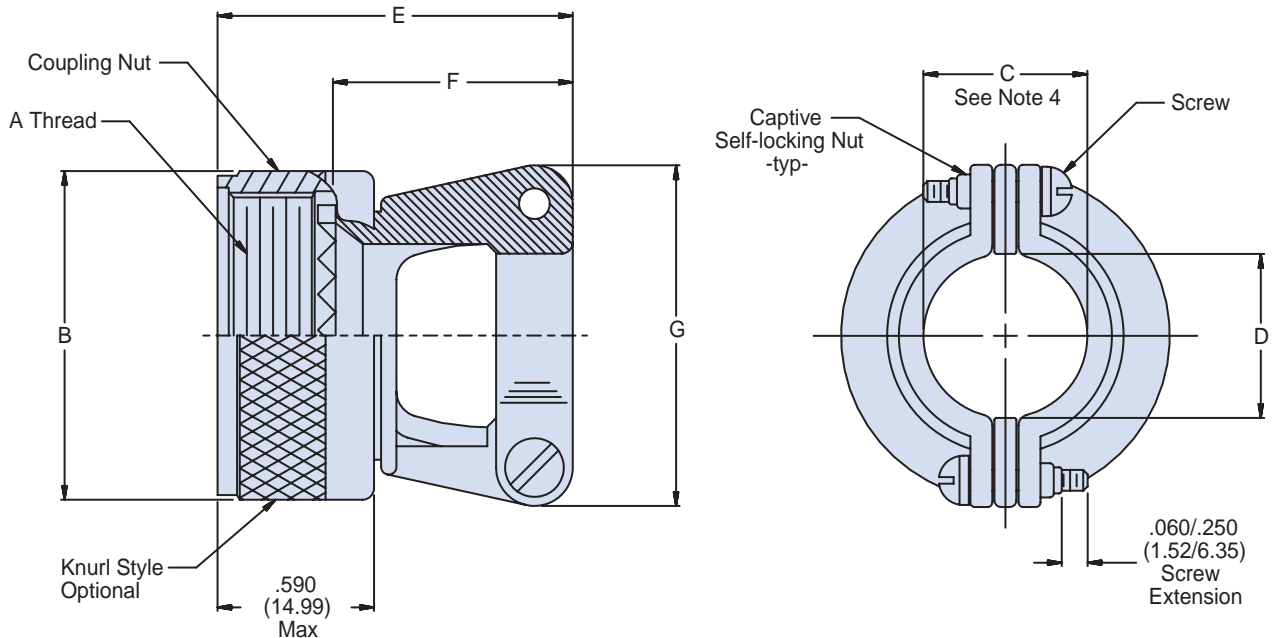
**APPLICATION NOTES**

1. Assembly to be identified with manufacturer's name and part number, space permitting.
2. Glenair Series 600 Backshell Assembly Tools are recommended for assembly and installation.
3. Metric equivalents in parentheses (mm) are given for general information only and are based on 1.000 inch = 25.4 mm.
4. Cable entry is measured with saddle bars closed and bottomed on clamp ears.
5. Detented self-locking has a positive audible detented coupling.
6. Material/Finish:  
 Clamp body, coupling nut, saddles - Al alloy or 300 Series SST/See Table II.  
 Clamp screws and lock nuts - CRES/Passivated, Silver plate optional.  
 Anti-rotation device - Corrosion resistant material

Dimensions in inches (millimeters) and are subject to change without notice.

AS85049/121  
Straight Strain Relief  
Self-Locking or Non-Self-Locking



AS85049

B

TABLE I: Dash Number, Shell Size, Thread and Dimensions (Continued Below)

Dash No.	Screw Size	Connector Shell Size		A Thread Class 2B	B Dia Max	C Dim ± .031 (0.79) See Note 4	D Min	E Max Length	F Dim	G Max
		Series I	Series II							
08	4-40	9	8	7/16-28 UNEF	.858 (21.8)	.219 (5.6)	.22 (5.6)	1.01 (25.7)	.77 (19.6) .51 (13.0)	.88 (22.4)
10	4-40	11	10	9/16-24 UNEF	.984 (25.0)	.264 (6.7)	.27 (6.9)	1.13 (28.7)	.89 (22.6) .64 (16.3)	.94 (23.9)
12	4-40	13	12	11/16-24 UNEF	1.157 (29.4)	.344 (8.7)	.35 (8.9)	1.25 (31.8)	1.01 (25.7) .76 (19.3)	1.12 (28.4)
14	4-40	15	14	13/16-20 UNEF	1.297 (32.5)	.460 (11.7)	.47 (11.9)	1.25 (31.8)	1.01 (25.7) .76 (19.3)	1.19 (30.2)
16	4-40	17	16	15/16-20 UNEF	1.406 (35.7)	.545 (13.8)	.55 (14.0)	1.37 (34.8)	1.13 (28.7) .88 (22.4)	1.44 (36.6)
18	6-32	19	18	1 1/16-18 UNEF	1.516 (38.5)	.615 (15.6)	.62 (15.7)	1.62 (41.1)	1.38 (35.1) 1.13 (28.7)	1.56 (39.6)
20	6-32	21	20	1 3/16-18 UNEF	1.642 (41.7)	.698 (17.7)	.70 (17.8)	1.75 (44.5)	1.51 (38.4) 1.26 (32.0)	1.69 (42.9)
22	6-32	23	22	1 5/16-18 UNEF	1.768 (44.9)	.780 (19.8)	.78 (19.8)	1.87 (47.5)	1.63 (41.4) 1.38 (35.1)	1.75 (44.5)
24	8-32	25	24	1 7/16-18 UNEF	1.869 (47.5)	.850 (21.6)	.85 (21.6)	2.00 (50.8)	1.76 (44.7) 1.51 (38.4)	1.88 (47.8)

TABLE II: Material and Finish

Symbol	Material	Finish
A	Aluminum Alloy	Black Anodize
N		Electroless Nickel
W		Cadmium, Olive Drab
X		Nickel Fluorocarbon Polymer
Y		Pure Dense Electrodeposited Aluminum
Z		Zinc Nickel
S	300 Series SST	Passivated

Dimensions in inches (millimeters) and are subject to change without notice.