



# 440-087 Ultra Lightweight Banding Strain Relief with Rotatable Coupling

**CONNECTOR DESIGNATOR:**

<b>F</b>	MIL-DTL-38999 Series I, II
<b>H</b>	MIL-DTL-38999 Series III and IV
<b>ROTATABLE COUPLING</b>	
<b>STANDARD PROFILE</b>	

**A**

**Product Series**  
440 - Banding Strain Relief

**Angle and Profile**  
A - 90° Clamp  
B - 45° Clamp  
S - Straight  
W - 90° Split Clamp

**Coupling Nut Finish Symbol**  
(See Table III)  
XM - 90° Elbow

**Supplied with 600-083 Band**  
(Omit if Not Required)

**440 F S 087 XM 20 B L**

**Connector Designator**  
F and H

**Basic Part Number**

**Connector Shell Size**  
(See Table II)

Add Letter "L" for Coupling Nut Less G Diameter  
Omit Letter "L" for Coupling Nut With G Diameter

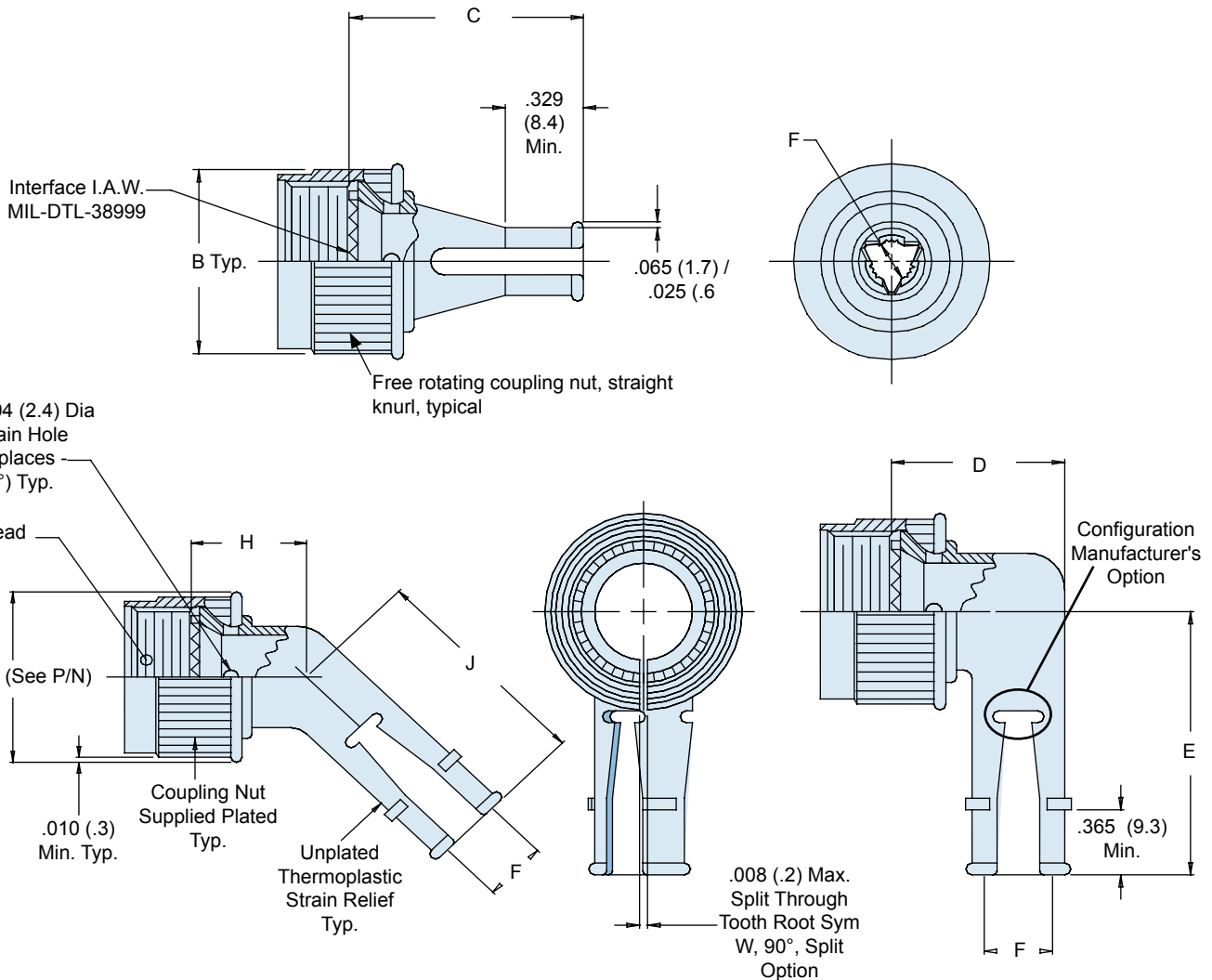

440-087  
Ultra Lightweight Banding Strain Relief  
with Rotatable Coupling



Composite  
Backshells

A

TABLE II: CONNECTOR SHELL SIZE ORDER NUMBER

Shell Size For Connector Designator		B	C	D		E
H	F	Max	Max	+03 -.06	(.8) (1.5)	Max
09	08	.562 (14.3)	1.22 (31.0)	.66	(16.8)	1.02 (25.9)
11	10	.688 (17.5)	1.22 (31.0)	.69	(17.5)	1.07 (27.2)
13	12	.817 (20.8)	1.22 (31.0)	.75	(19.1)	1.13 (28.7)
15	14	.930 (23.6)	1.22 (31.0)	.86	(21.8)	1.33 (33.8)
17	16	1.062 (27.0)	1.22 (31.0)	.94	(23.9)	1.40 (35.6)
19	18	1.188 (30.2)	1.22 (31.0)	1.00	(25.4)	1.46 (37.1)
21	20	1.312 (33.3)	1.30 (33.0)	1.07	(27.2)	1.61 (40.9)
23	22	1.438 (36.5)	1.30 (33.0)	1.15	(29.2)	1.66 (42.2)
25	24	1.562 (39.7)	1.30 (33.0)	1.21	(30.7)	1.72 (43.7)

TABLE II: CONNECTOR SHELL SIZE ORDER NUMBER (CONT.)

Shell Size For Connector Designator		F Cable Dia		G	H	J
H	F	Minimum	Maximum	Max	Max	Max
09	08	.094 (2.4)	.203 (5.2)	.65 (16.5)	.470 (11.9)	1.02 (25.9)
11	10	.141 (3.6)	.250 (6.4)	.76 (19.3)	.482 (12.2)	1.07 (27.2)
13	12	.172 (4.4)	.323 (8.2)	.89 (22.6)	.494 (12.5)	1.13 (28.7)
15	14	.203 (5.2)	.422 (10.7)	1.04 (26.4)	.530 (13.5)	1.33 (33.8)
17	16	.234 (5.9)	.500 (12.7)	1.16 (29.5)	.557 (14.1)	1.40 (35.6)
19	18	.265 (6.7)	.562 (14.3)	1.28 (32.5)	.576 (14.6)	1.46 (37.1)
21	20	.297 (7.5)	.625 (15.9)	1.40 (35.6)	.600 (15.2)	1.61 (40.9)
23	22	.328 (8.3)	.703 (17.9)	1.51 (38.4)	.627 (15.9)	1.66 (42.2)
25	24	.359 (9.1)	.765 (19.4)	1.63 (41.4)	.653 (16.6)	1.72 (43.7)

NOTES

- Metric dimensions (mm) are in parenthesis and are for reference only.
- See Table I in Intro for front-end dimensional details.

TABLE III: FINISH

Symbol	Material / Finish Description
XM	Coupling Nut: Aluminum / Electroless Nickel Body: Thermoplastic / Black Color
XMT	Coupling Nut: Aluminum / 1000 Hour Grey™ Body: Thermoplastic / Black Color
XW	Coupling Nut: Aluminum / Cad O.D. over Electroless Nickel Body: Thermoplastic / Black Color