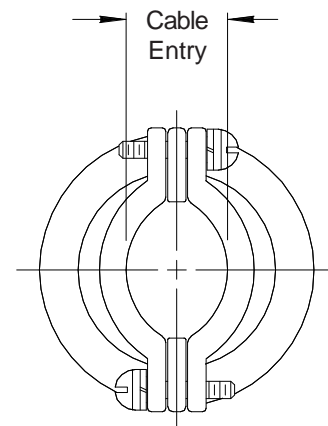
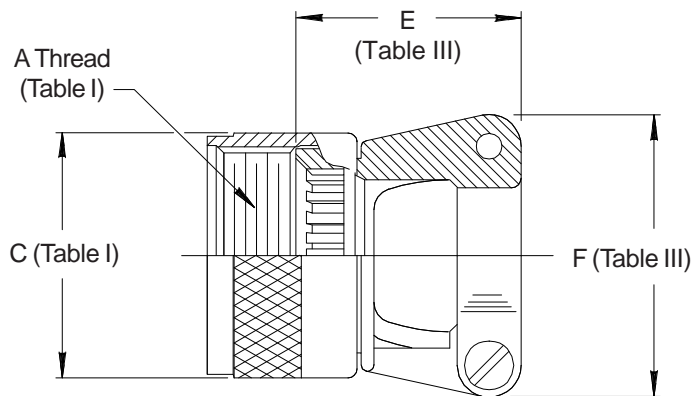
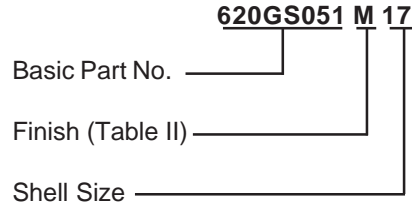

**CONNECTOR
DESIGNATOR**
G
**ROTATABLE
COUPLING**

See inside back cover fold-out or pages 13 and 14 for Tables I and II.

TABLE III: CABLE ENTRY

Shell Size	E Max	F Max	Cable Entry	
			Closed	Open
11	1.091 (27.7)	.903 (22.9)	.177 (4.5)	.286 (7.3)
13	1.091 (27.7)	.977 (24.8)	.177 (4.5)	.286 (7.3)
15	1.091 (27.7)	1.151 (29.2)	.250 (6.4)	.416 (10.6)
17	1.206 (30.6)	1.281 (32.5)	.291 (7.4)	.476 (12.1)
19	1.320 (33.5)	1.406 (35.7)	.348 (8.8)	.626 (15.9)
23	1.445 (36.7)	1.576 (40.0)	.429 (10.9)	.831 (21.1)
25	1.570 (39.9)	1.666 (42.3)	.523 (13.3)	.956 (24.3)
29	1.721 (43.7)	2.046 (52.0)	.643 (16.3)	1.081 (27.5)
33	1.908 (48.5)	2.209 (56.1)	.704 (17.9)	1.187 (30.1)

1. Cable Entry is defined as the accommodation entry for the wire bundle or cable. Dimensions are not intended for inspection criteria.
2. Metric dimensions (mm) are indicated in parentheses.