

667-009 Plug and 667-010 Receptacle Protective Covers - Composite
For Glenair 257-007 Connectors

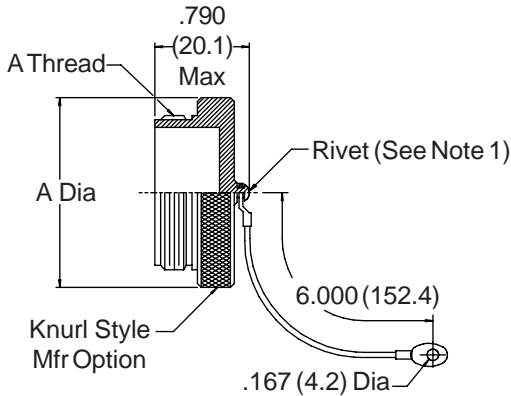

667-009 PLUG COVER



Product Series **667-009-14**
 Shell Size (Table I)

667-010 RECEPTACLE COVER

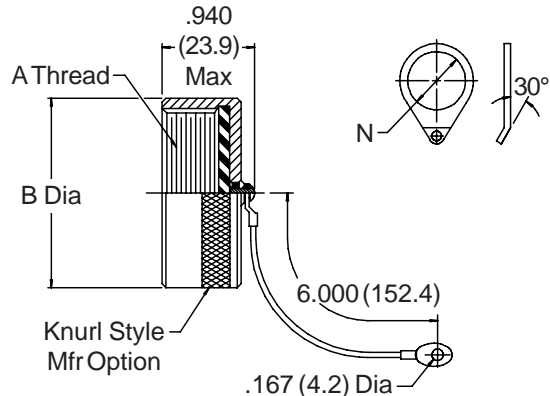

Product Series No. **667-010-14-03**
 Shell Size (Table I)
 Attachment Ring (Table III)
 Omit for Standard Lug Termination

TABLE I

SHELL SIZE	A MAX	B MAX	A THREAD CLASS 2A
10	1.031 (26.2)	.820 (20.8)	.625 - .1P - .1L
12	1.125 (28.6)	.940 (23.9)	.750 - .1P - .1L
14	1.219 (31.0)	1.060 (26.9)	.875 - .1P - .1L
16	1.312 (33.3)	1.190 (30.2)	1.000 - .1P - .1L
18	1.406 (35.7)	1.320 (33.5)	1.125 - .1P - .1L
20	1.531 (38.9)	1.440 (36.6)	1.250 - .1P - .1L
22	1.645 (41.8)	-	1.375 - .1P - .1L
24	1.781 (45.2)	1.690 (42.9)	1.500 - .1P - .1L
28	2.031 (51.6)	1.940 (49.3)	1.750 - .1P - .1L

TABLE II

DASH NO.	SHELL SIZE	N DIA
01	10	.765 (19.4)
02	12	.890 (22.6)
03	14	1.015 (25.8)
04	16	1.140 (29.0)
05	18	1.265 (32.1)
06	20	1.577 (40.1)
08	22	-
10	24	1.765 (44.8)
13	28	2.077 (52.8)

Notes:

1. Metric dimensions (mm) are indicated in parentheses.
2. Rivet to be ultrasonically or chemically welded to cover.
3. Plug cover mates with Glenair 257-007 and 190-015 Connectors; Receptacle cover mates with 257-007-2, 190-016 and 190-019 Connectors.
4. Attachment is Wire Rope, Heavy Duty, Cres/Passivated with black polyurethane jacketing.
5. Material/Finish: Cover and Rivet - Ultem