

**AS85049/34**  
**Straight Adapter and Extender**  
 for Use with MS3114 and MS3124 Connectors



AS85049

CONNECTOR DESIGNATOR:	
<b>D</b>	MIL-DTL-26482 Series I

For Use With  
 MS3114 and MS3124  
 Connectors Only

Basic Part Number	Shell Size (Table I)
<b>M85049/34</b>	<b>- 12 W</b>
<b>Finish</b> <i>W = 1000 Hr. Cadmium Olive Drab</i> <i>X = Nickel Fluorocarbon Polymer</i> <i>Y = Pure Dense Electrodeposited Aluminum</i> <i>Z = Zinc Nickel, Black</i>	

**B**

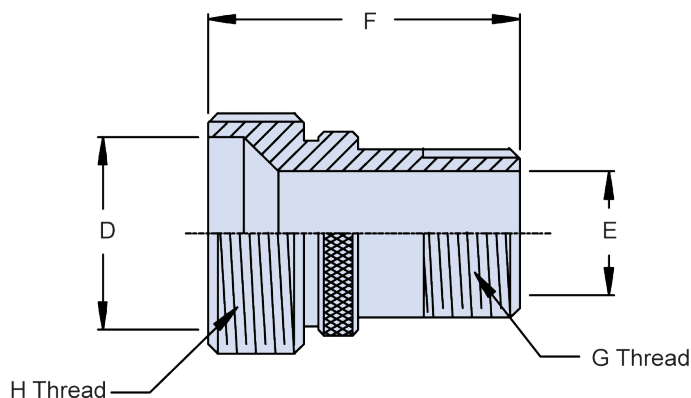

Shell Size	G Thread UNEF Class 2A	H Thread UNEF Class 2A	D Dia	E Dia	F Max
<b>8</b>	.4375 - 28	.625 - 24	.500 (12.7)	.327 (8.3)	.812 (20.6)
<b>10</b>	.5625 - 24	.750 - 20	.609 (15.5)	.444 (11.3)	.812 (20.6)
<b>12</b>	.6875 - 24	.875 - 20	.734 (18.6)	.569 (14.5)	.812 (20.6)
<b>14</b>	.8125 - 20	1.000 - 20	.859 (21.8)	.673 (17.1)	.812 (20.6)
<b>16</b>	.9375 - 20	1.125 - 18	.969 (24.6)	.798 (20.3)	.812 (20.6)
<b>18</b>	1.0625 - 18	1.250 - 18	1.109 (28.2)	.915 (23.2)	.812 (20.6)
<b>20</b>	1.1875 - 18	1.375 - 18	1.219 (31.0)	1.030 (26.2)	.906 (23.0)
<b>22</b>	1.3125 - 18	1.500 - 18	1.344 (34.1)	1.155 (29.3)	.906 (23.0)
<b>24</b>	1.4375 - 18	1.625 - 18	1.469 (37.3)	1.280 (32.5)	.937 (23.8)

- APPLICATION NOTES**
- For complete dimensions see the applicable Military Specification.
  - Metric dimensions (mm) are in parentheses.

Dimensions in inches (millimeters) and are subject to change without notice.