

CONNECTOR DESIGNATOR:

F MIL-DTL-27599

Basic Part Number

Dash Number

M85049/61 - 10

TABLE I: Dash Number and Dimensions

Dash No.	Shell Size (Ref)	A Thread UNEF-2B	B Dia Max	C Dia Max	D Dia $\pm .005 (.1)$
8	8/9	.4375-28	.594 (15.1)	.521 (13.2)	.476 (12.1)
10	10/11	.5625-24	.734 (18.6)	.647(16.4)	.602 (15.3)
12	12/13	.6875-24	.844 (21.4)	.771 (19.6)	.726 (18.4)
14	14/15	.8125-20	.969 (24.6)	.897 (22.8)	.852 (21.6)
16	16/17	.9375-20	1.094 (27.8)	1.023 (26.0)	.978 (24.8)
18	18/19	1.0625-18	1.234 (31.3)	1.147 (29.1)	1.102 (28.0)
20	20/21	1.1875-18	1.344 (34.1)	1.273 (32.3)	1.228 (31.2)
22	22/23	1.3125-18	1.469 (37.3)	1.397 (35.5)	1.352 (34.3)
24	24/25	1.4375-18	1.594 (40.5)	1.524 (38.7)	1.478 (37.5)

APPLICATION NOTES

- For complete dimensions see the applicable Military Specification.
- Finish: 500-Hour Cadmium Olive Drab over Electroless Nickel.
- See Pages 30-4 and 68-13 for the AS85049/75 Potting Boot which can be used with this potting ring and Page 88-13
- Metric dimensions (mm) are in parentheses.

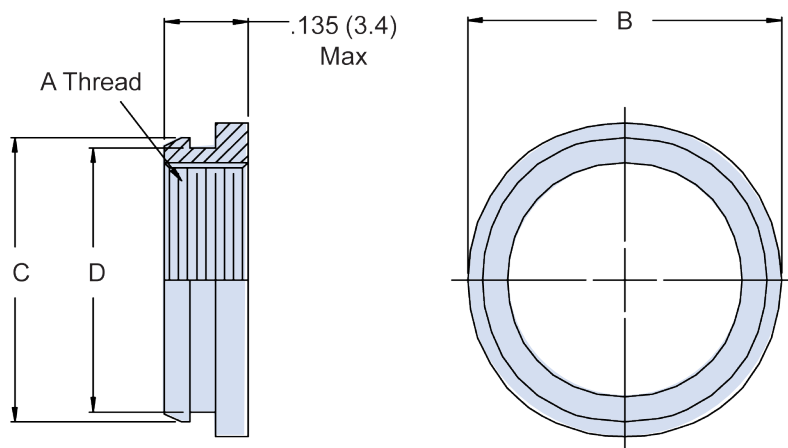
Dimensions in inches (millimeters) and are subject to change without notice.