

U.S. PATENT NOS. 6358077, 6419519

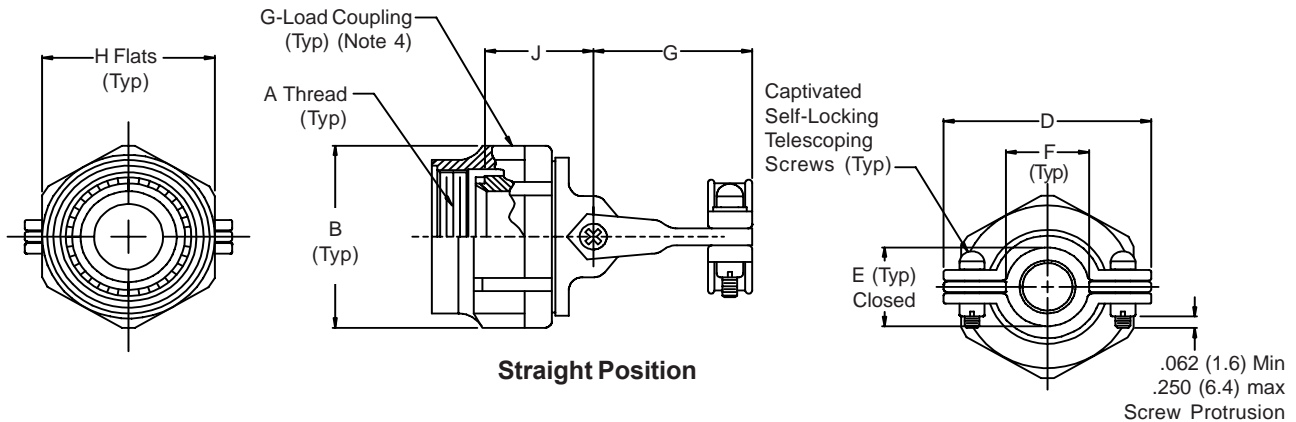

627 A 089 XO 16

Product Series
Connector Designator (A, F & H)
Basic Number
Finish Symbol (Table II)
Dash Number (Table I)

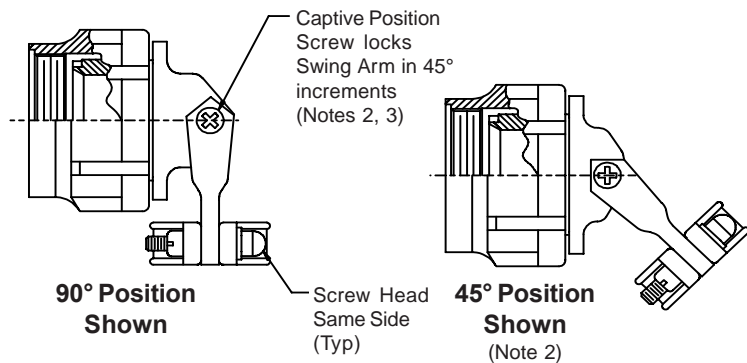

TABLE II: FINISH

XM*	Electroless Nickel
XW*	Cadmium Olive Drab Over Electroless Nickel
XO	No Plating - Base Material Non-conductive
XB	No Plating - Black Material

* Note: Coupling nut & Saddle Bars supplied unplated.

NOTES:

- Glenair series 600 Backshell assembly Tools are recommended for assembly and installation.
- Swing Arm locks in 45° increments—Sizes 08 thru 24, additional positioning increments are manufacturer's option.
- Captive Screw can remain engaged to the body when positioning the Arm. When tightened, the Screw shall not protrude into the inside surfaces.
- G-Load Coupling provides accessory tooth engagement and Self-Locking features.

TABLE I: CONNECTOR DESIGNATOR

Shell Size for Connector Designator*			B Dia	D	E - Cable Entry - F		G	H Flats		J
A	F	H	Max	Max	±.06 (1.5)	Min	Max	Max	Min	±.03 0.8
08	08	09	.812 (20.6)	.980 (24.9)	.265 (6.7)	.220 (5.9)	1.060 (26.9)	.750 (19.1)	.736 (18.7)	.880 (22.4)
10	10	11	.938 (23.8)	1.050 (26.7)	.310 (7.9)	.270 (6.9)	1.090 (27.7)	.875 (22.2)	.860 (21.8)	.910 (23.1)
12	12	13	1.125 (28.6)	1.200 (30.5)	.390 (9.9)	.350 (8.9)	1.180 (30.0)	1.000 (25.4)	.980 (24.9)	.950 (24.1)
14	14	15	1.250 (31.8)	1.300 (33.0)	.506 (12.9)	.470 (11.9)	1.240 (31.5)	1.125 (28.6)	1.100 (27.9)	1.010 (25.7)
16	16	17	1.375 (34.9)	1.440 (36.6)	.591 (15.0)	.550 (14.0)	1.320 (33.5)	1.250 (31.8)	1.224 (31.1)	1.050 (26.7)
18	18	19	1.500 (38.1)	1.560 (39.6)	.661 (16.8)	.620 (15.7)	1.390 (35.3)	1.375 (34.9)	1.469 (37.3)	1.080 (30.0)
20	20	21	1.625 (41.3)	1.690 (42.9)	.744 (18.9)	.700 (17.8)	1.550 (39.4)	1.500 (38.1)	1.500 (38.1)	1.120 (28.4)
22	22	23	1.750 (44.5)	1.770 (45.0)	.826 (21.0)	.780 (19.8)	1.550 (39.4)	1.625 (41.3)	1.581 (40.2)	1.160 (29.5)
24	24	25	1.875 (47.6)	1.890 (48.0)	.896 (22.8)	.850 (21.6)	1.610 (40.9)	1.750 (44.5)	1.960 (49.8)	1.200 (30.5)

*See Introduction Page 4 **Consult factory for additional entry sizes available.

Metric dimensions (mm) are in parentheses and are for reference only.