

AS85049/31, MS3416 and MIL-DTL-85723/15N Self-Locking and Non-Self-Locking E-Nut



AS85049

B

CONNECTOR DESIGNATOR:

A

AS50151 Series AS34001 Crimp,
MIL-DTL-26482 Series II,
SAE AS81703 Crimp Series III,
MIL-DTL-83723 Series I,
MIL-DTL-83723 Series III

Finish

A = Anodize, Black
N = Electroless Nickel
W = 1,000 Hour Cadmium Olive Drab
over Electroless Nickel
X = Nickel Fluorocarbon Polymer
Y = Pure Dense Electrodeposited
Aluminum
Z = Zinc-Nickel, Black

Basic Part
Number

M85049/31

S

22

W

S = Self-Locking
N = Non-Detented
Use Dash for
Non-Self-Locking

Shell
Size

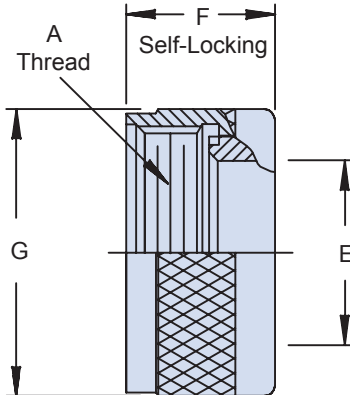

Superseded Part Number

M83723/15N-10 A

Basic Part No.
(Non-Self-
Locking Only)

Dash No.

Finish Designator
A = Non-Conductive, Black Anodize
R = Conductive, Electroless Nickel

Superseded Part Number

MS3416 -10-E A

Basic Part No.
(Non-Self-
Locking Only)

Dash No.

Style

Metal and Finish Designator
A = Aluminum 500 Hour Cad. Olive
Drab Over Electroless Nickel
C = Aluminum, Cadmium Olive Drab
G = Aluminum, Black Anodize
N = Aluminum, Electroless Nickel

APPLICATION NOTES

- For complete dimensions, see the applicable Military Specification.
- Metric dimensions (mm) are indicated in parentheses.

TABLE I: Shell Size, Thread and Dimensions

Shell Size	A Thread Class 2B	Ø E Max	F Max	Ø G Max
3	.562 - 24 UNEF	.270 (6.9)	--	--
8	.500 - 20 UNF	.270 (6.9)	.710 (18.0)	.885 (22.5)
10	.625 - 24 UNEF	.375 (9.5)	.710 (18.0)	1.010 (25.7)
12	.750 - 20 UNEF	.511 (13.0)	.710 (18.0)	1.135 (28.8)
14	.875 - 20 UNEF	.585 (14.9)	.710 (18.0)	1.260 (32.0)
16	1.000 - 20 UNEF	.710 (18.0)	.710 (18.0)	1.385 (35.2)
18	1.062 - 18 UNEF	.789 (20.0)	.710 (18.0)	1.510 (38.4)
20	1.188 - 18 UNEF	.914 (23.2)	.710 (18.0)	1.635 (41.5)
22	1.313 - 18 UNEF	1.039 (26.4)	.710 (18.0)	1.760 (44.7)
24	1.438 - 18 UNEF	1.154 (29.3)	.710 (18.0)	1.885 (47.9)
28	1.750 - 18 UNS	1.389 (35.3)	.890 (22.6)	2.135 (54.2)
32	2.000 - 18 UNS	1.635 (41.5)	.890 (22.6)	2.395 (60.8)
36	2.250 - 16 UN	1.850 (47.0)	.890 (22.6)	2.635 (66.9)
40	2.500 - 16 UN	2.065 (52.5)	.890 (22.6)	2.885 (73.3)
44	2.750 - 16 UN	2.320 (58.9)	.890 (22.6)	3.135 (79.6)
48	3.000 - 16 UN	2.570 (65.3)	.890 (22.6)	3.385 (86.0)
61	1.500 - 18 UNEF	1.194 (30.3)	--	--

Dimensions in inches (millimeters) and are subject to change without notice.