

AS85049/75 Potting Boot

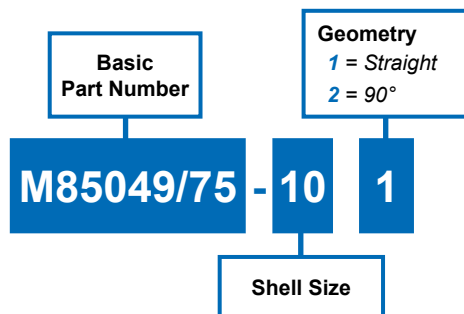

For Use with M85049/58
Potting Boot Ring (Page 30-3)

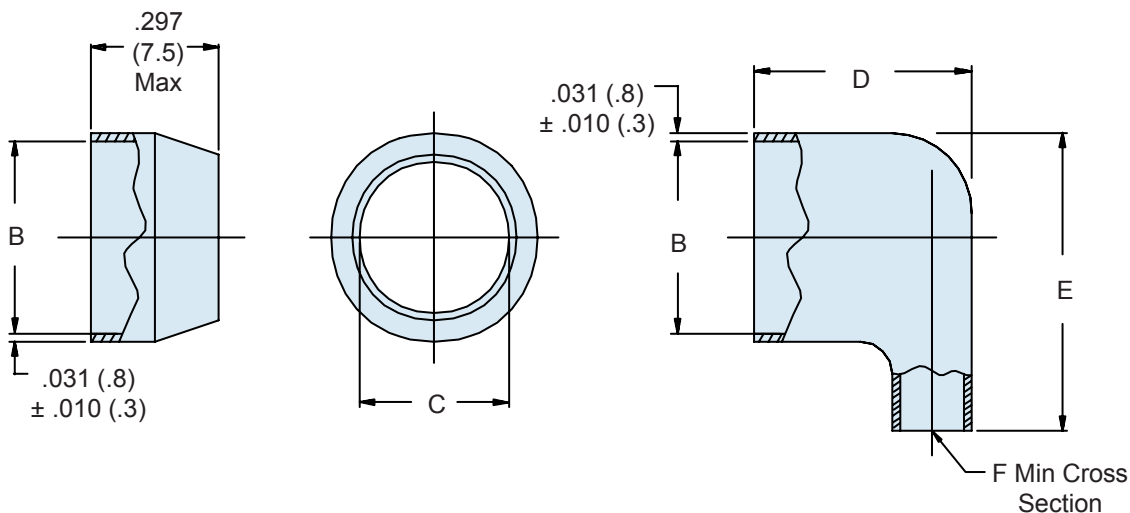

APPLICATION NOTES

1. Assembly identified with manufacturer's name and part number, space permitting.
2. For complete dimensions, see the applicable Military Specification.
3. Material/Finish:
Adapter - Translucent nylon, minimum wall thickness .020 (.51).
4. Metric dimensions (mm) are in parentheses.

AS85049/75 Potting Boot



TABLE I: Reference for Connector Shell Size

Dash No.	Ø B		C		D		E		F	
	±.005	(.1)	Min ID	Max	Max	Max	Max	Min	Min	
8	.527	(13.4)	.434	(11.0)	.438	(11.1)	.766	(19.5)	.073	(1.9)
10	.652	(16.6)	.548	(13.9)	.469	(11.9)	.891	(22.6)	.117	(3.0)
12	.776	(19.7)	.673	(17.1)	.562	(14.3)	1.031	(26.2)	.206	(5.2)
14	.898	(22.8)	.798	(20.3)	.719	(18.3)	1.156	(29.4)	.384	(9.8)
16	1.016	(25.8)	.899	(22.8)	.781	(19.8)	1.287	(32.7)	.443	(11.3)
18	1.140	(29.0)	1.024	(26.0)	.844	(21.4)	1.406	(35.7)	.561	(14.2)
20	1.265	(32.1)	1.149	(29.2)	.906	(23.0)	1.531	(38.9)	.693	(17.6)
22	1.390	(35.3)	1.274	(32.4)	.938	(23.8)	1.656	(42.1)	.840	(21.3)
24	1.515	(38.5)	1.399	(35.5)	1.031	(26.2)	1.781	(45.2)	.999	(25.4)