



THE WORLD'S MOST COMPLETE SELECTION OF MIL-SPEC

BACKSHELLS

AND CONNECTOR ACCESSORIES—FROM AS85049 TO MIL-DTL-38999

NOVEMBER 2013

QUALIFIED
MIL-SPEC

Connector Backshells and Accessories

*Tens of thousands of parts in-stock
and ready for immediate shipment*



Most customers have a simple expectation when they go shopping for safety-critical interconnect components: they want fast and accurate service. Glenair stocks tens of thousands of qualified mil-spec backshells and connector accessories—bagged and tagged and ready for immediate shipment. In fact, Glenair is the world's largest manufacturer and supplier of mil-spec backshells and connector accessories with more listed QPL's and more manufacturing experience than any other supplier. You have a simple expectation: fast and accurate service. At Glenair, we're ready to give you exactly that. It's a promise.

Glenair®

Glenair, Inc.
1211 Air Way
Glendale, CA
91201-2497
818-247-6000
sales@glenair.com
www.glenair.com



Part Number Index and Introduction

A



AS85049 Qualified Backshells and Connector Accessories

B

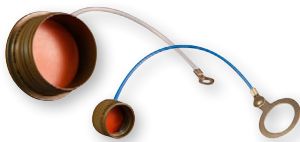

MIL-DTL-38999 Qualified Connector Accessories

C



MIL-DTL-28840 Qualified Backshells and Connector Accessories

D



MIL-DTL-83723 Qualified Backshells and Connector Accessories

E



AS81511 Qualified Backshells and Connector Accessories

F



Miscellaneous Qualified Backshells and Connector Accessories

G



Backshell-to-Connector Assembly Tools

H



Quick-Reference Part Number Index

J

Dimensions in inches (millimeters) and are subject to change without notice.



Military Standard Backshells and Accessories Part and Page Number Index

A

SECTION B • AS85049 QUALIFIED PRODUCTS • SECTION B

Industry Specification Number	Part Identification Number	Military Part Number Superseded	Glenair Commercial Part Number	Description	Glenair Connector Designator/Interface	Page No.
AS85049/1	M85049/1	MS3057 "B"	620-053 Style B	Straight Strain Relief	MS "V" Thread	B-2
AS85049/2	M85049/2	MS3057 "C"	620-053 Style C	Straight Environmental Strain Relief	MS "V" Thread	B-3
AS85049/3	M85049/3 Style 1 M85049/3 Style 2 M85049/3 Style 3	MS17340/MS90571 Style 1 MS17340/MS90571 Style 2 MS17340/MS90571 Style 3	GS85049/3 377	Straight Environmental Backshell	"C" MIL-DTL-22992, C, J & R	B-4 B-5 B-6
AS85049/4	M85049/4 Style 1 M85049/4 Style 2 M85049/4 Style 3	MS17342/MS90569 Style 1 MS17342/MS90569 Style 2 MS17342/MS90569 Style 3	GS85049/4 377	Straight Step-Up Environmental Backshell	"C" MIL-DTL-22992, C, J & R	B-7 B-9 B-11
AS85049/5	M85049/5 Style 1 M85049/5 Style 2 M85049/5 Style 3	MS17341/MS90570 Style 1 MS17341/MS90570 Style 2 MS17341/MS90570 Style 3	377-034	Straight Step-Down Environmental Backshell	"C" MIL-DTL-22992, C, J & R	B-13 B-15 B-17
AS85049/6	M85049/6	MS3189A	390AB001	45° RFI/EMI Environmental Backshell	"A" AS50151; MIL-DTL-26482, Series 2; AS81703 Series 3; MIL-DTL-83723, Series III	B-19
AS85049/7	M85049/7	MS3189B	370AB001	45° Environmental Backshell	"A" AS50151; MIL-DTL-26482, Series 2; AS81703 Series 3; MIL-DTL-83723, Series III	B-21
AS85049/8	M85049/8	MS3188A	390AA001	90° RFI/EMI Environmental Backshell	"A" AS50151; MIL-DTL-26482, Series 2; AS81703 Series 3; MIL-DTL-83723, Series III	B-23
AS85049/9	M85049/9	MS3188B	360-061	90° Environmental Backshell	"A" AS50151; MIL-DTL-26482, Series 2; AS81703 Series 3; MIL-DTL-83723, Series III	B-25
AS85049/10	M85049/10	MS3437A	390AS001	Straight RFI/EMI Environmental Backshell	"A" AS50151; MIL-DTL-26482, Series 2; AS81703 Series 3; MIL-DTL-83723, Series III	B-27
AS85049/11	M85049/11	MS3437B	370AS001	Straight Environmental Backshell	"A" AS50151; MIL-DTL-26482, Series 2; AS81703 Series 3; MIL-DTL-83723, Series III	B-31
AS85049/14	M85049/14- M85049/14 N M85049/14 S	MIL-C-85049/14	610HS011	E Nut E Nut, Non-Detented, Self Locking E Nut, Detented, Self-Locking	"H" MIL-DTL-38999, Ser. III & IV EN3645	B-35
AS85049/15	M85049/15- M85049/15 N M85049/15 S M85049/15 G M85049/15 H	MIL-C-85049/15	450HB001 450HB041 450HB043 450HB043 "G" 450HB041 "G"	45° Qwik-Ty® Strain Relief Non-Detented, Self-Locking Detented Self-Locking Detented, Self-Locking, Ground Lug Non-Detented Self-Locking, Ground Lug	"H" MIL-DTL-38999, Ser. III & IV; EN3645	B-36
AS85049/16	M85049/16- M85049/16 N M85049/16 S M85049/16 G M85049/16 H	MIL-C-85049/16	450HA001 450HA041 450HA043 450HA043 "G" 450HA041 "G"	90° Qwik-Ty® Strain Relief Non-Detented, Self-Locking Detented Self-Locking Detented, Self-Locking, Ground Lug Non-Detented Self-Locking, Ground Lug	"H" MIL-DTL-38999, Ser. III & IV; EN3645	B-36
AS85049/17	M85049/17	MIL-C-38999/5	390FS012	Straight RFI/EMI Environmental Backshell	"F" MIL-DTL-38999 Series I & II	B-37
AS85049/18	M85049/18	MIL-C-85049/18	390HS011	Straight RFI/EMI Environmental Backshell	"H" MIL-DTL-38999, Ser. III & IV; EN3645	B-38
AS85049/19	M85049/19	MIL-C-85049/19	380HS007	Straight Environmental Backshell	"H" MIL-DTL-38999, Ser. III & IV; EN3645	B-39

Dimensions in inches (millimeters) and are subject to change without notice.
Mil-Spec Backshells and Accessories U.S. CAGE Code 06324

Rev. 5/30/14
Printed in U.S.A.

© 2013 Glenair, Inc.

Military Standard Backshells and Accessories Part and Page Number Index



SECTION B • AS85049 QUALIFIED PRODUCTS • SECTION B

Industry Specification Number	Part Identification Number	Military Part Number Superseded	Glenair Commercial Part Number	Description	Glenair Connector Designator/Interface	Page No.
AS85049/20	M85049/20	MIL-C-85049/20	440HS063	Straight Crimp Ring Backshell and Crimp Ring	"H" MIL-DTL-38999, Ser. III & IV; EN3645	B-41
AS85049/21	M85049/21	MIL-C-85049/21	360HS002	Straight Non-Environmental Strain Relief Backshell	"H" MIL-DTL-38999, Ser. III & IV; EN3645	B-42
AS85049/23	M85049/23	MS3189C	380AB001	45° RFI-EMI Non-Environmental Backshell	"A" AS50151; MIL-DTL-26482, Series 2; AS81703 Series 3; MIL-DTL-83723, Series III	B-43
AS85049/24	M85049/24	MS3188C	390AA001	90° RFI-EMI Non-Environmental Backshell	"A" AS50151; MIL-DTL-26482, Series 2; AS81703 Series 3; MIL-DTL-83723, Series III	B-45
AS85049/25	M85049/25	MS3437C	380AS001	Straight RFI-EMI Non-Environmental Backshell	"A" AS50151; MIL-DTL-26482, Series 2; AS81703 Series 3; MIL-DTL-83723, Series III	B-47
AS85049/26	M85049/26-1 M85049/26-2 M85049/26-3	MS3419 MS3161 MIL-C-85049/26-3	440AS063 687-150	Adapter Only Crimp Ring Only Adapter with Crimp Ring	"A" AS50151; MIL-DTL-26482, Series 2; AS81703 Series 3; MIL-DTL-83723, Series III	B-51 B-52
AS85049/27	M85049/27- M85049/27 N M85049/27 S	MIL-DTL-38999/1	610FS011	E Nut E Nut, Non-Detented, Self-Locking E Nut, Detented, Self-Locking	"F" MIL-DTL-38999 Series I & II	B-53
AS85049/28	M85049/28	M83733/15	G61570	Strt. Rectangular Non-Environmental Backshell	---	B-54
AS85049/29	M85049/29	MIL-DTL-38999/6	360FS002	Straight Non-Environmental Strain Relief Backshell	"F" MIL-DTL-38999 Series I & II	B-55
AS85049/30	M85049/30	MIL-DTL-38999/4	400FS001	Straight RFI-EMI Individual Shield Termination Backshell	"F" MIL-DTL-38999 Series I & II	B-56
AS85049/31	M85049/31- M85049/31 N M85049/31 S	MS3416	610AS011	E Nut E Nut, Non-Detented, Self-Locking E Nut, Detented, Self Locking	"A" AS50151; MIL-DTL-26482, Series 2; AS81703 Series 3; MIL-DTL-83723, Series III	B-57
AS85049/33	M85049/33-2	MIL-DTL-38999/2	440FS063	Straight Crimp Ring Non-Environmental Backshell	"F" MIL-DTL-38999 Series I & II	B-58
AS85049/34	M85049/34	MS3484	320	Straight Adapter and Extender For use with MS3114 & MS3124 Connectors	"D" MIL-DTL-26482 Series I	B-59
AS85049/36	M85049/36	MIL-DTL-38999/7	380FS008	Straight RFI-EMI Non-Environmental Backshell	"F" MIL-DTL-38999 Series I & II	B-60
AS85049/37	M85049/37	MIL-DTL-38999/8	380FD007	90° RFI-EMI Non-Environmental Backshell	"F" MIL-DTL-38999 Series I & II	B-61
AS85049/38	M85049/38 N M85049/38 S	MIL-C-85049/38-	620HS011 620HS048	Str. Strain Relief, Non-Detented Self-Locking Straight Strain Relief, Detented Self-Locking	"H" MIL-DTL-38999 Series III & IV EN3645	B-62
AS85049/39	M85049/39	MIL-C-85049/39	620HA011 620HA048	90° Strain Relief, Non-Detented Self-Locking 90° Strain Relief, Detented Self-Locking	"H" MIL-DTL-38999 Series III & IV; EN3645	B-63
AS85049/41	M85049/41	MS3057A	620-053 Style A	Straight Strain Relief	MS "V" Thread	B-64
AS85049/42	M85049/42	MS3057D	620-053 Style H	Straight Strain Relief	MS "V" Thread	B-65
AS85049/43	M85049/43	MS3415	620AB047	45° Strain Relief	---	B-66
AS85049/44	M85049/44	M83733/16	G61257	Straight Rectangular Strain Relief Backshell	---	B-67
AS85049/45	M85049/45	MS27663	440FS037	Straight Strain Relief	"F" MIL-DTL-38999 Series I & II	B-68
AS85049/46	M85049/46	MS27663	440FA037	90° Non-Self-Locking Composite Strain Relief	"F" MIL-DTL-38999 Series I & II	B-69

Dimensions in inches (millimeters) and are subject to change without notice.



Military Standard Backshells and Accessories Part and Page Number Index

SECTION B • AS85049 QUALIFIED PRODUCTS • SECTION B

Industry Specification Number	Part Identification Number	Military Part Number Superseded	Glenair Commercial Part Number	Description	Glenair Connector Designator/Interface	Page No.
AS85049/47	M85049/47	MS27507	620FA012	90° Self-Locking or Non-Self-Locking Strain Relief	"F" MIL-DTL-38999 Series I & II	B-70
AS85049/48	M85049/48-1 M85049/48-2 M85049/48-3	M24308/20 M24308/21 M24308/22	GS85049/48 550/557	Rectangular Strain Relief Backshell	MIL-DTL-24308	B-71 B-72 B-73
AS85049/49	M85049/49-2	MS27506	620FS054	Straight Strain Relief	"F" MIL-DTL-38999 Series I & II	B-74
AS85049/50	M85049/50	MS24308/19	GS85049/50 550/557	Rectangular Strain Relief Backshell	MIL-DTL-24308	B-75
AS85049/51	M85049/51	MS3418	620AA046	90° Self-Locking or Non-Self-Locking Strain Relief	"A" AS50151; MIL-DTL-26482, Series 2; AS81703 Series 3; MIL-DTL-83723, Series III	B-76
AS85049/52	M85049/52	MS3417	620AS046	Straight Self-Locking or Non-Self-Locking Strain Relief	"A" AS50151; MIL-DTL-26482, Series 2; AS81703 Series 3; MIL-DTL-83723, Series III	B-77
AS85049/53 AS85049/54 AS85049/55	M85049/53 M85049/54 M85049/55	MS3152 MS3153 MS3154	450AS001 450BS001 450AA001	Straight Qwik-Ty® Strain Relief 45° Qwik-Ty® Strain Relief 90° Qwik-Ty® Strain Relief	"A" AS50151; MIL-DTL-26482, Series 2; AS81703 Series 3; MIL-DTL-83723, Series III	B-78
AS85049/56 AS85049/57	M85049/56 M85049/57	MS27668 MS27669	450FS001 450FB001	Straight Qwik-Ty® Strain Relief 45° Qwik-Ty® Strain Relief	"F" MIL-DTL-38999 Ser. I & II	B-79
AS85049/58	M85049/58	MS27485	GS85049/58 310	Potting Boot Ring	"F" MIL-DTL-38999 Ser. I & II	B-80
AS85049/59	M85049/59	MS90568	310CS002	Straight Shrink Boot Adapter	"C" MIL-DTL-22992	B-81
AS85049/60	M85049/60-1 M85049/60-2G	MS3158 MS3416	310AS001 310AS002	Straight Shrink Boot Adapter Straight Shrink Boot Adapter	"A" AS50151; MIL-DTL-26482, Series 2; AS81703 Series 3; MIL-DTL-83723, Series III	B-82 B-83
AS85049/61	M85049/61	MS27332	GS85049/61 310	Potting Boot Ring	MIL-DTL-27599	B-84
AS85049/62	M85049/62	M38999/2	310FS001	Straight Shrink Boot Adapter	"F" MIL-DTL-38999 Ser. I & II	B-85
AS85049/63	M85049/63	MS27670	450FA001	90° Qwik-Ty® Strain Relief	"F" MIL-DTL-38999 Ser. I & II	B-86
AS85049/69	M85049/69	MIL-C-85049/69	310HS001	Straight Shrink Boot Adapter	"H" MIL-DTL-38999 Ser. III & IV EN3645	B-87
AS85049/74	M85049/74	MS27333	GS85049/74 687	Potting Boot for Use with AS85049/61 Potting Boot Ring (Page B-84)	--	B-88
AS85049/75	M85049/75	MS27486	GS85049/75 687	Potting Boot for Use with AS85049/58 Potting Boot Ring (Page B-80)	--	B-89
AS85049/76	M85049/76	MIL-C-85049/76	390FL011	90° EMI/RFI Environmental Backshell	"F" MIL-DTL-38999 Ser. I & II	B-90
AS85049/77	M85049/77	MIL-C-85049/77	390FK011	45° EMI/RFI Environmental Backshell	"F" MIL-DTL-38999 Ser. I & II	B-91
AS85049/78	M85049/78	MIL-C-85049/78	390HK011	45° EMI/RFI Environmental Backshell	"H" MIL-DTL-38999 Ser. III & IV EN3645	B-92
AS85049/79	MIL-C-85049/79	390HL011	390HL011	90° EMI/RFI Environmental Backshell	"H" MIL-DTL-38999 Ser. III & IV EN3645	B-93
AS85049/80	M85049/80	MIL-C-85049/80	GS85049/80 687	Sealing Plug, Sizes 8, 12 and 16	MIL-DTL-38999	B-94

Dimensions in inches (millimeters) and are subject to change without notice.

Military Standard Backshells and Accessories Part and Page Number Index



SECTION B • AS85049 QUALIFIED PRODUCTS • SECTION B

Industry Specification Number	Part Identification Number	Military Part Number Superseded	Glenair Commercial Part Number	Description	Glenair Connector Designator/Interface	Page No.
AS85049/81	M85049/81	MIL-C-85049/81	GS85049/81 687	Sealing Plug	MIL-DTL-38999	B-96
AS85049/82 AS85049/83 AS85049/84	M85049/82 M85049/83 M85049/84	MIL-C-85049/82 MIL-C-85049/83 MIL-C-85049/84	440AS069 440AH069 440AJ069	Straight Banding Backshell 45° Banding Backshell 90° Banding Backshell	"A" AS50151; MIL-DTL-26482, Series 2; AS81703 Series 3; MIL-DTL-83723, Series III	B-97
AS85049/85 AS85049/86 AS85049/87	M85049/85 M85049/86 M85049/87	MIL-C-85049/85 MIL-C-85049/86 MIL-C-85049/87	440FS069 440FH069 440FJ069	Straight Banding Backshell 45° Banding Backshell 90° Banding Backshell	"F" MIL-DTL-38999 Series I & I	B-99
AS85049/88 AS85049/89 AS85049/90	M85049/88 M85049/89 M85049/90	MIL-C-85049/88 MIL-C-85049/89 MIL-C-85049/90	440HS069 440HH069 440HJ069	Straight Banding Backshell 45° Banding Backshell 90° Banding Backshell	"H" MIL-DTL-38999 Ser. III & IV EN3645	B-101
AS85049/91 AS85049/92	M85049/91 M85049/92	MIL-C-85049/91 MIL-C-85049/92	620HS042 620HA042	Straight Strain Relief 90° Strain Relief	"H" MIL-DTL-38999 Ser. III & IV EN3645	B-103
AS85049/93	M85049/93	MIL-C-85049/93	687-207	Banding Split Ring	---	B-104
AS85049/94	M85049/94	MIL-C-88528/1	GS85049/94 687	Full Perimeter Mounting Flange	---	B-105
AS85049/95	M85049/95	MIL-C-88528/2	GS85049/95 687	3/4 Perimeter Mounting Flange	---	B-106
AS85049/96	M85049/96	MIL-C-88528/3	GS85049/96 687	1/4 Perimeter Mounting Flange	---	B-107
AS85049/103	M85049/103	---	447HS557	Straight Shield Sock Composite Adapter with Detented or Non-Detented Self-Locking Coupling Nut	"H" MIL-DTL-38999 Ser. III & IV EN3645	B-108
AS85049/104	M85049/104	---	447HB557	45° Shield Sock Composite Adapter with Detented or Non-Detented Self-Locking Coupling Nut	"H" MIL-DTL-38999 Ser. III & IV EN3645	B-110
AS85049/105	M85049/105	---	447HA557	90° Shield Sock Composite Adapter with Detented or Non-Detented Self-Locking Coupling Nut	"H" MIL-DTL-38999 Ser. III & IV EN3645	B-112
AS85049/109	M85049/109	88064	319AS001	Straight Shield Sock Shrink Boot Adapter with Detented or Non-Detented Self-Locking or Non-Self Locking Coupling Nut	"A" AS50151; MIL-DTL-26482, Series 2; AS81703 Series 3; MIL-DTL-83723, Series III	B-114
AS85049/111	M85049/111	89018	319AJ001	90° Shield Sock Sock Shrink Boot Adapter with Optional Self-Locking Coupling Nut	"A" AS50151; MIL-DTL-26482, Series 2; AS81703 Series 3; MIL-DTL-83723, Series III	B-116
AS85049/112	M85049/112	89014	319FS001	Straight Shield Sock Sock Shrink Boot Adapter with Optional Self-Locking Coupling Nut	"F" MIL-DTL-38999 Series I & II	B-118
AS85049/114	M85049/114	89016	319FJ001	90° Shield Sock Shrink Boot Adapter with Detented or Non-Detented Self-Locking Coupling Nut	"F" MIL-DTL-38999 Series I & II	B-120
AS85049/115	M85049/115	89013	319HS001	Straight Shield Sock Shrink Boot Adapter with Optional Self-Locking Coupling Nut	"H" MIL-DTL-38999 Ser. III & IV EN3645	B-122
AS85049/118	M85049/118	---	620AS038	Straight Strain Relief, Self-Locking or Non-Self-Locking	"A" AS50151; MIL-DTL-26482, Series 2; AS81703 Series 3; MIL-DTL-83723, Series III	B-124
AS85049/120	M85049/120	---	620AA038	90° Strain Relief, Self-Locking or Non-Self-Locking	"A" AS50151; MIL-DTL-26482, Series 2; AS81703 Series 3; MIL-DTL-83723, Series III	B-126
AS85049/121	M85049/121	---	620FS038	Straight Strain Relief, Self-Locking or Non-Self-Locking	"F" MIL-DTL-38999 Series I & II; MIL-DTL-27599	B-128

Dimensions in inches (millimeters) and are subject to change without notice.



Military Standard Backshells and Accessories Part and Page Number Index

A

SECTION B • AS85049 QUALIFIED PRODUCTS • SECTION B

Industry Specification Number	Part Identification Number	Military Part Number Superseded	Glenair Commercial Part Number	Description	Glenair Connector Designator/Interface	Page No.
AS85049/123	M85049/123	--	620FA038	90° Strain Relief, Self-Locking or Non-Self-Locking	"F" MIL-DTL-38999 Series I & II; MIL-DTL-27599	B-130
AS85049/124	M85049/124	--	620HS038	Straight Strain Relief, Self-Locking or Non-Self-Locking	"H" MIL-DTL-38999 Ser. III & IV EN3645	B-132
AS85049/126	M85049/126	--	620HA038	90° Strain Relief, Self-Locking or Non-Self-Locking	"H" MIL-DTL-38999 Ser. III & IV EN3645	B-134
AS85049/127	M85049/127	--	687-581	Bushing Strip	--	B-136
AS85049/128-3 AS85049/128-4	M85049/128-3 M85049/128-4	--	600-052 600-052-1	Standard Clamping Band Precoiled Standard Clamping Band	AS85049/128	B-137
AS85049/130	M85049/130	--	Consult Factory	Gasket	--	B-138
AS85049/139	M85049/139	MS3420	GS85049/139 687	Telescoping Bushing, C or L	--	B-140
AS85049/140	M85049/140-05 M85049/140-09 M85049/140-20 M85049/140-25	MS3109	770-003S107 770-006S102W1 770-007S104 770-018S102	Straight Lipped Heat Shrink Boot Str. Lipped Long Tail Low Profile H.S. Boot Str. Lipped Mini. Long Tail Low Profile H.S. Boot Straight Lipped Sealing Heat Shrink Boot	--	B-142 B-144 B-146 B-148
AS85049/141	M85049/141-03 M85049/141-10 M85049/141-19	MS3117	770-003A105 770-006A103 770-007A103	90° Lipped Heat Shrink Boot 90° Lipped Low Profile Heat Shrink Boot 90° Lipped Mini. Low Profile Heat Shrink Boot	--	B-150 B-152 B-154
AS85049/142	M85049/142-02 M85049/142-05 M85049/142-10	--	770-011T102 770-010Y105 770-013110W1	Tee Transition Wide Body Heat Shrink Boot Wye Transition Wide Body Heat Shrink Boot 1:3 Transition Wide Body Heat Shrink Boot	--	B-156 B-158 B-160

SECTION C • MIL-DTL-38999 QUALIFIED PRODUCTS • SECTION C

Industry Specification Number	Part Identification Number	Military Part Number Superseded	Glenair Commercial Part Number	Description	Glenair Connector Designator/Interface	Page No.
MIL-DTL-38999 MIL-DTL-38999	MS27501 MS27502	MS20048 MS20047	660-012 660-013	Protective Plug Cover Protective Receptacle Cover	MIL-DTL-38999 Series I	C-2
MIL-DTL-38999	MS27510 MS27511	MS27352 MS27353	660-014 660-015	Protective Plug Cover Protective Receptacle Cover	MIL-DTL-38999 Series II	C-3
MIL-DTL-38999/22	D38999/22	--	650HS010	Dummy Storage Receptacle, Threaded Coupling	MIL-DTL-38999, Series III	C-4
MIL-DTL-38999/28	D38999/28	--	Consult Factory	Jam Nut with Safety Wire Holes	MIL-DTL-38999 Series III & IV; EN3645	C-5
MIL-DTL-38999/32 MIL-DTL-38999/33	D38999/32 D38999/33	--	660-023 660-024	Composite or Metal Threaded Plug Cover Composite or Metal Threaded Receptacle Cover	MIL-DTL-38999, Series III	C-6
MIL-DTL-38999/50	D38999/50	--	650HS007	Dummy Storage Receptacle, Bayonet Coupling	MIL-DTL-38999, Series IV	C-7

Dimensions in inches (millimeters) and are subject to change without notice.

Military Standard Backshells and Accessories Part and Page Number Index



SECTION D • MIL-DTL-28840 QUALIFIED PRODUCTS • SECTION D

Industry Specification Number	Part Identification Number	Military Part Number Superseded	Glenair Commercial Part Number	Description	Glenair Connector Designator/Interface	Page No.
MIL-DTL-28840/1	M28840/1	—	620GS051	Straight Non-Self-Locking Strain Relief	"G" MIL-DTL-28840	D-2
MIL-DTL-28840/2	M28840/2	—	620GA051	90° Non-Self-Locking Strain Relief	"G" MIL-DTL-28840	D-3
MIL-DTL-28840/3	M28840/3	—	620GB051	45° Non-Self-Locking Strain Relief	"G" MIL-DTL-28840	D-4
MIL-DTL-28840/4	M28840/4	—	—	Metal-Core Conduit	"G" MIL-DTL-28840	D-5
MIL-DTL-28840/5	M28840/5	—	—	Straight Backshell for Metal-Core Conduit	"G" MIL-DTL-28840	D-6
MIL-DTL-28840/6	M28840/6 A M28840/6 B	—	390AB001 370 Series	Strt. EMI/RFI Environmental Backshell, Style A Straight Environmental Backshell, Style B	"G" MIL-DTL-28840	D-7 D-8
MIL-DTL-28840/7	M28840/7	—	650GS001	Dummy Storage Receptacle, Threaded Coupling	"G" MIL-DTL-28840	D-9
MIL-DTL-28840/8	M28840/8- M28840/8 A	—	390-061	90° Environmental Backshell, Style A 90° EMI/RFI Environmental Backshell, Style B	"G" MIL-DTL-28840	D-10 D-11
MIL-DTL-28840/9	M28840/9 B M28840/9 A	—	390-061	45° Environmental Backshell, Style A 45° EMI/RFI Environmental Backshell	"G" MIL-DTL-28840	D-12 D-13
MIL-DTL-28840/13 MIL-DTL-28840/15	M28840/13 M28840/15	—	660-011 660-010	Protective Threaded Receptacle Cover Protective Threaded Plug Cover	MIL-DTL-28840	D-14
MIL-DTL-28840/22	M28840/22	—	—	Metal-Core Conduit Bushing	"G" MIL-DTL-28840	D-15
MIL-DTL-28840/23	M28840/23	—	Consult Factory	E Nut, Non-Self-Locking	"G" MIL-DTL-28840	D-16
MIL-DTL-28840/24	M28840/24	—	Consult Factory	Gasket	"G" MIL-DTL-28840	D-17

SECTION E • MIL-DTL-83723 QUALIFIED PRODUCTS • SECTION E

Industry Specification Number	Part Identification Number	Military Part Number Superseded	Glenair Commercial Part Number	Description	Glenair Connector Designator/Interface	Page No.
MIL-DTL-83723/27	M83723/27M	—	310KS002	Straight Shrink Boot Adapter	"K" MIL-DTL-83723 Series II	E-2
MIL-DTL-83723/35	M83723/35S M83723/35A M83723/35N	—	Consult Factory	Strt. Non-Environmental Strain Relief Backshell 90° Non-Environmental Strain Relief Backshell Non-Self-Locking E-Nut	"K" MIL-DTL-83723 Series II	E-3 E-4 E-5
MIL-DTL-83723/50	M83723/50 R M83723/50 B M83723/50 A	—	Consult Factory	Straight Qwik-Ty® Strain Relief 45° Qwik-Ty® Strain Relief 90° Qwik-Ty® Strain Relief	"K" MIL-DTL-83723 Series II	E-6
MIL-DTL-83723/59 MIL-DTL-83723/60	M83723/59-1 M83723/60-1	MS27292 MS27293	660-021 660-022	Protective Plug Cover, Threaded Coupling Protective Receptacle Cover, Threaded Coupling	MIL-DTL-83723, Series III	E-7
MIL-DTL-83723/59 MIL-DTL-83723/60	M83723/59-2 M83723/60-2	MS27294 MS27295	660-019 660-020	Protective Plug Cover Bayonet Coupling Protective Receptacle Cover Bayonet Coupling	MIL-DTL-83723, Series III	E-8
MIL-DTL-83723/70	M83723/70	—	Consult Factory	Straight Quick Disconnect Receptacle Adapter	—	E-9

Dimensions in inches (millimeters) and are subject to change without notice.
Mil-Spec Backshells and Accessories

Rev. 5/30/14

© 2013 Glenair, Inc.

U.S. CAGE Code 06324

Printed in U.S.A.



Military Standard Backshells and Accessories Part and Page Number Index

A

SECTION F • AS81511 QUALIFIED PRODUCTS • SECTION F

Industry Specification Number	Part Identification Number	Military Part Number Superseded	Glenair Commercial Part Number	Description	Glenair Connector Designator/Interface	Page No.
AS81511/13	M81511/13	—	620JS001	Straight Non-Self-Locking Strain Relief	"J" AS81511 Series I, II, III & IV	F-2
AS81511/14	M81511/14 A M81511/14 B	—	390JS012 390JS012	Straight EMI/RFI Environmental Backshell A Straight EMI/RFI Environmental Backshell B	"J" AS81511 Series I, II, III & IV	F-3
AS81511/14	M81511/14 C M81511/14 D	—	380JS008 380JS008	Str. EMI/RFI Non-Environmental Backshell C Str. EMI/RFI Non-Environmental Backshell D	"J" AS81511 Series I, II, III & IV	F-5
AS81511/17 AS81511/18	M81511/17 M81511/18	—	660-017 660-018	Protective Plug Cover Protective Receptacle Cover	AS81511 Series I, II, III & IV	F-7
AS81511/19	M81511/19	—	650JS002	Dummy Storage Receptacle	AS81511 Series I, II, III & IV	F-8
AS81511/20	M81511/20	—	Consult Factory	Jam Nut	AS81511 Series I, II, III & IV	F-9
AS81511/29	M81511/29	—	660-016	Protective Plug Cover	AS81511 Series I, II, III & IV	F-7
AS81511/30	M81511/30	—	650JS001	Dummy Storage Receptacle Bayonet Coupling	MIL-DTL-26500 and MIL-DTL-83723, Series III	F-10

SECTION G • MISCELLANEOUS QUALIFIED PRODUCTS • SECTION G

Industry Specification Number	Part Identification Number	Military Part Number Superseded	Glenair Commercial Part Number	Description	Glenair Connector Designator/Interface	Page No.
AS25042 AS25043	MS25042 MS25043	MS25042 MS25043	660-004 660-005	Threaded Protective Plug Cover Threaded Protective Receptacle Cover	AS50151	G-2
MS17349 MS17350	MS17349 MS17350	—	660-007 660-006	Threaded Protective Receptacle Cover Threaded Protective Plug Cover	MIL-DTL-22992	G-3
MS27291	MS27291	—	620ES050	Straight Non-Self-Locking Strain Relief	"E" MIL-DTL-26500	G-4
MIL-DTL-26500	MS27558	—	G2221-A	90° Non-Self-Locking Strain Relief	"E" MIL-DTL-26500	G-5
MIL-DTL-26500	MS27559	—	G2221-B	90° Non-Self-Locking Strain Relief	"E" MIL-DTL-26500	G-6
—	MS27741	—	410-003	TAG® Ring for Reliable Terminations	—	G-7
AS50151	MS3105	—	650BS001	Dummy Storage Receptacle, Threaded Coupling	AS50151	G-8
—	MS3115	—	650DS001	Dummy Storage Receptacle, Bayonet Coupling	MIL-DTL-26482	G-9
—	MS3180 MS3181	—	660-008 660-009	Protective Plug Cover, Bayonet Coupling Protective Receptacle Cover, Bayonet Coupling	MIL-DTL-26482	G-10
—	MS27512	MS3186	Consult Factory	Jam Nut with Safety Wire Holes	AS50151; MIL-DTL-26482; MIL-DTL-26500; MIL-DTL-83723 Series I; MIL-DTL-83723, Series III MIL-DTL-38999 Series I; MIL-DTL-38999 Series II; MIL-DTL-28840; MIL-DTL-27599	G-11
—	M29504/04	—	Consult Factory	Fiber Optic Pin Terminus, Size 16	MIL-DTL-29504	G-13
—	M29504/05	—	Consult Factory	Fiber Optic Socket Terminus, Size 16	MIL-DTL-29504	G-14
MIL-DTL-83513/05	M83513/05	—	Consult Factory	Micro-D Jackscrew Kits	MIL-DTL-83513/05	G-15
MIL-DTL-83538/9	M83538/9S	—	Consult Factory	Straight Adapter and Extender	MIL-DTL-83538/4	G-16
MIL-S-81824/1	M81824/1	—	070-001	In-Line Splice, Insulated and Environmental	—	G-17

Dimensions in inches (millimeters) and are subject to change without notice.

Military Standard Backshells and Accessories Part and Page Number Index



SECTION H • GLENAIR QUALIFIED TOOLS • SECTION H

Industry Specification Number	Part Identification Number	Military Part Number Superseded	Glenair Commercial Part Number	Description	Glenair Connector Designator/Interface	Page No.
--	--	--	TG37	Connector Wrench for MIL-DTL-26500 and MIL-DTL-83723 Series III	MIL-DTL-26500; MIL-DTL-83723 Series III	H-2
--	MS3481	--	TG39	Connector Wrench for MIL-DTL-26482, Ser. I & II; MIL-DTL-83723, Ser. I & NAS 1599	MIL-DTL-26482 Series I & II; MIL-DTL-83723 Series I; NAS 1599	H-3
--	--	--	TG47	Connector Wrench for MIL-DTL-22992, Classes C, J and R	MIL-DTL-22992, Classes C, J and R	H-4
--	--	--	TG48	Connector Wrench for MIL-DTL-38999, Series II	MIL-DTL-38999 Series II	H-5
--	--	--	TG52	Connector Wrench for MIL-C-81511, Series II and IV	MIL-C-81511 Series II & IV	H-6
--	--	--	TG60	Connector Wrench for MIL-DTL-27599 and MIL-DTL-38999, Series I	MIL-DTL-27599; MIL-DTL-38999 Series I	H-7
--	--	--	TG83	Wrench for SJT Connectors (LN29729)	LN29729	H-8
--	--	--	TG90	Connector Wrench For MIL-DTL-38999, Ser III	MIL-DTL-38999 Series III	H-9
--	--	--	600B005	Plug and Receptacle Holder for MIL-DTL-501555 Series MS3100 Solder & Crimp and MIL-DTL-83723, Series II	MIL-DTL-50155 Series MS3100 Solder and Crimp; MIL-DTL-83723 Series II	H-10
--	--	--	600C005	Plug and Receptacle Holder for MIL-DTL-22992 Classes C, J and R	MIL-DTL-22992 Classes C, J and R	H-11
--	--	--	600D005	Plug and Receptacle Holder for MIL-DTL-26482, Series I and II, MIL-DTL-83723, Series I and NAS 1599	MIL-DTL-26482 Series I & II; MIL-DTL-83723 Series I; NAS 1599	H-12
--	--	--	600E005	Plug and Receptacle Holder for MIL-DTL-26500 and MIL-DTL-83723 Series III	MIL-DTL-26500; MIL-DTL-83723 Series III	H-13
--	--	--	600F005	Plug and Receptacle Holder for MIL-DTL-27599 and MIL-DTL-38999 Series I	MIL-DTL-27599; MIL-DTL-38999 Series I	H-14
--	--	--	600FF005	Plug and Receptacle Holder for MIL-DTL-38999, Series II	MIL-DTL-38999 Series II	H-15
--	--	--	600G005	Plug and Receptacle Holder for MIL-DTL-28840	MIL-DTL-28840	H-16
--	--	--	600H005	Plug and Receptacle Holder for MIL-DTL-38999, Series III	MIL-DTL-38999 Series III	H-17
--	--	--	600HH005	Plug and Receptacle Holder for MIL-DTL-38999, Series IV	MIL-DTL-38999 Series IV	H-18
--	--	--	600J005	Plug and Receptacle Holder for MIL-DTL-81511, Series I, II, III and IV	MIL-DTL-81511 Series I, II, III & IV	H-19

Dimensions in inches (millimeters) and are subject to change without notice.



Standard Materials, Finishes and Tolerances

A

AS85049/GLENAIR FINISH CODE CROSS-REFERENCE

AS85049 Finish Code	Material, Finish	Recommended Glenair Accessory Finish Code
A	Aluminum, Black Anodize (RoHS Compliant)	C
B	Stainless Steel, Cadmium Plate, Black	ZU
G	Aluminum, Electroless Nickel Plate (Space Grade)	MA
J	Composite, Cadmium Plate, Olive Drab	XW
L	Composite, Cadmium Plate, Olive Drab, Selective	XX
M	Composite, Electroless Nickel Plate (RoHS Compliant)	XM
N	Aluminum, Electroless Nickel Plate	M
P	Aluminum, Cadmium Plate, Olive Drab, Selective	NFP
S	Stainless Steel, Pasivate (RoHS Compliant)	Z1
T	Composite, Unplated (RoHS Compliant)	XO
W	Aluminum, Cadmium Plate, Olive Drab	NF
X	Aluminum, Nickel Fluorocarbon Polymer (RoHS Compliant)	MT
XC	Composite, Nickel Fluorocarbon Polymer (RoHS Compliant)	XMT
XS	Stainless Steel, Nickel Fluorocarbon Polymer (RoHS Compliant)	ZMT
Y	Aluminum, Pure Dense Electrodeposited Aluminum (RoHS Compliant)	AL
YC	Composite, Pure Dense Electrodeposited Aluminum (RoHS Compliant)	XAL
YL	Composite, Pure Dense Electrodeposited Aluminum, Selective (RoHS Compliant)	XAP
YP	Aluminum, Pure Dense Electrodeposited Aluminum, Selective (RoHS Compliant)	ALP
YS	Stainless Steel, Pure Dense Electrodeposited Aluminum, Selective (RoHS Compliant)	ZAL
Z	Aluminum, Zinc Nickel, Black (RoHS Compliant)	ZR
ZC	Composite, Zinc Nickel, Black (RoHS Compliant)	XZR
ZL	Composite, Zinc Nickel, Black, Selective (RoHS Compliant)	XZS
ZP	Aluminum, Zinc Nickel, Black, Selective (RoHS Compliant)	ZS
ZS	Stainless Steel, Zinc Nickel, Black (RoHS Compliant)	ZZR

Note: Every effort has been made to present accurate information in this catalog. Editorial errors that are brought to our attention will be corrected in future editions. All dimensions presented in this catalog should be confirmed by the factory prior to inclusion within designs or specifications. We are constantly incorporating product improvements and therefore Glenair reserves the right to make changes without notice.

Any liability or warranty as to quality, performance, or fitness for use of Glenair products is always based on the condition that they apply to only new, unused products that are properly stored, handled, installed, used, maintained and inspected by the user in a manner appropriate for the intended use of the product.

TOLERANCES

On all length callouts, tolerance is $\pm .060$ unless otherwise specified.

Unless otherwise specified, the following other dimensional tolerances will apply:

$$.xx = \pm .030 (.080)$$

$$.xxx = \pm .015 (0.400)$$

$$\text{Lengths} = \pm .060 (1.524)$$

$$\text{Angles} = \pm 5^\circ$$

Dimensions in inches (millimeters) and are subject to change without notice.

Recommended Torque Values



INSTALLATION TORQUE VALUES FOR CIRCULAR ELECTRICAL CONNECTOR ACCESSORIES

Shell Sizes	Group 1 Light and Medium Duty AS50151 (AS31001 Series) MIL-DTL-26482 Series I MIL-DTL-26500 MIL-DTL-27599 MIL-DTL-38999 Series I and II MIL-C-81511 Series I, II, III and IV AS81703 Series I	Group 2 Heavy Duty AS50151 (AS34001 Series) MIL-DTL-22992 MIL-DTL-26482 Series II MIL-DTL-28840 MIL-DTL-38999 Series III and IV AS81703 Series III MIL-DTL-83723 Series I, II and III	Group 2 Composite Material Coupling Threads (See Note 1)
Torque Requirements in Inch-Pounds			
8, 9, A	30/40	51/61	35
3, 10, 10SL, 11, B	30/40	71/81	35
7, 12, 12S, 13, C	35/45	103/113	45
14, 14S, 15, D	35/45	111/121	45
16, 16S, 17, E	35/45	111/121	45
18, 19, 27, F	35/45	111/121	45
20, 21, 37, G	75/85	131/141	80
22, 23, H	75/85	131/141	80
24, 25, 61, J	75/85	131/141	80
28, 29	115/125	143/153	120
32, 33	115/125	143/153	120
36	115/125	142/153	120
40	155/165	159/169	N/A
44	155/165	159/169	N/A
48	155/165	159/169	N/A

TORQUE VALUES FOR CABLE CLAMP SCREWS

Torque requirements in Inch-Pounds for corrosion resistant or steel plated screws only

Screw Size	Into Aluminum or Corrosion Resistant Steel
2-56	1.5/2.5
4-40	3.5/4.5
6-32	5.0/7.0
8-32	7.0/9.0
10-32	9.0/11.0
.250-20	11.0/13.0

1) Use Glenair 600-091 and 600-007 Torque Tools when tightening hexagonal composite accessory couplings.

2) For additional guidance or values/conditions not listed, refer to SAE AIR6151.

CABLE CLAMP WITH GROMMET - TORQUE VALUES

Torque Requirements in Inch-Pounds

Clamp Size	Torque Min/Max Values
3	30/40
4	30/40
6	35/55
8	35/55
10	35/55
12	40/60
16	40/60
20	40/60
24	80/100
28	80/100
32	80/100
40	80/100

EMI/RFI shielding terminated with conical metal ferrule(s) should employ a minimum recommended torque of 35 in-lb.

Dimensions in inches (millimeters) and are subject to change without notice.



Military Standard Connector Index

The following is a list of circular connectors defined by U.S. Military Specifications, cross-referenced to the applicable active or inactive part number series.

The symbols in the Connector Designator column are an essential element in Glenair's commercial backshell part number developments.

MILITARY STANDARD CONNECTOR INDEX				
Part No.	Connector Designator	AS50151 Specification	Series	Description
MS3100	B	AS50151	AS31001	Receptacle, Wall Mtg (Solder)
MS3101	B	AS50151	AS31001	Receptacle
MS3102	**	AS50151	AS31001	Receptacle, Box Mtg (Solder)
MS3103	**	AS50151	AS31001	Receptacle, Potting (Solder)
MS3105	**	AS50151	AS31001	Dummy Receptacle
MS3106	B	AS50151	AS31001	Plug, Straight (Solder)
MS3107	B	AS50151	AS31001	Plug, Quick Disconnect (Solder)
MS3108	B	AS50151	AS31001	Plug, 90° (Solder)
MS3110	D-729	MIL-DTL-26482	1	Receptacle, Wall Mtg
MS3111	D	MIL-DTL-26482	1	Plug, Cable Connecting
MS3112	**	MIL-DTL-26482	1	Receptacle, Box Mount
MS3113	**	MIL-DTL-26482	1	Receptacle, Solder Mtg
MS3114	D-717	MIL-DTL-26482	1	Receptacle, Jam Nut
MS3115	**	MIL-DTL-26482	1-2	Dummy Receptacle
MS3116	D	MIL-DTL-26482	1	Plug, Straight
MS3119	**	MIL-DTL-26482	1	Receptacle, Thru-Bulkhead
MS3120	D	MIL-DTL-26482	1	Receptacle, Wall Mtg (Crimp)
MS3121	D	MIL-DTL-26482	1	Plug, Straight (Crimp)
MS3122	**	MIL-DTL-26482	1	Receptacle, Box Mtg (Crimp)
MS3124	D-717	MIL-DTL-26482	1	Receptacle, Rear Mtg, Jam Nut (Crimp)
MS3126	D	MIL-DTL-26482	1	Plug, Straight (Crimp)
MS3127	**	MIL-DTL-26482	1	Receptacle, Box Mtg (Crimp)
MS3128	*	MIL-DTL-26482	1	Plug, Straight (Crimp)
MS3130	*	AS81703	1	Receptacle, Push Pull, Wide Flange
MS3132	X-706	AS81703	1	Receptacle, Push Pull, Box Mtg
MS3134	X-706	AS81703	1	Receptacle, Push Pull, Jam Nut
MS3135	**	AS81703	1	Dummy Receptacle
MS3137	X-706	AS81703	1	Plug, Straight, Push Pull
MS3138	X-706	AS81703	1	Plug, Lanyard, Push Pull
MS3139	**	AS81703	1	Receptacle, Thru-Bulkhead
MS3140	X-706B	AS81703	2	Receptacle, Push Pull, Wall Mtg
MS3142	**	AS81703	AS31001	Receptacle, Hermetic, Box Mtg
MS3143	**	AS81703	AS31001	Receptacle, Hermetic, Solder Mount
MS3144	X-706B	AS81703	2	Receptacle, Push Pull, Jam Nut
MS3145	**	AS81703	3	Receptacle, Hermetic, Push Pull, Box Mount
MS3146	**	AS81703	3	Receptacle, Push Pull, Hermetic, Solder Mount
MS3147	X-706B	AS81703	2	Plug, Push Pull (Crimp)
MS3148	X706B	AS81703	2	Plug, Push Pull, Lanyard (Crimp)
MS3149	**	AS81703	3	Receptacle, Push Pull, Hermetic

* Consult Factory
** Connector does not accommodate rear accessories.

Dimensions in inches (millimeters) and are subject to change without notice.

Military Standard Connector Index and Reference Guide



Part No.	Connector Designator	Specification	Series	Description
MS3400	A	AS50151	AS34001	Receptacle, Wall Mtg
MS3401	A	AS50151	AS34001	Receptacle, Cable Connecting
MS3402	**	AS50151	AS34001	Receptacle, Box Mtg
MS3404	A	AS50151	AS34001	Receptacle, Jam Nut
MS3406	A	AS50151	AS34001	Plug
MS3408	A	AS50151	AS34001	Plug, 90°
MS3409	A	AS50151	AS34001	Plug, 45°
MS3412	A	AS50151	AS34001	Receptacle, Wall Mtg
MS3424	A	AS81703	3	Receptacle, Push Pull, Wall Mtg
MS3440	**	MIL-DTL-26482	2	Receptacle, Narrow Flange Mtg (Was M83723/9/10)
MS3442	**	MIL-DTL-26482	2	Receptacle, Wide Flange Mtg
MS3443	**	MIL-DTL-26482	2	Receptacle, Solder Flange Mtg
MS3445	*	AS81703	2	Plug, push Pull, Rack and Panel Mtg
MS3446	A	AS81703	3	Plug, Rack and Panel
MS3449	**	MIL-DTL-26482	2	Receptacle, Single Hole Mtg
MS3450	A	AS50151	AS34501	Receptacle, Wall Mtg (Was M83723/9/10)
MS3451	A	AS50151	AS34501	Receptacle, Cable Connecting (Was M83723/19/20)
MS3452	**	AS50151	AS34501	Receptacle, Box Mtg (Was M83723/21/22)
MS3454	A	AS50151	AS34501	Receptacle, Jam Nut
MS3456	A	AS50151	AS34501	Plug, Straight (Was M83723/52/53)
MS3459	A	AS50151	AS34501	Plug, Straight, Self-Locking (Was M83723/17/18)
MS3463	**	AS81703	3	Receptacle, Push Pull
MS3464	A	AS81703	3	Receptacle, Push Pull, Jam Nut
MS3466	**	AS81703	3	Receptacle, Push Pull, Hermetic
MS3467	A	AS81703	3	Plug, Push Pull
MS3468	A	AS81703	3	Plug, Push Pull, Lanyard
MS3469	**	AS81703	3	Receptacle, Push Pull, Hermetic, Jam Nut
MS3470	A	MIL-DTL-26482	2	Receptacle, Narrow Flange Mtg (Was M83723/1/2)
MS3471	A	MIL-DTL-26482	2	Receptacle, Cable Connecting (Was M83723/7/8)
MS3472	A	MIL-DTL-26482	2	Receptacle, Wide Flange Mtg (Was M83723/3/4))
MS3473	**	MIL-DTL-26482	2	Receptacle, Solder Mtg, Hermetic
MS3474	A	MIL-DTL-26482	2	Receptacle, Rear Mtg, Jam Nut (Was M83723/5/6)
MS3475	A	MIL-DTL-26482	2	Plug, RFI Shielded (Was M83723/42/43)
MS3476	A	MIL-DTL-26482	2	Plug, Straight, (Was M83723/13/14)
MS3477	**	MIL-DTL-26482	2	Receptacle, Hermetic, Box Mtg
MS3479	**	MIL-DTL-26482	2	Receptacle, Hermetic, Rear Mtg, Jam Nut
MS17343	C	MIL-DTL-22992	R	Receptacle, Wall Mtg
MS17344	C	MIL-DTL-22992	R	Plug, Straight
MS17345	C	MIL-DTL-22992	R	Plug, Cable Connecting
MS17346	C	MIL-DTL-22992	R	Receptacle, Box Mtg
MS17347	C	MIL-DTL-22992	R	Receptacle, Jam Nut
MS17348	C	MIL-DTL-22992	R	Receptacle, Jam Nut, Box Mtg
MS18062	**	MIL-DTL-22992	R	Dummy Receptacle
MS20026	*	MIL-DTL-27599		Receptacle, Wall Mtg, Solder
MS20027	*	MIL-DTL-27599		Receptacle, Line
MS20028	*	MIL-DTL-27599		Plug, Straight
MS20029	**	MIL-DTL-27599		Receptacle, Jam Nut Mtg

* Consult Factory ** Connector does not accommodate rear accessories.

Dimensions in inches (millimeters) and are subject to change without notice.



Military Standard Connector Index and Reference Guide

A

Part No.	Connector Designator	Specification	Series	Description
MS20030	*	MIL-DTL-27599		Receptacle, Box Mtg, Hermetic
MS20031	**	MIL-DTL-27599		Receptacle, Jam Nut, Hermetic
MS20032	**	MIL-DTL-27599		Receptacle, Solder Mtg, Hermetic
MS20034	*	MIL-DTL-27599		Receptacle, Wall Mtg
MS20035	*	MIL-DTL-27599		Receptacle, Box Mtg
MS24264	E	MIL-DTL-26500	F, G & R	Receptacle, Flange Mtg
MS24265	E	MIL-DTL-26500	F, G & R	Receptacle, Single Hole Mtg
MS24266	E	MIL-DTL-26500	F, G & R	Plug, Straight
MS25183	**	AS50151	AMS31001	Plug, Potting Seal
MS27034	**	MIL-DTL-26500		Receptacle, Hermetic, Solder Mtg
MS27334	*	MIL-DTL-27599		Receptacle, Wall Mtg
MS27335	**	MIL-DTL-27599		Receptacle, Box Mtg
MS27336	*	MIL-DTL-27599		Plug, Straight
MS27337	*	MIL-DTL-27599		Receptacle, Jam Nut
MS27338	*	MIL-DTL-27599		Receptacle, Wall Mtg, Hermetic
MS27339	**	MIL-DTL-27599		Receptacle, Box Mtg, Hermetic
MS27340	**	MIL-DTL-27599		Receptacle, Jam Nut Mtg, Hermetic
MS27341	**	MIL-DTL-27599		Receptacle, Solder Mtg, Hermetic
MS27466	F	MIL-DTL-38999	I	Receptacle, Wall Mtg
MS27467	F	MIL-DTL-38999	I	Plug, Straight
MS27468	F	MIL-DTL-38999	I	Receptacle, Jam Nut
MS27469	**	MIL-DTL-38999	I	Receptacle, Wall Mtg, Hermetic
MS27470	**	MIL-DTL-38999	I	Receptacle, Jam Nut, Hermetic
MS27471	**	MIL-DTL-38999	I	Receptacle, Solder Mtg, Hermetic
MS27472	F	MIL-DTL-38999	II	Receptacle, Wall Mtg
MS27473	F	MIL-DTL-38999	II	Plug, Straight
MS27474	F	MIL-DTL-38999	II	Receptacle, Jam Nut
MS27475	F	MIL-DTL-38999	II	Receptacle, Wall Mtg
MS27476	**	MIL-DTL-38999	II	Receptacle, Box Mtg, Hermetic
MS27477	**	MIL-DTL-38999	II	Receptacle, Jam Nut, Hermetic
MS27478	**	MIL-DTL-38999	II	Receptacle, Solder Mtg, Hermetic
MS27479	F	MIL-DTL-38999	II	Inactive Use MS27472
MS27480	F	MIL-DTL-38999	II	Inactive Use MS27473
MS27481	F	MIL-DTL-38999	II	Inactive Use MS27474
MS27482	F	MIL-DTL-38999	II	Inactive Use MS27475
MS27483	**	MIL-DTL-38999	II	Inactive Use MS27477
MS27484P	**	MIL-DTL-38999	II	Plug, Straight
MS27484T	F	MIL-DTL-38999	II	Plug, Straight
MS27496	**	MIL-DTL-38999	I	Receptacle, Box Mtg
MS27497	F	MIL-DTL-38999	II	Receptacle, Back Panel Wall Mtg
MS27498	F	MIL-DTL-38999	I	Plug, 90°
MS27499	**	MIL-DTL-38999	II	Receptacle, Box Mtg
MS27500	F	MIL-DTL-38999	II	Inactive See MS27473
MS27503	**	MIL-DTL-38999	II	Inactive See MS27478
MS27504	**	MIL-DTL-38999	II	Inactive See MS27499
M81511/23	J	AS81511	1	Receptacle, Jam Nut
M81511/24	**	AS-81511	1	Receptacle, Jam Nut

* Consult Factory ** Connector does not accommodate rear accessories.

Dimensions in inches (millimeters) and are subject to change without notice.

Military Standard Connector Index and Reference Guide



Part No.	Connector Designator	Specification	Series	Description
MS27505	**	MIL-DTL-38999	I	Receptacle, Back Panel Box Mtg
MS27508	**	MIL-DTL-38999	II	Receptacle, Back Panel Box Mtg
MS27513	**	MIL-DTL-38999	II	Receptacle, Box Mtg
MS27515	F	MIL-DTL-38999	I	Inactive Use MS27656
MS27613	E-710	MIL-DTL-26500K		Receptacle, Panel Mtg
MS27614	E-710	MIL-DTL-26500K		Receptacle, D-Hole Mtg
MS27615	E-710	MIL-DTL-26500K		Plug, Straight
MS27652	F	MIL-DTL-38999	I	Inactive Use MS27466
MS27653	F	MIL-DTL-38999	I	Inactive Use MS27467
MS27654	F	MIL-DTL-38999	I	Inactive Use MS27656
MS27656	F	MIL-DTL-38999	I	Receptacle, Back Panel, Wall Mtg
MS27661	F-752	MIL-DTL-38999	I	Plug, Lanyard Release
MS27662	**	MIL-DTL-38999	I	Receptacle, Thru-Bulkhead
MS27664	**	MIL-DTL-38999	II	Receptacle, Back-Panel Wall Mtg
MS27665	F	MIL-DTL-38999	I	Plug, Rack & Panel Mtg
MS27667	**	MIL-DTL-38999	II	Receptacle, Thru-Bulkhead
MS90555	*	MIL-DTL-22992	L	Receptacle, Wall Mtg
MS90556	*	MIL-DTL-22992	L	Plug, Straight
MS90557	*	MIL-DTL-22992	L	Plug, Cable Connecting
MS90558	*	MIL-DTL-22992	L	Receptacle, W/Coupling Ring, Wall Mtg
M28840/10	G	MIL-DTL-28840		Receptacle, Wall Mtg
M28840/11	G	MIL-DTL-28840		Receptacle, Cable Connecting
M28840/12	**	MIL-DTL-28840		Receptacle, Box Mtg
M28840/14	G	MIL-DTL-28840		Receptacle, Jam Nut
M28840/16	G	MIL-DTL-28840		Plug, Straight
D38999/20	H	MIL-DTL-38999	III	Receptacle, Wall Mtg
D38999/21	**	MIL-DTL-38999	III	Receptacle, Hermetic
D38999/23	**	MIL-DTL-38999	III	Receptacle, Hermetic, Jam Nut
D38999/24	H	MIL-DTL-38999	III	Receptacle, Jam Nut
D38999/25	**	MIL-DTL-38999	III	Receptacle, Hermetic, Solder Mtg
D38999/26	H	MIL-DTL-38999	III	Plug, Straight
D38999/27	**	MIL-DTL-38999	III	Receptacle, Hermetic, Weld Mtg
D38999/29	*	MIL-DTL-38999	III	Plug, Lanyard Release
D38999/30	H-701	MIL-DTL-38999	III	Plug, Lanyard Release
D38999/40	H	MIL-DTL-38999	IV	Receptacle, Wall Mtg
D38999/42	H	MIL-DTL-38999	IV	Receptacle, Box Mtg
D38999/44	H-715	MIL-DTL-38999	IV	Receptacle, Jam Nut
D38999/46	H	MIL-DTL-38999	IV	Plug, Straight, EMI
D38999/47	H	MIL-DTL-38999	IV	Plug, Straight
M81511/1	J	AS81511	2	Receptacle, Flange Mtg
M81511/2	**	AS81511	2	Receptacle, Solder Flange
M81511/3	J	AS81511	2	Receptacle, Jam Nut
M81511/4	**	AS81511	2	Receptacle, Jam Nut
M81511/5	J	AS81511	2	Plug, Cable Connecting
M81511/6	J	AS81511	2	Plug
M81511/21	J	AS81511	1	Receptacle, Flange Mtg
M81511/22	**	AS81511	1	Receptacle, Solder Flange Mtg

* Consult Factory ** Connector does not accommodate rear accessories.

Dimensions in inches (millimeters) and are subject to change without notice.

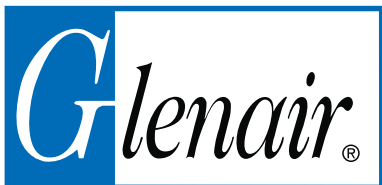

Military Standard Connector Index and Reference Guide

A

Part No.	Connector Designator	Specification	Series	Description
M81511/23	J	AS81511	1	Receptacle, Jam Nut
M81511/24	**	AS81511	1	Receptacle, Jam Nut
M81511/25	J	AS81511	1	Receptacle, Cable Connecting
M81511/26	J	AS81511	1	Plug
M81511/27	**	AS81511	1	Receptacle Thru-Bulkhead, Jam Nut
M81511/28	**	AS81511	2	Receptacle, Thru-Bulkhead, Single Hole Mtg
M81511/31	J	AS81511	2	Receptacle, Flange Mtg
M81511/32	J	AS81511	2	Receptacle, Jam Nut Mtg
M81511/33	J	AS81511	2	Receptacle, Cable Connecting
M81511/34	J	AS81511	2	Plug
M81511/35	J	AS81511	1	Receptacle, Flange Mtg
M81511/36	J	AS81511	1	Receptacle, Jam Nut
M81511/37	J	AS81511	1	Receptacle, Cable Connecting
M81511/38	J	AS81511	1	Plug
M81511/41	J	AS81511	3	Receptacle, Flange Mtg
M81511/42	**	AS81511	3	Receptacle, Solder Flange Mtg
M81511/44	**	AS81511	3	Receptacle, Jam Nut
M81511/45	J	AS81511	3	Receptacle, Cable Connecting
M81511/46	J	AS81511	3	Plug
M81511/47	**	AS81511	3	Receptacle, Solder Flange Mtg
M81511/48	**	AS81511	3	Receptacle, Jam Nut
M81511/49	J	AS81511	3	Receptacle, Jam Nut
M81511/50	**	AS81511	4	Receptacle, Jam Nut
M81511/51	J	AS81511	4	Receptacle, Flange Mtg
M81511/52	**	AS81511	4	Receptacle, Solder Flange Mtg
M81511/53	J	AS81511	4	Receptacle, Jam Nut
M81511/54	**	AS81511	4	Receptacle, Jam Nut
M81511/55	J	AS81511	4	Receptacle, Cable Connecting
M81511/56	J	AS81511	4	Plug
M81511/57	**	AS81511	4	Receptacle, Solder Flange Mtg
M81582/1	*	MIL-C-81582		Receptacle, Single Hole Mtg
M81582/2	*	MIL-C-81582		Plug, Lanyard Release
M83723/1	A	MIL-DTL-83723	I	Superseded by MS3470
M83723/2	A	MIL-DTL-83723	I	Superseded by MS3470
M83723/3	A	MIL-DTL-83723	I	Superseded by MS3472
M83723/4	A	MIL-DTL-83723	I	Superseded by MS3472
M83723/5	A	MIL-DTL-83723	I	Superseded by MS3474
M83723/6	A	MIL-DTL-83723	I	Superseded by MS3474
M83723/7	A	MIL-DTL-83723	I	Superseded by MS3471
M83723/8	A	MIL-DTL-83723	I	Superseded by MS3471
M83723/9	**	MIL-DTL-83723	I	Superseded by MS3440
M83723/10	**	MIL-DTL-83723	I	Superseded by MS3442
M83723/11	**	MIL-DTL-83723	I	Superseded by MS3443
M83723/12	**	MIL-DTL-83723	I	Superseded by MS3443
M83723/13	A	MIL-DTL-83723	I	Superseded by MS3476
M83723/14	A	MIL-DTL-83723	I	Superseded by MS3476
M83723/17	K	MIL-DTL-83723	II	Superseded by MS3451

* Consult Factory ** Connector does not accommodate rear accessories.

Dimensions in inches (millimeters) and are subject to change without notice.

Military Standard Connector Index and Reference Guide



Part No.	Connector Designator	Specification	Series	Description
MS27505	**	MIL-DTL-38999	I	Receptacle, Back Panel Box Mtg
MS27508	**	MIL-DTL-38999	II	Receptacle, Back Panel Box Mtg
MS27513	**	MIL-DTL-38999	II	Receptacle, Box Mtg
MS27515	F	MIL-DTL-38999	I	Inactive Use MS27656
MS27613	E-710	MIL-DTL-26500K		Receptacle, Panel Mtg
MS27614	E-710	MIL-DTL-26500K		Receptacle, D-Hole Mtg
MS27615	E-710	MIL-DTL-26500K		Plug, Straight
MS27652	F	MIL-DTL-38999	I	Inactive Use MS27466
MS27653	F	MIL-DTL-38999	I	Inactive Use MS27467
MS27654	F	MIL-DTL-38999	I	Inactive Use MS27656
MS27656	F	MIL-DTL-38999	I	Receptacle, Back Panel, Wall Mtg
MS27661	F-752	MIL-DTL-38999	I	Plug, Lanyard Release
MS27662	**	MIL-DTL-38999	I	Receptacle, Thru-Bulkhead
MS27664	**	MIL-DTL-38999	II	Receptacle, Back-Panel Wall Mtg
MS27665	F	MIL-DTL-38999	I	Plug, Rack & Panel Mtg
MS27667	**	MIL-DTL-38999	II	Receptacle, Thru-Bulkhead
MS90555	*	MIL-DTL-22992	L	Receptacle, Wall Mtg
MS90556	*	MIL-DTL-22992	L	Plug, Straight
MS90557	*	MIL-DTL-22992	L	Plug, Cable Connecting
MS90558	*	MIL-DTL-22992	L	Receptacle, W/Coupling Ring, Wall Mtg
M28840/10	G	MIL-DTL-28840		Receptacle, Wall Mtg
M28840/11	G	MIL-DTL-28840		Receptacle, Cable Connecting
M28840/12	**	MIL-DTL-28840		Receptacle, Box Mtg
M28840/14	G	MIL-DTL-28840		Receptacle, Jam Nut
M28840/16	G	MIL-DTL-28840		Plug, Straight
D38999/20	H	MIL-DTL-38999	III	Receptacle, Wall Mtg
D38999/21	**	MIL-DTL-38999	III	Receptacle, Hermetic
D38999/23	**	MIL-DTL-38999	III	Receptacle, Hermetic, Jam Nut
D38999/24	H	MIL-DTL-38999	III	Receptacle, Jam Nut
D38999/25	**	MIL-DTL-38999	III	Receptacle, Hermetic, Solder Mtg
D38999/26	H	MIL-DTL-38999	III	Plug, Straight
D38999/27	**	MIL-DTL-38999	III	Receptacle, Hermetic, Weld Mtg
D38999/29	*	MIL-DTL-38999	III	Plug, Lanyard Release
D38999/30	H-701	MIL-DTL-38999	III	Plug, Lanyard Release
D38999/40	H	MIL-DTL-38999	IV	Receptacle, Wall Mtg
D38999/42	H	MIL-DTL-38999	IV	Receptacle, Box Mtg
D38999/44	H-715	MIL-DTL-38999	IV	Receptacle, Jam Nut
D38999/46	H	MIL-DTL-38999	IV	Plug, Straight, EMI
D38999/47	H	MIL-DTL-38999	IV	Plug, Straight
M81511/1	J	AS81511	2	Receptacle, Flange Mtg
M81511/2	**	AS81511	2	Receptacle, Solder Flange
M81511/3	J	AS81511	2	Receptacle, Jam Nut
M81511/4	**	AS81511	2	Receptacle, Jam Nut
M81511/5	J	AS81511	2	Plug, Cable Connecting
M81511/6	J	AS81511	2	Plug
M81511/21	J	AS81511	1	Receptacle, Flange Mtg
M81511/22	**	AS81511	1	Receptacle, Solder Flange Mtg

* Consult Factory ** Connector does not accommodate rear accessories.

Dimensions in inches (millimeters) and are subject to change without notice.



Military Standard Connector Index and Reference Guide

A

Part No.	Connector Designator	Specification	Series	Description
M83723/94	**	MIL-DTL-83723	III	Receptacle, Bayonet, Single Hole Mtg., Hermetic
M83723/95	A	MIL-DTL-83723	III	Plug, Threaded, Socket Contact, Self-Locking
M83723/96	A	MIL-DTL-83723	III	Plug, Threaded, Pin Contact, Self-Locking
M83723/97	A	MIL-DTL-83723	III	Plug, Threaded, RFI, Socket Contact, Self-Locking
M83723/98	A	MIL-DTL-83723	III	Plug, Threaded, Pin Contact, Self-Locking
NATC00	H*	SSQ221635		Receptacle, Flange
NATC06	H*	SSQ221635		Plug
NATC07	H*	SSQ221635		Receptacle, Jam Nut
NATC09	***	SSQ221635		Receptacle, Weld Mtg.
NATC77	***	SSQ221635		Receptacle, Jam Nut
NATC99	***	SSQ221635		Receptacle, Weld Mtg.
NBO	A	40M39569		Receptacle, Flange Mtg.
NBOH	**	40M39569		Receptacle, Hermetic
NB3H	**	40M39569		Receptacle, Hermetic
NB4	A	40M39569		Receptacle, Flange Mtg.
NB5H	**	40M39569		Through-Bulkhead, Hermetic
NB6	A	40M39569		Plug, Straight
NB6G	A	40M39569		Plug, Straight, EMI
NB7	A	40M39569		Receptacle, Jam Nut
NB7H	**	40M39569		Receptacle, Hermetic
NB8H	**	40M39569		Receptacle, Hermetic
NLSO	F	40M38277		Receptacle, Flange Mtg.
NLS3H	**	40M38277		Receptacle, Hermetic
NLS6	F	40M38277		Plug, Straight
NLS6G	F	40M38277		Plug, Straight, EMI
NLS7	F	40M38277		Receptacle, Jam Nut
NLS7H	**	40M38277		Receptacle, Jam Nut
NZGL00	H**	SSQ21635		Receptacle, Flange
NZGL03	***	SSQ21635		Receptacle, Lever
NZGL06	H**	SSQ21635		Plug
NZGL07	H**	SSQ21635		Receptacle, Weld Mtg
NZGL09	***	SSQ21635		Receptacle, Weld Mtg
NZGL66	H**	SSQ21635		Plug
NZGL77	***	SSQ21635		Receptacle, Jam Nut
NZGL99	***	SSQ21635		Receptacle, Weld Mtg

* Consult Factory

** Connector does not accommodate rear accessories.

H* NATC Series size 09 through 25 mates to Glenair connector designator H. Consult factory for sizes 33 and 37.

H** NZGL Series requires special accessories manufactured by Glenair. Consult factory.

*** Connector noted does not have accessory thread (NZGL and NATC hermetic/control leakage classes).

Dimensions in inches (millimeters) and are subject to change without notice.

AS85049 Qualified Backshells and Connector Accessories



AS85049

B

Part No.	Description	Page No.
AS85049/1	Straight Strain Relief	B-2
AS85049/2	Straight Environmental Strain Relief	B-3
AS85049/3	Straight Environmental Backshell	B-4-6
AS85049/4	Straight Step-Up Environmental Backshell	B-7-11
AS85049/5	Straight Step-Down Environmental Backshell	B-13-17
AS85049/6	45° RFI/EMI Environmental Backshell	B-19
AS85049/7	45° Environmental Backshell	B-21
AS85049/8	90° RFI/EMI Environmental Backshell	B-23
AS85049/9	90° Environmental Backshell	B-25
AS85049/10	Straight RFI/EMI Environmental Backshell	B-27
AS85049/11	Straight Environmental Backshell	B-31
AS85049/14	E Nuts	B-35
AS85049/15	45° Qwik-Ty® Strain Reliefs	B-36
AS85049/16	90° Qwik-Ty® Strain Reliefs	B-36
AS85049/17	Straight RFI/EMI Environmental Backshell	B-37
AS85049/18	Straight RFI/EMI Environmental Backshell	B-38
AS85049/19	Straight Environmental Backshell	B-39
AS85049/20	Straight Crimp Ring Backshell and Crimp Ring	B-41
AS85049/21	Straight Non-Environmental Strain Relief	B-42
AS85049/23	45° RFI-EMI Non-Environmental Backshell	B-43
AS85049/24	90° RFI-EMI Non-Environmental Backshell	B-45
AS85049/25	Straight RFI-EMI Non-Environmental Backshell	B-47
AS85049/26	Adapter / Crimp Ring	B-51-52
AS85049/27	E Nuts	B-53
AS85049/28	Strt. Rectangular Non-Environmental Backshell	B-54
AS85049/29	Straight Non-Environmental Strain Relief	B-55
AS85049/30	Straight RFI-EMI Shield Termination Backshell	B-56
AS85049/31	E Nuts	B-57
AS85049/33	Straight Crimp Ring Non-Env. Backshell	B-58
AS85049/34	Straight Adapter and Extender	B-59
AS85049/36	Straight RFI-EMI Non-Environmental Backshell	B-60
AS85049/37	90° RFI-EMI Non-Environmental Backshell	B-61
AS85049/38	Straight Strain Reliefs	B-62
AS85049/39	90° Strain Reliefs	B-63
AS85049/41	Straight Strain Relief	B-64
AS85049/42	Straight Strain Relief	B-65
AS85049/43	45° Strain Relief	B-66
AS85049/44	Straight Rectangular Strain Relief Backshell	B-67
AS85049/45	Straight Strain Relief	B-68
AS85049/46	90° Non-Self-Locking Composite Strain Relief	B-69
AS85049/47	90° Strain Reliefs	B-70
AS85049/48	Rectangular Strain Relief Backshell	B-71-73
AS85049/49	Straight Strain Relief	B-74
AS85049/50	Rectangular Strain Relief Backshell	B-75
AS85049/51	90° Strain Reliefs	B-76
AS85049/52	Straight Strain Reliefs	B-77

Part No.	Description	Page No.
AS85049/53 /54 /55	Qwik-Ty® Strain Reliefs	B-78
AS85049/56 /57	Qwik-Ty® Strain Reliefs	B-79
AS85049/58	Potting Boot Ring	B-80
AS85049/59	Straight Shrink Boot Adapter	B-81
AS85049/60	Straight Shrink Boot Adapters	B-82-83
AS85049/61	Potting Boot Ring	B-84
AS85049/62	Straight Shrink Boot Adapter	B-85
AS85049/63	90° Qwik-Ty® Strain Relief	B-86
AS85049/69	Straight Shrink Boot Adapter	B-87
AS85049/74	Potting Boot	B-88
AS85049/75	Potting Boot	B-89
AS85049/76	90° EMI/RFI Environmental Backshell	B-90
AS85049/77	45° EMI/RFI Environmental Backshell	B-91
AS85049/78	45° EMI/RFI Environmental Backshell	B-92
AS85049/79	90° EMI/RFI Environmental Backshell	B-93
AS85049/80	Sealing Plug, Sizes 8, 12 and 16	B-94
AS85049/81	Sealing Plug	B-96
AS85049/82 /83 /84	Banding Backshells	B-97
AS85049/85 /86 /87	Banding Backshells	B-99
AS85049/88 /89 /90	Banding Backshells	B-101
AS85049/91 /92	Strain Reliefs	B-103
AS85049/93	Banding Split Ring	B-104
AS85049/94	Full Perimeter Mounting Flange	B-105
AS85049/95	3/4 Perimeter Mounting Flange	B-106
AS85049/96	1/4 Perimeter Mounting Flange	B-107
AS85049/103	Straight Shield Sock Composite Adapter	B-108
AS85049/104	45° Shield Sock Composite Adapter	B-110
AS85049/105	90° Shield Sock Composite Adapter	B-112
AS85049/109	Straight Shield Sock Shrink Boot Adapter	B-114
AS85049/111	90° Shield Sock Sock Shrink Boot Adapter	B-116
AS85049/112	Straight Shield Sock Sock Shrink Boot Adapter	B-118
AS85049/114	90° Shield Sock Shrink Boot Adapter	B-120
AS85049/115	Straight Shield Sock Shrink Boot Adapter	B-122
AS85049/118	Straight Strain Relief	B-124
AS85049/120	90° Strain Relief	B-126
AS85049/121	Straight Strain Relief	B-128
AS85049/123	90° Strain Relief	B-130
AS85049/124	Sraight Strain Relief	B-132
AS85049/126	90° Strain Relief	B-134
AS85049/127	Bushing Strip	B-136
AS85049/128-3, -4	Clamping Bands	B-137
AS85049/130	Gasket	B-138
AS85049/139	Telescoping Bushing, C or L	B-140
AS85049/140	Straight Lipped Heat Shrink Boots	B-142-148
AS85049/141	90° Lipped Heat Shrink Boots	B-150-154
AS85049/142	Wide Body Heat Shrink Boot Transitions	B-156-160

Dimensions in inches (millimeters) and are subject to change without notice.

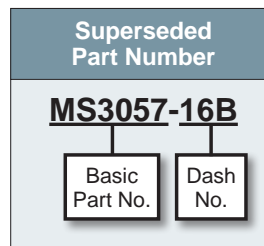
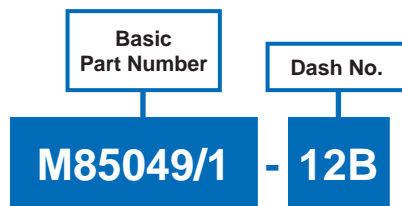

B

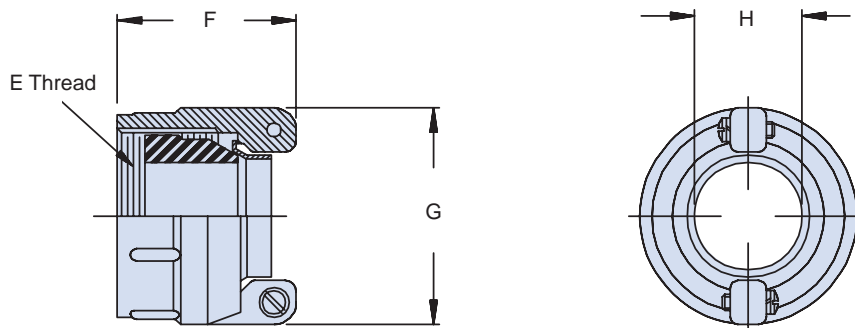
TABLE I: Shell Size, Cable Entry and Backshell Dimensions

Dash No.	Conn. Shell Ref.(s)	E Thread Class 2B	F Max		Ø G Max		H Min	
3B	8S, 10S	1/2 - 28 UNEF	1.031	(26.2)	.812	(20.6)	.231	(5.9)
4B	10SL, 12S, 12	5/8 - 24 UNEF	1.031	(26.2)	.937	(23.8)	.315	(8.0)
6B	14S, 14	3/4 - 20 UNEF	1.031	(26.2)	1.062	(27.0)	.440	(11.2)
8B	16S, 16	7/8 - 20 UNEF	1.031	(26.2)	1.188	(30.2)	.515	(13.1)
10B	18	1 - 20 UNEF	1.094	(27.8)	1.312	(33.3)	.614	(15.6)
12B	20, 22	1 3/16 - 18 UNEF	1.219	(31.0)	1.562	(39.7)	.738	(18.7)
16B	24, 28	1 7/16 - 18 UNEF	1.219	(31.0)	1.750	(44.5)	.926	(23.5)
20B	32	1 3/4 - 18 UNS	1.344	(34.1)	2.250	(57.2)	1.200	(30.5)
24B	36	2 - 18 UNS	1.547	(39.3)	2.375	(60.3)	1.363	(34.6)
28B	40	2 1/4 - 16 UN	1.547	(39.3)	2.625	(66.7)	1.611	(40.9)
32B	44	2 1/2 - 16 UN	1.734	(44.0)	2.812	(71.4)	1.865	(47.4)
40B	48	3 - 16 UN	1.781	(45.2)	3.312	(84.1)	2.365	(60.1)

APPLICATION NOTES

1. Finish on M85049/1 is Cadmium Olive Drab over Electroless Nickel (1,000 hour salt spray).
2. Assembly to be identified with manufacturer's name and part number, space permitting.
3. Cable Entry is defined as the accommodation entry for the wire bundle or cable. Dimensions are not intended for inspection criteria.
4. For complete dimensions, see the applicable Military Specification.
5. Metric dimensions (mm) are in parentheses.

Dimensions in inches (millimeters) and are subject to change without notice.

AS85049/2 and MS3057C Strain Reliefs



AS85049

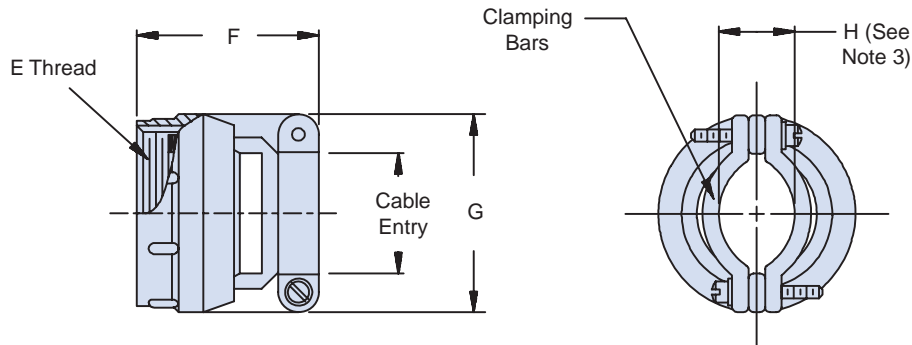
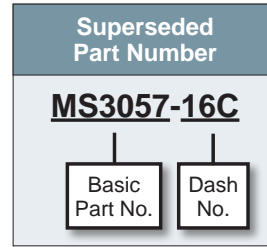
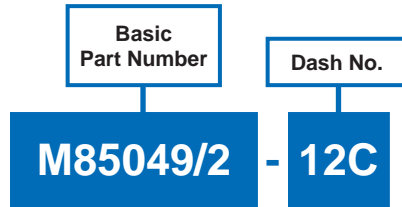

TABLE I: Shell Size, Cable Entry and Backshell Dimensions

Dash No.	Conn. Shell Ref.(s)	E Thread Class 2B	F Max	Ø G Max	H Max Closed	Cable Entry Max
3C	8S, 10S	1/2 - 28 UNEF	1.375 (34.9)	.812 (20.6)	.217 (5.5)	.219 (5.6)
4C	10SL, 12S, 12	5/8 - 24 UNEF	1.375 (34.9)	.937 (23.8)	.296 (7.5)	.312 (7.9)
6C	14S, 14	3/4 - 20 UNEF	1.375 (34.9)	1.062 (27.0)	.390 (9.9)	.438 (11.1)
8C	16S, 16	7/8 - 20 UNEF	1.375 (34.9)	1.188 (30.2)	.434 (11.0)	.531 (13.5)
10C	18	1 - 20 UNEF	1.437 (36.5)	1.312 (33.3)	.434 (11.0)	.625 (15.9)
12C	20, 22	1 3/16 - 18 UNEF	1.437 (36.5)	1.562 (39.7)	.596 (15.1)	.750 (19.1)
16C	24, 28	1 7/16 - 18 UNEF	1.562 (39.7)	1.750 (44.5)	.596 (15.1)	.938 (23.8)
20C	32	1 3/4 - 18 UNS	1.812 (46.0)	2.250 (57.2)	.858 (21.8)	1.250 (31.8)
24C	36	2 - 18 UNS	2.062 (52.4)	2.375 (60.3)	.858 (21.8)	1.375 (34.9)
28C	40	2 1/4 - 16 UN	2.062 (52.4)	2.625 (66.7)	1.107 (28.1)	1.625 (41.3)
32C	44	2 1/2 - 16 UN	2.188 (55.6)	2.812 (71.4)	1.421 (36.1)	1.875 (47.6)

APPLICATION NOTES

1. Finish on M85049/2 is Cadmium Olive Drab over Electroless Nickel, 1,000 hour salt spray.
2. Assembly to be identified with manufacturer's name and part number, space permitting.
3. Cable Entry is defined as the accommodation entry for the wire bundle or cable. Dimensions are not intended for inspection criteria.
4. For complete dimensions, see the applicable Military Specification.
5. Metric dimensions (mm) are in parentheses.

Dimensions in inches (millimeters) and are subject to change without notice.

B



AS85049/3 Style 1 Straight Environmental Backshell

CONNECTOR DESIGNATOR:

C MIL-DTL-22992 Classes C, J and R

Finish

A = Black Anodize

W = Cadmium, Olive Drab

Y = Pure Dense

Electrodeposited Aluminum

X = Nickel Fluorocarbon Polymer

Z = Zinc Nickel

TABLE II: Cable Range

Dash No.	Shell Size	Cable Range	
		Min	Max
1	12	.281 (7.1)	.375 (9.5)
2	12	.188 (4.8)	.281 (7.1)
3	14	.344 (8.7)	.438 (11.1)
4	16	.511 (13.0)	.605 (15.4)
5	16	.436 (11.1)	.530 (13.5)
6	16	.311 (7.9)	.405 (10.3)
7	18	.531 (13.5)	.625 (15.9)
8	18	.605 (15.4)	.699 (17.8)
9	18	.406 (10.3)	.500 (12.7)
10	18	.361 (9.2)	.455 (11.6)
11	20	.715 (18.2)	.828 (21.0)
12	20	.449 (11.4)	.562 (14.3)
13	22	.637 (16.2)	.750 (19.1)
14	22	.787 (20.0)	.900 (22.9)
15	22	.692 (17.6)	.805 (20.4)
16	24	.930 (23.6)	1.055 (26.8)
17	24	.675 (17.1)	1.000 (25.4)
18	24	.984 (25.0)	1.109 (28.2)
19	24	.755 (19.2)	.880 (22.4)
20	28	1.055 (26.8)	1.180 (30.0)
21	28	1.105 (28.1)	1.230 (31.2)
22	28	1.185 (30.1)	1.310 (33.3)
23	32	1.320 (33.5)	1.455 (37.0)
24	32	1.406 (35.7)	1.531 (38.9)
25	32	1.250 (31.8)	1.375 (34.9)
26	36	1.531 (38.9)	1.656 (42.1)
27	36	1.437 (36.5)	1.562 (39.7)
28	44	2.105 (53.5)	2.250 (57.2)
29	44	2.025 (51.4)	2.170 (55.1)

M85049/3

W

10

A

1

Basic
Part Number

Dash Number
(Table II)

Type
A or B

Style 1

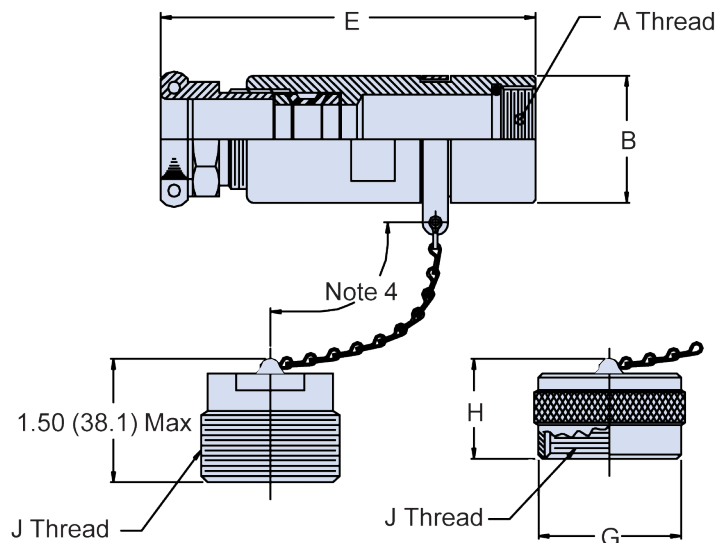

TYPE A - Plug Cap
For use with MS17344

TYPE B - Receptacle Cap
For use with MS17343,
MS17345, and MS17347

TABLE I : Shell Size and Dimensions

Shell Size	A Thread Class 2B-LH	B Dia ±.015 (0.4)	E Max	G Dia Max	H Max	J Thread (Plated) Class 2 (A or B)
12	.7500 - 20 UNEF	.933 (23.7)	3.365 (85.5)	1.094 (27.8)	.765 (19.4)	0.875-0.1P-0.2L-DS
14	.8750 - 20 UNEF	1.057 (26.8)	3.678 (93.4)	1.219 (31.0)	.765 (19.4)	1.000-0.1P-0.2L-DS
16	1.0000 - 20 UNEF	1.183 (30.0)	4.177 (106.1)	1.344 (34.1)	.980 (24.9)	1.125-0.1P-0.2L-DS
18	1.1250 - 18 UNEF	1.307 (33.2)	4.489 (114.0)	1.469 (37.3)	.980 (24.9)	1.250-0.1P-0.2L-DS
20	1.2500 - 18 UNEF	1.433 (36.4)	4.615 (117.2)	1.562 (39.7)	.980 (24.9)	1.375-0.1P-0.2L-DS
22	1.3750 - 18 UNEF	1.557 (39.5)	4.647 (118.0)	1.608 (40.8)	.980 (24.9)	1.500-0.1P-0.2L-DS
24	1.6250 - 18 UNEF	1.807 (45.9)	4.896 (124.4)	1.938 (49.2)	.980 (24.9)	1.750-0.1P-0.2L-DS
28	1.8750 - 16 UN	2.057 (52.2)	4.959 (126.0)	2.219 (56.4)	.980 (24.9)	2.000-0.1P-0.2L-DS
32	2.0625 - 16 UNS	2.307 (58.6)	5.021 (127.5)	2.469 (62.7)	.980 (24.9)	2.250-0.1P-0.2L-DS
36	2.3125 - 16 UNS	2.557 (64.9)	5.083 (129.1)	2.719 (69.1)	.980 (24.9)	2.500-0.1P-0.2L-DS
44	2.8750 - 16 UN	3.120 (79.2)	6.471 (164.4)	2.969 (75.4)	.980 (24.9)	3.000-0.1P-0.2L-DS

APPLICATION NOTES

- For complete dimensions see the applicable Military Specification. Metric dimensions (mm) are in parentheses.
- Cable Range is defined as the accommodation range for the wire bundle or cable. Dimensions shown are not intended for inspection criteria.
- Approximate chain lengths: Dash No. 01-12 = 5.0 (127.0); Dash No. 13-29 = 6.0 (152.4).

Dimensions in inches (millimeters) and are subject to change without notice.

AS85049/3 Style 2 Straight Environmental Backshell



AS85049

B

CONNECTOR DESIGNATOR:

C MIL-DTL-22992 Classes C, J and R

Finish

A = Black Anodize
 W = Cadmium, Olive Drab
 Y = Pure Dense Electrodeposited Aluminum
 X = Nickel Fluorocarbon Polymer
 Z = Zinc Nickel

M85049/3

W

10

A

2

Basic Part Number

Dash Number (Table II)

Type A or B

Style 2

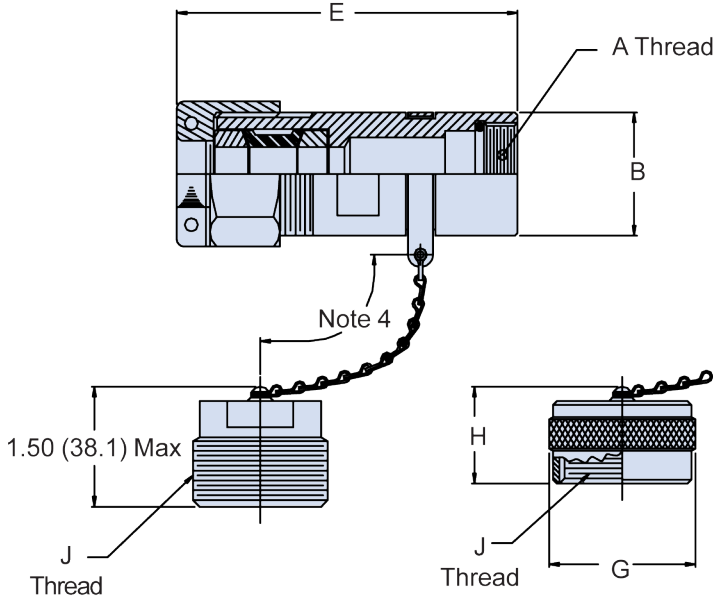

TYPE A - Plug Cap
 For use with MS17344

TYPE B - Receptacle Cap
 For use with MS17343,
 MS17345, and MS17347

TABLE II: Dash No. and Cable Range

Dash No.	Shell Size	Cable Range Min	Cable Range Max
1	12	.246 (6.2)	.396 (10.1)
2	14	.321 (8.2)	.521 (13.2)
3	16	.446 (11.3)	.646 (16.4)
4	18	.565 (14.4)	.765 (19.4)
5	20	.690 (17.5)	.890 (22.6)
6	22	.815 (20.7)	1.015 (25.8)
7	24	.980 (24.9)	1.180 (30.0)
8	28	1.230 (31.2)	1.430 (36.3)
9	28	1.030 (26.2)	1.230 (31.2)
10	32	1.430 (36.3)	1.670 (42.4)
11	36	1.660 (42.2)	1.860 (47.2)
12	40	1.860 (47.2)	2.110 (53.6)

TABLE I: Shell Size and Dimensions

Shell Size	A Thread Class 2B-LH	B Dia ±.015 (0.4)	E Max	G Dia Max	H Max	J Thread (Plated) Class 2 (A or B)
12	.7500 - 20 UNEF	.933 (23.7)	4.000 (101.6)	1.094 (27.8)	.765 (19.4)	0.875-0.1P-0.2L-DS
14	.8750 - 20 UNEF	1.057 (26.8)	4.100 (104.1)	1.219 (31.0)	.765 (19.4)	1.000-0.1P-0.2L-DS
16	1.0000 - 20 UNEF	1.183 (30.0)	4.400 (111.8)	1.344 (34.1)	.980 (24.9)	1.125-0.1P-0.2L-DS
18	1.1250 - 18 UNEF	1.307 (33.2)	4.900 (124.5)	1.469 (37.3)	.980 (24.9)	1.250-0.1P-0.2L-DS
20	1.2500 - 18 UNEF	1.433 (36.4)	4.900 (124.5)	1.562 (39.7)	.980 (24.9)	1.375-0.1P-0.2L-DS
22	1.3750 - 18 UNEF	1.557 (39.5)	4.900 (124.5)	1.688 (42.9)	.980 (24.9)	1.500-0.1P-0.2L-DS
24	1.6250 - 18 UNEF	1.807 (45.9)	5.000 (127.0)	1.938 (49.2)	.980 (24.9)	1.750-0.1P-0.2L-DS
28	1.8750 - 16 UN	2.057 (52.2)	5.300 (134.6)	2.219 (56.4)	.980 (24.9)	2.000-0.1P-0.2L-DS
32	2.0625 - 16 UNS	2.307 (58.6)	5.600 (142.2)	2.469 (62.7)	.980 (24.9)	2.250-0.1P-0.2L-DS
36	2.3125 - 16 UNS	2.557 (64.9)	5.600 (142.2)	2.719 (69.1)	.980 (24.9)	2.500-0.1P-0.2L-DS
40	2.6250 - 16 UN	2.870 (72.9)	5.725 (145.4)	2.969 (75.4)	.980 (24.9)	2.750-0.1P-0.2L-DS

APPLICATION NOTES

- For complete dimensions see the applicable Military Specification.
- Metric dimensions (mm) are in parentheses.
- Cable Range is defined as the accommodation range for the wire bundle or cable. Dimensions shown are not intended for inspection criteria.
- Approximate chain lengths: Dash No. 01-12 = 5.0 (127.0); Dash No. 13-29 = 6.0 (152.4).

Dimensions in inches (millimeters) and are subject to change without notice.

CONNECTOR DESIGNATOR:
C MIL-DTL-22992 Classes C, J and R

Finish

A = Black Anodize
W = Cadmium, Olive Drab
Y = Pure Dense Electrodeposited Aluminum
X = Nickel Fluorocarbon Polymer
Z = Zinc Nickel

TABLE II: Dash Number and Cable Range

Dash No.	Shell Size	Cable Range		F Appr. Free Length
		Min	Max	
1	12	.281 (7.1)	.377 (9.6)	3.344 (84.9)
2	12	.219 (5.6)	.281 (7.1)	1.062 (27.0)
3	14	.400 (10.2)	.438 (11.1)	4.344 (110.3)
4	16	.511 (13.0)	.605 (15.4)	5.188 (131.8)
5	16	.436 (11.1)	.530 (13.5)	4.688 (119.1)
6	16	.316 (8.0)	.405 (10.3)	3.688 (93.7)
7	18	.605 (15.4)	.699 (17.8)	6.188 (157.2)
8	18	.560 (14.2)	.625 (15.9)	6.188 (157.2)
9	18	.361 (9.2)	.455 (11.6)	4.188 (106.4)
10	20	.715 (18.2)	.828 (21.0)	6.688 (169.9)
11	20	.449 (11.4)	.562 (14.3)	5.188 (131.8)
12	22	.787 (20.0)	.900 (22.9)	7.188 (182.6)
13	22	.637 (16.2)	.750 (19.1)	6.688 (169.9)
14	24	.984 (25.0)	1.109 (28.2)	7.688 (195.3)
15	24	.875 (22.2)	1.000 (25.4)	7.188 (182.6)
16	24	.755 (19.2)	.880 (22.4)	6.688 (169.9)
17	28	1.185 (30.1)	1.310 (33.3)	8.688 (220.7)
18	28	1.105 (28.1)	1.230 (31.2)	8.188 (208.0)
19	28	1.055 (26.8)	1.180 (30.0)	8.188 (208.0)
20	32	1.406 (35.7)	1.531 (38.9)	10.688 (271.5)
21	32	1.320 (33.5)	1.455 (37.0)	9.688 (246.1)
22	32	1.250 (31.8)	1.375 (34.9)	9.688 (246.1)
23	36	1.531 (38.9)	1.656 (42.1)	12.688 (322.3)
24	36	1.437 (36.5)	1.562 (39.7)	11.188 (284.2)
25	44	2.105 (53.5)	2.250 (57.2)	17.188 (436.6)
26	44	2.025 (51.4)	2.170 (55.1)	17.188 (436.6)

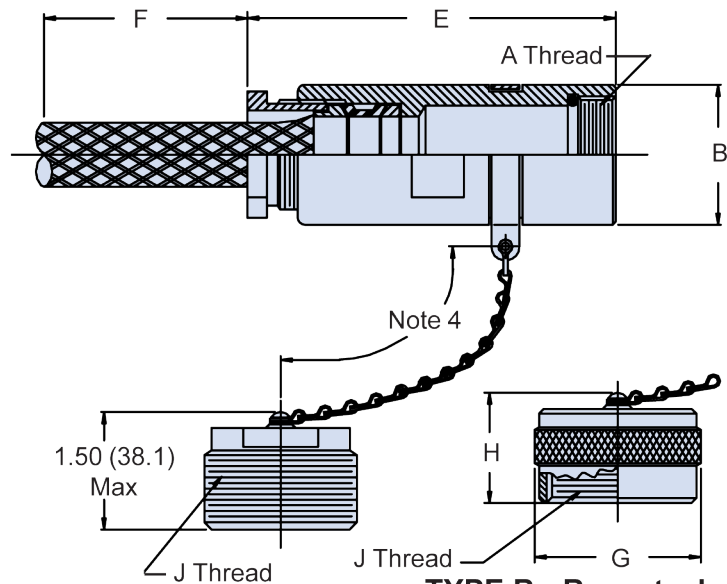
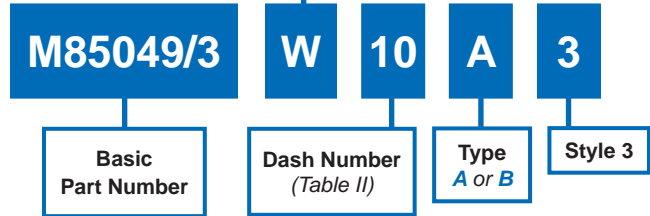
TYPE A - Plug Cap
 For use with MS17344

TYPE B - Receptacle Cap
 For use with MS17343, MS17345, and MS17347

TABLE I: Shell Size and Dimensions

Shell Size	A Thread Class 2B-LH	B Dia ±.015 (0.4)	E Max	G Dia Max	H Max	J Thread (Plated) Class 2 (A or B)
12	.7500 - 20 UNEF	.933 (23.7)	2.935 (74.5)	1.094 (27.8)	.765 (19.4)	0.875-0.1P-0.2L-DS
14	.8750 - 20 UNEF	1.057 (26.8)	3.248 (82.5)	1.219 (31.0)	.765 (19.4)	1.000-0.1P-0.2L-DS
16	1.0000 - 20 UNEF	1.183 (30.0)	3.712 (94.3)	1.344 (34.1)	.980 (24.9)	1.125-0.1P-0.2L-DS
18	1.1250 - 18 UNEF	1.307 (33.2)	4.024 (102.2)	1.469 (37.3)	.980 (24.9)	1.250-0.1P-0.2L-DS
20	1.2500 - 18 UNEF	1.433 (36.4)	4.115 (104.5)	1.562 (39.7)	.980 (24.9)	1.375-0.1P-0.2L-DS
22	1.3750 - 18 UNEF	1.557 (39.5)	4.150 (105.4)	1.688 (42.9)	.980 (24.9)	1.500-0.1P-0.2L-DS
24	1.6250 - 18 UNEF	1.807 (45.9)	4.212 (107.0)	1.938 (49.2)	.980 (24.9)	1.750-0.1P-0.2L-DS
28	1.8750 - 16 UN	2.057 (52.2)	4.275 (108.6)	2.219 (56.4)	.980 (24.9)	2.000-0.1P-0.2L-DS
32	2.0625 - 16 UNS	2.307 (58.6)	4.337 (110.2)	2.469 (62.7)	.980 (24.9)	2.250-0.1P-0.2L-DS
36	2.3125 - 16 UNS	2.557 (64.9)	4.399 (111.7)	2.719 (69.1)	.980 (24.9)	2.500-0.1P-0.2L-DS
44	2.8750 - 16 UN	3.120 (72.9)	5.799 (147.3)	3.217 (81.7)	.980 (24.9)	3.000-0.1P-0.2L-DS

APPLICATION NOTES

- For complete dimensions see the applicable Military Specification.
- Metric dimensions (mm) are in parentheses.
- Cable Range is defined as the accommodation range for the wire bundle or cable. Dimensions shown are not intended for inspection criteria.
- Approximate chain lengths: Dash No. 01-12 = 5.0 (127.0); Dash No. 13-29 = 6.0 (152.4).

Dimensions in inches (millimeters) and are subject to change without notice.

AS85049/4 Style 1 Straight Environmental Backshell



AS85049

CONNECTOR DESIGNATOR:	
C	MIL-DTL-22992 Classes C, J and R

Finish	
<i>A</i> = Black Anodize	<i>X</i> = Nickel Fluorocarbon Polymer
<i>W</i> = Cadmium, Olive Drab	<i>Z</i> = Zinc Nickel
<i>Y</i> = Pure Dense Electrodeposited Aluminum	

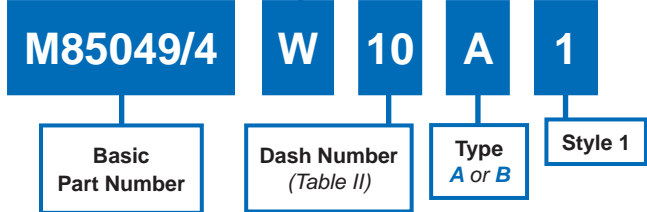

B

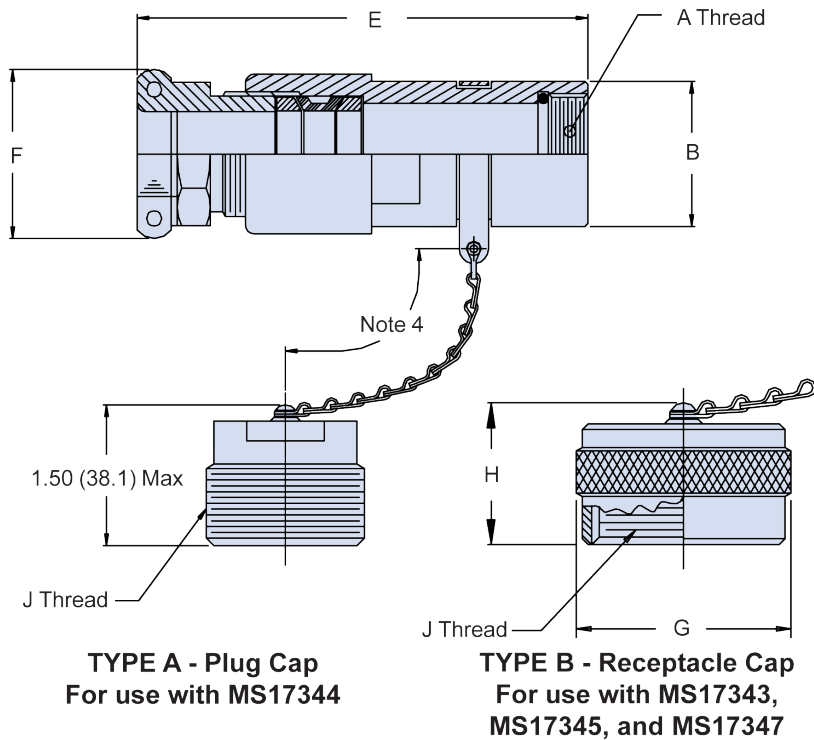

APPLICATION NOTES	
1.	For complete dimensions see the applicable Military Specification.
2.	Metric dimensions (mm) are in parentheses.
3.	Cable Range is defined as the accommodation range for the wire bundle or cable. Dimensions shown are not intended for inspection criteria.
4.	Approximate chain lengths: Dash No. 01-12 = 5.0 (127.0); Dash No. 13-29 = 6.0 (152.4).

Dimensions in inches (millimeters) and are subject to change without notice.



AS85049/4 Style 1 Straight Environmental Backshell

TABLE I: Shell Size and Dimensions

Shell Size	A Thread Class 2B-LH	B Dia ±.015 (0.4)	G Dia Max	H Max	J Thread (Plated) Class 2 (A or B)
12	.7500 - 20 UNEF	.933 (23.7)	1.094 (27.8)	.765 (19.4)	0.875-0.1P-0.2L-DS
14	.8750 - 20 UNEF	1.057 (26.8)	1.219 (31.0)	.765 (19.4)	1.000-0.1P-0.2L-DS
18	1.1250 - 18 UNEF	1.307 (33.2)	1.469 (37.3)	.980 (24.9)	1.250-0.1P-0.2L-DS
20	1.2500 - 18 UNEF	1.433 (36.4)	1.562 (39.7)	.980 (24.9)	1.375-0.1P-0.2L-DS
22	1.3750 - 18 UNEF	1.557 (39.5)	1.688 (42.9)	.980 (24.9)	1.500-0.1P-0.2L-DS
24	1.6250 - 18 UNEF	1.807 (45.9)	1.938 (49.2)	.980 (24.9)	1.750-0.1P-0.2L-DS
28	1.8750 - 16 UN	2.057 (52.2)	2.219 (56.4)	.980 (24.9)	2.000-0.1P-0.2L-DS
32	2.0625 - 16 UNS	2.307 (58.6)	2.469 (62.7)	.980 (24.9)	2.250-0.1P-0.2L-DS
36	2.3125 - 16 UNS	2.557 (64.9)	2.719 (69.1)	.980 (24.9)	2.500-0.1P-0.2L-DS
40	2.6250 - 16 UN	2.870(72.9)	2.969(75.4)	.980 (24.9)	2.750-0.1P-0.2L-DS
44	2.8750 - 16 UN	3.120 (79.2)	3.217 (81.7)	.980 (24.9)	3.000-0.1P-0.2L-DS

TABLE II: Dash Number and Cable Range

Dash No.	Shell Size	E Max	F ±.031 (0.8)	Cable Range Min Max	
1	12	4.275 (108.6)	1.375 (34.9)	.436 (11.1)	.530 (13.5)
2	12	3.678 (93.4)	1.125 (28.6)	.406 (10.3)	.500 (12.7)
3	12	4.275 (108.6)	1.375 (34.9)	.311 (7.9)	.405 (10.3)
4	14	4.177 (106.1)	1.375 (34.9)	.511 (13.0)	.605 (15.4)
5	14	4.489 (114.0)	1.562 (39.7)	.531 (13.5)	.625 (15.9)
6	14	4.177 (106.1)	1.375 (34.9)	.436 (11.1)	.530 (13.5)
7	14	4.177 (106.1)	1.375 (34.9)	.311 (7.9)	.405 (10.3)
8	18	4.584 (116.4)	1.688 (42.9)	.715 (18.2)	.828 (21.0)
9	20	4.647 (118.0)	1.812 (46.0)	.637 (16.2)	.750 (19.1)
10	20	4.896 (124.4)	2.125 (54.0)	.875 (22.2)	1.000 (25.4)
11	20	4.647 (118.0)	1.812 (46.0)	.787 (20.0)	.900 (22.9)
12	20	4.896 (124.4)	2.125 (54.0)	.930 (23.6)	1.055 (26.8)
13	22	4.896 (124.4)	2.125 (54.0)	.875 (22.2)	1.000 (25.4)
14	22	4.896 (124.4)	2.125 (54.0)	.984 (25.0)	1.109 (28.2)
15	24	4.959 (126.0)	2.469 (62.7)	1.055 (26.8)	1.180 (30.0)
16	24	4.959 (126.0)	2.469 (62.7)	1.185 (30.1)	1.310 (33.3)
17	24	4.959 (126.0)	2.469 (62.7)	1.105 (28.1)	1.230 (31.2)
18	24	4.959 (126.0)	2.625 (66.7)	1.250 (31.8)	1.375 (34.9)
19	28	5.021 (127.5)	2.625 (66.7)	1.320 (33.5)	1.445 (36.7)
20	28	5.021 (127.5)	2.625 (66.7)	1.406 (35.7)	1.531 (38.9)
21	28	5.021 (127.5)	2.625 (66.7)	1.250 (31.8)	1.375 (34.9)
22	32	5.083 (129.1)	2.953 (75.0)	1.531 (38.9)	1.656 (42.1)
23	32	5.385 (136.8)	3.171 (80.5)	1.700 (43.2)	1.828 (46.4)
24	32	5.083 (129.1)	2.953 (75.0)	1.437 (36.5)	1.562 (39.7)
25	32	5.385 (136.8)	3.171 (80.5)	1.605 (40.8)	1.730 (43.9)
26	36	5.354 (136.0)	3.171 (80.5)	1.775 (45.1)	1.900 (48.3)
27	36	5.354 (136.0)	3.171 (80.5)	1.605 (40.8)	1.730 (43.9)
28	36	5.354 (136.0)	3.171 (80.5)	1.700 (43.2)	1.825 (46.4)
29	36	5.354 (136.0)	3.171 (80.5)	1.859 (47.2)	1.984 (50.4)
30	36	5.385 (136.8)	3.375 (85.7)	1.917 (48.7)	2.062 (52.4)
31	40	5.682 (144.3)	3.625 (92.1)	2.230 (56.6)	2.375 (60.3)
32	40	5.682 (144.3)	3.500 (88.9)	2.105 (53.5)	2.250 (57.2)
33	40	5.620 (142.7)	3.375 (85.7)	2.000 (50.8)	2.145 (54.5)
34	40	5.620 (142.7)	3.375 (85.7)	1.917 (48.7)	2.062 (52.4)
35	44	6.471 (164.4)	3.531 (89.7)	2.183 (55.4)	2.328 (59.1)

Dimensions in inches (millimeters) and are subject to change without notice.

AS85049/4 Style 2 Straight Environmental Backshell



AS85049

CONNECTOR DESIGNATOR:	
C	MIL-DTL-22992 Classes C, J and R

Finish	
A = Black Anodize	X = Nickel Fluorocarbon Polymer
W = Cadmium, Olive Drab	Z = Zinc Nickel
Y = Pure Dense Electrodeposited Aluminum	

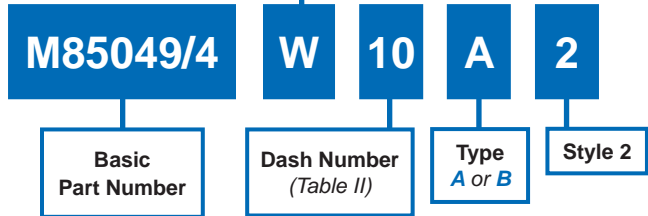

B

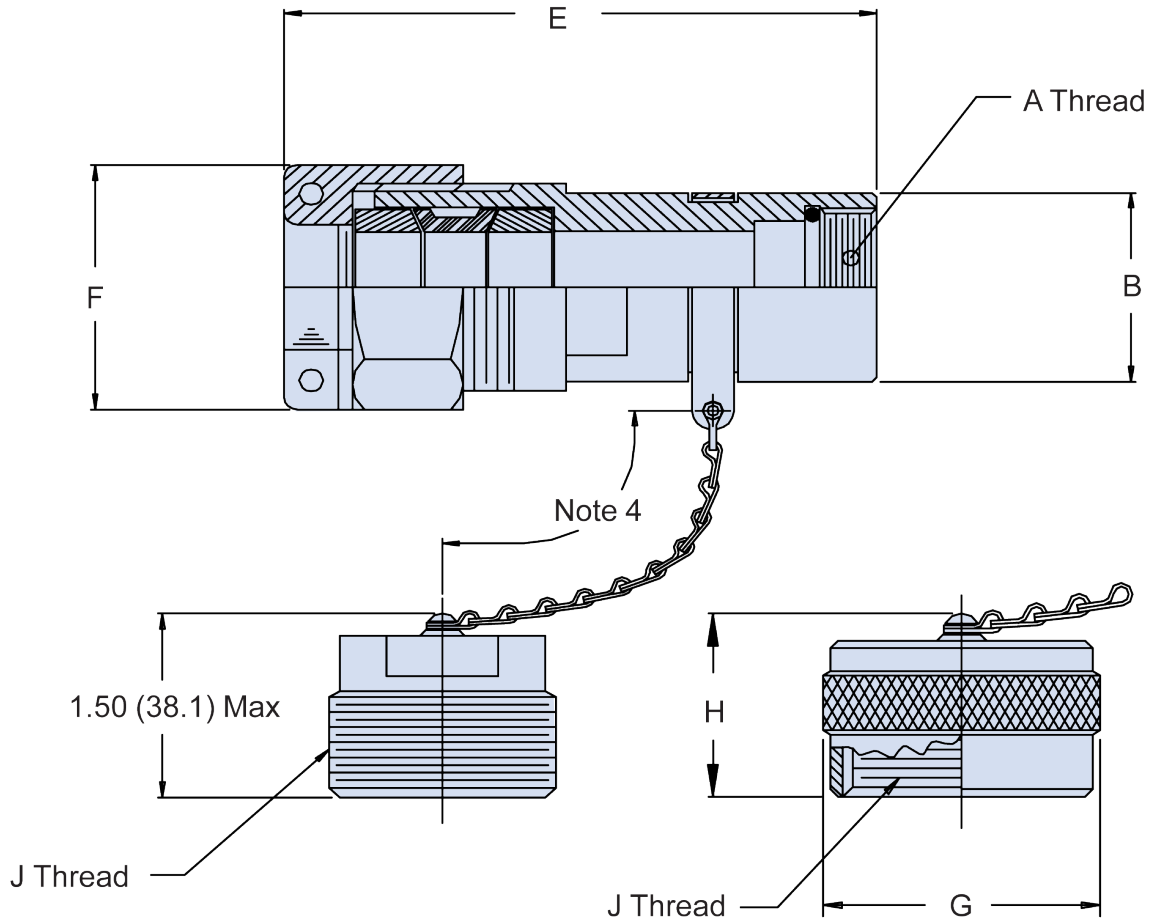

TYPE A - Plug Cap
For use with MS17344

TYPE B - Receptacle Cap
For use with MS17343,
MS17345, and MS17347

Dimensions in inches (millimeters) and are subject to change without notice.

© 2013 Glenair, Inc.

U.S. CAGE Code 06324

Printed in U.S.A.



AS85049/4 Style 2 Straight Environmental Backshell

Shell Size	A Thread Class 2B-LH	B Dia ±.015 (0.4)	E Max	G Dia Max	H Max	J Thread (Plated) Class 2 (A or B)
12	.7500 - 20 UNEF	.933 (23.7)	4.000 (101.6)	1.094 (27.8)	.765 (19.4)	0.875-0.1P-0.2L-DS
14	.8750 - 20 UNEF	1.057 (26.8)	4.100 (104.1)	1.219 (31.0)	.765 (19.4)	1.000-0.1P-0.2L-DS
16	1.0000 - 20 UNEF	1.183 (30.0)	4.400 (111.8)	1.344 (34.1)	.980 (24.9)	1.125-0.1P-0.2L-DS
18	1.1250 - 18 UNEF	1.307 (33.2)	4.900 (124.5)	1.469 (37.3)	.980 (24.9)	1.250-0.1P-0.2L-DS
20	1.2500 - 18 UNEF	1.433 (36.4)	4.900 (124.5)	1.562 (39.7)	.980 (24.9)	1.375-0.1P-0.2L-DS
22	1.3750 - 18 UNEF	1.557 (39.5)	4.900 (124.5)	1.688 (42.9)	.980 (24.9)	1.500-0.1P-0.2L-DS
24	1.6250 - 18 UNEF	1.807 (45.9)	5.000 (127.0)	1.938 (49.2)	.980 (24.9)	1.750-0.1P-0.2L-DS
28	1.8750 - 16 UN	2.057 (52.2)	5.300 (134.6)	2.219 (56.4)	.980 (24.9)	2.000-0.1P-0.2L-DS
32	2.0625 - 16 UNS	2.307 (58.6)	5.600 (142.2)	2.469 (62.7)	.980 (24.9)	2.250-0.1P-0.2L-DS
36	2.3125 - 16 UNS	2.557 (64.9)	5.600 (142.2)	2.719 (69.1)	.980 (24.9)	2.500-0.1P-0.2L-DS
40	2.6250 - 16 UN	2.870 (72.9)	5.725 (145.4)	2.969 (75.4)	.980 (24.9)	2.750-0.1P-0.2L-DS

Dash No.	Shell Size	F ± .005 (0.1)	Cable Range	
			Min	Max
1	12	1.219 (31.0)	.321 (8.2)	.521 (13.2)
2	14	1.344 (34.1)	.446 (11.3)	.646 (16.4)
3	16	1.469 (37.3)	.565 (14.4)	.765 (19.4)
4	18	1.625 (41.3)	.690 (17.5)	.890 (22.6)
5	20	1.750 (44.5)	.815 (20.7)	1.015 (25.8)
6	22	2.000 (50.8)	.980 (24.9)	1.180 (30.0)
7	24	2.250 (57.2)	1.230 (31.2)	1.430 (36.3)
8	24	2.250 (57.2)	1.030 (26.2)	1.230 (31.2)
9	28	2.500 (63.5)	1.430 (36.3)	1.670 (42.4)
10	32	2.750 (69.9)	1.660 (42.2)	1.860 (47.2)
11	36	3.062 (77.8)	1.860 (47.2)	2.110 (53.6)
12	40	3.437 (87.3)	2.200 (55.9)	2.400 (61.0)
13	40	3.437 (87.3)	2.200 (55.9)	2.200 (55.9)

APPLICATION NOTES

- For complete dimensions see the applicable Military Specification.
- Metric dimensions (mm) are in parentheses.
- Cable Range is defined as the accommodation range for the wire bundle or cable. Dimensions shown are not intended for inspection criteria.
- Approximate chain lengths: Dash No. 01-12 = 5.0 (127.0); Dash No. 13-29 = 6.0 (152.4).

Dimensions in inches (millimeters) and are subject to change without notice.

AS85049/4 Style 3 Straight Environmental Backshell



AS85049

CONNECTOR DESIGNATOR:	
C	MIL-DTL-22992 Classes C, J and R

Finish	
A = Black Anodize	X = Nickel Fluorocarbon Polymer
W = Cadmium, Olive Drab	Z = Zinc Nickel
Y = Pure Dense Electrodeposited Aluminum	

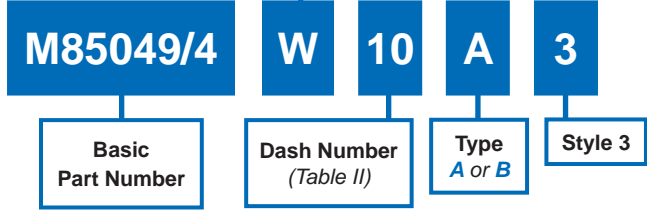

B

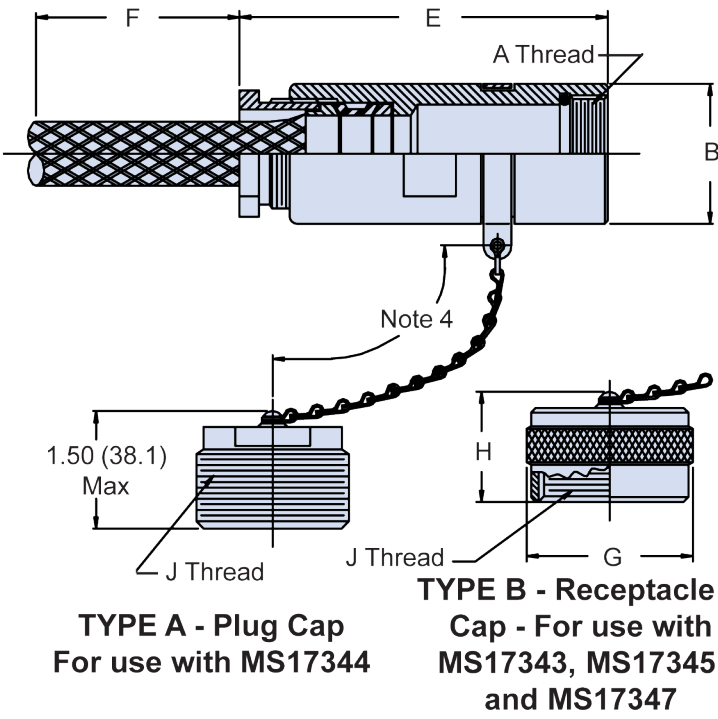

TYPE A - Plug Cap
For use with MS17344

TYPE B - Receptacle Cap - For use with MS17343, MS17345, and MS17347

APPLICATION NOTES	
1.	For complete dimensions see the applicable Military Specification.
2.	Metric dimensions (mm) are in parentheses.
3.	Cable Range is defined as the accommodation range for the wire bundle or cable. Dimensions shown are not intended for inspection criteria.
4.	Approximate chain lengths: Dash No. 01-12 = 5.0 (127.0); Dash No. 13-29 = 6.0 (152.4).

Dimensions in inches (millimeters) and are subject to change without notice.



AS85049/4 Style 3 Straight Environmental Backshell

TABLE I: Shell Size and Dimensions

Shell Size	A Thread Class 2B-LH	B Dia ±.015 (0.4)	G Dia Max	H Max	J Thread (Plated) Class 2 (A or B)
12	.7500 - 20 UNEF	.933 (23.7)	1.094 (27.8)	.765 (19.4)	0.875-0.1P-0.2L-DS
14	.8750 - 20 UNEF	1.057 (26.8)	1.219 (31.0)	.765 (19.4)	1.000-0.1P-0.2L-DS
18	1.1250 - 18 UNEF	1.307 (33.2)	1.469 (37.3)	.980 (24.9)	1.250-0.1P-0.2L-DS
20	1.2500 - 18 UNEF	1.433 (36.4)	1.562 (39.7)	.980 (24.9)	1.375-0.1P-0.2L-DS
22	1.3750 - 18 UNEF	1.557 (39.5)	1.688 (42.9)	.980 (24.9)	1.500-0.1P-0.2L-DS
24	1.6250 - 18 UNEF	1.807 (45.9)	1.938 (49.2)	.980 (24.9)	1.750-0.1P-0.2L-DS
28	1.8750 - 16 UN	2.057 (52.2)	2.219 (56.4)	.980 (24.9)	2.000-0.1P-0.2L-DS
32	2.0625 - 16 UNS	2.307 (58.6)	2.469 (62.7)	.980 (24.9)	2.250-0.1P-0.2L-DS
36	2.3125 - 16 UNS	2.557 (64.9)	2.719 (69.1)	.980 (24.9)	2.500-0.1P-0.2L-DS
40	2.6250 - 16 UN	2.870 (72.9)	2.969 (75.4)	.980 (24.9)	3.000-0.1P-0.2L-DS

TABLE II: Dash Number and Cable Range

Dash No.	Shell Size	E Max	F Appr. Free Length	Cable Range Min	Cable Range Max
1	12	3.810 (96.8)	4.688 (119.1)	.436 (11.1)	.530 (13.5)
2	12	3.248 (82.5)	4.344 (110.3)	.406 (10.3)	.500 (12.7)
3	12	3.810 (96.8)	3.688 (93.7)	.316 (8.0)	.405 (10.3)
4	14	4.024 (102.2)	6.188 (157.2)	.560 (14.2)	.625 (15.9)
5	14	3.712 (94.3)	5.188 (131.8)	.511 (13.0)	.605 (15.4)
6	14	3.712 (94.3)	4.688 (119.1)	.430 (10.9)	.530 (13.5)
7	14	3.712 (94.3)	3.688 (93.7)	.316 (8.0)	.405 (10.3)
8	18	4.087 (103.8)	6.688 (169.9)	.715 (18.2)	.828 (21.0)
9	20	4.212 (107.0)	7.688 (195.3)	.930 (23.6)	1.055 (26.8)
10	20	4.212 (107.0)	7.188 (182.6)	.875 (22.2)	1.000 (25.4)
11	20	4.150 (105.4)	7.188 (182.6)	.787 (20.0)	.900 (22.9)
12	20	4.150 (105.4)	7.188 (182.6)	.637 (16.2)	.750 (19.1)
13	22	4.212 (107.0)	7.688 (195.3)	.984 (25.0)	1.109 (28.2)
14	22	4.212 (107.0)	7.188 (182.6)	.875 (22.2)	1.000 (25.4)
15	24	4.275 (108.6)	9.688 (246.1)	1.250 (31.8)	1.375 (34.9)
16	24	4.275 (108.6)	8.688 (220.7)	1.185 (30.1)	1.310 (33.3)
17	24	4.275 (108.6)	8.188 (208.0)	1.105 (28.1)	1.230 (31.2)
18	24	4.275 (108.6)	8.188 (208.0)	1.055 (26.8)	1.180 (30.0)
19	28	4.337 (110.2)	10.688 (271.5)	1.406 (35.7)	1.531 (38.9)
20	28	4.337 (110.2)	9.688 (246.1)	1.320 (33.5)	1.445 (36.7)
21	28	4.337 (110.2)	9.688 (246.1)	1.250 (31.8)	1.375 (34.9)
22	32	4.704 (119.5)	13.688 (347.7)	1.700 (43.2)	1.825 (46.4)
23	32	4.704 (119.5)	13.688 (347.7)	1.605 (40.8)	1.730 (43.9)
24	32	4.399 (111.7)	12.688 (322.3)	1.531 (38.9)	1.656 (42.1)
25	36	4.704 (119.5)	14.188 (360.4)	1.917 (48.7)	2.062 (52.4)
26	36	4.673 (118.7)	13.688 (347.7)	1.859 (47.2)	1.984 (50.4)
27	36	4.673 (118.7)	13.688 (347.7)	1.775 (45.1)	1.900 (48.3)
28	36	4.673 (118.7)	13.688 (347.7)	1.700 (43.2)	1.825 (46.4)
29	36	4.673 (118.7)	13.688 (347.7)	1.605 (40.8)	1.730 (43.9)
30	40	5.000 (127.0)	18.188 (462.0)	2.230 (56.6)	2.375 (60.3)
31	40	5.000 (127.0)	17.188 (436.6)	2.105 (53.5)	2.250 (57.2)
32	40	4.939 (125.5)	14.188 (360.4)	2.000 (50.8)	2.145 (54.5)
33	40	4.939 (125.5)	14.188 (360.4)	1.917 (48.7)	2.062 (52.4)

Dimensions in inches (millimeters) and are subject to change without notice.

AS85049/5 Style 1 Straight Environmental Backshell



AS85049

CONNECTOR DESIGNATOR:	
C	MIL-DTL-22992 Classes C, J and R

Finish	
A = Black Anodize	X = Nickel Fluorocarbon Polymer
W = Cadmium, Olive Drab	Z = Zinc Nickel
Y = Pure Dense Electrodeposited Aluminum	

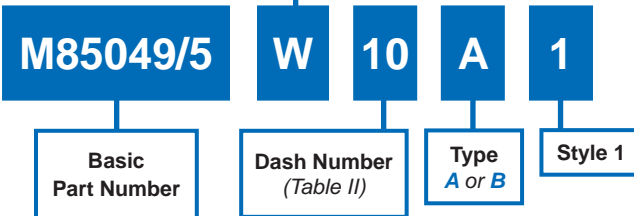

B

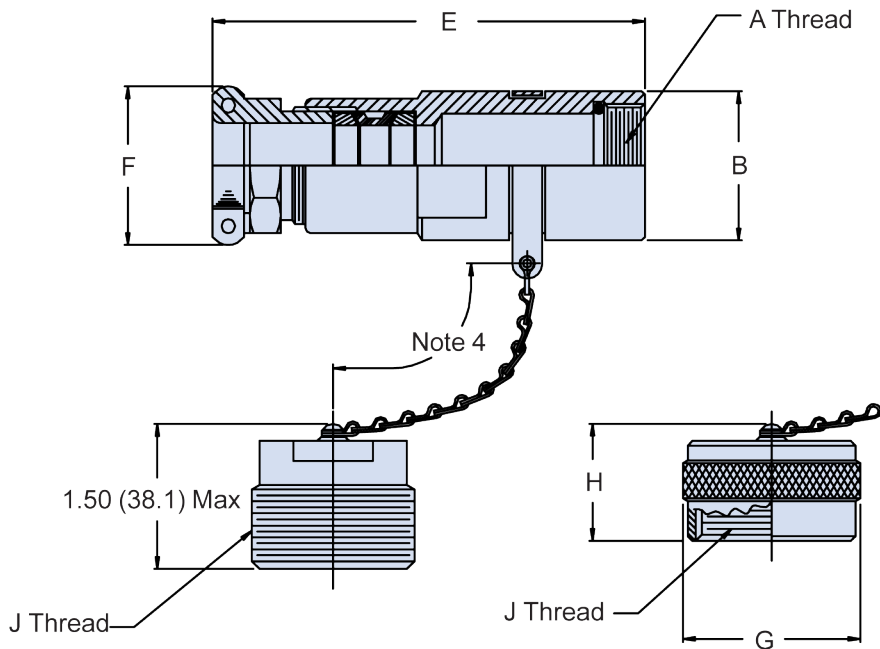

TYPE A - Plug Cap
For use with MS17344

TYPE B - Receptacle Cap
For use with MS17343,
MS17345, and MS17347

APPLICATION NOTES	
1.	For complete dimensions see the applicable Military Specification.
2.	Metric dimensions (mm) are in parentheses.
3.	Cable Range is defined as the accommodation range for the wire bundle or cable. Dimensions shown are not intended for inspection criteria.
4.	Approximate chain lengths: Dash No. 01-12 = 5.0 (127.0); Dash No. 13-29 = 6.0 (152.4).

Dimensions in inches (millimeters) and are subject to change without notice.



AS85049/5 Style 1 Straight Environmental Backshell

TABLE I: Shell Size and Dimensions

Shell Size	A Thread Class 2B-LH	B Dia ±.015 (0.4)	G Dia Max	H Max	J Thread (Plated) Class 2 (A or B)
12	.7500 - 20 UNEF	.933 (23.7)	1.094 (27.8)	.765 (19.4)	0.875-0.1P-0.2L-DS
18	1.1250 - 18 UNEF	1.307 (33.2)	1.469 (37.3)	.980 (24.9)	1.250-0.1P-0.2L-DS
20	1.2500 - 18 UNEF	1.433 (36.4)	1.562 (39.7)	.980 (24.9)	1.375-0.1P-0.2L-DS
22	1.3750 - 18 UNEF	1.557 (39.5)	1.688 (42.9)	.980 (24.9)	1.500-0.1P-0.2L-DS
24	1.6250 - 18 UNEF	1.807 (45.9)	1.938 (49.2)	.980 (24.9)	1.750-0.1P-0.2L-DS
28	1.8750 - 16 UN	2.057 (52.2)	2.219 (56.4)	.980 (24.9)	2.000-0.1P-0.2L-DS
32	2.0625 - 16 UNS	2.307 (58.6)	2.469 (62.7)	.980 (24.9)	2.250-0.1P-0.2L-DS
36	2.3125 - 16 UNS	2.557 (64.9)	2.719 (69.1)	.980 (24.9)	2.500-0.1P-0.2L-DS
40	2.6250 - 16 UN	2.870 (72.9)	2.969 (75.4)	.980 (24.9)	2.750-0.1P-0.2L-DS
44	2.8750 - 16 UN	3.120 (79.2)	3.217 (81.7)	.980 (24.9)	3.000-0.1P-0.2L-DS

TABLE II: Dash Number and Cable Range

Dash No.	Shell Size	E Max	F ± .031 (0.8)	Cable Range	
				Min	Max
1	12	3.182 (80.8)	.938 (23.8)	.156 (4.0)	.250 (6.4)
2	18	3.901 (99.1)	1.062 (27.0)	.281 (7.1)	.375 (9.5)
3	18	3.932 (99.9)	1.125 (28.6)	.281 (7.1)	.375 (9.5)
4	18	3.901 (99.1)	1.062 (27.0)	.188 (4.8)	.281 (7.1)
5	18	4.177 (106.1)	1.375 (34.9)	.511 (13.0)	.605 (15.4)
6	18	4.177 (106.1)	1.375 (34.9)	.436 (11.1)	.530 (13.5)
7	20	4.489 (114.0)	1.562 (39.7)	.605 (15.4)	.699 (17.8)
8	20	4.489 (114.0)	1.562 (39.7)	.361 (9.2)	.455 (11.6)
9	20	4.306 (109.4)	1.375 (34.9)	.511 (13.0)	.605 (15.4)
10	22	4.584 (116.4)	1.688 (42.9)	.449 (11.4)	.562 (14.3)
11	22	4.306 (109.4)	1.375 (34.9)	.311 (7.9)	.405 (10.3)
12	22	4.306 (109.4)	1.375 (34.9)	.715 (18.2)	.828 (21.0)
13	24	4.647 (118.0)	1.812 (46.0)	.787 (20.0)	.900 (22.9)
14	24	4.647 (118.0)	1.812 (46.0)	.517 (13.1)	.630 (16.0)
15	24	4.647 (118.0)	1.812 (46.0)	.637 (16.2)	.750 (19.1)
16	24	4.647 (118.0)	1.812 (46.0)	.857 (21.8)	.970 (24.6)
17	24	4.542 (115.4)	1.688 (42.9)	.715 (18.2)	.828 (21.0)
18	24	4.647 (118.0)	1.812 (46.0)	.692 (17.6)	.805 (20.4)
19	28	4.896 (124.4)	2.125 (54.0)	.755 (19.2)	.880 (22.4)
20	28	4.896 (124.4)	2.125 (54.0)	.984 (25.0)	1.109 (28.2)
21	28	4.647 (118.0)	1.812 (46.0)	.637 (16.2)	.750 (19.1)
22	28	4.229 (107.4)	1.125 (28.6)	.281 (7.1)	.375 (9.5)
23	28	4.647 (118.0)	1.812 (46.0)	.857 (21.8)	.970 (24.6)
24	28	4.896 (124.4)	2.125 (54.0)	.875 (22.2)	1.000 (25.4)
25	28	4.431 (112.5)	1.375 (34.9)	.436 (11.1)	.530 (13.5)
26	28	4.647 (118.0)	1.812 (46.0)	.567 (14.4)	.680 (17.3)
27	32	4.896 (124.4)	2.125 (54.0)	.930 (23.6)	1.055 (26.8)
28	32	4.959 (126.0)	2.469 (62.7)	1.105 (28.1)	1.230 (31.2)
29	32	4.647 (118.0)	1.812 (46.0)	.637 (16.2)	.750 (19.1)
30	32	4.896 (124.4)	2.125 (54.0)	.755 (19.2)	.880 (22.4)
31	32	4.896 (124.4)	2.125 (54.0)	.984 (25.0)	1.109 (28.2)
32	32	4.647 (118.0)	1.812 (46.0)	.857 (21.8)	.970 (24.6)
33	32	4.276 (108.6)	1.125 (28.6)	.281 (7.1)	.375 (9.5)
34	32	4.431 (112.5)	1.375 (34.9)	.436 (11.1)	.530 (13.5)
35	32	4.959 (126.0)	2.469 (62.7)	1.005 (25.5)	1.130 (28.7)
36	36	4.959 (126.0)	2.469 (62.7)	1.185 (30.1)	1.310 (33.3)
37	36	4.896 (124.4)	2.125 (54.0)	.984 (25.0)	1.109 (28.2)
38	36	5.021 (127.5)	2.625 (66.7)	1.250 (31.8)	1.375 (34.9)
39	36	4.959 (126.0)	2.469 (62.7)	1.055 (26.8)	1.180 (30.0)
40	36	5.021 (127.5)	2.625 (66.7)	1.320 (33.5)	1.445 (36.7)
41	36	4.651 (118.1)	1.812 (46.0)	.857 (21.8)	.970 (24.6)
42	36	4.959 (126.0)	2.469 (62.7)	1.105 (28.1)	1.230 (31.2)
43	40	6.354 (161.4)	3.171 (80.5)	1.815 (46.1)	1.940 (49.3)
44	40	6.354 (161.4)	3.171 (80.5)	1.700 (43.2)	1.825 (46.4)
45	40	6.354 (161.4)	3.171 (80.5)	1.605 (40.8)	1.730 (43.9)
46	40	6.057 (153.8)	2.953 (75.0)	1.531 (38.9)	1.656 (42.1)
47	44	6.345 (161.2)	3.375 (85.7)	1.867 (47.4)	2.000 (50.8)
48	44	5.266 (133.8)	3.171 (80.5)	1.775 (45.1)	1.900 (48.3)

Dimensions in inches (millimeters) and are subject to change without notice.

AS85049/5 Style 2 Straight Environmental Backshell



AS85049

CONNECTOR DESIGNATOR:	
C	MIL-DTL-22992 Classes C, J and R

A = Black Anodize	Finish	X = Nickel Fluorocarbon Polymer
W = Cadmium, Olive Drab		Z = Zinc Nickel
Y = Pure Dense Electrodeposited Aluminum		

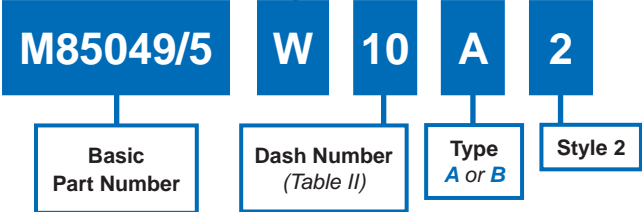

B

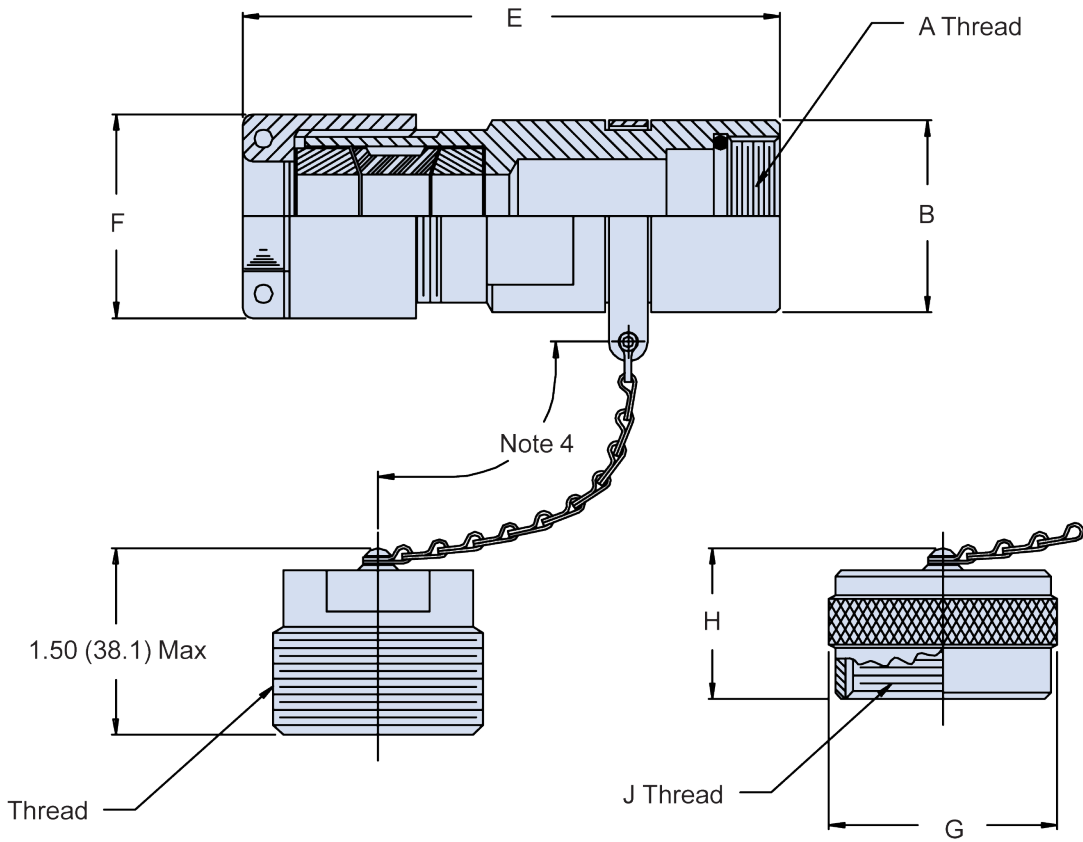

TYPE A - Plug Cap
For use with MS17344

TYPE B - Receptacle Cap
For use with MS17343,
MS17345, and MS17347

Dimensions in inches (millimeters) and are subject to change without notice.



AS85049/5 Style 2 Straight Environmental Backshell

B

TABLE I: Shell Size and Dimensions

Shell Size	A Thread Class 2B-LH	B Dia ±.015 (0.4)	E Max	G Dia Max	H Max	J Thread (Plated) Class 2 (A or B)
12	.7500 - 20 UNEF	.933 (23.7)	4.000 (101.6)	1.094 (27.8)	.765 (19.4)	0.875-0.1P-0.2L-DS
14	.8750 - 20 UNEF	1.057 (26.8)	4.100 (104.1)	1.219 (31.0)	.765 (19.4)	1.000-0.1P-0.2L-DS
16	1.0000 - 20 UNEF	1.183 (30.0)	4.400 (111.8)	1.344 (34.1)	.980 (24.9)	1.125-0.1P-0.2L-DS
18	1.1250 - 18 UNEF	1.307 (33.2)	4.600 (116.8)	1.469 (37.3)	.980 (24.9)	1.250-0.1P-0.2L-DS
20	1.2500 - 18 UNEF	1.433 (36.4)	4.900 (124.5)	1.562 (39.7)	.980 (24.9)	1.375-0.1P-0.2L-DS
22	1.3750 - 18 UNEF	1.557 (39.5)	4.900 (124.5)	1.688 (42.9)	.980 (24.9)	1.500-0.1P-0.2L-DS
24	1.6250 - 18 UNEF	1.807 (45.9)	5.000 (127.0)	1.938 (49.2)	.980 (24.9)	1.750-0.1P-0.2L-DS
28	1.8750 - 16 UN	2.057 (52.2)	5.300 (134.6)	2.219 (56.4)	.980 (24.9)	2.000-0.1P-0.2L-DS
32	2.0625 - 16 UNS	2.057 (52.2)	5.600 (142.2)	2.469 (62.7)	.980 (24.9)	2.250-0.1P-0.2L-DS
36	2.3125 - 16 UNS	2.557 (64.9)	5.600 (142.2)	2.719 (69.1)	.980 (24.9)	2.500-0.1P-0.2L-DS
40	2.6250 - 16 UN	2.870 (72.9)	5.725 (145.4)	2.969 (75.4)	.980 (24.9)	2.750-0.1P-0.2L-DS

TABLE II: Dash Number and Cable Range

Dash No.	Shell Size	F ± .031 (0.8)	Cable Range	
			Min	Max
1	12	.969 (24.6)	.130 (3.3)	.280 (7.1)
2	14	1.094 (27.8)	.246 (6.2)	.396 (10.1)
3	16	1.219 (31.0)	.321 (8.2)	.521 (13.2)
4	18	1.344 (34.1)	.446 (11.3)	.646 (16.4)
5	18	1.344 (34.1)	.300 (7.6)	.475 (12.1)
6	20	1.469 (37.3)	.565 (14.4)	.765 (19.4)
7	20	1.469 (37.3)	.400 (10.2)	.600 (15.2)
8	22	1.625 (41.3)	.690 (17.5)	.890 (22.6)
9	22	1.625 (41.3)	.500 (12.7)	.700 (17.8)
10	22	1.625 (41.3)	.400 (10.2)	.525 (13.3)
11	24	1.750 (44.5)	.815 (20.7)	1.015 (25.8)
12	24	1.750 (44.5)	.595 (15.1)	.815 (20.7)
13	28	2.000 (50.8)	.980 (24.9)	1.180 (30.0)
14	28	2.000 (50.8)	.780 (19.8)	.980 (24.9)
15	32	2.250 (57.2)	1.230 (31.2)	1.430 (36.3)
16	32	2.250 (57.2)	1.030 (26.2)	1.230 (31.2)
17	36	2.500 (63.5)	1.470 (37.3)	1.670 (42.4)
18	36	2.500 (63.5)	1.270 (32.3)	1.470 (37.3)
19	40	2.750 (69.9)	1.660 (42.2)	1.860 (47.2)
20	40	2.750 (69.9)	1.400 (35.6)	1.660 (42.2)

APPLICATION NOTES

- For complete dimensions see the applicable Military Specification.
- Metric dimensions (mm) are in parentheses.
- Cable Range is defined as the accommodation range for the wire bundle or cable. Dimensions shown are not intended for inspection criteria.
- Approximate chain lengths: Dash No. 01-12 = 5.0 (127.0); Dash No. 13-29 = 6.0 (152.4).

Dimensions in inches (millimeters) and are subject to change without notice.

AS85049/5 Style 3 Straight Environmental Backshell



AS85049

CONNECTOR DESIGNATOR:	
C	MIL-DTL-22992 Classes C, J and R

Finish	
<i>A</i> = Black Anodize	<i>X</i> = Nickel Fluorocarbon Polymer
<i>W</i> = Cadmium, Olive Drab	<i>Z</i> = Zinc Nickel
<i>Y</i> = Pure Dense Electrodeposited Aluminum	

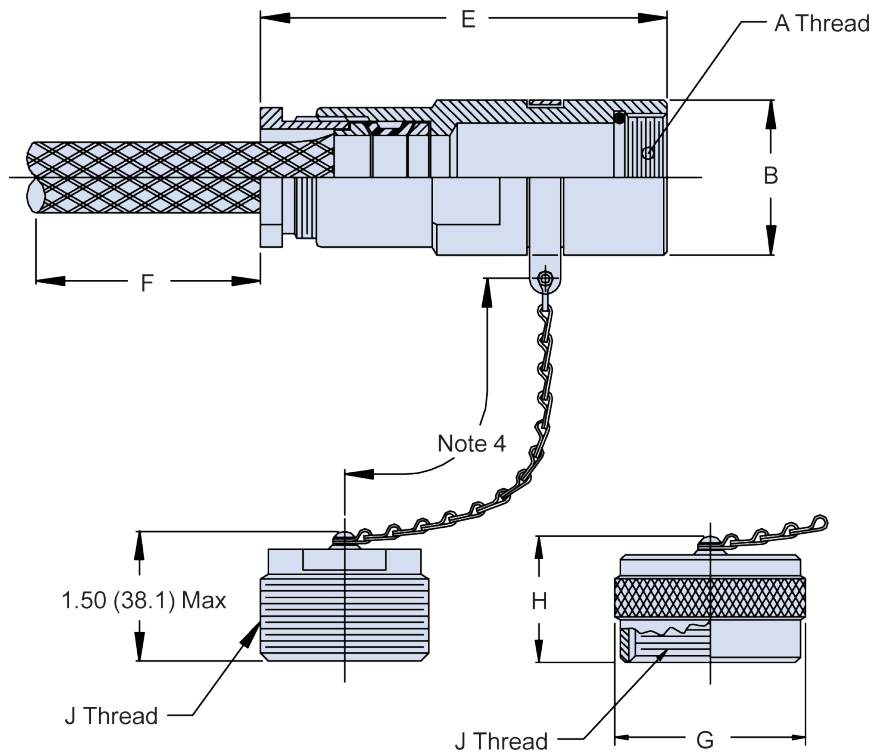
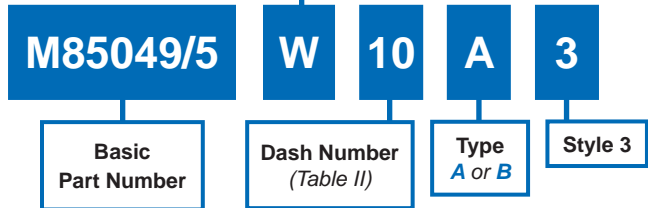

TYPE A - Plug Cap
For use with MS17344

TYPE B - Receptacle Cap
For use with MS17343,
MS17345, and MS17347

APPLICATION NOTES	
1.	For complete dimensions see the applicable Military Specification.
2.	Metric dimensions (mm) are in parentheses.
3.	Cable Range is defined as the accommodation range for the wire bundle or cable. Dimensions shown are not intended for inspection criteria.
4.	Approximate chain lengths: Dash No. 01-12 = 5.0 (127.0); Dash No. 13-29 = 6.0 (152.4).

Dimensions in inches (millimeters) and are subject to change without notice.

B



AS85049/5 Style 3 Straight Environmental Backshell

TABLE I: Shell Size and Dimensions

Shell Size	A Thread Class 2B-LH	B Dia ±.015 (0.4)	G Dia Max	H Max	J Thread (Plated) Class 2 (A or B)
12	.7500 - 20 UNEF	.933 (23.7)	1.094 (27.8)	.765 (19.4)	0.875-0.1P-0.2L-DS
18	1.1250 - 18 UNEF	1.307 (33.2)	1.469 (37.3)	.980 (24.9)	1.250-0.1P-0.2L-DS
20	1.2500 - 18 UNEF	1.433 (36.4)	1.562 (39.7)	.980 (24.9)	1.375-0.1P-0.2L-DS
22	1.3750 - 18 UNEF	1.557 (39.5)	1.688 (42.9)	.980 (24.9)	1.500-0.1P-0.2L-DS
24	1.6250 - 18 UNEF	1.807 (45.9)	1.938 (49.2)	.980 (24.9)	1.750-0.1P-0.2L-DS
28	1.8750 - 16 UN	2.057 (52.2)	2.219 (56.4)	.980 (24.9)	2.000-0.1P-0.2L-DS
32	2.0625 - 16 UNS	2.307 (58.6)	2.469 (62.7)	.980 (24.9)	2.250-0.1P-0.2L-DS
36	2.3125 - 16 UNS	2.557 (64.9)	2.719 (69.1)	.980 (24.9)	2.500-0.1P-0.2L-DS
40	2.6250 - 16 UN	2.875 (73.0)	2.969 (75.4)	.980 (24.9)	2.750-0.1P-0.2L-DS
44	2.8750 - 16 UN	3.125 (79.4)	3.217 (81.7)	.980 (24.9)	3.000-0.1P-0.2L-DS

TABLE II: Dash Number, Shell Size and Cable Range

Dash No.	Shell Size	Cable Range		E Max	F Appr. Free Length
		Min	Max		
1	12	.160 (4.1)	.222 (5.6)	2.752 (69.9)	2.406 (61.1)
2	18	.511 (13.0)	.605 (15.4)	3.712 (94.3)	5.188 (131.8)
3	18	.436 (11.1)	.530 (13.5)	3.712 (94.3)	4.688 (119.1)
4	18	.306 (7.8)	.375 (9.5)	3.502 (89.0)	3.844 (97.6)
5	18	.219 (5.6)	.281 (7.1)	3.471 (88.2)	2.844 (72.2)
6	20	.605 (15.4)	.699 (17.8)	4.024 (102.2)	6.188 (157.2)
7	20	.511 (13.0)	.605 (15.4)	3.841 (97.6)	5.188 (131.8)
8	20	.361 (9.2)	.455 (11.6)	4.024 (102.2)	4.188 (106.4)
9	22	.715 (18.2)	.828 (21.0)	4.087 (103.8)	6.688 (169.9)
10	22	.449 (11.4)	.562 (14.3)	4.087 (103.8)	5.188 (131.8)
11	22	.316 (8.0)	.405 (10.3)	3.841 (97.6)	3.688 (93.7)
12	24	.692 (17.6)	.805 (20.4)	4.150 (105.4)	6.688 (169.9)
13	24	.637 (16.2)	.750 (19.1)	4.150 (105.4)	6.688 (169.9)
14	24	.517 (13.1)	.630 (16.0)	4.150 (105.4)	5.688 (144.5)
15	28	.984 (25.0)	1.109 (28.2)	4.212 (107.0)	7.688 (195.3)
16	28	.875 (22.2)	1.000 (25.4)	4.212 (107.0)	7.188 (182.6)
17	28	.755 (19.2)	.880 (22.4)	4.212 (107.0)	6.688 (169.9)
18	28	.637 (16.2)	.750 (19.1)	4.150 (105.4)	6.688 (169.9)
19	28	.567 (14.4)	.680 (17.3)	4.150 (105.4)	6.688 (169.9)
20	28	.436 (11.1)	.530 (13.5)	3.966 (100.7)	4.688 (119.1)
21	28	.306 (7.8)	.375 (9.5)	3.799 (96.5)	3.844 (97.6)
22	32	1.105 (28.1)	1.230 (31.2)	4.275 (108.6)	8.188 (208.0)
23	32	1.005 (25.5)	1.130 (28.7)	4.275 (108.6)	7.188 (182.6)
24	32	.930 (23.6)	1.055 (26.8)	4.212 (107.0)	7.688 (195.3)
25	32	.857 (21.8)	.970 (24.6)	4.150 (105.4)	7.188 (182.6)
26	32	.755 (19.2)	.880 (22.4)	4.212 (107.0)	6.688 (169.9)
27	32	.637 (16.2)	.750 (19.1)	4.150 (105.4)	6.688 (169.9)
28	32	.436 (11.1)	.530 (13.5)	3.966 (100.7)	4.688 (119.1)
29	32	.306 (7.8)	.375 (9.5)	3.846 (97.7)	3.844 (97.6)
30	36	1.320 (33.5)	1.445 (36.7)	4.337 (110.2)	9.688 (246.1)
31	36	1.250 (31.8)	1.375 (34.9)	4.337 (110.2)	9.688 (246.1)
32	36	1.185 (30.1)	1.310 (33.3)	4.275 (108.6)	8.688 (220.7)
33	36	1.105 (28.1)	1.230 (31.2)	4.275 (108.6)	8.188 (208.0)
34	36	1.055 (26.8)	1.180 (30.0)	4.275 (108.6)	8.188 (208.0)
35	36	.984 (25.0)	1.109 (28.2)	4.212 (107.0)	7.688 (195.3)
36	36	.857 (21.8)	.970 (24.6)	4.154 (105.5)	7.188 (182.6)
37	40	1.815 (46.1)	1.940 (49.3)	5.673 (144.1)	13.188 (335.0)
38	40	1.700 (43.2)	1.825 (46.4)	5.673 (144.1)	13.188 (335.0)
39	40	1.605 (40.8)	1.730 (43.9)	5.673 (144.1)	13.188 (335.0)
40	40	1.531 (38.9)	1.656 (42.1)	5.373 (136.5)	12.688 (322.3)
41	44	1.862 (47.3)	2.000 (50.8)	5.673 (144.1)	14.188 (360.4)
42	44	1.775 (45.1)	1.900 (48.3)	4.594 (116.7)	12.688 (322.3)

Dimensions in inches (millimeters) and are subject to change without notice.

AS85049/6 and MS3189A 45° EMI/RFI Environmental Backshell



AS85049

B

CONNECTOR DESIGNATOR:	
A	AS50151 Series 34001
	MIL-DTL-26482 Series II
	AS81703 Series III
	MIL-DTL-83723 Series I & III
	40M39569, DEF 5326-3, EN 2997
	EN 3646, ESC 10, ESC 11, LN 29504
	NFC93422 Series HE302 PAN 6432-1, PAN 6432-2, PATT 602

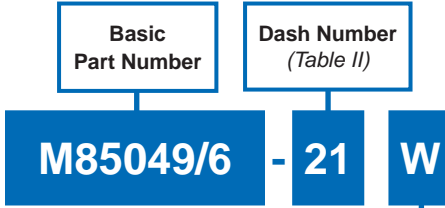

Finish / Material

B = Black Cadmium / Stainless Steel
N = Electroless Nickel / Aluminum
S = Passivated / Stainless Steel
W = 1,000 Hr. Cadmium Olive Drab
over Electroless Nickel / Aluminum
X = Aluminum, Nickel Fluorocarbon Polymer
Z = Aluminum, Zinc-Nickel, Black
XS = Stainless Steel, Nickel Fluorocarbon Polymer
ZS = Stainless Steel, Zinc-Nickel, Black

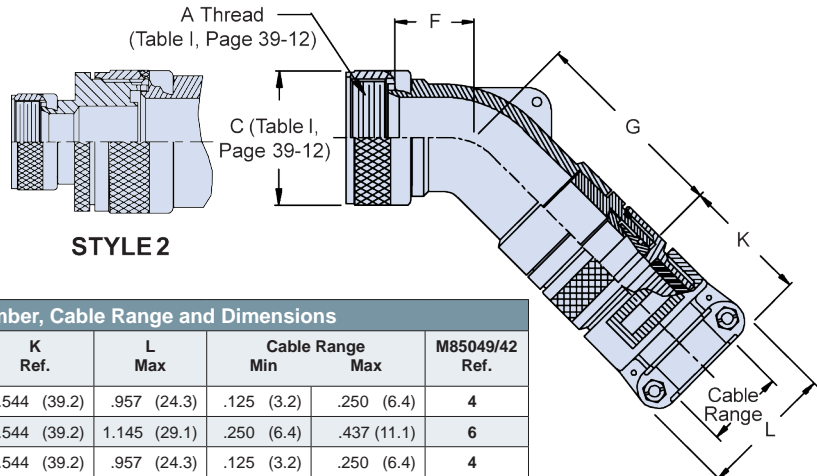
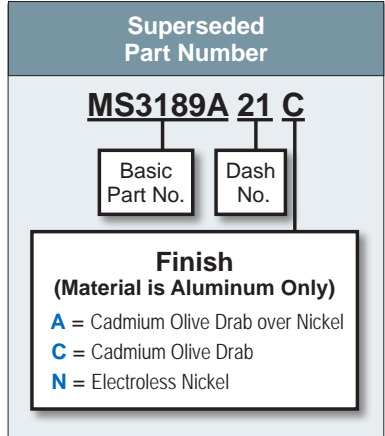

TABLE I: Dash Number, Cable Range and Dimensions									
Dash No.	Shell Size	F Max	G Max	K Ref.	L Max	Cable Range		M85049/42 Ref.	
						Min	Max		
1	3	.686 (17.4)	2.034 (51.7)	1.544 (39.2)	.957 (24.3)	.125 (3.2)	.250 (6.4)	4	
2	3	1.500 (38.1)	1.306 (33.2)	1.544 (39.2)	1.145 (29.1)	.250 (6.4)	.437 (11.1)	6	
3	8	.625 (15.9)	1.974 (50.1)	1.544 (39.2)	.957 (24.3)	.125 (3.2)	.250 (6.4)	4	
4	10	.686 (17.4)	1.369 (34.8)	1.544 (39.2)	.957 (24.3)	.125 (3.2)	.312 (7.9)	4	
5	10	.686 (17.4)	2.034 (51.7)	1.544 (39.2)	1.145 (29.1)	.250 (6.4)	.375 (9.5)	6	
6	12	.750 (19.1)	2.034 (51.7)	1.544 (39.2)	.957 (24.3)	.125 (3.2)	.312 (7.9)	4	
7	12	.750 (19.1)	2.034 (51.7)	1.544 (39.2)	1.145 (29.1)	.250 (6.4)	.437 (11.1)	6	
8	12	.750 (19.1)	2.124 (53.9)	1.844 (46.8)	1.332 (33.8)	.350 (8.9)	.500 (12.7)	10	
9	14	.813 (20.7)	1.779 (45.2)	1.544 (39.2)	1.145 (29.1)	.250 (6.4)	.437 (11.1)	6	
10	14	.813 (20.7)	2.234 (56.7)	1.844 (46.8)	1.332 (33.8)	.350 (8.9)	.575 (14.6)	10	
11	16	.906 (23.0)	1.874 (47.6)	1.544 (39.2)	1.145 (29.1)	.250 (6.4)	.437 (11.1)	6	
12	16	.906 (23.0)	2.424 (61.6)	1.916 (48.7)	1.551 (39.4)	.500 (12.7)	.700 (17.8)	12	
13	18	1.093 (27.8)	2.062 (52.4)	1.844 (46.8)	1.332 (33.8)	.350 (8.9)	.625 (15.9)	10	
14	18	1.093 (27.8)	2.424 (61.6)	2.000 (50.8)	1.770 (45.0)	.625 (15.9)	.779 (19.8)	16	
15	20	1.093 (27.8)	2.062 (52.4)	1.844 (46.8)	1.332 (33.8)	.350 (8.9)	.625 (15.9)	10	
16	20	1.093 (27.8)	2.574 (65.4)	2.000 (50.8)	1.770 (45.0)	.625 (15.9)	.904 (23.0)	16	
17	22	1.188 (30.2)	2.217 (56.3)	1.916 (48.7)	1.551 (39.4)	.500 (12.7)	.750 (19.1)	12	
18	22	1.188 (30.2)	2.574 (65.4)	2.230 (56.6)	2.113 (53.7)	.875 (22.2)	1.029 (26.1)	20	
19	24	1.188 (30.2)	2.217 (56.3)	1.916 (48.7)	1.551 (39.4)	.500 (12.7)	.750 (19.1)	12	
20	24	1.188 (30.2)	2.624 (66.6)	2.230 (56.6)	2.113 (53.7)	.875 (22.2)	1.144 (29.1)	20	
21	28	1.313 (33.4)	2.562 (65.1)	2.000 (50.8)	1.770 (45.0)	.625 (15.9)	.937 (23.8)	16	

Continued on Page B-20

- APPLICATION NOTES**

 - For complete dimensions see the applicable Military Specification.
 - When maximum cable entry is exceeded, Style 2 will be supplied.
 - Metric dimensions (mm) are in parentheses.
 - Cable Range is defined as the accommodation range for the wire bundle or cable. Dimensions shown are not intended for inspection criteria.

Dimensions in inches (millimeters) and are subject to change without notice.



AS85049/6 and MS3189A 45° EMI/RFI Environmental Backshell

TABLE I: Continued from Page B-19

Dash No.	Shell Size	F Max	G Max	K Ref.	L Max	Cable Range		M85049/42 Ref.
						Min	Max	
22	28	1.312 (33.3)	2.280 (57.9)	2.024 (51.4)	2.363 (60.0)	1.000 (25.4)	1.375 (34.9)	24
23	32	1.375 (34.9)	2.724 (69.2)	2.000 (50.8)	1.770 (45.0)	.625 (15.9)	.937 (23.8)	16
24	32	1.375 (34.9)	2.724 (69.2)	2.230 (56.6)	2.113 (53.7)	.875 (22.2)	1.250 (31.8)	20
25	32	1.375 (34.9)	2.374 (60.3)	2.550 (64.8)	2.770 (70.4)	1.250 (31.8)	1.625 (41.3)	28
26	36	1.406 (35.7)	2.814 (71.5)	2.000 (50.8)	1.770 (45.0)	.625 (15.9)	.937 (23.8)	16
27	36	1.406 (35.7)	2.814 (71.5)	2.024 (51.4)	2.363 (60.0)	1.000 (25.4)	1.375 (34.9)	24
28	36	1.406 (35.7)	2.468 (62.7)	2.600 (66.0)	3.020 (76.7)	1.437 (36.5)	1.840 (46.7)	32
29	40	2.156 (54.8)	2.634 (66.9)	2.000 (50.8)	1.770 (45.0)	.625 (15.9)	.937 (23.8)	16
30	40	2.156 (54.8)	2.634 (66.9)	2.024 (51.4)	2.363 (60.0)	1.000 (25.4)	1.375 (34.9)	24
31	40	2.156 (54.8)	2.468 (62.7)	2.600 (66.0)	3.020 (76.7)	1.437 (36.5)	1.875 (47.6)	32
32	44	2.156 (54.8)	2.814 (71.5)	2.000 (50.8)	1.770 (45.0)	.625 (15.9)	.937 (23.8)	16
33	44	2.156 (54.8)	2.468 (62.7)	2.024 (51.4)	2.363 (60.0)	1.000 (25.4)	1.375 (34.9)	24
34	44	2.156 (54.8)	2.468 (62.7)	2.600 (66.0)	3.020 (76.7)	1.437 (36.5)	1.875 (47.6)	32
35	48	2.156 (54.8)	2.814 (71.5)	2.000 (50.8)	1.770 (45.0)	.625 (15.9)	.937 (23.8)	16
36	48	2.156 (54.8)	2.814 (71.5)	2.024 (51.4)	2.363 (60.0)	1.000 (25.4)	1.375 (34.9)	24
37	48	2.156 (54.8)	2.468 (62.7)	2.600 (66.0)	3.020 (76.7)	1.437 (36.5)	1.875 (47.6)	32
38	61	1.188 (30.2)	2.574 (65.4)	1.916 (48.7)	1.551 (39.4)	.500 (12.7)	.750 (19.1)	12
39	61	1.188 (30.2)	2.217 (56.3)	2.230 (56.6)	2.113 (53.7)	.875 (22.2)	1.184 (30.1)	20
40	16	.906 (23.0)	2.234 (56.7)	1.844 (46.8)	1.332 (33.8)	.350 (8.9)	.625 (15.9)	10
41	18	1.093 (27.8)	2.424 (61.6)	1.544 (39.2)	.957 (24.3)	.125 (3.2)	.312 (7.9)	4
42	18	1.093 (27.8)	2.424 (61.6)	1.544 (39.2)	1.145 (29.1)	.250 (6.4)	.437 (11.1)	6
43	20	1.093 (27.8)	2.424 (61.6)	1.544 (39.2)	1.145 (29.1)	.250 (6.4)	.437 (11.1)	6
44	22	1.188 (30.2)	2.574 (65.4)	1.544 (39.2)	.957 (24.3)	.125 (3.2)	.312 (7.9)	4
45	22	1.188 (30.2)	2.574 (65.4)	1.544 (39.2)	1.145 (29.1)	.250 (6.4)	.437 (11.1)	6
46	24	1.188 (30.2)	2.574 (65.4)	1.844 (46.8)	1.332 (33.8)	.350 (8.9)	.625 (15.9)	10
47	36	1.406 (35.7)	2.814 (71.5)	1.916 (48.7)	1.551 (39.4)	.500 (12.7)	.750 (19.1)	12
48	40	2.156 (54.8)	2.814 (71.5)	1.916 (48.7)	1.551 (39.4)	.500 (12.7)	.750 (19.1)	12
49*	10	1.500 (38.1)	2.034 (51.7)	1.544 (39.2)	1.145 (29.1)	.250 (6.4)	.437 (11.1)	6
50*	14	1.842 (46.8)	2.424 (61.6)	1.916 (48.7)	1.551 (39.4)	.500 (12.7)	.750 (19.1)	12
51*	16	1.937 (49.2)	2.574 (65.4)	2.000 (50.8)	1.770 (45.0)	.625 (15.9)	.937 (23.8)	16
52	18	1.093 (27.8)	2.424 (61.6)	1.916 (48.7)	1.551 (39.4)	.500 (12.7)	.750 (19.1)	12
53	61	1.188 (30.2)	2.574 (65.4)	2.000 (50.8)	1.770 (45.0)	.625 (15.9)	.937 (23.8)	16
54	20	1.093 (27.8)	2.424 (61.6)	1.916 (48.7)	1.551 (39.4)	.500 (12.7)	.750 (19.1)	12
55*	20	2.061 (52.3)	2.624 (66.6)	2.230 (56.6)	2.113 (53.7)	.875 (22.2)	1.250 (31.8)	20
56	22	1.188 (30.2)	2.574 (65.4)	1.844 (46.8)	1.332 (33.8)	.350 (8.9)	.625 (15.9)	10
57	22	1.188 (30.2)	2.574 (65.4)	2.000 (50.8)	1.770 (45.0)	.625 (15.9)	.937 (23.8)	16
58*	22	2.061 (52.3)	2.624 (66.6)	2.230 (56.6)	2.113 (53.7)	.875 (22.2)	1.250 (31.8)	20
59	24	1.188 (30.2)	2.574 (65.4)	2.000 (50.8)	1.770 (45.0)	.625 (15.9)	.937 (23.8)	16
60	28	1.313 (33.4)	2.624 (66.6)	1.916 (48.7)	1.551 (39.4)	.500 (12.7)	.750 (19.1)	12
61	28	1.313 (33.4)	2.624 (66.6)	2.230 (56.6)	2.113 (53.7)	.875 (22.2)	1.250 (31.8)	20
62	32	1.375 (34.9)	2.724 (69.2)	2.024 (51.4)	2.363 (60.0)	1.000 (25.4)	1.375 (34.9)	24
63	36	1.406 (35.7)	2.814 (71.5)	2.230 (56.6)	2.113 (53.7)	.875 (22.2)	1.250 (31.8)	20
64	36	1.406 (35.7)	2.814 (71.5)	2.550 (64.8)	2.770 (70.4)	1.250 (31.8)	1.625 (41.3)	28
65	40	2.156 (54.8)	2.814 (71.5)	2.230 (56.6)	2.113 (53.7)	.875 (22.2)	1.250 (31.8)	20
66	40	2.156 (54.8)	2.814 (71.5)	2.550 (64.8)	2.770 (70.4)	1.250 (31.8)	1.625 (41.3)	28
67	44	2.156 (54.8)	2.814 (71.5)	2.230 (56.6)	2.113 (53.7)	.875 (22.2)	1.250 (31.8)	20
68	44	2.156 (54.8)	2.814 (71.5)	2.550 (64.8)	2.770 (70.4)	1.250 (31.8)	1.625 (41.3)	28
69	48	2.156 (54.8)	2.814 (71.5)	2.230 (56.6)	2.113 (53.7)	.875 (22.2)	1.250 (31.8)	20
70	48	2.156 (54.8)	2.814 (71.5)	2.550 (64.8)	2.770 (70.4)	1.250 (31.8)	1.625 (41.3)	28
71*	12	1.654 (42.0)	2.234 (56.4)	1.844 (46.8)	1.332 (33.8)	.350 (8.9)	.625 (15.9)	10
72*	18	1.937 (49.2)	2.574 (65.4)	2.000 (50.8)	1.770 (45.0)	.625 (15.9)	.937 (23.8)	16
73*	24	2.061 (52.3)	2.624 (66.6)	2.230 (56.6)	2.116 (53.7)	.875 (22.2)	1.250 (31.8)	20
74	14	.813 (20.7)	2.124 (53.9)	1.544 (39.2)	.957 (24.3)	.125 (3.2)	.312 (7.9)	04
75	16	.906 (23.0)	2.234 (56.4)	1.544 (39.2)	.957 (24.3)	.125 (3.2)	.312 (7.9)	04

* Denotes Style 2

Dimensions in inches (millimeters) and are subject to change without notice.

AS85049/7 and MS3189B 45° Environmental Backshell



AS85049

B

CONNECTOR DESIGNATOR:

A	AS50151 Series AS34001
	MIL-DTL-26482 Series II
	AS81703 Series III
	MIL-DTL-83723 Series I & III
	40M39569, DEF 5326-3, EN 2997
	EN 3646, ESC 10, ESC 11, LN 29504
	NFC93422 Series HE302 PAN 6432-1, PAN 6432-2, PATT 602

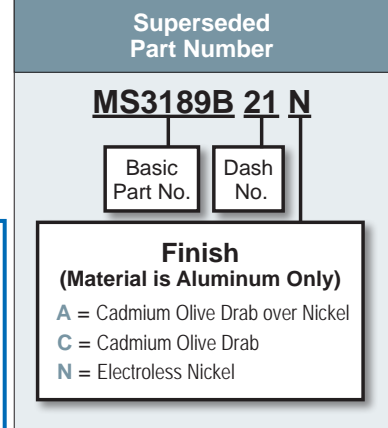
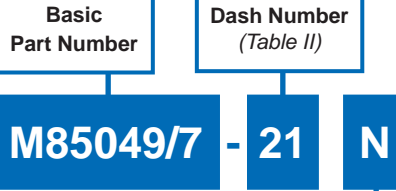

APPLICATION NOTES

- For complete dimensions see the applicable Military Specification.
- Metric dimensions (mm) are in parentheses.
- When maximum cable entry is exceeded, Style 2 will be supplied.
- Cable Range is defined as the accommodation range for the wire bundle or cable. Dimensions shown are not intended for inspection criteria.
- Approximate chain lengths: Dash No. 01-12 = 5.0 (127.0); Dash No. 13-29 = 6.0 (152.4).

Finish / Material

B = Black Cadmium / Stainless Steel
N = Electroless Nickel / Aluminum
S = Passivated / Stainless Steel
W = 1,000 Hr. Cadmium Olive Drab over Electroless Nickel / Aluminum
X = Nickel Fluorocarbon Polymer / Aluminum
Y = Pure Dense Electrodeposited Aluminum / Aluminum
Z = Zinc Nickel, Black / Aluminum
XS = Nickel Fluorocarbon Polymer / Stainless Steel
YS = Pure Dense Electrodeposited Aluminum / Stainless Steel
ZS = Zinc Nickel, Black / Stainless Steel

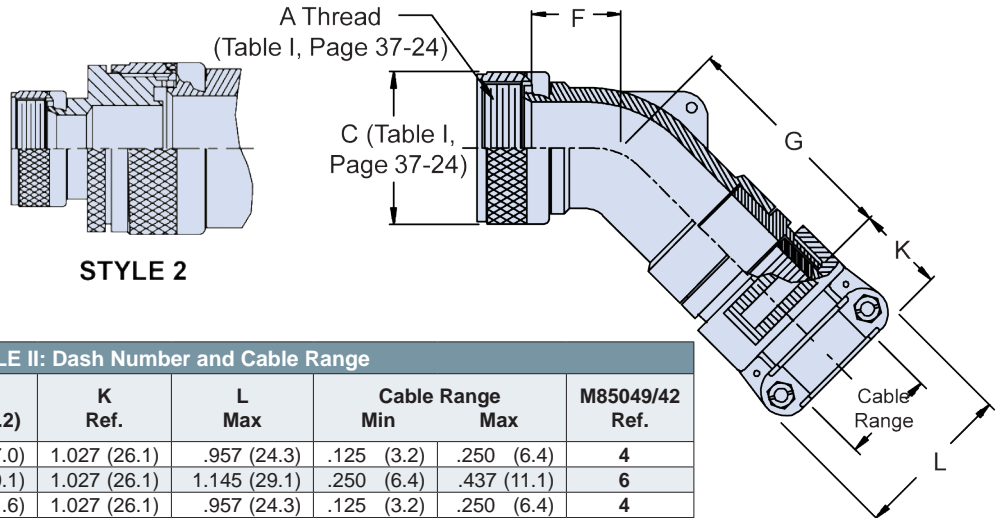

STYLE 2

TABLE II: Dash Number and Cable Range

Dash No.	Shell Size	F Max	G ± .125 (3.2)	K Ref.	L Max	Cable Range Min	Cable Range Max	M85049/42 Ref.
1	03	.688 (17.5)	1.852 (47.0)	1.027 (26.1)	.957 (24.3)	.125 (3.2)	.250 (6.4)	4
2	03	1.500 (38.1)	1.972 (50.1)	1.027 (26.1)	1.145 (29.1)	.250 (6.4)	.437 (11.1)	6
3	08	.625 (15.9)	1.244 (31.6)	1.027 (26.1)	.957 (24.3)	.125 (3.2)	.250 (6.4)	4
4	10	.688 (17.5)	1.912 (48.6)	1.027 (26.1)	.957 (24.3)	.125 (3.2)	.312 (7.9)	4
5	10	.688 (17.5)	1.307 (33.2)	1.027 (26.1)	1.145 (29.1)	.250 (6.4)	.375 (9.5)	6
6	12	.750 (19.1)	1.972 (50.1)	1.027 (26.1)	.957 (24.3)	.125 (3.2)	.312 (7.9)	4
7	12	.750 (19.1)	1.972 (50.1)	1.027 (26.1)	1.145 (29.1)	.250 (6.4)	.437 (11.1)	6
8	12	.750 (19.1)	1.972 (50.1)	1.027 (26.1)	1.332 (33.8)	.350 (8.9)	.500 (12.7)	10
9	14	.812 (20.6)	2.062 (52.4)	1.027 (26.1)	1.145 (29.1)	.250 (6.4)	.437 (11.1)	6
10	14	.812 (20.6)	1.717 (43.6)	1.027 (26.1)	1.332 (33.8)	.350 (8.9)	.575 (14.6)	10
11	16	.906 (23.0)	2.172 (55.2)	1.027 (26.1)	1.145 (29.1)	.250 (6.4)	.437 (11.1)	6
12	16	.906 (23.0)	1.812 (46.0)	1.059 (26.9)	1.551 (39.4)	.500 (12.7)	.700 (17.8)	12
13	18	1.093 (27.8)	2.362 (60.0)	1.027 (26.1)	1.332 (33.8)	.350 (8.9)	.625 (15.9)	10
14	18	1.093 (27.8)	2.000 (50.8)	1.156 (29.4)	1.770 (45.0)	.625 (15.9)	.779 (19.8)	16
15	20	1.093 (27.8)	2.362 (60.0)	1.027 (26.1)	1.332 (33.8)	.350 (8.9)	.625 (15.9)	10
16	20	1.093 (27.8)	2.000 (50.8)	1.156 (29.4)	1.770 (45.0)	.625 (15.9)	.904 (23.0)	16
17	22	1.188 (30.2)	2.512 (63.8)	1.059 (26.9)	1.551 (39.4)	.500 (12.7)	.750 (19.1)	12
18	22	1.188 (30.2)	2.155 (54.7)	1.375 (34.9)	2.113 (53.7)	.875 (22.2)	1.029 (26.1)	20
19	24	1.188 (30.2)	2.512 (63.8)	1.059 (26.9)	1.551 (39.4)	.500 (12.7)	.750 (19.1)	12
20	24	1.188 (30.2)	2.093 (53.2)	1.375 (34.9)	2.113 (53.7)	.875 (22.2)	1.144 (29.1)	20
21	28	1.312 (33.3)	2.500 (63.5)	1.156 (33.7)	1.770 (45.0)	.625 (15.9)	.937 (23.8)	16

Table Continued on Page B-22

Dimensions in inches (millimeters) and are subject to change without notice.



AS85049/7 and MS3189B 45° Environmental Backshell

TABLE II: Dash Number and Cable Range (Continued From Page B-21)

Dash No.	Shell Size	F Max	G ± .125 (3.2)	K Ref.	L Max	Cable Range		M85049/42 Ref.
						Min	Max	
22	28	1.312 (33.3)	2.218 (56.3)	1.500 (38.1)	2.363 (60.0)	1.000 (25.4)	1.375 (34.9)	24
23	32	1.375 (34.9)	2.662 (67.6)	1.156 (29.4)	1.770 (45.0)	.625 (15.9)	.937 (23.8)	16
24	32	1.375 (34.9)	2.662 (67.6)	1.375 (34.9)	2.113 (53.7)	.875 (22.2)	1.250 (31.8)	20
25	32	1.375 (34.9)	2.312 (58.7)	1.781 (45.2)	2.770 (70.4)	1.250 (31.8)	1.625 (41.3)	28
26	36	1.406 (35.7)	2.752 (69.9)	1.156 (29.4)	1.770 (45.0)	.625 (15.9)	.937 (23.8)	16
27	36	1.406 (35.7)	2.752 (69.9)	1.500 (38.1)	2.363 (60.0)	1.000 (25.4)	1.375 (34.9)	24
28	36	1.406 (35.7)	2.406 (61.1)	1.830 (46.5)	3.020 (76.7)	1.437 (36.5)	1.840 (46.7)	32
29	40	2.156 (54.8)	2.752 (69.9)	1.156 (29.4)	1.770 (45.0)	.625 (15.9)	.937 (23.8)	16
30	40	2.156 (54.8)	2.752 (69.9)	1.500 (38.1)	2.363 (60.0)	1.000 (25.4)	1.375 (34.9)	24
31	40	2.156 (54.8)	2.406 (61.1)	1.830 (46.5)	3.020 (76.7)	1.437 (36.5)	1.875 (47.6)	32
32	44	2.156 (54.8)	2.752 (69.9)	1.156 (29.4)	1.770 (45.0)	.625 (15.9)	.937 (23.8)	16
33	44	2.156 (54.8)	2.752 (69.9)	1.500 (38.1)	2.363 (60.0)	1.000 (25.4)	1.375 (34.9)	24
34	44	2.156 (54.8)	2.406 (61.1)	1.830 (46.5)	3.020 (76.7)	1.437 (36.5)	1.875 (47.6)	32
35	48	2.156 (54.8)	2.752 (69.9)	1.156 (29.4)	1.770 (45.0)	.625 (15.9)	.937 (23.8)	16
36	48	2.156 (54.8)	2.752 (69.9)	1.500 (38.1)	2.363 (60.0)	1.000 (25.4)	1.375 (34.9)	24
37	48	2.156 (54.8)	2.406 (61.1)	1.830 (46.5)	3.020 (76.7)	1.437 (36.5)	1.875 (47.6)	32
38	61	1.188 (30.2)	2.512 (63.8)	1.059 (26.9)	1.551 (39.4)	.500 (12.7)	.750 (19.1)	12
39	61	1.188 (30.2)	2.155 (54.7)	1.375 (34.9)	2.113 (53.7)	.875 (22.2)	1.184 (30.1)	20
40	16	.906 (23.0)	2.172 (55.2)	1.027 (26.1)	1.332 (33.8)	.350 (8.9)	.625 (15.9)	10
41	18	1.093 (27.8)	2.362 (60.0)	1.027 (26.1)	.957 (24.3)	.125 (3.2)	.312 (7.9)	4
42	18	1.093 (27.8)	2.362 (60.0)	1.027 (26.1)	1.145 (29.1)	.250 (6.4)	.437 (11.1)	6
43	20	1.093 (27.8)	2.362 (60.0)	1.027 (26.1)	1.145 (29.1)	.250 (6.4)	.437 (11.1)	6
44	22	1.188 (30.2)	2.512 (63.8)	1.027 (26.1)	.957 (24.3)	.125 (3.2)	.312 (7.9)	4
45	22	1.188 (30.2)	2.512 (63.8)	1.027 (26.1)	1.145 (29.1)	.250 (6.4)	.437 (11.1)	6
46	24	1.188 (30.2)	2.512 (63.8)	1.027 (26.1)	1.332 (33.8)	.350 (8.9)	.625 (15.9)	10
47	36	1.406 (35.7)	2.752 (69.9)	1.059 (26.9)	1.551 (39.4)	.500 (12.7)	.750 (19.1)	12
48	40	2.156 (54.8)	2.752 (69.9)	1.059 (26.9)	1.551 (39.4)	.500 (12.7)	.750 (19.1)	12
49*	10	1.500 (38.1)	1.972 (50.1)	1.027 (26.1)	1.145 (29.1)	.250 (6.4)	.437 (11.1)	6
50*	14	1.842 (46.8)	2.362 (60.0)	1.059 (26.9)	1.551 (39.4)	.500 (12.7)	.750 (19.1)	12
51*	16	1.938 (49.2)	2.512 (63.8)	1.156 (29.4)	1.770 (45.0)	.625 (15.9)	.937 (23.8)	16
52	18	1.093 (27.8)	2.362 (60.0)	1.059 (26.9)	1.551 (39.4)	.500 (12.7)	.750 (19.1)	12
53	61	1.188 (30.2)	2.512 (63.8)	1.156 (29.4)	1.770 (45.0)	.625 (15.9)	.937 (23.8)	16
54	20	1.093 (27.8)	2.362 (60.0)	1.059 (26.9)	1.551 (39.4)	.500 (12.7)	.750 (19.1)	12
55*	20	2.061 (52.3)	2.562 (65.1)	1.375 (34.9)	2.113 (53.7)	.875 (22.2)	1.250 (31.8)	20
56	22	1.188 (30.2)	2.512 (63.8)	1.027 (26.1)	1.332 (33.8)	.350 (8.9)	.625 (15.9)	10
57	22	1.188 (30.2)	2.512 (63.8)	1.156 (29.4)	1.770 (45.0)	.625 (15.9)	.937 (23.8)	16
58*	22	2.061 (52.3)	2.562 (65.1)	1.375 (34.9)	2.113 (53.7)	.875 (22.2)	1.250 (31.8)	20
59	24	1.188 (30.2)	2.512 (63.8)	1.156 (29.4)	1.770 (45.0)	.625 (15.9)	.937 (23.8)	16
60	28	1.312 (33.3)	2.562 (65.1)	1.059 (26.9)	1.551 (39.4)	.500 (12.7)	.750 (19.1)	12
61	28	1.312 (33.3)	2.562 (65.1)	1.375 (34.9)	2.113 (53.7)	.875 (22.2)	1.250 (31.8)	20
62	32	1.375 (34.9)	2.662 (67.6)	1.500 (38.1)	2.363 (60.0)	1.000 (25.4)	1.375 (34.9)	24
63	36	1.406 (35.7)	2.752 (69.9)	1.375 (34.9)	2.113 (53.7)	.875 (22.2)	1.250 (31.8)	20
64	36	1.406 (35.7)	2.752 (69.9)	1.781 (45.2)	2.770 (70.4)	1.250 (31.8)	1.625 (41.3)	28
65	40	2.156 (54.8)	2.752 (69.9)	1.375 (34.9)	2.113 (53.7)	.875 (22.2)	1.250 (31.8)	20
66	40	2.156 (54.8)	2.752 (69.9)	1.781 (45.2)	2.770 (70.4)	1.250 (31.8)	1.625 (41.3)	28
67	44	2.156 (54.8)	2.752 (69.9)	1.375 (34.9)	2.113 (53.7)	.875 (22.2)	1.250 (31.8)	20
68	44	2.156 (54.8)	2.752 (69.9)	1.781 (45.2)	2.770 (70.4)	1.250 (31.8)	1.625 (41.3)	28
69	48	2.156 (54.8)	2.752 (69.9)	1.375 (34.9)	2.113 (53.7)	.875 (22.2)	1.250 (31.8)	20
70	48	2.156 (54.8)	2.752 (69.9)	1.781 (45.2)	2.770 (70.4)	1.250 (31.8)	1.625 (41.3)	28
71*	12	1.654 (42.0)	2.173 (55.2)	1.027 (26.1)	1.332 (33.8)	.350 (8.9)	.625 (15.9)	10
72*	18	1.938 (49.2)	2.512 (63.8)	1.156 (29.4)	1.770 (45.0)	.625 (15.9)	.937 (23.8)	16
73*	24	2.061 (52.3)	2.562 (65.1)	1.375 (34.9)	2.113 (53.7)	.875 (22.2)	1.250 (31.8)	20
74	14	.812 (20.6)	2.062 (52.4)	1.027 (26.1)	.957 (24.3)	.125 (3.2)	.312 (7.9)	4
75	16	.906 (23.0)	2.172 (55.2)	1.027 (26.1)	.957 (24.3)	.125 (3.2)	.312 (7.9)	4

Dimensions in inches (millimeters) and are subject to change without notice.

AS85049/8 and MS3188A 90° EMI/RFI Environmental Backshell



AS85049

B

CONNECTOR DESIGNATOR:

A
AS50151 Series AS34001
MIL-DTL-26482 Series II
AS81703 Series III
MIL-DTL-83723 Series I & III
40M39569, DEF 5326-3, EN 2997
EN 3646, ESC 10, ESC 11,
LN 29504
NFC93422 Series HE302
PAN 6432-1, PAN 6432-2,
PATT 602

Basic
Part Number

Dash Number
(Table I)

M85049/8

- 21

W

Superseded
Part Number

MS3188A 21 C

Basic
Part No.

Dash
No.

**Finish
(Material is Aluminum Only)**

A = Cadmium Olive Drab over Nickel
C = Cadmium Olive Drab
N = Electroless Nickel

Finish / Material

B = Black Cadmium / Stainless Steel
N = Electroless Nickel / Aluminum
S = Passivated / Stainless Steel
W = 1,000 Hr. Cadmium Olive Drab
over Electroless Nickel / Aluminum
X = Aluminum, Nickel Fluorocarbon Polymer
Z = Aluminum, Zinc-Nickel, Black
XS = Stainless Steel, Nickel Fluorocarbon Polymer
ZS = Stainless Steel, Zinc-Nickel, Black

APPLICATION NOTES

- For complete dimensions see the applicable Military Specification.
- When maximum cable entry is exceeded, Style 2 will be supplied.
- Metric dimensions (mm) are in parentheses.
- Cable Range is defined as the accommodation range for the wire bundle or cable. Dimensions shown are not intended for inspection criteria.

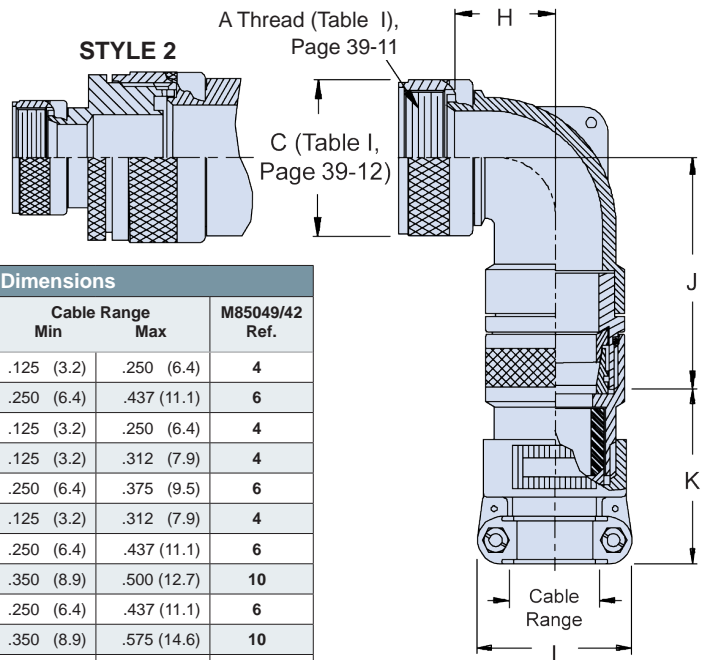

TABLE I: Dash Number, Cable Range and Dimensions

Dash No.	Shell Size	H Max	J Max	K Ref.	L Max	Cable Range Min	Cable Range Max	M85049/42 Ref.
1	3	.761 (19.3)	1.924 (48.9)	1.544 (39.2)	.957 (24.3)	.125 (3.2)	.250 (6.4)	4
2	3	1.511 (38.4)	1.444 (36.7)	1.544 (39.2)	1.145 (29.1)	.250 (6.4)	.437 (11.1)	6
3	8	.666 (16.9)	1.324 (33.6)	1.544 (39.2)	.957 (24.3)	.125 (3.2)	.250 (6.4)	4
4	10	.761 (19.3)	2.044 (51.9)	1.544 (39.2)	.957 (24.3)	.125 (3.2)	.312 (7.9)	4
5	10	.761 (19.3)	1.444 (36.7)	1.544 (39.2)	1.145 (29.1)	.250 (6.4)	.375 (9.5)	6
6	12	.766 (19.5)	2.064 (52.4)	1.544 (39.2)	.957 (24.3)	.125 (3.2)	.312 (7.9)	4
7	12	.766 (19.5)	2.064 (52.4)	1.544 (39.2)	1.145 (29.1)	.250 (6.4)	.437 (11.1)	6
8	12	.766 (19.5)	1.459 (37.1)	1.844 (46.8)	1.332 (33.8)	.350 (8.9)	.500 (12.7)	10
9	14	.866 (22.0)	2.134 (54.2)	1.544 (39.2)	1.145 (29.1)	.250 (6.4)	.437 (11.1)	6
10	14	.866 (22.0)	1.779 (45.2)	1.844 (46.8)	1.332 (33.8)	.350 (8.9)	.575 (14.6)	10
11	16	1.051 (26.7)	2.224 (56.5)	1.544 (39.2)	1.145 (29.1)	.250 (6.4)	.437 (11.1)	6
12	16	1.051 (26.7)	1.869 (47.5)	1.916 (48.7)	1.551 (39.4)	.500 (12.7)	.700 (17.8)	12
13	18	1.141 (29.0)	2.394 (60.8)	1.844 (46.8)	1.332 (33.8)	.350 (8.9)	.625 (15.9)	10
14	18	1.141 (29.0)	2.044 (51.9)	2.000 (50.8)	1.770 (45.0)	.625 (15.9)	.779 (19.8)	16
15	20	1.141 (29.0)	2.394 (60.8)	1.844 (46.8)	1.332 (33.8)	.350 (8.9)	.625 (15.9)	10
16	20	1.141 (29.0)	2.044 (51.9)	2.000 (50.8)	1.770 (45.0)	.625 (15.9)	.904 (23.0)	16
17	22	1.291 (32.8)	2.504 (63.6)	1.916 (48.7)	1.551 (39.4)	.500 (12.7)	.750 (19.1)	12
18	22	1.291 (32.8)	2.149 (54.6)	2.230 (56.6)	2.113 (53.7)	.875 (22.2)	1.029 (26.1)	20
19	24	1.291 (32.8)	2.504 (63.6)	1.916 (48.7)	1.551 (39.4)	.500 (12.7)	.750 (19.1)	12
20	24	1.291 (32.8)	2.149 (54.6)	2.230 (56.6)	2.113 (53.7)	.875 (22.2)	1.144 (29.1)	20
21	28	1.391 (35.3)	2.674 (67.9)	2.000 (50.8)	1.770 (45.0)	.625 (15.9)	.937 (23.8)	16

Continued on Page B-23

Dimensions in inches (millimeters) and are subject to change without notice.

© 2013 Glenair, Inc.

U.S. CAGE Code 06324

Printed in U.S.A.



AS85049/8 and MS3188A 90° EMI/RFI Environmental Backshell

B

TABLE I: Continued from Page B-23

Dash No.	Shell Size	H Max	J Max	K Ref.	L Max	Cable Range		M85049/42 Ref.
						Min	Max	
22	28	1.391 (35.3)	2.319 (58.9)	2.024 (51.4)	2.363 (60.0)	1.000 (25.4)	1.375 (34.9)	24
23	32	1.741 (44.2)	2.924 (74.3)	2.000 (50.8)	1.770 (45.0)	.625 (15.9)	.937 (23.8)	16
24	32	1.741 (44.2)	2.924 (74.3)	2.230 (56.6)	2.113 (53.7)	.875 (22.2)	1.250 (31.8)	20
25	32	1.741 (44.2)	2.569 (65.3)	2.550 (64.8)	2.770 (70.4)	1.250 (31.8)	1.625 (41.3)	28
26	36	1.941 (49.3)	2.894 (73.5)	2.000 (50.8)	1.770 (45.0)	.625 (15.9)	.937 (23.8)	16
27	36	1.941 (49.3)	2.894 (73.5)	2.024 (51.4)	2.363 (60.0)	1.000 (25.4)	1.375 (34.9)	24
28	36	1.941 (49.3)	2.539 (64.5)	2.600 (66.0)	3.020 (76.7)	1.437 (36.5)	1.840 (46.7)	32
29	40	2.691 (68.4)	2.894 (73.5)	2.000 (50.8)	1.770 (45.0)	.625 (15.9)	.937 (23.8)	16
30	40	2.691 (68.4)	2.894 (73.5)	2.024 (51.4)	2.363 (60.0)	1.000 (25.4)	1.375 (34.9)	24
31	40	2.691 (68.4)	2.539 (64.5)	2.600 (66.0)	3.020 (76.7)	1.437 (36.5)	1.875 (47.6)	32
32	44	2.691 (68.4)	2.894 (73.5)	2.000 (50.8)	1.770 (45.0)	.625 (15.9)	.937 (23.8)	16
33	44	2.691 (68.4)	2.894 (73.5)	2.024 (51.4)	2.363 (60.0)	1.000 (25.4)	1.375 (34.9)	24
34	44	2.691 (68.4)	2.539 (64.5)	2.600 (66.0)	3.020 (76.7)	1.437 (36.5)	1.875 (47.6)	32
35	48	2.691 (68.4)	2.894 (73.5)	2.000 (50.8)	1.770 (45.0)	.625 (15.9)	.937 (23.8)	16
36	48	2.691 (68.4)	2.894 (73.5)	2.024 (51.4)	2.363 (60.0)	1.000 (25.4)	1.375 (34.9)	24
37	48	2.691 (68.4)	2.539 (64.5)	2.600 (66.0)	3.020 (76.7)	1.437 (36.5)	1.875 (47.6)	32
38	61	1.291 (32.8)	2.504 (63.6)	1.916 (48.7)	1.551 (39.4)	.500 (12.7)	.750 (19.1)	12
39	61	1.291 (32.8)	2.149 (54.6)	2.230 (56.6)	2.113 (53.7)	.875 (22.2)	1.184 (30.1)	20
40	16	1.051 (26.7)	2.224 (56.5)	1.844 (46.8)	1.332 (33.8)	.350 (8.9)	.625 (15.9)	10
41	18	1.141 (29.0)	2.394 (60.8)	1.544 (39.2)	.957 (24.3)	.125 (3.2)	.312 (7.9)	4
42	18	1.141 (29.0)	2.394 (60.8)	1.544 (39.2)	1.145 (29.1)	.250 (6.4)	.437 (11.1)	6
43	20	1.141 (29.0)	2.394 (60.8)	1.544 (39.2)	1.145 (29.1)	.250 (6.4)	.437 (11.1)	6
44	22	1.291 (32.8)	2.504 (63.6)	1.544 (39.2)	.957 (24.3)	.125 (3.2)	.312 (7.9)	4
45	22	1.291 (32.8)	2.504 (63.6)	1.544 (39.2)	1.145 (29.1)	.250 (6.4)	.437 (11.1)	6
46	24	1.291 (32.8)	2.504 (63.6)	1.844 (46.8)	1.332 (33.8)	.350 (8.9)	.625 (15.9)	10
47	36	1.941 (49.3)	2.894 (73.5)	1.916 (48.7)	1.551 (39.4)	.500 (12.7)	.750 (19.1)	12
48	40	1.941 (49.3)	2.894 (73.5)	1.916 (48.7)	1.551 (39.4)	.500 (12.7)	.750 (19.1)	12
49*	10	1.516 (38.5)	2.064 (52.4)	1.544 (39.2)	1.145 (29.1)	.250 (6.4)	.437 (11.1)	6
50*	14	1.891 (48.0)	2.394 (60.8)	1.916 (48.7)	1.551 (39.4)	.500 (12.7)	.750 (19.1)	12
51*	16	2.041 (51.8)	2.504 (63.6)	2.000 (50.8)	1.770 (45.0)	.625 (15.9)	.937 (23.8)	16
52	18	1.141 (29.0)	2.394 (60.8)	1.916 (48.7)	1.551 (39.4)	.500 (12.7)	.750 (19.1)	12
53	61	1.291 (32.8)	2.149 (54.6)	2.000 (50.8)	1.770 (45.0)	.625 (15.9)	.937 (23.8)	16
54	20	1.141 (29.0)	2.394 (60.8)	1.916 (48.7)	1.551 (39.4)	.500 (12.7)	.750 (19.1)	12
55*	20	2.141 (54.4)	2.674 (67.9)	2.230 (56.6)	2.113 (53.7)	.875 (22.2)	1.250 (31.8)	20
56	22	1.291 (32.8)	2.504 (63.6)	1.844 (46.8)	1.332 (33.8)	.350 (8.9)	.625 (15.9)	10
57	22	1.291 (32.8)	2.504 (63.6)	2.000 (50.8)	1.770 (45.0)	.625 (15.9)	.937 (23.8)	16
58*	22	2.141 (54.4)	2.674 (67.9)	2.230 (56.6)	2.113 (53.7)	.875 (22.2)	1.250 (31.8)	20
59	24	1.291 (32.8)	2.504 (63.6)	2.000 (50.8)	1.770 (45.0)	.625 (15.9)	.937 (23.8)	16
60	28	1.391 (35.3)	2.674 (67.9)	1.916 (48.7)	1.551 (39.4)	.500 (12.7)	.750 (19.1)	12
61	28	1.391 (35.3)	2.674 (67.9)	2.230 (56.6)	2.113 (53.7)	.875 (22.2)	1.250 (31.8)	20
62	32	1.741 (44.2)	2.924 (74.3)	2.024 (51.4)	2.363 (60.0)	1.000 (25.4)	1.375 (34.9)	24
63	36	1.941 (49.3)	2.894 (73.5)	2.230 (56.6)	2.113 (53.7)	.875 (22.2)	1.250 (31.8)	20
64	36	1.941 (49.3)	2.894 (73.5)	2.550 (64.8)	2.770 (70.4)	1.250 (31.8)	1.625 (41.3)	28
65	40	2.691 (68.4)	2.894 (73.5)	2.230 (56.6)	2.113 (53.7)	.875 (22.2)	1.250 (31.8)	20
66	40	2.691 (68.4)	2.894 (73.5)	2.550 (64.8)	2.770 (70.4)	1.250 (31.8)	1.625 (41.3)	28
67	44	2.691 (68.4)	2.894 (73.5)	2.230 (56.6)	2.113 (53.7)	.875 (22.2)	1.250 (31.8)	20
68	44	2.691 (68.4)	2.894 (73.5)	2.550 (64.8)	2.770 (70.4)	1.250 (31.8)	1.625 (41.3)	28
69	48	2.691 (68.4)	2.894 (73.5)	2.230 (56.6)	2.113 (53.7)	.875 (22.2)	1.250 (31.8)	20
70	48	2.691 (68.4)	2.894 (73.5)	2.550 (64.8)	2.770 (70.4)	1.250 (31.8)	1.625 (41.3)	28
71*	12	1.811 (46.0)	2.224 (56.5)	1.844 (46.8)	1.332 (33.8)	.350 (8.9)	.625 (15.9)	10
72*	18	2.051 (52.1)	2.504 (63.6)	2.000 (50.8)	1.770 (45.0)	.625 (15.9)	.937 (23.8)	16
73*	24	2.151 (54.6)	2.674 (67.9)	2.230 (56.6)	2.116 (53.7)	.875 (22.2)	1.250 (31.8)	20
74	14	.866 (22.0)	2.134 (54.2)	1.544 (39.2)	.957 (24.3)	.125 (3.2)	.312 (7.9)	04
75	16	1.051 (26.7)	2.224 (56.5)	1.544 (39.2)	.957 (24.3)	.125 (3.2)	.312 (7.9)	04

* Denotes Style 2

Dimensions in inches (millimeters) and are subject to change without notice.

AS85049/9 and MS3188B 90° Environmental Backshell



AS85049

CONNECTOR DESIGNATOR:

A

AS50151 Series AS34001
MIL-DTL-26482 Series II
AS81703 Series III
MIL-DTL-83723 Series I & III
40M39569, DEF 5326-3, EN 2997
EN 3646, ESC 10, ESC 11, LN 29504
NFC93422 Series HE302
PAN 6432-1, PAN 6432-2, PATT 602

Basic
Part Number

Dash Number
(Table II)

M85049/9

- 21

N

Superseded
Part Number

MS3188B 21 N

Basic
Part No.

Dash
No.

Finish (Material is Aluminum Only)

A = Cadmium Olive Drab over Nickel
C = Cadmium Olive Drab
N = Electroless Nickel

B

Finish / Material

B = Black Cadmium / Stainless Steel
N = Electroless Nickel / Aluminum
S = Passivated / Stainless Steel
W = 1,000 Hr. Cadmium Olive Drab
over Electroless Nickel / Aluminum
X = Nickel Fluorocarbon Polymer
Y = Pure Dense Electrodeposited Aluminum
Z = Zinc Nickel
XS = Nickel Fluorocarbon Polymer / Stainless Steel
YS = Pure Dense Electrodeposited Aluminum / Stainless Steel
ZS = Zinc Nickel, Black / Stainless Steel

APPLICATION NOTES

- For complete dimensions see the applicable Military Specification.
- Metric dimensions (mm) are in parentheses.
- When maximum cable entry is exceeded, Style 2 will be supplied.
- Cable Range is defined as the accommodation range for the wire bundle or cable. Dimensions shown are not intended for inspection criteria.
- Approximate chain lengths: Dash No. 01-12 = 5.0 (127.0); Dash No. 13-29 = 6.0 (152.4).

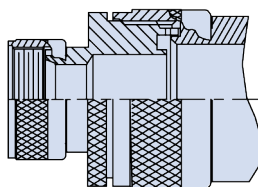

STYLE 2

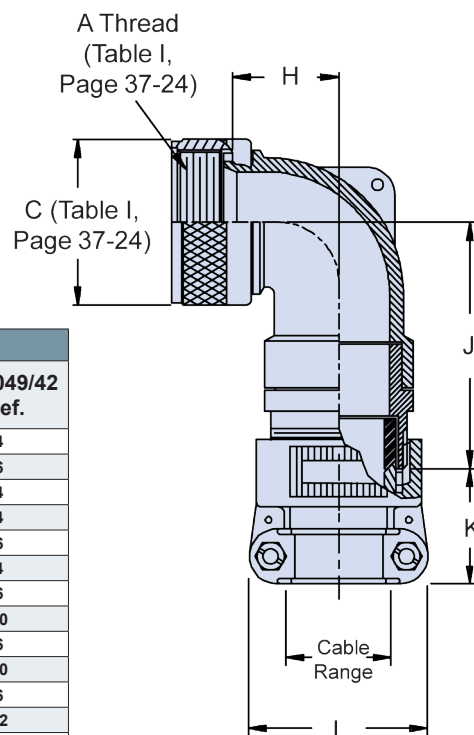

TABLE II: Dash Number and Cable Range (Continued on Page B-26)

Dash No.	Shell Size	H Max	J Max	K Ref.	L Max	Cable Range Min	Cable Range Max	M85049/42 Ref.
1	03	.761 (19.3)	1.862 (47.3)	1.027 (26.1)	.957 (24.3)	.125 (3.2)	.250 (6.4)	4
2	03	1.511 (38.4)	1.382 (35.1)	1.027 (26.1)	1.145 (29.1)	.250 (6.4)	.437 (11.1)	6
3	08	.666 (16.9)	1.262 (32.1)	1.027 (26.1)	.957 (24.3)	.125 (3.2)	.250 (6.4)	4
4	10	.761 (19.3)	1.982 (50.3)	1.027 (26.1)	.957 (24.3)	.125 (3.2)	.312 (7.9)	4
5	10	.761 (19.3)	1.382 (35.1)	1.027 (26.1)	1.145 (29.1)	.250 (6.4)	.375 (9.5)	6
6	12	.766 (19.5)	2.002 (50.9)	1.027 (26.1)	.957 (24.3)	.125 (3.2)	.312 (7.9)	4
7	12	.766 (19.5)	2.002 (50.9)	1.027 (26.1)	1.145 (29.1)	.250 (6.4)	.437 (11.1)	6
8	12	.766 (19.5)	1.397 (35.5)	1.027 (26.1)	1.332 (33.8)	.350 (8.9)	.500 (12.7)	10
9	14	.866 (22.0)	2.072 (52.6)	1.027 (26.1)	1.145 (29.1)	.250 (6.4)	.437 (11.1)	6
10	14	.866 (22.0)	1.717 (43.6)	1.027 (26.1)	1.332 (33.8)	.350 (8.9)	.575 (14.6)	10
11	16	1.051 (26.7)	2.162 (54.9)	1.027 (26.1)	1.145 (29.1)	.250 (6.4)	.437 (11.1)	6
12	16	1.051 (26.7)	1.807 (45.9)	1.059 (26.9)	1.551 (39.4)	.500 (12.7)	.700 (17.8)	12
13	18	1.141 (29.0)	2.332 (59.2)	1.027 (26.1)	1.332 (33.8)	.350 (8.9)	.625 (15.9)	10
14	18	1.141 (29.0)	1.982 (50.3)	1.156 (29.4)	1.770 (45.0)	.625 (15.9)	.779 (19.8)	16
15	20	1.141 (29.0)	2.332 (59.2)	1.027 (26.1)	1.332 (33.8)	.350 (8.9)	.625 (15.9)	10
16	20	1.141 (29.0)	1.982 (50.3)	1.156 (29.4)	1.770 (45.0)	.625 (15.9)	.904 (23.0)	16
17	22	1.291 (32.8)	2.442 (62.0)	1.059 (26.9)	1.551 (39.4)	.500 (12.7)	.750 (19.1)	12
18	22	1.291 (32.8)	2.087 (53.0)	1.375 (34.9)	2.113 (53.7)	.875 (22.2)	1.029 (26.1)	20
19	24	1.291 (32.8)	2.442 (62.0)	1.059 (26.9)	1.551 (39.4)	.500 (12.7)	.750 (19.1)	12
20	24	1.291 (32.8)	2.087 (53.0)	1.375 (34.9)	2.113 (53.7)	.875 (22.2)	1.144 (29.1)	20
21	28	1.391 (35.3)	2.612 (66.3)	1.156 (33.7)	1.770 (45.0)	.625 (15.9)	.937 (23.8)	16

Table Continued on Page B-26

Dimensions in inches (millimeters) and are subject to change without notice.



AS85049/9 and MS3188B 90° Environmental Backshell

TABLE II: Dash Number and Cable Range (Continued From Page B-25)

Dash No.	Shell Size	H		J		K		L		Cable Range		M85049/42 Ref.
		Max		Max		Ref.		Max		Min	Max	
22	28	1.391 (35.3)		2.257 (57.3)		1.500 (38.1)		2.363 (60.0)		1.000 (25.4)	1.375 (34.9)	24
23	32	1.741 (44.2)		2.862 (72.7)		1.156 (29.4)		1.770 (45.0)		.625 (15.9)	.937 (23.8)	16
24	32	1.741 (44.2)		2.862 (72.7)		1.375 (34.9)		2.113 (53.7)		.875 (22.2)	1.250 (31.8)	20
25	32	1.741 (44.2)		2.507 (63.7)		1.781 (45.2)		2.770 (70.4)		1.250 (31.8)	1.625 (41.3)	28
26	36	1.941 (49.3)		2.832 (71.9)		1.156 (29.4)		1.770 (45.0)		.625 (15.9)	.937 (23.8)	16
27	36	1.941 (49.3)		2.832 (71.9)		1.500 (38.1)		2.363 (60.0)		1.000 (25.4)	1.375 (34.9)	24
28	36	1.941 (49.3)		2.477 (62.9)		1.830 (46.5)		3.020 (76.7)		1.437 (36.5)	1.840 (46.7)	32
29	40	2.691 (68.4)		2.832 (71.9)		1.156 (29.4)		1.770 (45.0)		.625 (15.9)	.937 (23.8)	16
30	40	2.691 (68.4)		2.832 (71.9)		1.500 (38.1)		2.363 (60.0)		1.000 (25.4)	1.375 (34.9)	24
31	40	2.691 (68.4)		2.477 (62.9)		1.830 (46.5)		3.020 (76.7)		1.437 (36.5)	1.875 (47.6)	32
32	44	2.691 (68.4)		2.832 (71.9)		1.156 (29.4)		1.770 (45.0)		.625 (15.9)	.937 (23.8)	16
33	44	2.691 (68.4)		2.832 (71.9)		1.500 (38.1)		2.363 (60.0)		1.000 (25.4)	1.375 (34.9)	24
34	44	2.691 (68.4)		2.477 (62.9)		1.830 (46.5)		3.020 (76.7)		1.437 (36.5)	1.875 (47.6)	32
35	48	2.691 (68.4)		2.832 (71.9)		1.156 (29.4)		1.770 (45.0)		.625 (15.9)	.937 (23.8)	16
36	48	2.691 (68.4)		2.832 (71.9)		1.500 (38.1)		2.363 (60.0)		1.000 (25.4)	1.375 (34.9)	24
37	48	2.691 (68.4)		2.477 (62.9)		1.830 (46.5)		3.020 (76.7)		1.437 (36.5)	1.875 (47.6)	32
38	61	1.291 (32.8)		2.442 (62.0)		1.059 (26.9)		1.551 (39.4)		.500 (12.7)	.750 (19.1)	12
39	61	1.291 (32.8)		2.087 (53.0)		1.375 (34.9)		2.113 (53.7)		.875 (22.2)	1.184 (30.1)	20
40	16	1.051 (26.7)		2.162 (54.9)		1.027 (26.1)		1.332 (33.8)		.350 (8.9)	.625 (15.9)	10
41	18	1.141 (29.0)		2.332 (59.2)		1.027 (26.1)		.957 (24.3)		.125 (3.2)	.312 (7.9)	4
42	18	1.141 (29.0)		2.332 (59.2)		1.027 (26.1)		1.145 (29.1)		.250 (6.4)	.437 (11.1)	6
43	20	1.141 (29.0)		2.332 (59.2)		1.027 (26.1)		1.145 (29.1)		.250 (6.4)	.437 (11.1)	6
44	22	1.291 (32.8)		2.442 (62.0)		1.027 (26.1)		.957 (24.3)		.125 (3.2)	.312 (7.9)	4
45	22	1.291 (32.8)		2.442 (62.0)		1.027 (26.1)		1.145 (29.1)		.250 (6.4)	.437 (11.1)	6
46	24	1.291 (32.8)		2.442 (62.0)		1.027 (26.1)		1.332 (33.8)		.350 (8.9)	.625 (15.9)	10
47	36	1.941 (49.3)		2.832 (71.9)		1.059 (26.9)		1.551 (39.4)		.500 (12.7)	.750 (19.1)	12
48	40	1.941 (49.3)		2.832 (71.9)		1.059 (26.9)		1.551 (39.4)		.500 (12.7)	.750 (19.1)	12
49*	10	1.516 (38.5)		2.002 (50.9)		1.027 (26.1)		1.145 (29.1)		.250 (6.4)	.437 (11.1)	6
50*	14	1.891 (48.0)		2.332 (59.2)		1.059 (26.9)		1.551 (39.4)		.500 (12.7)	.750 (19.1)	12
51*	16	2.041 (51.8)		2.442 (62.0)		1.156 (29.4)		1.770 (45.0)		.625 (15.9)	.937 (23.8)	16
52	18	1.141 (29.0)		2.332 (59.2)		1.059 (26.9)		1.551 (39.4)		.500 (12.7)	.750 (19.1)	12
53	61	1.291 (32.8)		2.087 (53.0)		1.156 (29.4)		1.770 (45.0)		.625 (15.9)	.937 (23.8)	16
54	20	1.141 (29.0)		2.332 (59.2)		1.059 (26.9)		1.551 (39.4)		.500 (12.7)	.750 (19.1)	12
55*	20	2.141 (54.4)		2.612 (66.3)		1.375 (34.9)		2.113 (53.7)		.875 (22.2)	1.250 (31.8)	20
56	22	1.291 (32.8)		2.442 (62.0)		1.027 (26.1)		1.332 (33.8)		.350 (8.9)	.625 (15.9)	10
57	22	1.291 (32.8)		2.442 (62.0)		1.156 (29.4)		1.770 (45.0)		.625 (15.9)	.937 (23.8)	16
58*	22	2.141 (54.4)		2.612 (66.3)		1.375 (34.9)		2.113 (53.7)		.875 (22.2)	1.250 (31.8)	20
59	24	1.291 (32.8)		2.442 (62.0)		1.156 (29.4)		1.770 (45.0)		.625 (15.9)	.937 (23.8)	16
60	28	1.391 (35.3)		2.612 (66.3)		1.059 (26.9)		1.551 (39.4)		.500 (12.7)	.750 (19.1)	12
61	28	1.391 (35.3)		2.612 (66.3)		1.375 (34.9)		2.113 (53.7)		.875 (22.2)	1.250 (31.8)	20
62	32	1.741 (44.2)		2.862 (72.7)		1.500 (38.1)		2.363 (60.0)		1.000 (25.4)	1.375 (34.9)	24
63	36	1.941 (49.3)		2.832 (71.9)		1.375 (34.9)		2.113 (53.7)		.875 (22.2)	1.250 (31.8)	20
64	36	1.941 (49.3)		2.832 (71.9)		1.781 (45.2)		2.770 (70.4)		1.250 (31.8)	1.625 (41.3)	28
65	40	2.691 (68.4)		2.832 (71.9)		1.375 (34.9)		2.113 (53.7)		.875 (22.2)	1.250 (31.8)	20
66	40	2.691 (68.4)		2.832 (71.9)		1.781 (45.2)		2.770 (70.4)		1.250 (31.8)	1.625 (41.3)	28
67	44	2.691 (68.4)		2.832 (71.9)		1.375 (34.9)		2.113 (53.7)		.875 (22.2)	1.250 (31.8)	20
68	44	2.691 (68.4)		2.832 (71.9)		1.781 (45.2)		2.770 (70.4)		1.250 (31.8)	1.625 (41.3)	28
69	48	2.691 (68.4)		2.832 (71.9)		1.375 (34.9)		2.113 (53.7)		.875 (22.2)	1.250 (31.8)	20
70	48	2.691 (68.4)		2.832 (71.9)		1.781 (45.2)		2.770 (70.4)		1.250 (31.8)	1.625 (41.3)	28
71*	12	1.811 (46.0)		2.162 (54.9)		1.027 (26.1)		1.332 (33.8)		.350 (8.9)	.625 (15.9)	10
72*	18	2.051 (52.1)		2.442 (62.0)		1.156 (29.4)		1.770 (45.0)		.625 (15.9)	.937 (23.8)	16
73*	24	2.151 (54.6)		2.612 (66.3)		1.375 (34.9)		2.116 (53.7)		.875 (22.2)	1.250 (31.8)	20
74	14	.866 (22.0)		2.072 (52.6)		1.027 (26.1)		.957 (24.3)		.125 (3.2)	.312 (7.9)	4
75	16	1.051 (26.7)		2.162 (54.9)		1.027 (26.1)		.957 (24.3)		.125 (3.2)	.312 (7.9)	4

Dimensions in inches (millimeters) and are subject to change without notice.

AS85049/10 and MS3437A Straight EMI/RFI Environmental Backshell



AS85049

B

CONNECTOR DESIGNATOR:	
A	AS50151 Series AS34001
	MIL-DTL-26482 Series II
	AS81703 Series III
	MIL-DTL-83723 Series I & III
	40M39569, DEF 5326-3, EN 2997
	EN 3646, ESC 10, ESC 11, LN 29504
	NFC93422 Series HE302
	PAN 6432-1, PAN 6432-2, PATT 602

Basic Part Number Dash Number (Table I)

M85049/10 - 21 W

Superseded Part Number	
MS3437A 21 C	
Basic Part No.	Dash No.
Finish (Material is Aluminum Only) A = Cadmium Olive Drab over Nickel C = Cadmium Olive Drab N = Electroless Nickel	

Finish / Material
B = Black Cadmium / Stainless Steel
N = Electroless Nickel / Aluminum
S = Passivated / Stainless Steel
W = 1,000 Hr. Cadmium Olive Drab over Electroless Nickel / Aluminum
X = Aluminum, Nickel Fluorocarbon Polymer
Z = Aluminum, Zinc-Nickel, Black
XS = Stainless Steel, Nickel Fluorocarbon Polymer
ZS = Stainless Steel, Zinc-Nickel, Black

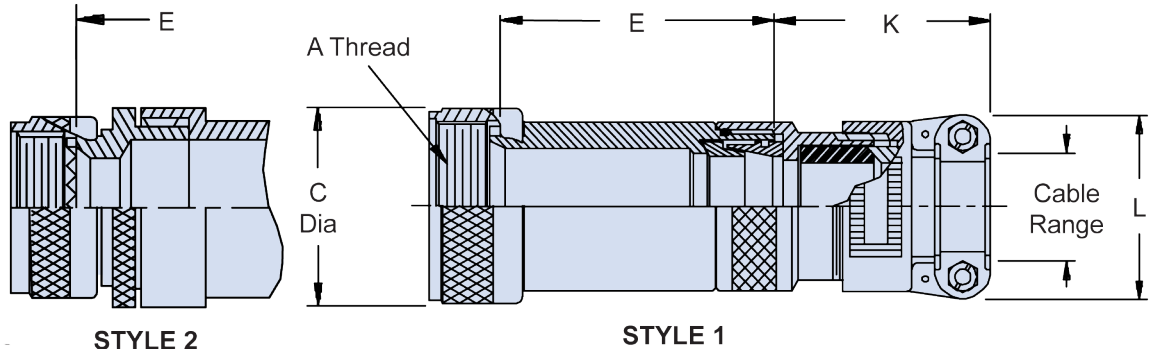

Shell Size	A Thread Class 2B	C Dia Max
3	.562 - 24 UNEF	.67 (17.0)
8	.500 - 20 UNF	.62 (15.7)
10	.625 - 24 UNEF	.73 (18.5)
12	.750 - 20 UNEF	.86 (21.8)
14	.875 - 20 UNEF	.98 (24.9)
16	1.000 - 20 UNEF	1.11 (28.2)
18	1.062 - 18 UNEF	1.22 (31.0)
20	1.188 - 18 UNEF	1.34 (34.0)
22	1.313 - 18 UNEF	1.47 (37.3)
24	1.438 - 18 UNEF	1.59 (40.4)
28	1.750 - 18 UNS	1.97 (50.0)
32	2.000 - 18 UNS	2.22 (56.4)
36	2.250 - 16 UN	2.47 (62.7)
40	2.500 - 16 UN	2.72 (69.1)
44	2.750 - 16 UN	2.97 (75.4)
48	3.000 - 16 UN	3.22 (81.8)
61	1.500 - 18 UNEF	1.65 (41.9)

APPLICATION NOTES

- For complete dimensions see the applicable Military Specification.
- Metric dimensions (mm) are in parentheses.
- Cable Range is defined as the accommodation range for the wire bundle or cable. Dimensions shown are not intended for inspection criteria.

Dimensions in inches (millimeters) and are subject to change without notice.



AS85049/10 and MS3437A Straight EMI/RFI Environmental Backshell

TABLE II: Dash No., Style, Shell Size, Dimensions and Cable Range

Dash No.	Shell Size	Style	E		K		L		Cable Range		M85049/42 Ref.
			Max		Ref		Max		Min	Max	
01	3	1	2.125 (54.0)		1.544 (39.2)		.957 (24.3)		.125 (3.2)	.250 (6.4)	4
02	3	1	3.125 (79.4)		1.544 (39.2)		.957 (24.3)		.125 (3.2)	.250 (6.4)	4
03	3	2	2.875 (73.0)		1.544 (39.2)		1.145 (29.1)		.250 (6.4)	.437 (11.1)	6
04	3	2	3.875 (98.4)		1.544 (39.2)		1.145 (29.1)		.250 (6.4)	.437 (11.1)	6
05	8	1	2.125 (54.0)		1.544 (39.2)		.957 (24.3)		.125 (3.2)	.250 (6.4)	4
06	8	1	3.125 (79.4)		1.544 (39.2)		.957 (24.3)		.125 (3.2)	.250 (6.4)	4
07	8	2	2.875 (73.0)		1.544 (39.2)		1.145 (29.1)		.250 (6.4)	.437 (11.1)	6
08	8	2	3.875 (98.4)		1.544 (39.2)		1.145 (29.1)		.250 (6.4)	.437 (11.1)	6
09	10	1	2.125 (54.0)		1.544 (39.2)		.957 (24.3)		.125 (3.2)	.312 (7.9)	4
10	10	1	3.125 (79.4)		1.544 (39.2)		.957 (24.3)		.125 (3.2)	.312 (7.9)	4
11	10	2	2.875 (73.0)		1.544 (39.2)		1.145 (29.1)		.250 (6.4)	.437 (11.1)	6
12	10	2	3.875 (98.4)		1.544 (39.2)		1.145 (29.1)		.250 (6.4)	.437 (11.1)	6
13	12	1	2.125 (54.0)		1.544 (39.2)		1.145 (29.1)		.250 (6.4)	.437 (11.1)	6
14	12	1	3.125 (79.4)		1.544 (39.2)		1.145 (29.1)		.250 (6.4)	.437 (11.1)	6
15	12	2	2.875 (73.0)		1.844 (46.8)		1.332 (33.8)		.350 (8.9)	.625 (15.9)	10
16	12	2	3.875 (98.4)		1.844 (46.8)		1.332 (33.8)		.350 (8.9)	.625 (15.9)	10
17	14	1	2.125 (54.0)		1.844 (46.8)		1.332 (33.8)		.350 (8.9)	.575 (14.6)	10
18	14	1	3.125 (79.4)		1.844 (46.8)		1.332 (33.8)		.350 (8.9)	.575 (14.6)	10
19	14	2	2.875 (73.0)		1.916 (48.7)		1.551 (39.4)		.500 (12.7)	.750 (19.1)	12
20	14	2	3.875 (98.4)		1.916 (48.7)		1.551 (39.4)		.500 (12.7)	.750 (19.1)	12
21	16	1	2.125 (54.0)		1.916 (48.7)		1.551 (39.4)		.500 (12.7)	.700 (17.8)	12
22	16	1	3.125 (79.4)		1.916 (48.7)		1.551 (39.4)		.500 (12.7)	.700 (17.8)	12
23	16	2	2.875 (73.0)		2.000 (50.8)		1.770 (45.0)		.625 (15.9)	.937 (23.8)	16
24	16	2	3.875 (98.4)		2.000 (50.8)		1.770 (45.0)		.625 (15.9)	.937 (23.8)	16
25	18	1	2.125 (54.0)		1.844 (46.8)		1.332 (33.8)		.350 (8.9)	.625 (15.9)	10
26	18	1	3.125 (79.4)		1.844 (46.8)		1.332 (33.8)		.350 (8.9)	.625 (15.9)	10
27	18	1	2.125 (54.0)		1.916 (48.7)		1.551 (39.4)		.500 (12.7)	.750 (19.1)	12
28	18	1	3.125 (79.4)		1.916 (48.7)		1.551 (39.4)		.500 (12.7)	.750 (19.1)	12
29	18	2	2.875 (73.0)		2.000 (50.8)		1.770 (45.0)		.625 (15.9)	.937 (23.8)	16
30	18	2	3.875 (98.4)		2.000 (50.8)		1.770 (45.0)		.625 (15.9)	.937 (23.8)	16
31	20	1	3.125 (79.4)		1.844 (46.8)		1.332 (33.8)		.350 (8.9)	.625 (15.9)	10
32	20	1	4.125 (104.8)		1.844 (46.8)		1.332 (33.8)		.350 (8.9)	.625 (15.9)	10
33	20	1	3.125 (79.4)		1.916 (48.7)		1.551 (39.4)		.500 (12.7)	.750 (19.1)	12
34	20	1	4.125 (104.8)		1.916 (48.7)		1.551 (39.4)		.500 (12.7)	.750 (19.1)	12
35	20	2	3.875 (98.4)		2.000 (50.8)		1.770 (45.0)		.625 (15.9)	.937 (23.8)	16
36	20	2	4.875 (123.8)		2.000 (50.8)		1.770 (45.0)		.625 (15.9)	.937 (23.8)	16
37	20	2	3.875 (98.4)		2.230 (56.6)		2.113 (53.7)		.875 (22.2)	1.250 (31.8)	20
38	20	2	4.875 (123.8)		2.230 (56.6)		2.113 (53.7)		.875 (22.2)	1.250 (31.8)	20
39	22	1	3.125 (79.4)		1.844 (46.8)		1.332 (33.8)		.350 (8.9)	.625 (15.9)	10
40	22	1	4.125 (104.8)		1.844 (46.8)		1.332 (33.8)		.350 (8.9)	.625 (15.9)	10
41	22	1	3.125 (79.4)		1.916 (48.7)		1.551 (39.4)		.500 (12.7)	.750 (19.1)	12
42	22	1	4.125 (104.8)		1.916 (48.7)		1.551 (39.4)		.500 (12.7)	.750 (19.1)	12
43	22	1	3.125 (79.4)		2.000 (50.8)		1.770 (45.0)		.625 (15.9)	.937 (23.8)	16
44	22	1	4.125 (104.8)		2.000 (50.8)		1.770 (45.0)		.625 (15.9)	.937 (23.8)	16
45	22	2	3.875 (98.4)		2.230 (56.6)		2.113 (53.7)		.875 (22.2)	1.250 (31.8)	20
46	22	2	4.875 (123.8)		2.230 (56.6)		2.113 (53.7)		.875 (22.2)	1.250 (31.8)	20
47	24	1	3.125 (79.4)		1.916 (48.7)		1.551 (39.4)		.500 (12.7)	.750 (19.1)	12
48	24	1	4.125 (104.8)		1.916 (48.7)		1.551 (39.4)		.500 (12.7)	.750 (19.1)	12
49	24	1	3.125 (79.4)		2.000 (50.8)		1.770 (45.0)		.625 (15.9)	.812 (20.6)	16
50	24	1	4.125 (104.8)		2.000 (50.8)		1.770 (45.0)		.625 (15.9)	.812 (20.6)	16
51	24	1	3.125 (79.4)		2.000 (50.8)		1.770 (45.0)		.625 (15.9)	.937 (23.8)	16
52	24	1	4.125 (104.8)		2.000 (50.8)		1.770 (45.0)		.625 (15.9)	.937 (23.8)	16

Continued on Page B-29

Dimensions in inches (millimeters) and are subject to change without notice.

AS85049/10 and MS3437A Straight EMI/RFI Environmental Backshell



AS85049

B

TABLE II: (Continued from Page B-28)

Dash No.	Shell Size	Style	E Max	K Ref	L Max	Cable Range		M85049/42 Ref.
						Min	Max	
53	24	2	3.875 (98.4)	2.230 (56.6)	2.113 (53.7)	.875 (22.2)	1.250 (31.8)	20
54	24	2	4.875 (123.8)	2.230 (56.6)	2.113 (53.7)	.875 (22.2)	1.250 (31.8)	20
55	28	1	3.125 (79.4)	1.916 (48.7)	1.551 (39.4)	.500 (12.7)	.750 (19.1)	12
56	28	1	4.125 (104.8)	1.916 (48.7)	1.551 (39.4)	.500 (12.7)	.750 (19.1)	12
57	28	1	3.125 (79.4)	2.000 (50.8)	1.770 (45.0)	.625 (15.9)	.937 (23.8)	16
58	28	1	4.125 (104.8)	2.000 (50.8)	1.770 (45.0)	.625 (15.9)	.937 (23.8)	16
59	28	1	3.125 (79.4)	2.230 (56.6)	2.113 (53.7)	.875 (22.2)	1.250 (31.8)	20
60	28	1	4.125 (104.8)	2.230 (56.6)	2.113 (53.7)	.875 (22.2)	1.250 (31.8)	20
61	28	1	3.125 (79.4)	2.024 (51.4)	2.363 (60.0)	1.000 (25.4)	1.375 (34.9)	24
62	28	1	4.126 (104.8)	2.024 (51.4)	2.363 (60.0)	1.000 (25.4)	1.375 (34.9)	24
63	32	1	3.125 (79.4)	2.000 (50.8)	1.770 (45.0)	.625 (15.9)	.937 (23.8)	16
64	32	1	4.125 (104.8)	2.000 (50.8)	1.770 (45.0)	.625 (15.9)	.937 (23.8)	16
65	32	1	3.125 (79.4)	2.230 (56.6)	2.113 (53.7)	.875 (22.2)	1.250 (31.8)	20
66	32	1	4.125 (104.8)	2.230 (56.6)	2.113 (53.7)	.875 (22.2)	1.250 (31.8)	20
67	32	1	3.125 (79.4)	2.024 (51.4)	2.363 (60.0)	1.000 (25.4)	1.375 (34.9)	24
68	32	1	4.125 (104.8)	2.024 (51.4)	2.363 (60.0)	1.000 (25.4)	1.375 (34.9)	24
69	32	1	3.125 (79.4)	2.550 (64.8)	2.770 (70.4)	1.250 (31.8)	1.625 (41.3)	28
70	32	1	4.125 (104.8)	2.550 (64.8)	2.770 (70.4)	1.250 (31.8)	1.625 (41.3)	28
71	36	1	4.125 (104.8)	2.230 (56.6)	2.113 (53.7)	.875 (22.2)	1.250 (31.8)	20
72	36	1	5.125 (130.2)	2.230 (56.6)	2.113 (53.7)	.875 (22.2)	1.250 (31.8)	20
73	36	1	4.125 (104.8)	2.024 (51.4)	2.363 (60.0)	1.000 (25.4)	1.375 (34.9)	24
74	36	1	5.125 (130.2)	2.024 (51.4)	2.363 (60.0)	1.000 (25.4)	1.375 (34.9)	24
75	36	1	4.125 (104.8)	2.550 (64.8)	2.770 (70.4)	1.250 (31.8)	1.625 (41.3)	28
76	36	1	5.125 (130.2)	2.550 (64.8)	2.770 (70.4)	1.250 (31.8)	1.625 (41.3)	28
77	36	2	5.000 (127.0)	2.600 (66.0)	3.020 (76.7)	1.437 (36.5)	1.875 (47.6)	32
78	36	2	6.000 (152.4)	2.600 (66.0)	3.020 (76.7)	1.437 (36.5)	1.875 (47.6)	32
79	40	1	4.125 (104.8)	2.230 (56.6)	2.113 (53.7)	.875 (22.2)	1.250 (31.8)	20
80	40	1	5.125 (130.2)	2.230 (56.6)	2.113 (53.7)	.875 (22.2)	1.250 (31.8)	20
81	40	1	4.125 (104.8)	2.024 (51.4)	2.363 (60.0)	1.000 (25.4)	1.375 (34.9)	24
82	40	1	5.125 (130.2)	2.024 (51.4)	2.363 (60.0)	1.000 (25.4)	1.375 (34.9)	24
83	40	1	4.125 (104.8)	2.550 (64.8)	2.770 (70.4)	1.250 (31.8)	1.625 (41.3)	28
84	40	1	5.125 (130.2)	2.550 (64.8)	2.770 (70.4)	1.250 (31.8)	1.625 (41.3)	28
85	40	1	4.125 (104.8)	2.600 (66.0)	3.020 (76.7)	1.437 (36.5)	1.875 (47.6)	32
86	40	1	5.125 (130.2)	2.600 (66.0)	3.020 (76.7)	1.437 (36.5)	1.875 (47.6)	32
87	44	1	4.125 (104.8)	2.230 (56.6)	2.113 (53.7)	.875 (22.2)	1.250 (31.8)	20
88	44	1	5.125 (130.2)	2.230 (56.6)	2.113 (53.7)	.875 (22.2)	1.250 (31.8)	20
89	44	1	4.125 (104.8)	2.024 (51.4)	2.363 (60.0)	1.000 (25.4)	1.375 (34.9)	24
90	44	1	5.125 (130.2)	2.024 (51.4)	2.363 (60.0)	1.000 (25.4)	1.375 (34.9)	24
91	44	1	4.125 (104.8)	2.550 (64.8)	2.770 (70.4)	1.250 (31.8)	1.625 (41.3)	28
92	44	1	5.125 (130.2)	2.550 (64.8)	2.770 (70.4)	1.250 (31.8)	1.625 (41.3)	28
93	44	1	4.125 (104.8)	2.600 (66.0)	3.020 (76.7)	1.437 (36.5)	1.875 (47.6)	32
94	44	1	5.125 (130.2)	2.600 (66.0)	3.020 (76.7)	1.437 (36.5)	1.875 (47.6)	32
95	48	1	4.125 (104.8)	2.230 (56.6)	2.113 (53.7)	.875 (22.2)	1.250 (31.8)	20
96	48	1	5.125 (130.2)	2.230 (56.6)	2.113 (53.7)	.875 (22.2)	1.250 (31.8)	20
97	48	1	4.125 (104.8)	2.024 (51.4)	2.363 (60.0)	1.000 (25.4)	1.375 (34.9)	24
98	48	1	5.125 (130.2)	2.024 (51.4)	2.363 (60.0)	1.000 (25.4)	1.375 (34.9)	24
99	48	1	4.125 (104.8)	2.550 (64.8)	2.770 (70.4)	1.250 (31.8)	1.625 (41.3)	28
100	48	1	5.125 (130.2)	2.550 (64.8)	2.770 (70.4)	1.250 (31.8)	1.625 (41.3)	28
101	48	1	4.125 (104.8)	2.600 (66.0)	3.020 (76.7)	1.437 (36.5)	1.875 (47.6)	32
102	48	1	5.125 (130.2)	2.600 (66.0)	3.020 (76.7)	1.437 (36.5)	1.875 (47.6)	32
103	61	1	3.125 (79.4)	1.916 (48.7)	1.551 (39.4)	.500 (12.7)	.750 (19.1)	12
104	61	1	4.125 (104.8)	1.916 (48.7)	1.551 (39.4)	.500 (12.7)	.750 (19.1)	12

Continued on Page B-30

Dimensions in inches (millimeters) and are subject to change without notice.

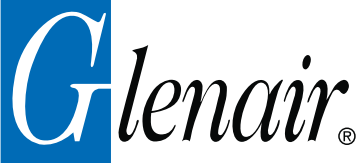

AS85049/10 and MS3437A Straight EMI/RFI Environmental Backshell

TABLE II: (Continued from Page B-29)

Dash No.	Shell Size	Style	E Max	K Ref	L Max	Cable Range		M85049/42 Ref.
						Min	Max	
105	61	1	3.125 (79.4)	2.000 (50.8)	1.770 (45.0)	.625 (15.9)	.937 (23.8)	16
106	61	1	4.125 (104.8)	2.000 (50.8)	1.770 (45.0)	.625 (15.9)	.937 (23.8)	16
107	61	2	3.875 (98.4)	2.230 (56.6)	2.113 (53.7)	.875 (22.2)	1.250 (31.8)	20
108	61	2	4.875 (123.8)	2.230 (56.6)	2.113 (53.7)	.875 (22.2)	1.250 (31.8)	20
109	61	2	3.875 (98.4)	2.024 (51.4)	2.363 (60.0)	1.000 (25.4)	1.375 (34.9)	24
110	61	2	4.875 (123.8)	2.024 (51.4)	2.363 (60.0)	1.000 (25.4)	1.375 (34.9)	24
111	12	1	2.125 (54.0)	1.844 (46.8)	1.332 (33.8)	.350 (8.9)	.500 (12.7)	10
112	16	1	2.125 (54.0)	1.544 (39.2)	1.145 (29.1)	.250 (6.4)	.437 (11.1)	6
113	16	1	3.125 (79.4)	1.544 (39.2)	1.145 (29.1)	.250 (6.4)	.437 (11.1)	6
114	12	1	2.125 (54.0)	1.544 (39.2)	.957 (24.3)	.125 (3.2)	.312 (7.9)	4
115	12	1	3.125 (79.4)	1.544 (39.2)	.957 (24.3)	.125 (3.2)	.312 (7.9)	4
116	14	1	2.125 (54.0)	1.544 (39.2)	1.145 (29.1)	.250 (6.4)	.437 (11.1)	6
117	14	1	3.125 (79.4)	1.544 (39.2)	1.145 (29.1)	.250 (6.4)	.437 (11.1)	6
118	16	1	2.125 (54.0)	1.844 (46.8)	1.332 (33.8)	.350 (8.9)	.625 (15.9)	10
119	16	1	3.125 (79.4)	1.844 (46.8)	1.332 (33.8)	.350 (8.9)	.625 (15.9)	10
120	18	1	2.125 (54.0)	1.544 (39.2)	.957 (24.3)	.125 (3.2)	.312 (7.9)	4
121	18	1	3.125 (79.4)	1.544 (39.2)	.957 (24.3)	.125 (3.2)	.312 (7.9)	4
122	18	1	2.125 (54.0)	1.544 (39.2)	1.145 (29.1)	.250 (6.4)	.437 (11.1)	6
123	18	1	3.125 (79.4)	1.544 (39.2)	1.145 (29.1)	.250 (6.4)	.437 (11.1)	6
124	20	1	3.125 (79.4)	1.544 (39.2)	1.145 (29.1)	.250 (6.4)	.437 (11.1)	6
125	20	1	4.125 (104.8)	1.544 (39.2)	1.145 (29.1)	.250 (6.4)	.437 (11.1)	6
126	22	1	3.125 (79.4)	1.544 (39.2)	.957 (24.3)	.125 (3.2)	.312 (7.9)	4
127	22	1	4.125 (104.8)	1.544 (39.2)	.957 (24.3)	.125 (3.2)	.312 (7.9)	4
128	22	1	3.125 (79.4)	1.544 (39.2)	1.145 (29.1)	.250 (6.4)	.437 (11.1)	6
129	22	1	4.125 (104.8)	1.544 (39.2)	1.145 (29.1)	.250 (6.4)	.437 (11.1)	6
130	24	1	3.125 (79.4)	1.844 (46.8)	1.332 (33.8)	.350 (8.9)	.625 (15.9)	10
131	24	1	4.125 (104.8)	1.844 (46.8)	1.332 (33.8)	.350 (8.9)	.625 (15.9)	10
132	36	1	4.125 (104.8)	1.916 (48.7)	1.551 (39.4)	.500 (12.7)	.750 (19.1)	12
133	36	1	5.125 (130.2)	1.916 (48.7)	1.551 (39.4)	.500 (12.7)	.750 (19.1)	12
134	40	1	4.125 (104.8)	1.916 (48.7)	1.551 (39.4)	.500 (12.7)	.750 (19.1)	12
135	40	1	5.125 (130.2)	1.916 (48.7)	1.551 (39.4)	.500 (12.7)	.750 (19.1)	12
136	10	1	2.125 (54.0)	1.544 (39.2)	1.145 (29.1)	.250 (6.4)	.375 (9.5)	6
137	10	1	3.125 (79.4)	1.544 (39.2)	1.145 (29.1)	.250 (6.4)	.375 (9.5)	6
138	12	1	2.125 (54.0)	1.844 (46.8)	1.332 (33.8)	.350 (8.9)	.500 (12.7)	10
139	12	1	3.125 (79.4)	1.844 (46.8)	1.332 (33.8)	.350 (8.9)	.500 (12.7)	10
140	20	1	3.125 (79.4)	2.000 (50.8)	1.770 (45.0)	.625 (15.9)	.904 (23.0)	16
141	20	1	4.125 (104.8)	2.000 (50.8)	1.770 (45.0)	.625 (15.9)	.904 (23.0)	16
142	22	1	3.125 (79.4)	2.230 (56.6)	2.113 (53.7)	.875 (22.2)	1.029 (26.1)	20
143	22	1	4.125 (104.8)	2.230 (56.6)	2.113 (53.7)	.875 (22.2)	1.029 (26.1)	20
144	24	1	3.125 (79.4)	2.230 (56.6)	2.113 (53.7)	.875 (22.2)	1.144 (29.1)	20
145	24	1	4.125 (104.8)	2.230 (56.6)	2.113 (53.7)	.875 (22.2)	1.144 (29.1)	20
146	36	1	4.125 (104.8)	2.600 (66.0)	3.020 (76.7)	1.437 (36.5)	1.840 (46.7)	32
147	36	1	5.125 (130.2)	2.600 (66.0)	3.020 (76.7)	1.437 (36.5)	1.840 (46.7)	32
148	36	1	4.125 (104.8)	2.000 (50.8)	1.770 (45.0)	.625 (15.9)	.937 (23.8)	16
149	36	1	5.125 (130.2)	2.000 (50.8)	1.770 (45.0)	.625 (15.9)	.937 (23.8)	16
150	14	1	2.125 (54.0)	1.544 (39.2)	.957 (24.3)	.125 (3.2)	.312 (7.9)	4
151	14	1	3.125 (79.4)	1.544 (39.2)	.957 (24.3)	.125 (3.2)	.312 (7.9)	4
152	16	1	2.125 (54.0)	1.544 (39.2)	.957 (24.3)	.125 (3.2)	.312 (7.9)	4
153	16	1	3.125 (79.4)	1.544 (39.2)	.957 (24.3)	.125 (3.2)	.312 (7.9)	4
154	44	1	4.125 (104.8)	2.000 (50.8)	1.770 (45.0)	.625 (15.9)	.937 (23.8)	16
155	44	1	5.125 (130.2)	2.000 (50.8)	1.770 (45.0)	.625 (15.9)	.937 (23.8)	16
156	40	1	4.125 (104.8)	2.000 (50.8)	1.770 (45.0)	.625 (15.9)	.937 (23.8)	16
157	40	1	5.125 (130.2)	2.000 (50.8)	1.770 (45.0)	.625 (15.9)	.937 (23.8)	16

Dimensions in inches (millimeters) and are subject to change without notice.

AS85049/11 and MS3437B Straight Environmental Backshell



AS85049

B

CONNECTOR DESIGNATOR:	
A	AS50151 Series AS34001
	MIL-DTL-26482 Series II
	AS81703 Series III
	MIL-DTL-83723 Series I & III
	40M39569, DEF 5326-3, EN 2997
	EN 3646, ESC 10, ESC 11, LN 29504
	NFC93422 Series HE302 PAN 6432-1, PAN 6432-2, PATT 602



Finish / Material

B = Black Cadmium / Stainless Steel
N = Electroless Nickel / Aluminum
S = Passivated / Stainless Steel
W = 1,000 Hr. Cadmium Olive Drab over Electroless Nickel / Aluminum
X = Nickel Fluorocarbon Polymer / Aluminum
Y = Pure Dense Electrodeposited Aluminum / Aluminum
Z = Zinc Nickel, Black / Aluminum
XS = Nickel Fluorocarbon Polymer / Stainless Steel
YS = Pure Dense Electrodeposited Aluminum / Stainless Steel
ZS = Zinc Nickel, Black / Stainless Steel

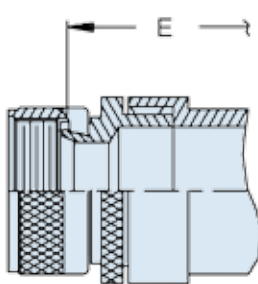

STYLE 2



STYLE 1

TABLE I: Shell Size and Dimensions		
Shell Size	A Thread Class 2B-LH	C Dia Max
3	.562 - 24 UNEF	.669 (17.0)
8	.500 - 20 UNF	.617 (15.7)
10	.625 - 24 UNEF	.734 (18.6)
12	.750 - 20 UNEF	.858 (21.8)
14	.875 - 20 UNEF	.984 (25.0)
16	1.000 - 20 UNEF	1.112 (28.2)
18	1.062 - 18 UNEF	1.218 (30.9)
20	1.188 - 18 UNEF	1.345 (34.2)
22	1.313 - 18 UNEF	1.468 (37.3)
24	1.438 - 18 UNEF	1.593 (40.5)
28	1.750 - 18 UNS	1.969 (50.0)
32	2.000 - 18 UNS	2.219 (56.4)
36	2.250 - 16 UN	2.469 (62.7)
40	2.500 - 16 UN	2.719 (69.1)
44	2.750 - 16 UN	2.969 (75.4)
48	3.000 - 16 UN	3.219 (81.8)
61	1.500 - 18 UNEF	1.653 (42.0)

- APPLICATION NOTES**

 - For complete dimensions see the applicable Military Specification.
 - Metric dimensions (mm) are in parentheses.
 - When maximum cable entry is exceeded, Style 2 will be supplied.
 - Cable Range is defined as the accommodation range for the wire bundle or cable. Dimensions shown are not intended for inspection criteria.

Dimensions in inches (millimeters) and are subject to change without notice.



AS85049/11 and MS3437B Straight Environmental Backshell

TABLE II: Dash Number and Cable Range (Continued on Page B-33)

Dash No.	Shell Size	Style	E Max	K Ref.	L Max	Cable Range		M85049/42 Ref.
						Min	Max	
01	3	1	2.125 (54.0)	1.027 (26.1)	.957 (24.3)	.125 (3.2)	.250 (6.4)	4
02	3	1	3.125 (79.4)	1.027 (26.1)	.957 (24.3)	.125 (3.2)	.250 (6.4)	4
03	3	2	2.875 (73.0)	1.027 (26.1)	1.145 (29.1)	.250 (6.4)	.437 (11.1)	6
04	3	2	3.875 (98.4)	1.027 (26.1)	1.145 (29.1)	.250 (6.4)	.437 (11.1)	6
05	8	1	2.125 (54.0)	1.027 (26.1)	.957 (24.3)	.125 (3.2)	.250 (6.4)	4
06	8	1	3.125 (79.4)	1.027 (26.1)	.957 (24.3)	.125 (3.2)	.250 (6.4)	4
07	8	2	2.875 (73.0)	1.027 (26.1)	1.145 (29.1)	.250 (6.4)	.437 (11.1)	6
08	8	2	3.875 (98.4)	1.027 (26.1)	1.145 (29.1)	.250 (6.4)	.437 (11.1)	6
09	10	1	2.125 (54.0)	1.027 (26.1)	.957 (24.3)	.125 (3.2)	.312 (7.9)	4
10	10	1	3.125 (79.4)	1.027 (26.1)	.957 (24.3)	.125 (3.2)	.312 (7.9)	4
11	10	2	2.875 (73.0)	1.027 (26.1)	1.145 (29.1)	.250 (6.4)	.437 (11.1)	6
12	10	2	3.875 (98.4)	1.027 (26.1)	1.145 (29.1)	.250 (6.4)	.437 (11.1)	6
13	12	1	2.125 (54.0)	1.027 (26.1)	1.145 (29.1)	.250 (6.4)	.437 (11.1)	6
14	12	1	3.125 (79.4)	1.027 (26.1)	1.145 (29.1)	.250 (6.4)	.437 (11.1)	6
15	12	2	2.875 (73.0)	1.027 (26.1)	1.332 (33.8)	.350 (8.9)	.625 (15.9)	10
16	12	2	3.875 (98.4)	1.027 (26.1)	1.332 (33.8)	.350 (8.9)	.625 (15.9)	10
17	14	1	2.125 (54.0)	1.027 (26.1)	1.332 (33.8)	.350 (8.9)	.575 (14.6)	10
18	14	1	3.125 (79.4)	1.027 (26.1)	1.332 (33.8)	.350 (8.9)	.575 (14.6)	10
19	14	2	2.875 (73.0)	1.059 (26.9)	1.551 (39.4)	.500 (12.7)	.750 (19.1)	12
20	14	2	3.875 (98.4)	1.059 (26.9)	1.551 (39.4)	.500 (12.7)	.750 (19.1)	12
21	16	1	2.125 (54.0)	1.059 (26.9)	1.551 (39.4)	.500 (12.7)	.700 (17.8)	12
22	16	1	3.125 (79.4)	1.059 (26.9)	1.551 (39.4)	.500 (12.7)	.700 (17.8)	12
23	16	2	2.875 (73.0)	1.156 (29.4)	1.770 (45.0)	.625 (15.9)	.937 (23.8)	16
24	16	2	3.875 (98.4)	1.156 (29.4)	1.770 (45.0)	.625 (15.9)	.937 (23.8)	16
25	18	1	2.125 (54.0)	1.027 (26.1)	1.332 (33.8)	.350 (8.9)	.625 (15.9)	10
26	18	1	3.125 (79.4)	1.027 (26.1)	1.332 (33.8)	.350 (8.9)	.625 (15.9)	10
27	18	1	2.125 (54.0)	1.059 (26.9)	1.551 (39.4)	.500 (12.7)	.750 (19.1)	12
28	18	1	3.125 (79.4)	1.059 (26.9)	1.551 (39.4)	.500 (12.7)	.750 (19.1)	12
29	18	2	2.875 (73.0)	1.156 (29.4)	1.770 (45.0)	.625 (15.9)	.937 (23.8)	16
30	18	2	3.875 (98.4)	1.156 (29.4)	1.770 (45.0)	.625 (15.9)	.937 (23.8)	16
31	20	1	3.125 (79.4)	1.027 (26.1)	1.332 (33.8)	.350 (8.9)	.625 (15.9)	10
32	20	1	4.125 (104.8)	1.027 (26.1)	1.332 (33.8)	.350 (8.9)	.625 (15.9)	10
33	20	1	3.125 (79.4)	1.059 (26.9)	1.551 (39.4)	.500 (12.7)	.750 (19.1)	12
34	20	1	4.125 (104.8)	1.059 (26.9)	1.551 (39.4)	.500 (12.7)	.750 (19.1)	12
35	20	2	3.875 (98.4)	1.156 (29.4)	1.770 (45.0)	.625 (15.9)	.937 (23.8)	16
36	20	2	4.875 (123.8)	1.156 (29.4)	1.770 (45.0)	.625 (15.9)	.937 (23.8)	16
37	20	2	3.875 (98.4)	1.375 (34.9)	2.113 (53.7)	.875 (22.2)	1.250 (31.8)	20
38	20	2	4.875 (123.8)	1.375 (34.9)	2.113 (53.7)	.875 (22.2)	1.250 (31.8)	20
39	22	1	3.125 (79.4)	1.027 (26.1)	1.332 (33.8)	.350 (8.9)	.625 (15.9)	10
40	22	1	4.125 (104.8)	1.027 (26.1)	1.332 (33.8)	.350 (8.9)	.625 (15.9)	10
41	22	1	3.125 (79.4)	1.059 (26.9)	1.551 (39.4)	.500 (12.7)	.750 (19.1)	12
42	22	1	4.125 (104.8)	1.059 (26.9)	1.551 (39.4)	.500 (12.7)	.750 (19.1)	12
43	22	1	3.125 (79.4)	1.156 (29.4)	1.770 (45.0)	.625 (15.9)	.937 (23.8)	16
44	22	1	4.125 (104.8)	1.156 (29.4)	1.770 (45.0)	.625 (15.9)	.937 (23.8)	16
45	22	2	3.875 (98.4)	1.375 (34.9)	2.113 (53.7)	.875 (22.2)	1.250 (31.8)	20
46	22	2	4.875 (123.8)	1.375 (34.9)	2.113 (53.7)	.875 (22.2)	1.250 (31.8)	20
47	24	1	3.125 (79.4)	1.059 (26.9)	1.551 (39.4)	.500 (12.7)	.750 (19.1)	12
48	24	1	4.125 (104.8)	1.059 (26.9)	1.551 (39.4)	.500 (12.7)	.750 (19.1)	12
49	24	1	3.125 (79.4)	1.156 (29.4)	1.770 (45.0)	.625 (15.9)	.812 (20.6)	16
50	24	1	4.125 (104.8)	1.156 (29.4)	1.770 (45.0)	.625 (15.9)	.812 (20.6)	16
51	24	1	3.125 (79.4)	1.156 (29.4)	1.770 (45.0)	.625 (15.9)	.937 (23.8)	16
52	24	1	4.125 (104.8)	1.156 (29.4)	1.770 (45.0)	.625 (15.9)	.937 (23.8)	16

Continued on Page B-33

Dimensions in inches (millimeters) and are subject to change without notice.

AS85049/11 and MS3437B Straight Environmental Backshell



AS85049

B

TABLE II: Dash Number and Cable Range (Continued From Page B-32)

Dash No.	Shell Size	Style	E Max	K Ref.	L Max	Cable Range		M85049/42 Ref.
						Min	Max	
53	24	2	3.875 (98.4)	1.375 (34.9)	2.113 (53.7)	.875 (22.2)	1.250 (31.8)	20
54	24	2	4.875 (123.8)	1.375 (34.9)	2.113 (53.7)	.875 (22.2)	1.250 (31.8)	20
55	28	1	3.125 (79.4)	1.059 (26.9)	1.551 (39.4)	.500 (12.7)	.750 (19.1)	12
56	28	1	4.125 (104.8)	1.059 (26.9)	1.551 (39.4)	.500 (12.7)	.750 (19.1)	12
57	28	1	3.125 (79.4)	1.156 (29.4)	1.770 (45.0)	.625 (15.9)	.937 (23.8)	16
58	28	1	4.125 (104.8)	1.156 (29.4)	1.770 (45.0)	.625 (15.9)	.937 (23.8)	16
59	28	1	3.125 (79.4)	1.375 (34.9)	2.113 (53.7)	.875 (22.2)	1.250 (31.8)	20
60	28	1	4.125 (104.8)	1.375 (34.9)	2.113 (53.7)	.875 (22.2)	1.250 (31.8)	20
61	28	1	3.125 (79.4)	1.500 (38.1)	2.363 (60.0)	1.000 (25.4)	1.375 (34.9)	24
62	28	1	4.125 (104.8)	1.500 (38.1)	2.363 (60.0)	1.000 (25.4)	1.375 (34.9)	24
63	32	1	3.125 (79.4)	1.156 (29.4)	1.770 (45.0)	.625 (15.9)	.937 (23.8)	16
64	32	1	4.125 (104.8)	1.156 (29.4)	1.770 (45.0)	.625 (15.9)	.937 (23.8)	16
65	32	1	3.125 (79.4)	1.375 (34.9)	2.113 (53.7)	.875 (22.2)	1.250 (31.8)	20
66	32	1	4.125 (104.8)	1.375 (34.9)	2.113 (53.7)	.875 (22.2)	1.250 (31.8)	20
67	32	1	3.125 (79.4)	1.500 (38.1)	2.363 (60.0)	1.000 (25.4)	1.375 (34.9)	24
68	32	1	4.125 (104.8)	1.500 (38.1)	2.363 (60.0)	1.000 (25.4)	1.375 (34.9)	24
69	32	1	3.125 (79.4)	1.781 (45.2)	2.770 (70.4)	1.250 (31.8)	1.625 (41.3)	28
70	32	1	4.125 (104.8)	1.781 (45.2)	2.770 (70.4)	1.250 (31.8)	1.625 (41.3)	28
71	36	1	4.125 (104.8)	1.375 (34.9)	2.113 (53.7)	.875 (22.2)	1.250 (31.8)	20
72	36	1	5.125 (130.2)	1.375 (34.9)	2.113 (53.7)	.875 (22.2)	1.250 (31.8)	20
73	36	1	4.125 (104.8)	1.500 (38.1)	2.363 (60.0)	1.000 (25.4)	1.375 (34.9)	24
74	36	1	5.125 (130.2)	1.500 (38.1)	2.363 (60.0)	1.000 (25.4)	1.375 (34.9)	24
75	36	1	4.125 (104.8)	1.781 (45.2)	2.770 (70.4)	1.250 (31.8)	1.625 (41.3)	28
76	36	1	5.125 (130.2)	1.781 (45.2)	2.770 (70.4)	1.250 (31.8)	1.625 (41.3)	28
77	36	2	5.000 (127.0)	1.830 (46.5)	3.020 (76.7)	1.437 (36.5)	1.875 (47.6)	32
78	36	2	6.000 (152.4)	1.830 (46.5)	3.020 (76.7)	1.437 (36.5)	1.875 (47.6)	32
79	40	1	4.125 (104.8)	1.375 (34.9)	2.113 (53.7)	.875 (22.2)	1.250 (31.8)	20
80	40	1	5.125 (130.2)	1.375 (34.9)	2.113 (53.7)	.875 (22.2)	1.250 (31.8)	20
81	40	1	4.125 (104.8)	1.500 (38.1)	2.363 (60.0)	1.000 (25.4)	1.375 (34.9)	24
82	40	1	5.125 (130.2)	1.500 (38.1)	2.363 (60.0)	1.000 (25.4)	1.375 (34.9)	24
83	40	1	4.125 (104.8)	1.781 (45.2)	2.770 (70.4)	1.250 (31.8)	1.625 (41.3)	28
84	40	1	5.125 (130.2)	1.781 (45.2)	2.770 (70.4)	1.250 (31.8)	1.625 (41.3)	28
85	40	1	4.125 (104.8)	1.830 (46.5)	3.020 (76.7)	1.437 (36.5)	1.875 (47.6)	32
86	40	1	5.125 (130.2)	1.830 (46.5)	3.020 (76.7)	1.437 (36.5)	1.875 (47.6)	32
87	44	1	4.125 (104.8)	1.375 (34.9)	2.113 (53.7)	.875 (22.2)	1.250 (31.8)	20
88	44	1	5.125 (130.2)	1.375 (34.9)	2.113 (53.7)	.875 (22.2)	1.250 (31.8)	20
89	44	1	4.125 (104.8)	1.500 (38.1)	2.363 (60.0)	1.000 (25.4)	1.375 (34.9)	24
90	44	1	5.125 (130.2)	1.500 (38.1)	2.363 (60.0)	1.000 (25.4)	1.375 (34.9)	24
91	44	1	4.125 (104.8)	1.781 (45.2)	2.770 (70.4)	1.250 (31.8)	1.625 (41.3)	28
92	44	1	5.125 (130.2)	1.781 (45.2)	2.770 (70.4)	1.250 (31.8)	1.625 (41.3)	28
93	44	1	4.125 (104.8)	1.830 (46.5)	3.020 (76.7)	1.437 (36.5)	1.875 (47.6)	32
94	44	1	5.125 (130.2)	1.830 (46.5)	3.020 (76.7)	1.437 (36.5)	1.875 (47.6)	32
95	48	1	4.125 (104.8)	1.375 (34.9)	2.113 (53.7)	.875 (22.2)	1.250 (31.8)	20
96	48	1	5.125 (130.2)	1.375 (34.9)	2.113 (53.7)	.875 (22.2)	1.250 (31.8)	20
97	48	1	4.125 (104.8)	1.500 (38.1)	2.363 (60.0)	1.000 (25.4)	1.375 (34.9)	24
98	48	1	5.125 (130.2)	1.500 (38.1)	2.363 (60.0)	1.000 (25.4)	1.375 (34.9)	24
99	48	1	4.125 (104.8)	1.781 (45.2)	2.770 (70.4)	1.250 (31.8)	1.625 (41.3)	28
100	48	1	5.125 (130.2)	1.781 (45.2)	2.770 (70.4)	1.250 (31.8)	1.625 (41.3)	28
101	48	1	4.125 (104.8)	1.830 (46.5)	3.020 (76.7)	1.437 (36.5)	1.875 (47.6)	32
102	48	1	5.125 (130.2)	1.830 (46.5)	3.020 (76.7)	1.437 (36.5)	1.875 (47.6)	32
103	61	1	3.125 (79.4)	1.059 (26.9)	1.551 (39.4)	.500 (12.7)	.750 (19.1)	12
104	61	1	4.125 (104.8)	1.059 (26.9)	1.551 (39.4)	.500 (12.7)	.750 (19.1)	12

Continued on Page B-34

Dimensions in inches (millimeters) and are subject to change without notice.



AS85049/11 and MS3437B Straight Environmental Backshell

TABLE II: Dash Number and Cable Range (Continued From Page B-33)

Dash No.	Shell Size	Style	E Max	K Ref.	L Max	Cable Range		M85049/42 Ref.
						Min	Max	
105	61	1	3.125 (79.4)	1.156 (29.4)	1.770 (45.0)	.625 (15.9)	.937 (23.8)	16
106	61	1	4.125 (104.8)	1.156 (29.4)	1.770 (45.0)	.625 (15.9)	.937 (23.8)	16
107	61	2	3.875 (98.4)	1.375 (34.9)	2.113 (53.7)	.875 (22.2)	1.250 (31.8)	20
108	61	2	4.875 (123.8)	1.375 (34.9)	2.113 (53.7)	.875 (22.2)	1.250 (31.8)	20
109	61	2	3.875 (98.4)	1.500 (38.1)	2.363 (60.0)	1.000 (25.4)	1.375 (34.9)	24
110	61	2	4.875 (123.8)	1.500 (38.1)	2.363 (60.0)	1.000 (25.4)	1.375 (34.9)	24
111	12	1	2.125 (54.0)	1.027 (26.1)	1.332 (33.8)	.350 (8.9)	.500 (12.7)	10
112	16	1	2.125 (54.0)	1.027 (26.1)	1.145 (29.1)	.250 (6.4)	.437 (11.1)	6
113	16	1	3.125 (79.4)	1.027 (26.1)	1.145 (29.1)	.250 (6.4)	.437 (11.1)	6
114	12	1	2.125 (54.0)	1.027 (26.1)	.957 (24.3)	.125 (3.2)	.312 (7.9)	4
115	12	1	3.125 (79.4)	1.027 (26.1)	.957 (24.3)	.125 (3.2)	.312 (7.9)	4
116	14	1	2.125 (54.0)	1.027 (26.1)	1.145 (29.1)	.250 (6.4)	.437 (11.1)	6
117	14	1	3.125 (79.4)	1.027 (26.1)	1.145 (29.1)	.250 (6.4)	.437 (11.1)	6
118	16	1	2.125 (54.0)	1.027 (26.1)	1.332 (33.8)	.350 (8.9)	.625 (15.9)	10
119	16	1	3.125 (79.4)	1.027 (26.1)	1.332 (33.8)	.350 (8.9)	.625 (15.9)	10
120	18	1	2.125 (54.0)	1.027 (26.1)	.957 (24.3)	.125 (3.2)	.312 (7.9)	4
121	18	1	3.125 (79.4)	1.027 (26.1)	.957 (24.3)	.125 (3.2)	.312 (7.9)	4
122	18	1	2.125 (54.0)	1.027 (26.1)	1.145 (29.1)	.250 (6.4)	.437 (11.1)	6
123	18	1	3.125 (79.4)	1.027 (26.1)	1.145 (29.1)	.250 (6.4)	.437 (11.1)	6
124	20	1	3.125 (79.4)	1.027 (26.1)	1.145 (29.1)	.250 (6.4)	.437 (11.1)	6
125	20	1	4.125 (104.8)	1.027 (26.1)	1.145 (29.1)	.250 (6.4)	.437 (11.1)	6
126	22	1	3.125 (79.4)	1.027 (26.1)	.957 (24.3)	.125 (3.2)	.312 (7.9)	4
127	22	1	4.125 (104.8)	1.027 (26.1)	.957 (24.3)	.125 (3.2)	.312 (7.9)	4
128	22	1	3.125 (79.4)	1.027 (26.1)	1.145 (29.1)	.250 (6.4)	.437 (11.1)	6
129	22	1	4.125 (104.8)	1.027 (26.1)	1.145 (29.1)	.250 (6.4)	.437 (11.1)	6
130	24	1	3.125 (79.4)	1.027 (26.1)	1.332 (33.8)	.350 (8.9)	.625 (15.9)	10
131	24	1	4.125 (104.8)	1.027 (26.1)	1.332 (33.8)	.350 (8.9)	.625 (15.9)	10
132	36	1	4.125 (104.8)	1.059 (26.9)	1.551 (39.4)	.500 (12.7)	.750 (19.1)	12
133	36	1	5.125 (130.2)	1.059 (26.9)	1.551 (39.4)	.500 (12.7)	.750 (19.1)	12
134	40	1	4.125 (104.8)	1.059 (26.9)	1.551 (39.4)	.500 (12.7)	.750 (19.1)	12
135	40	1	5.125 (130.2)	1.059 (26.9)	1.551 (39.4)	.500 (12.7)	.750 (19.1)	12
136	10	1	2.125 (54.0)	1.027 (26.1)	1.145 (29.1)	.250 (6.4)	.375 (9.5)	6
137	10	1	3.125 (79.4)	1.027 (26.1)	1.145 (29.1)	.250 (6.4)	.375 (9.5)	6
138	12	1	2.125 (54.0)	1.027 (26.1)	1.332 (33.8)	.350 (8.9)	.500 (12.7)	10
139	12	1	3.125 (79.4)	1.027 (26.1)	1.332 (33.8)	.350 (8.9)	.500 (12.7)	10
140	20	1	3.125 (79.4)	1.156 (29.4)	1.770 (45.0)	.625 (15.9)	.904 (23.0)	16
141	20	1	4.125 (104.8)	1.156 (29.4)	1.770 (45.0)	.625 (15.9)	.904 (23.0)	16
142	22	1	3.125 (79.4)	1.375 (34.9)	2.113 (53.7)	.875 (22.2)	1.029 (26.1)	20
143	22	1	4.125 (104.8)	1.375 (34.9)	2.113 (53.7)	.875 (22.2)	1.029 (26.1)	20
144	24	1	3.125 (79.4)	1.375 (34.9)	2.113 (53.7)	.875 (22.2)	1.144 (29.1)	20
145	24	1	4.125 (104.8)	1.375 (34.9)	2.113 (53.7)	.875 (22.2)	1.144 (29.1)	20
146	36	1	4.125 (104.8)	1.830 (46.5)	3.020 (76.7)	1.437 (36.5)	1.840 (46.7)	32
147	36	1	5.125 (130.2)	1.830 (46.5)	3.020 (76.7)	1.437 (36.5)	1.840 (46.7)	32
148	38	1	4.125 (104.8)	1.156 (29.4)	1.770 (45.0)	.625 (15.9)	.937 (23.8)	16
149	38	1	5.125 (130.2)	1.156 (29.4)	1.770 (45.0)	.625 (15.9)	.937 (23.8)	16
150	14	1	2.125 (54.0)	1.027 (26.1)	.957 (24.3)	.125 (3.2)	.312 (7.9)	4
151	14	1	3.125 (79.4)	1.027 (26.1)	.957 (24.3)	.125 (3.2)	.312 (7.9)	4
152	16	1	2.125 (54.0)	1.027 (26.1)	.957 (24.3)	.125 (3.2)	.312 (7.9)	4
153	16	1	3.125 (79.4)	1.027 (26.1)	.957 (24.3)	.125 (3.2)	.312 (7.9)	4
154	44	1	4.125 (104.8)	1.156 (29.4)	1.770 (45.0)	.625 (15.9)	.937 (23.8)	16
155	44	1	5.125 (130.2)	1.156 (29.4)	1.770 (45.0)	.625 (15.9)	.937 (23.8)	16
156	40	1	4.125 (104.8)	1.156 (29.4)	1.770 (45.0)	.625 (15.9)	.937 (23.8)	16
157	40	1	5.125 (130.2)	1.156 (29.4)	1.770 (45.0)	.625 (15.9)	.937 (23.8)	16

Dimensions in inches (millimeters) and are subject to change without notice.

AS85049/14S Self-Locking E-Nut



AS85049

B

CONNECTOR DESIGNATOR:	
H	MIL-DTL-38999 Series III & IV EN36455

Finish
<i>A</i> = Anodize, Black
<i>N</i> = Electroless Nickel
<i>W</i> = 1,000 Hour Cadmium Olive Drab over Electroless Nickel
<i>X</i> = Nickel Fluorocarbon Polymer
<i>Y</i> = Pure Dense Electrodeposited Aluminum
<i>Z</i> = Zinc-Nickel, Black

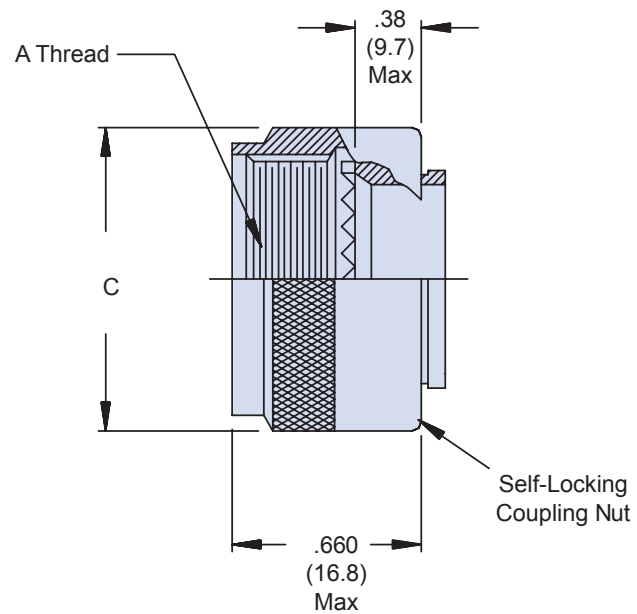
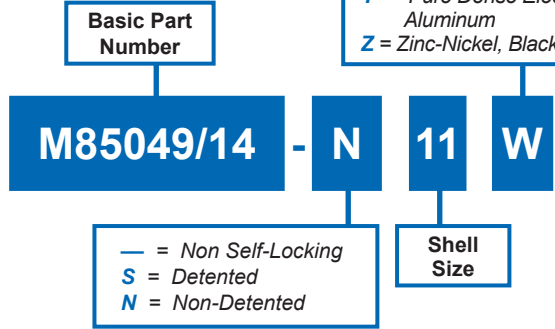

Shell Size	Shell Size Code Ref.	A Thread Class 2B	Ø C Max	
9	A	M12 X 1 - 6H	.86	(21.8)
11	B	M15 X 1 - 6H	.98	(24.9)
13	C	M18 X 1 - 6H	1.16	(29.5)
15	D	1M22 X 1 - 6H	1.28	(32.5)
17	E	M25 X 1 - 6H	1.41	(35.8)
19	F	M28 X 1 - 6H	1.52	(38.6)
21	G	M31 X 1 - 6H	1.64	(41.7)
23	H	M34 X 1 - 6H	1.77	(45.0)
25	J	M37 X 1 - 6H	1.89	(48.0)

- APPLICATION NOTES**
- For complete dimensions, see the applicable Military Specification.
 - Metric dimensions (mm) are indicated in parentheses.

Dimensions in inches (millimeters) and are subject to change without notice.

CONNECTOR DESIGNATOR:

H MIL-DTL-38999, Series III and IV
EN3645

SELF-LOCKING COUPLING

Configuration

— = Non-Self-Locking
N = Non-Detented
G = Self-Locking with Ground Lug
H = Non-Detented with Ground Lug
S = Self-Locking without Ground Lug

Finish

A = Anodize, Black
N = Electroless Nickel
W = 1,000 Hour Cadmium Olive Drab
 over Electroless Nickel
X = Nickel Fluorocarbon Polymer
Y = Pure Dense Electrodeposited
 Aluminum
Z = Zinc-Nickel, Black

Basic Part Number

M85049/15 = 45°
M85049/16 = 90°

M85049/15

G

11

N

Shell Size

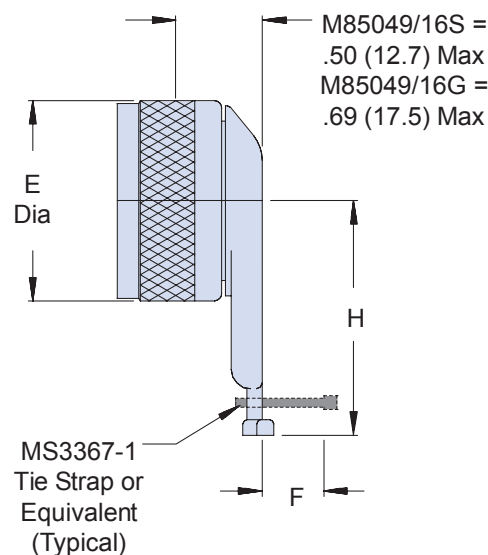
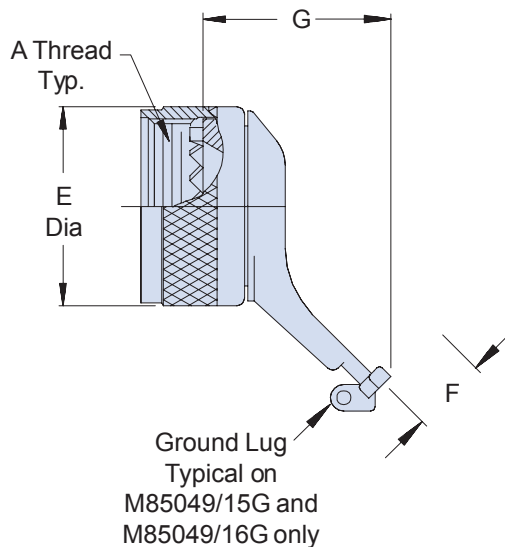

TABLE I: Shell Size, Thread, Cable Entry and Backshell Dimensions

Shell Size	A Thread Class 2B	E Dia Max	F Max Cable Entry	M85049/15S G Max	M85049/15G G Max	M85049/16 H Max
9	M12 X 1 - 6H	.860 (21.8)	.264 (6.7)	1.030 (26.2)	1.210 (30.7)	1.220 (31.0)
11	M15 X 1 - 6H	.984 (25.0)	.392 (10.0)	1.030 (26.2)	1.210 (30.7)	1.290 (32.8)
13	M18 X 1 - 6H	1.160 (29.5)	.506 (12.9)	1.030 (26.2)	1.390 (35.3)	1.620 (41.1)
15	M22 X 1 - 6H	1.280 (32.5)	.631 (16.0)	1.090 (27.7)	1.390 (35.3)	1.660 (42.2)
17	M25 X 1 - 6H	1.410 (35.8)	.756 (19.2)	1.110 (28.2)	1.390 (35.3)	1.720 (43.7)
19	M28 X 1 - 6H	1.520 (38.6)	.845 (21.5)	1.210 (30.7)	1.390 (35.3)	1.720 (43.7)
21	M31 X 1 - 6H	1.640 (41.7)	.970 (24.6)	1.260 (32.0)	1.390 (35.3)	1.790 (45.5)
23	M34 X 1 - 6H	1.770 (45.0)	1.095 (27.8)	1.300 (33.0)	1.390 (35.3)	1.850 (47.0)
25	M37 X 1 - 6H	1.890 (48.0)	1.220 (31.0)	1.340 (34.0)	1.390 (35.3)	1.910 (48.5)

APPLICATION NOTES

1. Assembly identified with manufacturer's name and part number, space permitting.
2. For complete dimensions, see the applicable Military Specification.
3. Cable entry is defined as the accommodation range for the wire bundle or cable. Dimensions shown are not intended for inspection criteria.
4. Metric dimensions (mm) are in parentheses.

Dimensions in inches (millimeters) and are subject to change without notice.

AS85049/17 Straight EMI/RFI Environmental Backshell



AS85049

CONNECTOR DESIGNATOR:

F MIL-DTL-38999 Series I and II

Finish
N = Electroless Nickel **X** = Aluminum, Nickel Fluorocarbon Polymer
W = 1,000 Hr. Cadmium Olive Drab over Electroless Nickel **Z** = Aluminum, Zinc-Nickel, Black over Electroless Nickel

M85049/17

10

N

03

A

Basic Part Number

Dash Number (Table I)

Clamp Size (Table III)

**Length Code (Table IV)
Omit for Standard**

B

TABLE I: Shell Size, Thread and Dimensions

Dash No.	Shell Size Series I	Shell Size Series II	A Thread Class 2B	B Dia Max
08	09	08	.438 - 28 UNEF	.570 (14.5)
10	11	10	.562 - 24 UNEF	.700 (17.8)
12	13	12	.688 - 24 UNEF	.830 (21.1)
14	15	14	.813 - 20 UNEF	.950 (24.1)
16	17	16	.938 - 20 UNEF	1.080 (27.4)
18	19	18	1.063 - 18 UNEF	1.200 (30.5)
20	21	20	1.188 - 18 UNEF	1.330 (33.8)
22	23	22	1.313 - 18 UNEF	1.450 (36.8)
24	25	24	1.438 - 18 UNEF	1.580 (40.1)

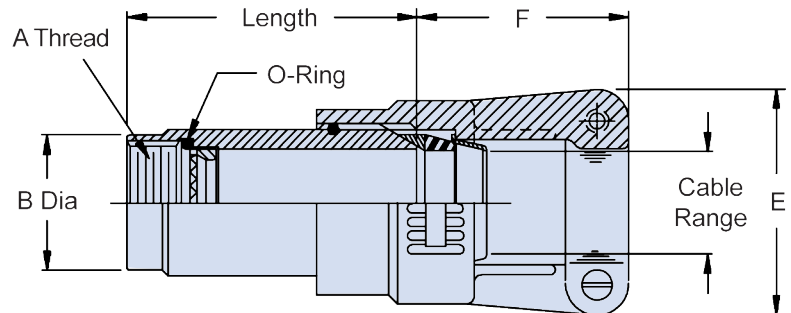

TABLE II: Shell Size and Clamp Size

Dash No.	Shell Size Series I	Shell Size Series II	Clamp Size	
			Min	Max
08	09	08	01	02
10	11	10	01	03
12	13	12	02	04
14	15	14	02	05
16	17	16	02	06
18	19	18	03	07
20	21	20	03	08
22	23	22	03	09
24	25	24	04	10

TABLE III: Clamp Size, Cable Range and Dimensions

Clamp Size	Cable Range		E Max	F Max
	Min	Max		
01	.062 (1.6)	.125 (3.2)	.781 (19.8)	1.250 (31.8)
02	.125 (3.2)	.250 (6.4)	.969 (24.6)	1.250 (31.8)
03	.250 (6.4)	.375 (9.5)	1.062 (27.0)	1.250 (31.8)
04	.375 (9.5)	.500 (12.7)	1.156 (29.4)	1.250 (31.8)
05	.500 (12.7)	.625 (15.9)	1.250 (31.8)	1.312 (33.3)
06	.625 (15.9)	.750 (19.1)	1.375 (34.9)	1.375 (34.9)
07	.750 (19.1)	.875 (22.2)	1.500 (38.1)	1.500 (38.1)
08	.875 (22.2)	1.000 (25.4)	1.625 (41.3)	1.625 (41.3)
09	1.000 (25.4)	1.125 (28.6)	1.750 (44.5)	1.625 (41.3)
10	1.125 (28.6)	1.250 (31.8)	1.875 (47.6)	1.625 (41.3)

TABLE IV: Length Code

Length Code	Available Shell Sizes	Length
Standard	08 - 24	1.500 (38.1)
A	08 - 24	2.500 (63.5)
B	14 - 24	3.500 (88.9)
C	20 - 24	4.500 (114.3)

APPLICATION NOTES

- For complete dimensions see the applicable Military Specification.
- Metric dimensions (mm) are in parentheses.
- Cable Range is defined as the accommodation range for the wire bundle or cable. Dimensions shown are not intended for inspection criteria.

Dimensions in inches (millimeters) and are subject to change without notice.



AS85049/18 Straight EMI/RFI Environmental Backshell

CONNECTOR DESIGNATOR:

H MIL-DTL-38999, Series III and IV
EN3645

Finish
N = Electroless Nickel **X** = Aluminum, Nickel Fluorocarbon Polymer
W = 1,000 Hr. Cadmium Olive Drab over Electroless Nickel **Z** = Aluminum, Zinc-Nickel, Black over Electroless Nickel

M85049/18

11

N

03

A

**Basic
Part Number**

**Shell Size
(Table I)**

**Clamp Size
(Table III)**

**Length Code
(Table IV)
Omit for Standard**

**TABLE I: Shell Size,
Thread and Dimensions**

Shell Size	A Thread Class 2B	B Dia Max
9	M12 X 1 - 6H	.750 (19.1)
11	M15 X 1 - 6H	.850 (21.6)
13	M18 X 1 - 6H	1.000 (25.4)
15	M22 X 1 - 6H	1.150 (29.2)
17	M25 X 1 - 6H	1.250 (31.8)
19	M28 X 1 - 6H	1.400 (35.6)
21	M31 X 1 - 6H	1.550 (39.4)
23	M34 X 1 - 6H	1.650 (41.9)
25	M37 X 1 - 6H	1.850 (47.0)

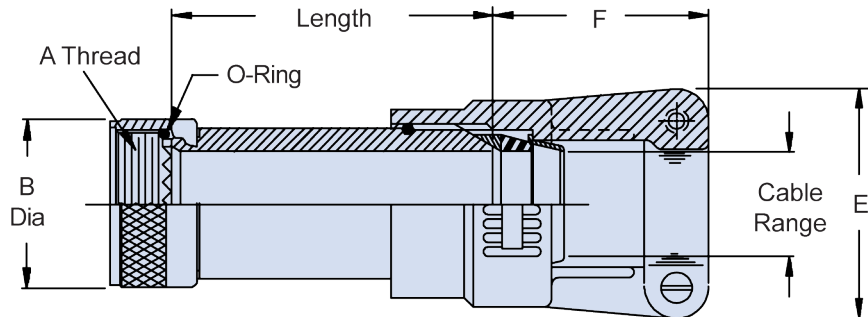

**TABLE II:
Shell Size and
Clamp Size**

Shell Size	Clamp Size	
	Min	Max
9	01	02
11	01	03
13	02	04
15	02	05
17	02	06
19	03	07
21	03	08
23	03	09
25	04	10

TABLE III: Clamp Size, Cable Range and Dimensions

Clamp Size	Cable Range		E Max	F Max
	Min	Max		
01	.062 (1.6)	.125 (3.2)	.781 (19.8)	1.250 (31.8)
02	.125 (3.2)	.250 (6.4)	.969 (24.6)	1.250 (31.8)
03	.250 (6.4)	.375 (9.5)	1.062 (27.0)	1.250 (31.8)
04	.375 (9.5)	.500 (12.7)	1.156 (29.4)	1.250 (31.8)
05	.500 (12.7)	.625 (15.9)	1.250 (31.8)	1.312 (33.3)
06	.625 (15.9)	.750 (19.1)	1.375 (34.9)	1.375 (34.9)
07	.750 (19.1)	.875 (22.2)	1.500 (38.1)	1.500 (38.1)
08	.875 (22.2)	1.000 (25.4)	1.625 (41.3)	1.625 (41.3)
09	1.000 (25.4)	1.125 (28.6)	1.750 (44.5)	1.625 (41.3)
10	1.125 (28.6)	1.250 (31.8)	1.875 (47.6)	1.625 (41.3)

TABLE IV: Length Code

Length Code	Available Shell Sizes	Length
Standard	9 - 25	1.500 (38.1)
A	9 - 25	2.500 (63.5)
B	9 - 25	3.500 (88.9)
C	9 - 25	4.500 (114.3)

APPLICATION NOTES

- For complete dimensions see the applicable Military Specification.
- Metric dimensions (mm) are in parentheses.
- Cable Range is defined as the accommodation range for the wire bundle or cable. Dimensions shown are not intended for inspection criteria.

Dimensions in inches (millimeters) and are subject to change without notice.

AS85049/19 Straight EMI/RFI Non-Environmental Backshell



AS85049

B

CONNECTOR DESIGNATOR:

H MIL-DTL-38999 Series III and IV
EN3645

Finish
N = Electroless Nickel
W = Cadmium, Olive Drab
X = Nickel Fluorocarbon Polymer
Z = Zinc Nickel

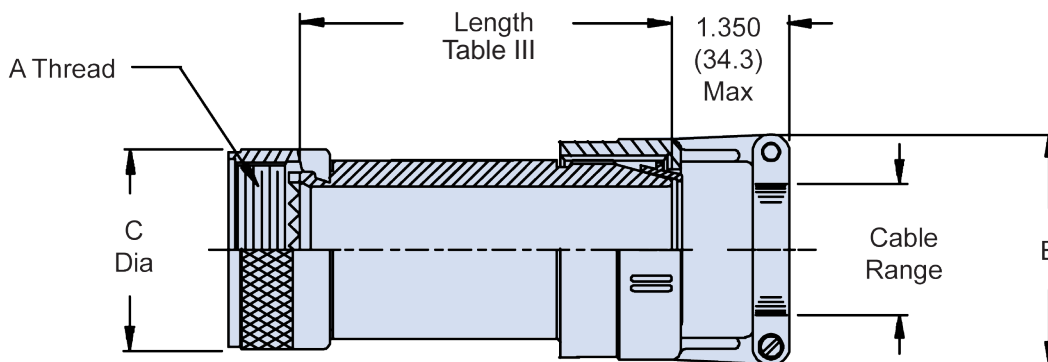
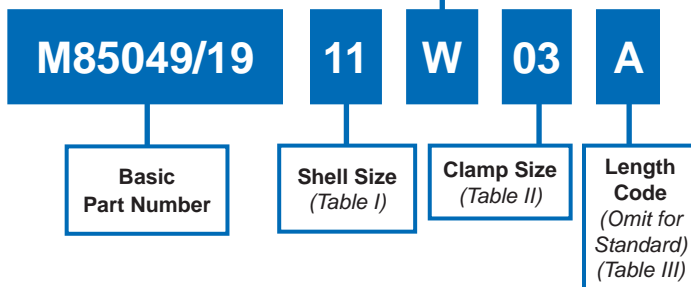

APPLICATION NOTES

1. For complete dimensions see the applicable Military Specification.
2. Metric dimensions (mm) are in parentheses.
3. Cable Range is defined as the accommodation range for the wire bundle or cable. Dimensions shown are not intended for inspection criteria.

Dimensions in inches (millimeters) and are subject to change without notice.



AS85049/19 Straight EMI/RFI Non-Environmental Backshell

TABLE I: Shell Size and Clamp Size

Shell Size	Clamp Size		A Thread Class 6H	C Dia Max
	Min	Max		
9	01	02	M12 X 1 - 6H	.750 (19.1)
11	01	03	M15 X 1 - 6H	.850 (21.6)
13	02	04	M18 X 1 - 6H	1.000 (25.4)
15	02	05	M22 X 1 - 6H	1.100 (27.9)
17	02	06	M25 X 1 - 6H	1.250 (31.8)
19	03	07	M28 X 1 - 6H	1.400 (35.6)
21	03	08	M31 X 1 - 6H	1.500 (38.1)
23	03	09	M34 X 1 - 6H	1.650 (41.9)
25	04	10	M37 X 1 - 6H	1.700 (43.2)

TABLE II: Cable Range and Dimensions

Clamp Size	Cable Range		E Max
	Min	Max	
01	.062 (1.6)	.125 (3.2)	.800 (20.3)
02	.125 (3.2)	.250 (6.4)	1.000 (25.4)
03	.250 (6.4)	.375 (9.5)	1.100 (27.9)
04	.312 (7.9)	.500 (12.7)	1.200 (30.5)
05	.437 (11.1)	.625 (15.9)	1.250 (31.8)
06	.562 (14.3)	.750 (19.1)	1.400 (35.6)
07	.687 (17.4)	.875 (22.2)	1.500 (38.1)
08	.812 (20.6)	1.000 (25.4)	1.650 (41.9)
09	.937 (23.8)	1.125 (28.6)	1.750 (44.5)
10	1.062 (27.0)	1.250 (31.8)	1.900 (48.3)

TABLE III: Length Code

Length Code	Available Shell Sizes	Length
Std.	9 - 25	1.500 (38.1)
A	9 - 25	2.500 (63.5)
B	15 - 25	3.500 (88.9)
C	21 - 25	4.500 (114.3)

Dimensions in inches (millimeters) and are subject to change without notice.

AS85049/20 Straight Crimp Ring Backshell and Crimp Ring



AS85049

B

CONNECTOR DESIGNATOR:	
H	MIL-DTL-38999 Series III and IV EN3645

Finish
<i>N</i> = Electroless Nickel
<i>W</i> = 1,000 Hr. Cadmium Olive Drab over Electroless Nickel
<i>X</i> = Aluminum, Nickel Fluorocarbon Polymer
<i>Z</i> = Aluminum, Zinc-Nickel, Black

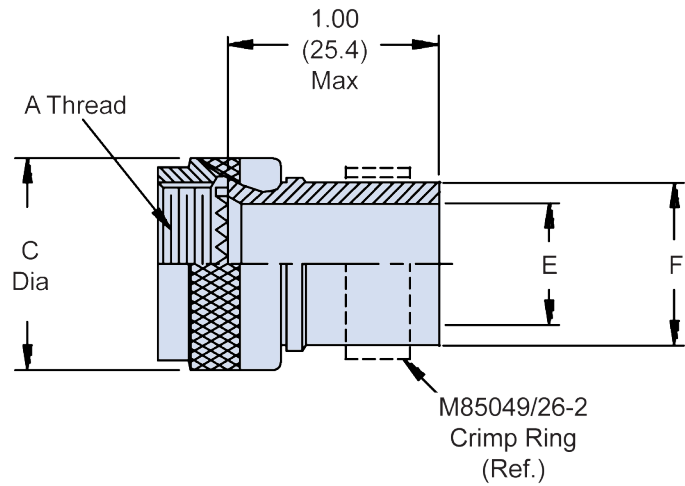
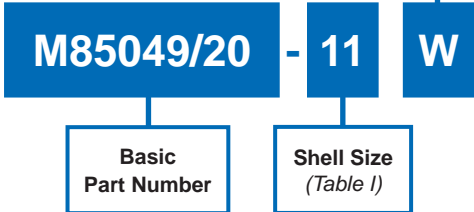

Shell Size	A Thread Class 2B	C Dia Max	E Dia ± .015 (0.4)	F Dia Max	M85049/26-2 Crimp Ring Ref
9	M12 X 1 - 6H	.750 (19.1)	.250 (6.4)	.347 (8.8)	8
11	M15 X 1 - 6H	.850 (21.6)	.325 (8.3)	.498 (12.6)	10
13	M18 X 1 - 6H	1.000 (25.4)	.420 (10.7)	.510 (13.0)	12
15	M22 X 1 - 6H	1.100 (27.9)	.540 (13.7)	.630 (16.0)	14
17	M25 X 1 - 6H	1.250 (31.8)	.670 (17.0)	.760 (19.3)	16
19	M28 X 1 - 6H	1.400 (35.6)	.789 (20.0)	.890 (22.6)	18
21	M31 X 1 - 6H	1.500 (38.1)	.914 (23.2)	1.010 (25.7)	20
23	M34 X 1 - 6H	1.650 (41.9)	1.039 (26.4)	1.130 (28.7)	22
25	M37 X 1 - 6H	1.750 (44.5)	1.112 (28.2)	1.202 (30.5)	24

1.	For complete dimensions see the applicable Military Specification.
2.	Metric dimensions (mm) are in parentheses.
3.	Cable Entry is defined as the accommodation range for the wire bundle or cable. Dimensions shown are not intended for inspection criteria.

Dimensions in inches (millimeters) and are subject to change without notice.

CONNECTOR DESIGNATOR:

H MIL-DTL-38999 Series III and IV
EN3645

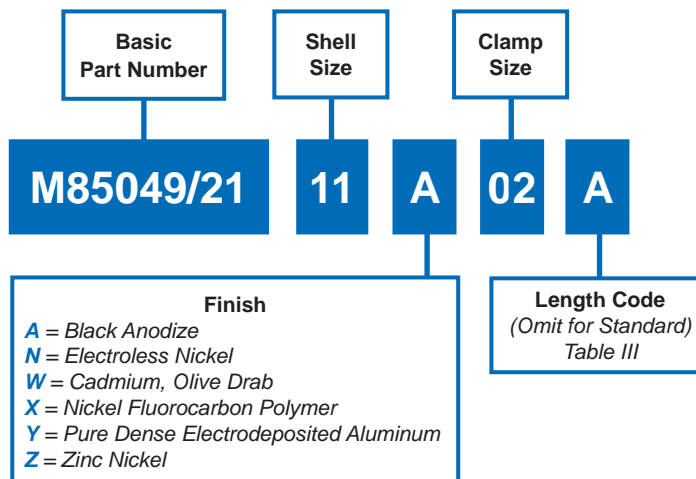

TABLE III: Length Code

Code	Length ± .032 (0.8)
Standard	1.50 (38.1)
A	2.50 (63.5)
B	3.50 (88.9)
C	4.50 (114.3)

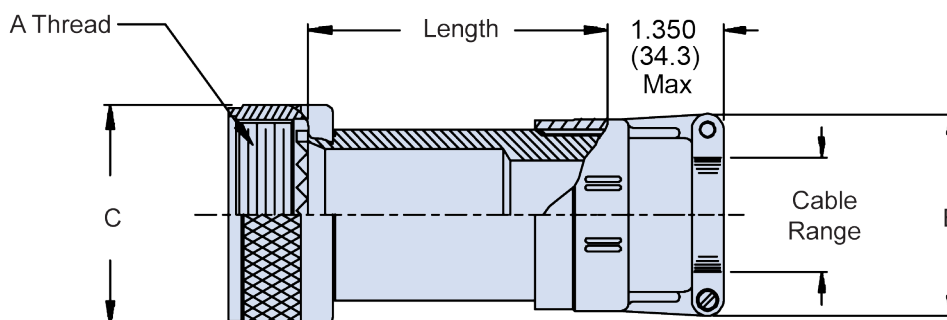

TABLE I: Shell Size, Clamp Size and Dimensions

Shell Size	Clamp Size*		A Thread Class 6H	C Dia Max
	Min	Max		
9	01	02	M12 X 1 - 6H	.750 (19.1)
11	01	03	M15 X 1 - 6H	.850 (21.6)
13	02	04	M18 X 1 - 6H	1.000 (25.4)
15	02	05	M22 X 1 - 6H	1.100 (27.9)
17	02	06	M25 X 1 - 6H	1.250 (31.8)
19	03	07	M28 X 1 - 6H	1.400 (35.6)
21	03	08	M31 X 1 - 6H	1.500 (38.1)
23	03	09	M34 X 1 - 6H	1.650 (41.9)
25	04	10	M37 X 1 - 6H	1.750 (44.5)

*Clamp Size from Table IV, AS85049/21 Specifications.

TABLE II: Clamp Size, Cable Range and Dimensions

Clamp Size	Cable Range		E Max
	Min	Max	
01	.062 (1.6)	.125 (3.2)	.800 (20.3)
02	.125 (3.2)	.250 (6.4)	1.000 (25.4)
03	.250 (6.4)	.375 (9.5)	1.100 (27.9)
04	.312 (7.9)	.500 (12.7)	1.200 (30.5)
05	.437 (11.1)	.625 (15.9)	1.250 (31.8)
06	.562 (14.3)	.750 (19.1)	1.400 (35.6)
07	.687 (17.4)	.875 (22.2)	1.500 (38.1)
08	.812 (20.6)	1.000 (25.4)	1.650 (41.9)
09	.937 (23.8)	1.125 (28.6)	1.750 (44.5)
10	1.062 (27.0)	1.250 (31.8)	1.900 (48.3)

APPLICATION NOTES

- For complete dimensions see the applicable Military Specification.
- Metric dimensions (mm) are in parentheses.
- Cable Range is defined as the accommodation range for the wire bundle or cable. Dimensions shown are not intended for inspection criteria.

Dimensions in inches (millimeters) and are subject to change without notice.

AS85049/23 and MS3189C 45° EMI/RFI Non-Environmental Backshell



AS85049

B

CONNECTOR DESIGNATOR:	
A	AS50151 Series AS34001
	MIL-DTL-26482 Series II
	AS81703 Series III
	MIL-DTL-83723 Series I & III
	40M39569, DEF 5326-3, EN 2997
	EN 3646, ESC 10, ESC 11, LN 29504
	NFC93422 Series HE302 PAN 6432-1, PAN 6432-2, PATT 602

Basic Part Number Dash Number
(Table II)

M85049/23 - 21 N

Superseded Part Number

MS3189C 21 N

Basic Part No. Dash No.

Finish
(Material is Aluminum Only)

A = Cadmium Olive Drab over Nickel
C = Cadmium Olive Drab
N = Electroless Nickel

Finish / Material

B = Black Cadmium / Stainless Steel
N = Electroless Nickel / Aluminum
S = Passivated / Stainless Steel
W = 1,000 Hr. Cadmium Olive Drab over Electroless Nickel / Aluminum
X = Aluminum, Nickel Fluorocarbon Polymer
Z = Aluminum, Zinc-Nickel, Black
XS = Stainless Steel, Nickel Fluorocarbon Polymer
ZS = Stainless Steel, Zinc-Nickel, Black

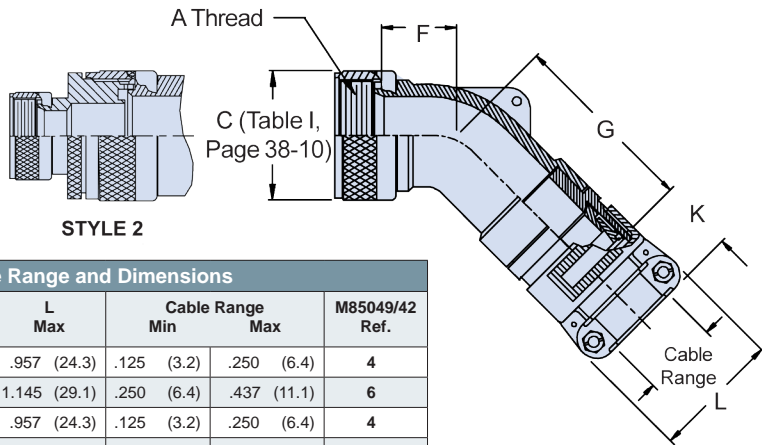

STYLE 2

TABLE II: Dash Number, Cable Range and Dimensions								
Dash No.	Shell Size	F Max	G Max	K Ref.	L Max	Cable Range		M85049/42 Ref.
						Min	Max	
1	3	.687 (17.4)	1.915 (48.6)	1.027 (26.1)	.957 (24.3)	.125 (3.2)	.250 (6.4)	4
2	3	1.500 (38.1)	2.035 (51.7)	1.027 (26.1)	1.145 (29.1)	.250 (6.4)	.437 (11.1)	6
3	8	.625 (15.9)	1.307 (33.2)	1.027 (26.1)	.957 (24.3)	.125 (3.2)	.250 (6.4)	4
4	10	.687 (17.4)	1.975 (50.2)	1.027 (26.1)	.957 (24.3)	.125 (3.2)	.312 (7.9)	4
5	10	.687 (17.4)	1.370 (34.8)	1.027 (26.1)	1.145 (29.1)	.250 (6.4)	.375 (9.5)	6
6	12	.750 (19.1)	2.035 (51.7)	1.027 (26.1)	.957 (24.3)	.125 (3.2)	.312 (7.9)	4
7	12	.750 (19.1)	2.035 (51.7)	1.027 (26.1)	1.145 (29.1)	.250 (6.4)	.437 (11.1)	6
8	12	.750 (19.1)	2.035 (51.7)	1.027 (26.1)	1.332 (33.8)	.350 (8.9)	.500 (12.7)	10
9	14	.812 (20.6)	2.125 (54.0)	1.027 (26.1)	1.145 (29.1)	.250 (6.4)	.437 (11.1)	6
10	14	.812 (20.6)	1.780 (45.2)	1.027 (26.1)	1.332 (33.8)	.350 (8.9)	.575 (14.6)	10
11	16	.906 (23.0)	2.235 (56.8)	1.027 (26.1)	1.145 (29.1)	.250 (6.4)	.437 (11.1)	6
12	16	.906 (23.0)	1.875 (47.6)	1.059 (26.9)	1.551 (39.4)	.500 (12.7)	.700 (17.8)	12
13	18	1.093 (27.8)	2.425 (61.6)	1.027 (26.1)	1.332 (33.8)	.350 (8.9)	.625 (15.9)	10
14	18	1.093 (27.8)	2.062 (52.4)	1.156 (29.4)	1.770 (45.0)	.625 (15.9)	.779 (19.8)	16
15	20	1.093 (27.8)	2.425 (61.6)	1.027 (26.1)	1.332 (33.8)	.350 (8.9)	.625 (15.9)	10
16	20	1.093 (27.8)	2.062 (52.4)	1.156 (29.4)	1.770 (45.0)	.625 (15.9)	.904 (23.0)	16
17	22	1.188 (30.2)	2.575 (65.4)	1.059 (26.9)	1.551 (39.4)	.500 (12.7)	.750 (19.1)	12
18	22	1.188 (30.2)	2.218 (56.3)	1.375 (34.9)	2.113 (53.7)	.875 (22.2)	1.029 (26.1)	20
19	24	1.188 (30.2)	2.575 (65.4)	1.069 (27.2)	1.551 (39.4)	.500 (12.7)	.750 (19.1)	12
20	24	1.188 (30.2)	2.218 (56.3)	1.375 (34.9)	2.113 (53.7)	.875 (22.2)	1.144 (29.1)	20
21	28	1.312 (33.3)	2.625 (66.7)	1.156 (33.7)	1.770 (45.0)	.625 (15.9)	.937 (23.8)	16

Continued on Page B-44

Dimensions in inches (millimeters) and are subject to change without notice.

- APPLICATION NOTES**
- For complete dimensions see the applicable Military Specification.
 - When maximum cable entry is exceeded, Style 2 will be supplied.
 - Metric dimensions (mm) are in parentheses.
 - Cable Range is defined as the accommodation range for the wire bundle or cable. Dimensions shown are not intended for inspection criteria.



AS85049/23 and MS3189C 45° EMI/RFI Non-Environmental Backshell

TABLE II: Continued from Page B-43

Dash No.	Shell Size	F Max	G Max	K Ref.	L Max	Cable Range		M85049/42 Ref.
						Min	Max	
22	28	1.312 (33.3)	2.281 (57.9)	1.500 (38.1)	2.363 (60.0)	1.000 (25.4)	1.375 (34.9)	24
23	32	1.375 (34.9)	2.725 (69.2)	1.156 (29.4)	1.770 (45.0)	.625 (15.9)	.937 (23.8)	16
24	32	1.375 (34.9)	2.725 (69.2)	1.375 (34.9)	2.113 (53.7)	.875 (22.2)	1.250 (31.8)	20
25	32	1.375 (34.9)	2.500 (63.5)	1.781 (45.2)	2.770 (70.4)	1.250 (31.8)	1.625 (41.3)	28
26	36	1.406 (35.7)	2.815 (71.5)	1.156 (29.4)	1.770 (45.0)	.625 (15.9)	.937 (23.8)	16
27	36	1.406 (35.7)	2.815 (71.5)	1.500 (38.1)	2.363 (60.0)	1.000 (25.4)	1.375 (34.9)	24
28	36	1.406 (35.7)	2.469 (62.7)	1.830 (46.5)	3.020 (76.7)	1.437 (36.5)	1.840 (46.7)	32
29	40	2.156 (54.8)	2.815 (71.5)	1.156 (29.4)	1.770 (45.0)	.625 (15.9)	.937 (23.8)	16
30	40	2.156 (54.8)	2.815 (71.5)	1.500 (38.1)	2.363 (60.0)	1.000 (25.4)	1.375 (34.9)	24
31	40	2.156 (54.8)	2.469 (62.7)	1.830 (46.5)	3.020 (76.7)	1.437 (36.5)	1.875 (47.6)	32
32	44	2.156 (54.8)	2.815 (71.5)	1.156 (29.4)	1.770 (45.0)	.625 (15.9)	.937 (23.8)	16
33	44	2.156 (54.8)	2.815 (71.5)	1.500 (38.1)	2.363 (60.0)	1.000 (25.4)	1.375 (34.9)	24
34	44	2.156 (54.8)	2.469 (62.7)	1.830 (46.5)	3.020 (76.7)	1.437 (36.5)	1.875 (47.6)	32
35	48	2.156 (54.8)	2.815 (71.5)	1.156 (29.4)	1.770 (45.0)	.625 (15.9)	.937 (23.8)	16
36	48	2.156 (54.8)	2.815 (71.5)	1.500 (38.1)	2.363 (60.0)	1.000 (25.4)	1.375 (34.9)	24
37	48	2.156 (54.8)	2.469 (62.7)	1.830 (46.5)	3.020 (76.7)	1.437 (36.5)	1.875 (47.6)	32
38	61	1.188 (30.2)	2.575 (65.4)	1.059 (26.9)	1.551 (39.4)	.500 (12.7)	.750 (19.1)	12
39	61	1.188 (30.2)	2.218 (56.3)	1.375 (34.9)	2.113 (53.7)	.875 (22.2)	1.184 (30.1)	20
40	16	.906 (23.0)	2.235 (56.8)	1.027 (26.1)	1.332 (33.8)	.350 (8.9)	.625 (15.9)	10
41	18	1.093 (27.8)	2.425 (61.6)	1.027 (26.1)	.957 (24.3)	.125 (3.2)	.312 (7.9)	4
42	18	1.093 (27.8)	2.425 (61.6)	1.027 (26.1)	1.145 (29.1)	.250 (6.4)	.437 (11.1)	6
43	20	1.093 (27.8)	2.425 (61.6)	1.027 (26.1)	1.145 (29.1)	.250 (6.4)	.437 (11.1)	6
44	22	1.188 (30.2)	2.575 (65.4)	1.027 (26.1)	.957 (24.3)	.125 (3.2)	.312 (7.9)	4
45	22	1.188 (30.2)	2.575 (65.4)	1.027 (26.1)	1.145 (29.1)	.250 (6.4)	.437 (11.1)	6
46	24	1.188 (30.2)	2.575 (65.4)	1.027 (26.1)	1.332 (33.8)	.350 (8.9)	.625 (15.9)	10
47	36	1.406 (35.7)	2.815 (71.5)	1.059 (26.9)	1.551 (39.4)	.500 (12.7)	.750 (19.1)	12
48	40	2.156 (54.8)	2.815 (71.5)	1.059 (26.9)	1.551 (39.4)	.500 (12.7)	.750 (19.1)	12
49*	10	1.500 (38.1)	2.035 (51.7)	1.027 (26.1)	1.145 (29.1)	.250 (6.4)	.437 (11.1)	6
50*	14	1.842 (46.8)	2.425 (61.6)	1.059 (26.9)	1.551 (39.4)	.500 (12.7)	.750 (19.1)	12
51*	16	1.938 (49.2)	2.575 (65.4)	1.156 (29.4)	1.770 (45.0)	.625 (15.9)	.937 (23.8)	16
52	18	1.093 (27.8)	2.425 (61.6)	1.059 (26.9)	1.551 (39.4)	.500 (12.7)	.750 (19.1)	12
53	61	1.188 (30.2)	2.575 (65.4)	1.156 (29.4)	1.770 (45.0)	.625 (15.9)	.937 (23.8)	16
54	20	1.093 (27.8)	2.425 (61.6)	1.059 (26.9)	1.551 (39.4)	.500 (12.7)	.750 (19.1)	12
55*	20	2.061 (52.3)	2.625 (66.7)	1.375 (34.9)	2.113 (53.7)	.875 (22.2)	1.250 (31.8)	20
56	22	1.188 (30.2)	2.575 (65.4)	1.027 (26.1)	1.332 (33.8)	.350 (8.9)	.625 (15.9)	10
57	22	1.188 (30.2)	2.575 (65.4)	1.156 (29.4)	1.770 (45.0)	.625 (15.9)	.937 (23.8)	16
58*	22	2.061 (52.3)	2.625 (66.7)	1.375 (34.9)	2.113 (53.7)	.875 (22.2)	1.250 (31.8)	20
59	24	1.188 (30.2)	2.575 (65.4)	1.156 (29.4)	1.770 (45.0)	.625 (15.9)	.937 (23.8)	16
60	28	1.312 (33.3)	2.625 (66.7)	1.059 (26.9)	1.551 (39.4)	.500 (12.7)	.750 (19.1)	12
61	28	1.312 (33.3)	2.625 (66.7)	1.375 (34.9)	2.113 (53.7)	.875 (22.2)	1.250 (31.8)	20
62	32	1.375 (34.9)	2.725 (69.2)	1.500 (38.1)	2.363 (60.0)	1.000 (25.4)	1.375 (34.9)	24
63	36	1.406 (35.7)	2.815 (71.5)	1.375 (34.9)	2.113 (53.7)	.875 (22.2)	1.250 (31.8)	20
64	36	1.406 (35.7)	2.815 (71.5)	1.781 (45.2)	2.770 (70.4)	1.250 (31.8)	1.625 (41.3)	28
65	40	2.156 (54.8)	2.815 (71.5)	1.375 (34.9)	2.113 (53.7)	.875 (22.2)	1.250 (31.8)	20
66	40	2.156 (54.8)	2.815 (71.5)	1.781 (45.2)	2.770 (70.4)	1.250 (31.8)	1.625 (41.3)	28
67	44	2.156 (54.8)	2.815 (71.5)	1.375 (34.9)	2.113 (53.7)	.875 (22.2)	1.250 (31.8)	20
68	44	2.156 (54.8)	2.815 (71.5)	1.781 (45.2)	2.770 (70.4)	1.250 (31.8)	1.625 (41.3)	28
69	48	2.156 (54.8)	2.815 (71.5)	1.375 (34.9)	2.113 (53.7)	.875 (22.2)	1.250 (31.8)	20
70	48	2.156 (54.8)	2.815 (71.5)	1.781 (45.2)	2.770 (70.4)	1.250 (31.8)	1.625 (41.3)	28
71*	12	1.684 (42.8)	2.236 (56.8)	1.027 (26.1)	1.332 (33.8)	.350 (8.9)	.625 (15.9)	10
72*	18	1.938 (49.2)	2.575 (65.4)	1.156 (29.4)	1.770 (45.0)	.625 (15.9)	.937 (23.8)	16
73*	24	2.061 (52.3)	2.625 (66.7)	1.375 (34.9)	2.113 (53.7)	.875 (22.2)	1.250 (31.8)	20
74	14	.812 (20.6)	2.125 (54.0)	1.027 (26.1)	.957 (24.3)	.125 (3.2)	.312 (7.9)	04
75	16	.906 (23.0)	2.235 (56.8)	1.027 (26.1)	.957 (24.3)	.125 (3.2)	.312 (7.9)	04

* Denotes Style 2

Dimensions in inches (millimeters) and are subject to change without notice.

AS85049/24 and MS3188C 90° EMI/RFI Non-Environmental Backshell



AS85049

B

CONNECTOR DESIGNATOR:	
A	AS50151 Series AS34001
	MIL-DTL-26482 Series II
	AS81703 Series III
	MIL-DTL-83723 Series I & III
	40M39569, DEF 5326-3, EN 2997
	EN 3646, ESC 10, ESC 11, LN 29504
	NFC93422 Series HE302
	PAN 6432-1, PAN 6432-2, PATT 602

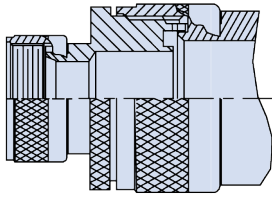

STYLE 2

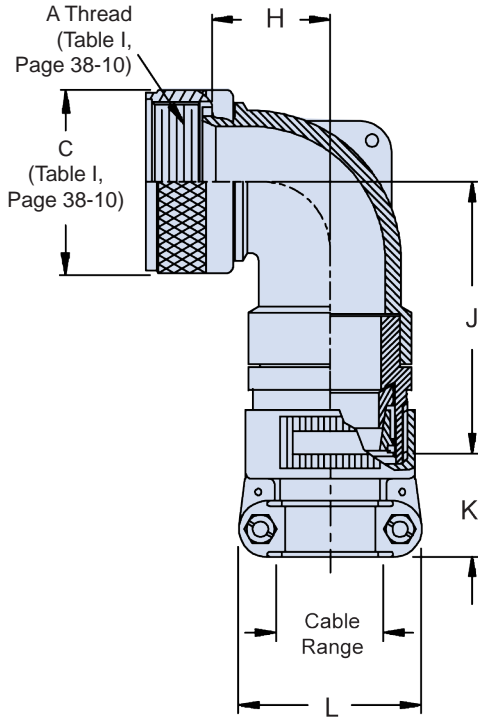

Basic Part Number Dash Number (Table II)

M85049/24 - 21 N

Finish / Material
B = Black Cadmium / Stainless Steel
N = Electroless Nickel / Aluminum
S = Passivated / Stainless Steel
W = 1,000 Hr. Cadmium Olive Drab over Electroless Nickel / Aluminum
X = Aluminum, Nickel Fluorocarbon Polymer
Z = Aluminum, Zinc-Nickel, Black
XS = Stainless Steel, Nickel Fluorocarbon Polymer
ZS = Stainless Steel, Zinc-Nickel, Black

Superseded Part Number

MS3188C 21 N

Basic Part No. Dash No.

Finish (Material is Aluminum Only)
A = Cadmium Olive Drab over Nickel
C = Cadmium Olive Drab
N = Electroless Nickel

Dash No.	Shell Size	H Max	J Max	K Ref.	L Max	Cable Range		M85049/42 Ref.
						Min	Max	
1	03	.698 (17.7)	1.862 (47.3)	1.027 (26.1)	.957 (24.3)	.125 (3.2)	.250 (6.4)	04
2	03	1.448 (36.8)	1.382 (35.1)	1.027 (26.1)	1.145 (29.1)	.250 (6.4)	.437 (11.1)	04
3	08	.603 (15.3)	1.262 (32.1)	1.027 (26.1)	.957 (24.3)	.125 (3.2)	.250 (6.4)	04
4	10	.698 (17.7)	1.982 (50.3)	1.027 (26.1)	.957 (24.3)	.125 (3.2)	.312 (7.9)	04
5	10	.698 (17.7)	1.382 (35.1)	1.027 (26.1)	1.145 (29.1)	.250 (6.4)	.375 (9.5)	06
6	12	.703 (17.9)	2.002 (50.9)	1.027 (26.1)	.957 (24.3)	.125 (3.2)	.312 (7.9)	04
7	12	.703 (17.9)	2.002 (50.9)	1.027 (26.1)	1.145 (29.1)	.250 (6.4)	.437 (11.1)	06
8	12	.703 (17.9)	1.397 (35.5)	1.027 (26.1)	1.332 (33.8)	.350 (8.9)	.500 (12.7)	10
9	14	.803 (20.4)	2.072 (52.6)	1.027 (26.1)	1.145 (29.1)	.250 (6.4)	.437 (11.1)	06
10	14	.803 (20.4)	1.717 (43.6)	1.027 (26.1)	1.332 (33.8)	.350 (8.9)	.575 (14.6)	10
11	16	.988 (25.1)	2.162 (54.9)	1.027 (26.1)	1.145 (29.1)	.250 (6.4)	.437 (11.1)	06
12	16	.988 (25.1)	1.807 (45.9)	1.059 (26.9)	1.551 (39.4)	.500 (12.7)	.700 (17.8)	12
13	18	1.078 (27.4)	2.332 (59.2)	1.027 (26.1)	1.332 (33.8)	.350 (8.9)	.625 (15.9)	10
14	18	1.078 (27.4)	1.982 (50.3)	1.156 (29.4)	1.770 (45.0)	.625 (15.9)	.779 (19.8)	16
15	20	1.078 (27.4)	2.332 (59.2)	1.027 (26.1)	1.332 (33.8)	.350 (8.9)	.625 (15.9)	10
16	20	1.079 (27.4)	1.982 (50.3)	1.156 (29.4)	1.770 (45.0)	.625 (15.9)	.904 (23.0)	16
17	22	1.228 (31.2)	2.442 (62.0)	1.059 (26.9)	1.551 (39.4)	.500 (12.7)	.750 (19.1)	12
18	22	1.228 (31.2)	2.087 (53.0)	1.375 (34.9)	2.113 (53.7)	.875 (22.2)	1.029 (26.1)	20
19	24	1.228 (31.2)	2.442 (62.0)	1.059 (26.9)	1.551 (39.4)	.500 (12.7)	.750 (19.1)	12
20	24	1.228 (31.2)	2.087 (53.0)	1.375 (34.9)	2.113 (53.7)	.875 (22.2)	1.144 (29.1)	20
21	28	1.328 (33.7)	2.612 (66.3)	1.156 (33.7)	1.770 (45.0)	.625 (15.9)	.937 (23.8)	16

Continued on Page B-46 • Refer to the Mil-Spec for Complete Dimensions

Dimensions in inches (millimeters) and are subject to change without notice.

© 2013 Glenair, Inc.

U.S. CAGE Code 06324

Printed in U.S.A.



AS85049/24 and MS3188C 90° EMI/RFI Non-Environmental Backshell

TABLE II: Continued from Page B-45 • Refer to the Mil-DSpec for Complete Dimensions

Dash No.	Shell Size	H Max	K Max	K Ref.	L Max	Cable Range		M85049/42 Ref.
						Min	Max	
22	28	1.328 (33.7)	2.257 (57.3)	1.500 (38.1)	2.363 (60.0)	1.000 (25.4)	1.375 (34.9)	24
23	32	1.678 (42.6)	2.862 (72.7)	1.156 (29.4)	1.770 (45.0)	.625 (15.9)	.937 (23.8)	16
24	32	1.678 (42.6)	2.862 (72.7)	1.375 (34.9)	2.113 (53.7)	.875 (22.2)	1.250 (31.8)	20
25	32	1.678 (42.6)	2.507 (63.7)	1.781 (45.2)	2.770 (70.4)	1.250 (31.8)	1.625 (41.3)	28
26	36	1.878 (47.7)	2.832 (71.9)	1.156 (29.4)	1.770 (45.0)	.625 (15.9)	.937 (23.8)	16
27	36	1.878 (47.7)	2.832 (71.9)	1.500 (38.1)	2.363 (60.0)	1.000 (25.4)	1.375 (34.9)	24
28	36	1.878 (47.7)	2.477 (62.9)	1.830 (46.5)	3.020 (76.7)	1.437 (36.5)	1.840 (46.7)	32
29	40	2.628 (66.8)	2.832 (71.9)	1.156 (29.4)	1.770 (45.0)	.625 (15.9)	.937 (23.8)	16
30	40	2.628 (66.8)	2.832 (71.9)	1.500 (38.1)	2.363 (60.0)	1.000 (25.4)	1.375 (34.9)	24
31	40	2.628 (66.8)	2.477 (62.9)	1.830 (46.5)	3.020 (76.7)	1.437 (36.5)	1.875 (47.6)	32
32	44	2.628 (66.8)	2.832 (71.9)	1.156 (29.4)	1.770 (45.0)	.625 (15.9)	.937 (23.8)	16
33	44	2.628 (66.8)	2.832 (71.9)	1.500 (38.1)	2.363 (60.0)	1.000 (25.4)	1.375 (34.9)	24
34	44	2.628 (66.8)	2.477 (62.9)	1.830 (46.5)	3.020 (76.7)	1.437 (36.5)	1.875 (47.6)	32
35	48	2.628 (66.8)	2.832 (71.9)	1.156 (29.4)	1.770 (45.0)	.625 (15.9)	.937 (23.8)	16
36	48	2.628 (66.8)	2.832 (71.9)	1.500 (38.1)	2.363 (60.0)	1.000 (25.4)	1.375 (34.9)	24
37	48	2.628 (66.8)	2.477 (62.9)	1.830 (46.5)	3.020 (76.7)	1.437 (36.5)	1.875 (47.6)	32
38	61	1.228 (31.2)	2.442 (62.0)	1.059 (26.9)	1.551 (39.4)	.500 (12.7)	.750 (19.1)	12
39	61	1.228 (31.2)	2.087 (53.0)	1.375 (34.9)	2.113 (53.7)	.875 (22.2)	1.184 (30.1)	20
40	16	.988 (25.1)	2.162 (54.9)	1.027 (26.1)	1.332 (33.8)	.350 (8.9)	.625 (15.9)	10
41	18	1.078 (27.4)	2.332 (59.2)	1.027 (26.1)	.957 (24.3)	.125 (3.2)	.312 (7.9)	04
42	18	1.078 (27.4)	2.332 (59.2)	1.027 (26.1)	1.145 (29.1)	.250 (6.4)	.437 (11.1)	06
43	20	1.078 (27.4)	2.332 (59.2)	1.027 (26.1)	1.145 (29.1)	.250 (6.4)	.437 (11.1)	06
44	22	1.228 (31.2)	2.442 (62.0)	1.027 (26.1)	.957 (24.3)	.125 (3.2)	.312 (7.9)	04
45	22	1.228 (31.2)	2.442 (62.0)	1.027 (26.1)	1.145 (29.1)	.250 (6.4)	.437 (11.1)	06
46	24	1.228 (31.2)	2.442 (62.0)	1.027 (26.1)	1.332 (33.8)	.350 (8.9)	.625 (15.9)	10
47	36	1.878 (47.7)	2.832 (71.9)	1.059 (26.9)	1.551 (39.4)	.500 (12.7)	.750 (19.1)	12
48	40	1.878 (47.7)	2.832 (71.9)	1.059 (26.9)	1.551 (39.4)	.500 (12.7)	.750 (19.1)	12
49*	10	1.453 (36.9)	2.002 (50.9)	1.027 (26.1)	1.145 (29.1)	.250 (6.4)	.437 (11.1)	06
50*	14	1.828 (46.4)	2.334 (59.3)	1.059 (26.9)	1.551 (39.4)	.500 (12.7)	.750 (19.1)	12
51*	16	1.978 (50.2)	2.442 (62.0)	1.156 (29.4)	1.770 (45.0)	.625 (15.9)	.937 (23.8)	16
52	18	1.078 (27.4)	2.332 (59.2)	1.059 (26.9)	1.551 (39.4)	.500 (12.7)	.750 (19.1)	12
53	61	1.228 (31.2)	2.087 (53.0)	1.156 (29.4)	1.770 (45.0)	.625 (15.9)	.937 (23.8)	16
54	20	1.078 (27.4)	2.332 (59.2)	1.059 (26.9)	1.551 (39.4)	.500 (12.7)	.750 (19.1)	12
55*	20	2.078 (52.8)	2.612 (66.3)	1.375 (34.9)	2.113 (53.7)	.875 (22.2)	1.250 (31.8)	20
56	22	1.228 (31.2)	2.442 (62.0)	1.027 (26.1)	1.332 (33.8)	.350 (8.9)	.625 (15.9)	10
57	22	1.228 (31.2)	2.442 (62.0)	1.156 (29.4)	1.770 (45.0)	.625 (15.9)	.937 (23.8)	16
58*	22	2.078 (52.8)	2.612 (66.3)	1.375 (34.9)	2.113 (53.7)	.875 (22.2)	1.250 (31.8)	20
59	24	1.228 (31.2)	2.442 (62.0)	1.156 (29.4)	1.770 (45.0)	.625 (15.9)	.937 (23.8)	16
60	28	1.328 (33.7)	2.612 (66.3)	1.059 (26.9)	1.551 (39.4)	.500 (12.7)	.750 (19.1)	12
61	28	1.328 (33.7)	2.612 (66.3)	1.375 (34.9)	2.113 (53.7)	.875 (22.2)	1.250 (31.8)	20
62	32	1.678 (42.6)	2.862 (72.7)	1.500 (38.1)	2.363 (60.0)	1.000 (25.4)	1.375 (34.9)	24
63	36	1.878 (47.7)	2.832 (71.9)	1.375 (34.9)	2.113 (53.7)	.875 (22.2)	1.250 (31.8)	20
64	36	1.878 (47.7)	2.832 (71.9)	1.781 (45.2)	2.770 (70.4)	1.250 (31.8)	1.625 (41.3)	28
65	40	2.628 (66.8)	2.832 (71.9)	1.375 (34.9)	2.113 (53.7)	.875 (22.2)	1.250 (31.8)	20
66	40	2.628 (66.8)	2.832 (71.9)	1.375 (34.9)	2.113 (53.7)	.875 (22.2)	1.250 (31.8)	28
67	44	2.628 (66.8)	2.832 (71.9)	1.375 (34.9)	2.113 (53.7)	.875 (22.2)	1.250 (31.8)	20
68	44	2.628 (66.8)	2.832 (71.9)	1.781 (45.2)	2.770 (70.4)	1.250 (31.8)	1.625 (41.3)	28
69	48	2.628 (66.8)	2.832 (71.9)	1.375 (34.9)	2.113 (53.7)	.875 (22.2)	1.250 (31.8)	20
70	48	2.628 (66.8)	2.832 (71.9)	1.781 (45.2)	2.770 (70.4)	1.250 (31.8)	1.625 (41.3)	28
71*	12	1.748 (44.4)	2.162 (54.9)	1.027 (26.1)	1.332 (33.8)	.350 (8.9)	.625 (15.9)	10
72*	18	1.988 (50.5)	2.442 (62.0)	1.156 (29.4)	1.770 (45.0)	.625 (15.9)	.937 (23.8)	16
73*	24	2.088 (53.0)	2.612 (66.3)	1.375 (34.9)	2.116 (53.7)	.875 (22.2)	1.250 (31.8)	20
74	14	.803 (20.4)	2.072 (52.6)	1.027 (26.1)	.957 (24.3)	.125 (3.2)	.312 (7.9)	04
75	16	.988 (25.1)	2.162 (54.9)	1.027 (26.1)	.957 (24.3)	.125 (3.2)	.312 (7.9)	04

Dimensions in inches (millimeters) and are subject to change without notice.

AS85049/25 and MS3437C Straight EMI/RFI Non-Environmental Backshell



AS85049

CONNECTOR DESIGNATOR:

A

AS50151 Series AS34001
MIL-DTL-26482 Series II
AS81703 Series III
MIL-DTL-83723 Series I & III
40M39569, DEF 5326-3, EN 2997
EN 3646, ESC 10, ESC 11, LN 29504
NFC93422 Series HE302
PAN 6432-1, PAN 6432-2, PATT 602

Basic
Part Number

Dash Number
(Table II)

M85049/25

- 21

N

Superseded
Part Number

MS3188C 21 N

Basic
Part No.

Dash
No.

**Finish
(Material is Aluminum Only)**

A = Cadmium Olive Drab over Nickel
C = Cadmium Olive Drab
N = Electroless Nickel

B

Finish / Material

B = Black Cadmium / Stainless Steel
N = Electroless Nickel / Aluminum
S = Passivated / Stainless Steel
W = 1,000 Hr. Cadmium Olive Drab
over Electroless Nickel / Aluminum
X = Aluminum, Nickel Fluorocarbon Polymer
Z = Aluminum, Zinc-Nickel, Black
XS = Stainless Steel, Nickel Fluorocarbon Polymer
ZS = Stainless Steel, Zinc-Nickel, Black

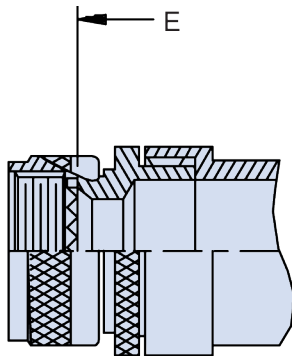

STYLE 2

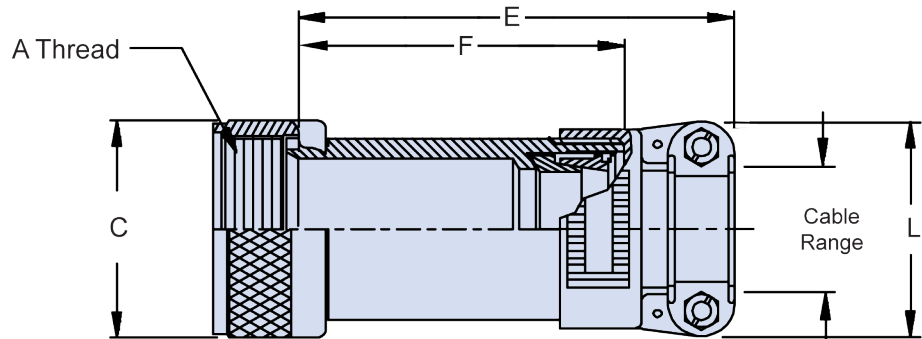

STYLE 1

APPLICATION NOTES

1. For complete dimensions see the applicable Military Specification.
2. When maximum cable entry is exceeded, Style 2 will be supplied.
3. Metric dimensions (mm) are in parentheses.
4. Cable Range is defined as the accommodation range for the wire bundle or cable. Dimensions shown are not intended for inspection criteria.

Dimensions in inches (millimeters) and are subject to change without notice.

© 2013 Glenair, Inc.

U.S. CAGE Code 06324

Printed in U.S.A.



AS85049/25 and MS3437C Straight EMI/RFI Non-Environmental Backshell

TABLE I: Shell Size

Dash No.	A Thread Class 2B	C Dia Ref
03	.562 - 24 UNEF	.77 (19.6)
08	.500 - 20 UNF	.65 (16.5)
10	.625 - 24 UNEF	.77 (19.6)
12	.750 - 20 UNEF	.40 (10.2)
14	.875 - 20 UNEF	1.02 (25.9)
16	1.000 - 20 UNEF	1.21 (30.7)
18	1.062 - 18 UNEF	1.23 (31.2)
20	1.188 - 18 UNEF	1.36 (34.5)
22	1.313 - 18 UNEF	1.48 (37.6)
24	1.438 - 18 UNEF	1.73 (43.9)
28	1.750 - 18 UNS	1.97 (50.0)
32	2.000 - 18 UNS	2.22 (56.4)
36	2.250 - 16 UN	2.47 (62.7)
40	2.500 - 16 UN	2.72 (69.1)
44	2.750 - 16 UN	2.97 (75.4)
48	3.000 - 16 UN	3.22 (81.8)
61	1.500 - 18 UNEF	1.67 (42.4)

Refer to the
Mil-Spec
for
Complete
Dimensions

TABLE II: Dash Number, Dimensions and Cable Range

Dash No.	Shell Size	Style	E Max	F Ref.	L Max	Cable Range		M85049/42 Ref.
						Min	Max	
01	03	1	2.062 (52.4)	1.027 (26.1)	.957 (24.3)	.125 (3.2)	.250 (6.4)	4
02	03	1	3.063 (77.8)	1.027 (26.1)	.957 (24.3)	.125 (3.2)	.250 (6.4)	4
03	03	2	2.812 (71.4)	1.027 (26.1)	1.145 (29.1)	.250 (6.4)	.437 (11.1)	6
04	03	2	3.812 (96.8)	1.027 (26.1)	1.145 (29.1)	.250 (6.4)	.437 (11.1)	6
05	08	1	2.062 (52.4)	1.027 (26.1)	.957 (24.3)	.125 (3.2)	.250 (6.4)	4
06	08	1	3.062 (77.8)	1.027 (26.1)	.957 (24.3)	.125 (3.2)	.250 (6.4)	4
07	08	2	2.812 (71.4)	1.027 (26.1)	1.145 (29.1)	.250 (6.4)	.437 (11.1)	6
08	08	2	3.812 (96.8)	1.027 (26.1)	1.145 (29.1)	.250 (6.4)	.437 (11.1)	6
09	10	1	2.062 (52.4)	1.027 (26.1)	.957 (24.3)	.125 (3.2)	.312 (7.9)	4
10	10	1	3.062 (77.8)	1.027 (26.1)	.957 (24.3)	.125 (3.2)	.312 (7.9)	4
11	10	2	2.812 (71.4)	1.027 (26.1)	1.145 (29.1)	.250 (6.4)	.437 (11.1)	6
12	10	2	3.812 (96.8)	1.027 (26.1)	1.145 (29.1)	.250 (6.4)	.437 (11.1)	6
13	12	1	2.062 (52.4)	1.027 (26.1)	1.145 (29.1)	.250 (6.4)	.437 (11.1)	6
14	12	1	3.062 (77.8)	1.027 (26.1)	1.145 (29.1)	.250 (6.4)	.437 (11.1)	6
15	12	2	2.812 (71.4)	1.027 (26.1)	1.332 (33.8)	.350 (8.9)	.625 (15.9)	10
16	12	2	3.812 (96.8)	1.027 (26.1)	1.332 (33.8)	.350 (8.9)	.625 (15.9)	10
17	14	1	2.062 (52.4)	1.027 (26.1)	1.332 (33.8)	.350 (8.9)	.575 (14.6)	10
18	14	1	3.062 (77.8)	1.027 (26.1)	1.332 (33.8)	.350 (8.9)	.575 (14.6)	10
19	14	2	2.812 (71.4)	1.059 (26.9)	1.551 (39.4)	.500 (12.7)	.750 (19.1)	12
20	14	2	3.812 (96.8)	1.059 (26.9)	1.551 (39.4)	.500 (12.7)	.750 (19.1)	12
21	16	1	2.062 (52.4)	1.059 (26.9)	1.551 (39.4)	.500 (12.7)	.700 (17.8)	12
22	16	1	3.062 (77.8)	1.059 (26.9)	1.551 (39.4)	.500 (12.7)	.700 (17.8)	12
23	16	2	2.812 (71.4)	1.156 (29.4)	1.770 (45.0)	.625 (15.9)	.937 (23.8)	16
24	16	2	3.812 (96.8)	1.156 (29.4)	1.770 (45.0)	.625 (15.9)	.937 (23.8)	16
25	18	1	2.062 (52.4)	1.027 (26.1)	1.332 (33.8)	.350 (8.9)	.625 (15.9)	10
26	18	1	3.062 (77.8)	1.027 (26.1)	1.332 (33.8)	.350 (8.9)	.625 (15.9)	10
27	18	1	2.062 (52.4)	1.059 (26.9)	1.551 (39.4)	.500 (12.7)	.750 (19.1)	12
28	18	1	3.062 (77.8)	1.059 (26.9)	1.551 (39.4)	.500 (12.7)	.750 (19.1)	12
29	18	2	2.812 (71.4)	1.156 (29.4)	1.770 (45.0)	.625 (15.9)	.937 (23.8)	16
30	18	2	3.812 (96.8)	1.156 (29.4)	1.770 (45.0)	.625 (15.9)	.937 (23.8)	16
31	20	1	3.062 (77.8)	1.027 (26.1)	1.332 (33.8)	.350 (8.9)	.625 (15.9)	10
32	20	1	4.062 (103.2)	1.027 (26.1)	1.332 (33.8)	.350 (8.9)	.625 (15.9)	10
33	20	1	3.062 (77.8)	1.059 (26.9)	1.551 (39.4)	.500 (12.7)	.750 (19.1)	12
34	20	1	4.062 (103.2)	1.059 (26.9)	1.551 (39.4)	.500 (12.7)	.750 (19.1)	12
35	20	2	3.812 (96.8)	1.156 (29.4)	1.770 (45.0)	.625 (15.9)	.937 (23.8)	16
36	20	2	4.812 (122.2)	1.156 (29.4)	1.770 (45.0)	.625 (15.9)	.937 (23.8)	16
37	20	2	3.812 (96.8)	1.375 (34.9)	2.113 (53.7)	.875 (22.2)	1.250 (31.8)	20
38	20	2	4.812 (122.2)	1.375 (34.9)	2.113 (53.7)	.875 (22.2)	1.250 (31.8)	20
39	22	1	3.062 (77.8)	1.027 (26.1)	1.332 (33.8)	.350 (8.9)	.625 (15.9)	10
40	22	1	4.062 (103.2)	1.027 (26.1)	1.332 (33.8)	.350 (8.9)	.625 (15.9)	10
41	22	1	3.062 (77.8)	1.059 (26.9)	1.551 (39.4)	.500 (12.7)	.750 (19.1)	12
42	22	1	4.062 (103.2)	1.059 (26.9)	1.551 (39.4)	.500 (12.7)	.750 (19.1)	12
43	22	1	3.062 (77.8)	1.156 (29.4)	1.770 (45.0)	.625 (15.9)	.937 (23.8)	16
44	22	1	4.062 (103.2)	1.156 (29.4)	1.770 (45.0)	.625 (15.9)	.937 (23.8)	16
45	22	2	3.812 (96.8)	1.375 (34.9)	2.113 (53.7)	.875 (22.2)	1.250 (31.8)	20
46	22	2	4.812 (122.2)	1.375 (34.9)	2.113 (53.7)	.875 (22.2)	1.250 (31.8)	20
47	24	1	3.062 (77.8)	1.059 (26.9)	1.551 (39.4)	.500 (12.7)	.750 (19.1)	12
48	24	1	4.062 (103.2)	1.059 (26.9)	1.551 (39.4)	.500 (12.7)	.750 (19.1)	12
49	24	1	3.062 (77.8)	1.156 (29.4)	1.770 (45.0)	.625 (15.9)	.812 (20.6)	16
50	24	1	4.062 (103.2)	1.156 (29.4)	1.770 (45.0)	.625 (15.9)	.812 (20.6)	16
51	24	1	3.062 (77.8)	1.156 (29.4)	1.770 (45.0)	.625 (15.9)	.937 (23.8)	16
52	24	1	4.062 (103.2)	1.156 (29.4)	1.770 (45.0)	.625 (15.9)	.937 (23.8)	16

Continued on Page B-49

Dimensions in inches (millimeters) and are subject to change without notice.

AS85049/25 and MS3437C Straight EMI/RFI Non-Environmental Backshell



AS85049

B

TABLE II: Continued from Page B-48								
Dash No.	Shell Size	Style	E Max	F Ref.	L Max	Cable Range		M85049/42 Ref.
						Min	Max	
53	24	2	3.812 (96.8)	1.375 (34.9)	2.113 (53.7)	.875 (22.2)	1.250 (31.8)	20
54	24	2	4.812 (122.2)	1.375 (34.9)	2.113 (53.7)	.875 (22.2)	1.250 (31.8)	20
55	28	1	3.062 (77.8)	1.059 (26.9)	1.551 (39.4)	.500 (12.7)	.750 (19.1)	12
56	28	1	4.062 (103.2)	1.059 (26.9)	1.551 (39.4)	.500 (12.7)	.750 (19.1)	12
57	28	1	3.062 (77.8)	1.156 (29.4)	1.770 (45.0)	.625 (15.9)	.937 (23.8)	16
58	28	1	4.062 (103.2)	1.156 (29.4)	1.770 (45.0)	.625 (15.9)	.937 (23.8)	16
59	28	1	3.062 (77.8)	1.375 (34.9)	2.113 (53.7)	.875 (22.2)	1.250 (31.8)	20
60	28	1	4.062 (103.2)	1.375 (34.9)	2.113 (53.7)	.875 (22.2)	1.250 (31.8)	20
61	28	1	3.062 (77.8)	1.500 (38.1)	2.363 (60.0)	1.000 (25.4)	1.375 (34.9)	24
62	28	1	4.062 (103.2)	1.500 (38.1)	2.363 (60.0)	1.000 (25.4)	1.375 (34.9)	24
63	32	1	3.062 (77.8)	1.156 (29.4)	1.770 (45.0)	.625 (15.9)	.937 (23.8)	16
64	32	1	4.062 (103.2)	1.156 (29.4)	1.770 (45.0)	.625 (15.9)	.937 (23.8)	16
65	32	1	3.062 (77.8)	1.375 (34.9)	2.113 (53.7)	.875 (22.2)	1.250 (31.8)	20
66	32	1	4.062 (103.2)	1.375 (34.9)	2.113 (53.7)	.875 (22.2)	1.250 (31.8)	20
67	32	1	3.062 (77.8)	1.500 (38.1)	2.363 (60.0)	1.000 (25.4)	1.375 (34.9)	24
68	32	1	4.062 (103.2)	1.500 (38.1)	2.363 (60.0)	1.000 (25.4)	1.375 (34.9)	24
69	32	1	3.062 (77.8)	1.781 (45.2)	2.770 (70.4)	1.250 (31.8)	1.625 (41.3)	28
70	32	1	4.062 (103.2)	1.781 (45.2)	2.770 (70.4)	1.250 (31.8)	1.625 (41.3)	28
71	36	1	4.062 (103.2)	1.375 (34.9)	2.113 (53.7)	.875 (22.2)	1.250 (31.8)	20
72	36	1	5.062 (128.6)	1.375 (34.9)	2.113 (53.7)	.875 (22.2)	1.250 (31.8)	20
73	36	1	4.062 (103.2)	1.500 (38.1)	2.363 (60.0)	1.000 (25.4)	1.375 (34.9)	24
74	36	1	5.062 (128.6)	1.500 (38.1)	2.363 (60.0)	1.000 (25.4)	1.375 (34.9)	24
75	36	1	4.062 (103.2)	1.781 (45.2)	2.770 (70.4)	1.250 (31.8)	1.625 (41.3)	28
76	36	1	5.062 (128.6)	1.781 (45.2)	2.770 (70.4)	1.250 (31.8)	1.625 (41.3)	28
77	36	2	4.942 (125.5)	1.830 (46.5)	3.020 (76.7)	1.437 (36.5)	1.875 (47.6)	32
78	36	2	5.942 (150.9)	1.830 (46.5)	3.020 (76.7)	1.437 (36.5)	1.875 (47.6)	32
79	40	1	4.062 (103.2)	1.375 (34.9)	2.113 (53.7)	.875 (22.2)	1.250 (31.8)	20
80	40	1	5.062 (128.6)	1.375 (34.9)	2.113 (53.7)	.875 (22.2)	1.250 (31.8)	20
81	40	1	4.062 (103.2)	1.500 (38.1)	2.363 (60.0)	1.000 (25.4)	1.375 (34.9)	24
82	40	1	5.062 (128.6)	1.500 (38.1)	2.363 (60.0)	1.000 (25.4)	1.375 (34.9)	24
83	40	1	4.062 (103.2)	1.781 (45.2)	2.770 (70.4)	1.250 (31.8)	1.625 (41.3)	28
84	40	1	5.062 (128.6)	1.781 (45.2)	2.770 (70.4)	1.250 (31.8)	1.625 (41.3)	28
85	40	1	4.062 (103.2)	1.830 (46.5)	3.020 (76.7)	1.437 (36.5)	1.875 (47.6)	32
86	40	1	5.062 (128.6)	1.830 (46.5)	3.020 (76.7)	1.437 (36.5)	1.875 (47.6)	32
87	44	1	4.062 (103.2)	1.375 (34.9)	2.113 (53.7)	.875 (22.2)	1.250 (31.8)	20
88	44	1	5.062 (128.6)	1.375 (34.9)	2.113 (53.7)	.875 (22.2)	1.250 (31.8)	20
89	44	1	4.062 (103.2)	1.500 (38.1)	2.363 (60.0)	1.000 (25.4)	1.375 (34.9)	24
90	44	1	5.062 (128.6)	1.500 (38.1)	2.363 (60.0)	1.000 (25.4)	1.375 (34.9)	24
91	44	1	4.062 (103.2)	1.781 (45.2)	2.770 (70.4)	1.250 (31.8)	1.625 (41.3)	28
92	44	1	5.062 (128.6)	1.781 (45.2)	2.770 (70.4)	1.250 (31.8)	1.625 (41.3)	28
93	44	1	4.062 (103.2)	1.830 (46.5)	3.020 (76.7)	1.437 (36.5)	1.875 (47.6)	32
94	44	1	5.062 (128.6)	1.830 (46.5)	3.020 (76.7)	1.437 (36.5)	1.875 (47.6)	32
95	48	1	4.062 (103.2)	1.375 (34.9)	2.113 (53.7)	.875 (22.2)	1.250 (31.8)	20
96	48	1	5.062 (128.6)	1.375 (34.9)	2.113 (53.7)	.875 (22.2)	1.250 (31.8)	20
97	48	1	4.062 (103.2)	1.500 (38.1)	2.363 (60.0)	1.000 (25.4)	1.375 (34.9)	24
98	48	1	5.062 (128.6)	1.500 (38.1)	2.363 (60.0)	1.000 (25.4)	1.375 (34.9)	24
99	48	1	4.062 (103.2)	1.781 (45.2)	2.770 (70.4)	1.250 (31.8)	1.625 (41.3)	28
100	48	1	5.062 (128.6)	1.781 (45.2)	2.770 (70.4)	1.250 (31.8)	1.625 (41.3)	28
101	48	1	4.062 (103.2)	1.830 (46.5)	3.020 (76.7)	1.437 (36.5)	1.875 (47.6)	32
102	48	1	5.062 (128.6)	1.830 (46.5)	3.020 (76.7)	1.437 (36.5)	1.875 (47.6)	32
103	61	1	3.062 (77.8)	1.059 (26.9)	1.551 (39.4)	.500 (12.7)	.750 (19.1)	12
104	61	1	4.062 (103.2)	1.059 (26.9)	1.551 (39.4)	.500 (12.7)	.750 (19.1)	12

Continued on Page B-50

Dimensions in inches (millimeters) and are subject to change without notice.



AS85049/25 and MS3437C Straight EMI/RFI Non-Environmental Backshell

TABLE II: Continued from Page B-49

Dash No.	Shell Size	Style	E Max	F Ref.	L Max	Cable Range		M85049/42 Ref.
						Min	Max	
105	61	1	3.062 (77.8)	1.156 (29.4)	1.770 (45.0)	.625 (15.9)	.937 (23.8)	16
106	61	1	4.062 (103.2)	1.156 (29.4)	1.770 (45.0)	.625 (15.9)	.937 (23.8)	16
107	61	2	3.812 (96.8)	1.375 (34.9)	2.113 (53.7)	.875 (22.2)	1.250 (31.8)	20
108	61	2	4.812 (122.2)	1.375 (34.9)	2.113 (53.7)	.875 (22.2)	1.250 (31.8)	20
109	61	2	3.812 (96.8)	1.500 (38.1)	2.363 (60.0)	1.000 (25.4)	1.375 (34.9)	24
110	61	2	4.812 (122.2)	1.500 (38.1)	2.363 (60.0)	1.000 (25.4)	1.375 (34.9)	24
111	12	1	2.062 (52.4)	1.027 (26.1)	1.332 (33.8)	.350 (8.9)	.500 (12.7)	10
112	16	1	2.062 (52.4)	1.027 (26.1)	1.145 (29.1)	.250 (6.4)	.437 (11.1)	06
113	16	1	3.062 (77.8)	1.027 (26.1)	1.145 (29.1)	.250 (6.4)	.437 (11.1)	06
114	12	1	2.062 (52.4)	1.027 (26.1)	.957 (24.3)	.125 (3.2)	.312 (7.9)	04
115	12	1	3.062 (77.8)	1.027 (26.1)	.957 (24.3)	.125 (3.2)	.312 (7.9)	04
116	14	1	2.062 (52.4)	1.027 (26.1)	1.145 (29.1)	.250 (6.4)	.437 (11.1)	06
117	14	1	3.062 (77.8)	1.027 (26.1)	1.145 (29.1)	.250 (6.4)	.437 (11.1)	06
118	16	1	2.062 (52.4)	1.027 (26.1)	1.332 (33.8)	.350 (8.9)	.625 (15.9)	10
119	16	1	3.062 (77.8)	1.027 (26.1)	1.332 (33.8)	.350 (8.9)	.625 (15.9)	10
120	18	1	2.062 (52.4)	1.027 (26.1)	.957 (24.3)	.125 (3.2)	.312 (7.9)	04
121	18	1	3.062 (77.8)	1.027 (26.1)	.957 (24.3)	.125 (3.2)	.312 (7.9)	04
122	18	1	2.062 (52.4)	1.027 (26.1)	1.145 (29.1)	.250 (6.4)	.437 (11.1)	06
123	18	1	3.062 (77.8)	1.027 (26.1)	1.145 (29.1)	.250 (6.4)	.437 (11.1)	06
124	20	1	3.062 (77.8)	1.027 (26.1)	1.145 (29.1)	.250 (6.4)	.437 (11.1)	06
125	20	1	4.062 (103.2)	1.027 (26.1)	1.145 (29.1)	.250 (6.4)	.437 (11.1)	06
126	22	1	3.062 (77.8)	1.027 (26.1)	.957 (24.3)	.125 (3.2)	.312 (7.9)	04
127	22	1	4.062 (103.2)	1.027 (26.1)	.957 (24.3)	.125 (3.2)	.312 (7.9)	04
128	22	1	3.062 (77.8)	1.027 (26.1)	1.145 (29.1)	.250 (6.4)	.437 (11.1)	06
129	22	1	4.062 (103.2)	1.027 (26.1)	1.145 (29.1)	.250 (6.4)	.437 (11.1)	06
130	24	1	3.062 (77.8)	1.027 (26.1)	1.332 (33.8)	.350 (8.9)	.625 (15.9)	10
131	24	1	4.062 (103.2)	1.027 (26.1)	1.332 (33.8)	.350 (8.9)	.625 (15.9)	10
132	36	1	4.062 (103.2)	1.059 (26.9)	1.551 (39.4)	.500 (12.7)	.750 (19.1)	12
133	36	1	5.062 (128.6)	1.059 (26.9)	1.551 (39.4)	.500 (12.7)	.750 (19.1)	12
134	40	1	4.062 (103.2)	1.059 (26.9)	1.551 (39.4)	.500 (12.7)	.750 (19.1)	12
135	40	1	5.062 (128.6)	1.059 (26.9)	1.551 (39.4)	.500 (12.7)	.750 (19.1)	12
136	10	1	2.062 (52.4)	1.027 (26.1)	1.145 (29.1)	.250 (6.4)	.375 (9.5)	06
137	10	1	3.062 (77.8)	1.027 (26.1)	1.145 (29.1)	.250 (6.4)	.375 (9.5)	06
138	12	1	2.062 (52.4)	1.027 (26.1)	1.332 (33.8)	.350 (8.9)	.500 (12.7)	10
139	12	1	3.062 (77.8)	1.027 (26.1)	1.332 (33.8)	.350 (8.9)	.500 (12.7)	10
140	20	1	3.062 (77.8)	1.156 (29.4)	1.770 (45.0)	.625 (15.9)	.904 (23.0)	16
141	20	1	4.062 (103.2)	1.156 (29.4)	1.770 (45.0)	.625 (15.9)	.904 (23.0)	16
142	22	1	3.062 (77.8)	1.375 (34.9)	2.113 (53.7)	.875 (22.2)	1.029 (26.1)	20
143	22	1	4.062 (103.2)	1.375 (34.9)	2.113 (53.7)	.875 (22.2)	1.029 (26.1)	20
144	24	1	3.062 (77.8)	1.375 (34.9)	2.113 (53.7)	.875 (22.2)	1.144 (29.1)	20
145	24	1	4.062 (103.2)	1.375 (34.9)	2.113 (53.7)	.875 (22.2)	1.144 (29.1)	20
146	36	1	4.062 (103.2)	1.830 (46.5)	3.020 (76.7)	1.437 (36.5)	1.840 (46.7)	32
147	36	1	5.062 (128.6)	1.830 (46.5)	3.020 (76.7)	1.437 (36.5)	1.840 (46.7)	32
148	36	1	4.062 (103.2)	1.156 (29.4)	1.770 (45.0)	.625 (15.9)	.937 (23.8)	16
149	36	1	5.062 (128.6)	1.156 (29.4)	1.770 (45.0)	.625 (15.9)	.937 (23.8)	16
150	14	1	2.062 (52.4)	1.027 (26.1)	.957 (24.3)	.125 (3.2)	.312 (7.9)	04
151	14	1	3.062 (77.8)	1.027 (26.1)	.957 (24.3)	.125 (3.2)	.312 (7.9)	04
152	16	1	2.062 (52.4)	1.027 (26.1)	.957 (24.3)	.125 (3.2)	.312 (7.9)	04
153	16	1	3.062 (77.8)	1.027 (26.1)	.957 (24.3)	.125 (3.2)	.312 (7.9)	04
154	44	1	4.062 (103.2)	1.156 (29.4)	1.770 (45.0)	.625 (15.9)	.937 (23.8)	16
155	44	1	5.062 (128.6)	1.156 (29.4)	1.770 (45.0)	.625 (15.9)	.937 (23.8)	16
156	40	1	4.062 (103.2)	1.156 (29.4)	1.770 (45.0)	.625 (15.9)	.937 (23.8)	16
157	40	1	5.062 (128.6)	1.156 (29.4)	1.770 (45.0)	.625 (15.9)	.937 (23.8)	16

Dimensions in inches (millimeters) and are subject to change without notice.

AS85049/26-1 and MS3419 Straight Crimp Ring Backshell and Crimp Ring



AS85049

CONNECTOR DESIGNATOR:	
A	AS50151 Series AS34001
	MIL-DTL-26482 Series II
	AS81703 Series III
	MIL-DTL-83723 Series I & III

Basic Part Number
M85049/26-1 = Adapter Only
M85049/26-2 = Crimp Ring Only
M85049/26-3 = Adapter with Crimp Ring
 (See Page B-52 for Crimp Ring)

Shell Size
 (Table II)

M85049/26-1 - 12 W

Superseded Part Number

MS3419-21 C

Basic Part No.	Shell Size
----------------	------------

Finish
 (Material is Aluminum Only)
A = Electroless Nickel
C = 500 Hr. Cadmium Olive Drab over Electroless Nickel

B

Finish
N = Electroless Nickel
W = 1,000 Hr. Cadmium Olive Drab over Electroless Nickel
X = Aluminum, Nickel Fluorocarbon Polymer
Z = Aluminum, Zinc-Nickel, Black

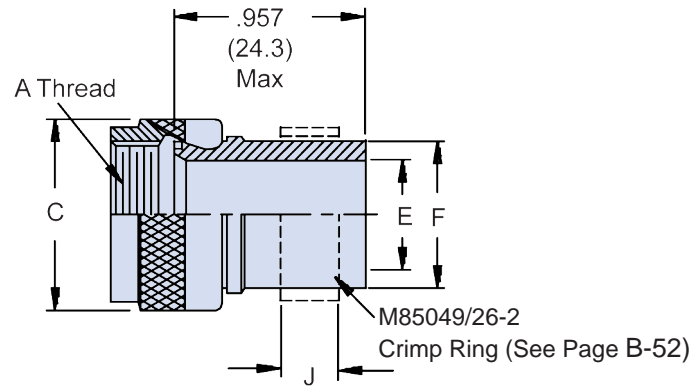
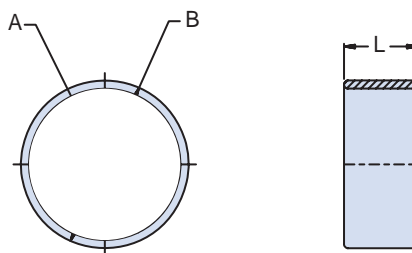
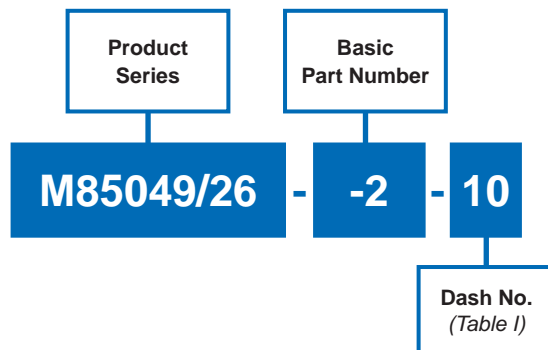

TABLE I: Adapter Shell Size, Thread, and Dimensions				
Shell Size	A Thread Class 2B	C Dia Max	E Dia	F Dia
3	.562 - 24 UNEF	.670 (17.0)	.250 (6.4)	.337 (8.6)
8	.500 - 20 UNF	.620 (15.7)	.250 (6.4)	.337 (8.6)
10	.625 - 24 UNEF	.730 (18.5)	.325 (8.3)	.488 (12.4)
12	.750 - 20 UNEF	.860 (21.8)	.420 (10.7)	.500 (12.7)
14	.875 - 20 UNEF	.980 (24.9)	.540 (13.7)	.620 (15.7)
16	1.000 - 20 UNEF	1.110 (28.2)	.670 (17.0)	.750 (19.1)
18	1.062 - 18 UNEF	1.220 (31.0)	.789 (20.0)	.880 (22.4)
20	1.188 - 18 UNEF	1.350 (34.3)	.914 (23.2)	1.000 (25.4)
22	1.313 - 18 UNEF	1.470 (37.3)	1.039 (26.4)	1.120 (28.4)
24	1.438 - 18 UNEF	1.590 (40.4)	1.112 (28.2)	1.192 (30.3)
28	1.750 - 18 UNS	1.970 (50.0)	1.389 (35.3)	1.545 (39.2)
32	2.000 - 18 UNS	2.220 (56.4)	1.635 (41.5)	1.795 (45.6)
36	2.250 - 16 UN	2.470 (62.7)	1.850 (47.0)	2.045 (51.9)
40	2.500 - 16 UN	2.720 (69.1)	2.065 (52.5)	2.295 (58.3)
44	2.750 - 16 UN	2.970 (75.4)	2.320 (58.9)	2.545 (64.6)
48	3.000 - 16 UN	3.220 (81.8)	2.570 (65.3)	2.795 (71.0)
61	1.500 - 18 UNEF	1.650 (41.9)	1.210 (30.7)	1.359 (34.5)

- APPLICATION NOTES**
- For complete dimensions see the applicable Military Specification.
 - Metric dimensions (mm) are in parentheses.

See Page B-52 for AS85049/26-2 Crimp Ring

Dimensions in inches (millimeters) and are subject to change without notice.

TABLE I: Shell Size, Thread, Cable Entry and Dimensions

Dash No.	Color Code	A Dia		B Dia		L Dim ±.020 (0.5)	For Use with AS85049/26-1	For Use with AS85049/20	For Use with AS85049/33-2	Installing Die Cat. No. (See Note 2)
		Min	Max	Min	Max					
8	GREEN	.400 (10.2)	.410 (10.4)	.448 (11.4)	.458 (11.6)	.250 (6.4)	-3 & -8	-9	-8	GS405
10	RED	.585 (14.9)	.595 (15.1)	.660 (16.8)	.680 (17.3)	.440 (11.2)	-10	-11	-10	GS590
12	RED	.585 (14.9)	.595 (15.1)	.660 (16.8)	.680 (17.3)	.440 (11.2)	-12	-11	-10	GS590
14	BLUE	.705 (17.9)	.715 (18.2)	.780 (19.8)	.800 (20.3)	.440 (11.2)	-14	-15	-14	GS710
16	GREY	.835 (21.2)	.845 (21.5)	.910 (23.1)	.930 (23.6)	.440 (11.2)	-16	-17	-16	GS840
18	BROWN	1.005 (25.5)	1.015 (25.8)	1.080 (27.4)	1.100 (27.9)	.440 (11.2)	-18	-19	-18	GS1010
20	GREEN	1.125 (28.6)	1.135 (28.8)	1.200 (30.5)	1.220 (31.0)	.440 (11.2)	-20	-21	-20	GS1130
22	PINK	1.245 (31.6)	1.255 (31.9)	1.320 (33.5)	1.340 (34.0)	.440 (11.2)	-22	-23	-22	GS1250
24	ORANGE	1.327 (33.7)	1.337 (34.0)	1.402 (35.6)	1.422 (36.1)	.440 (11.2)	-24	-25	-24	GS1332
28	RED	1.665 (42.3)	1.675 (42.5)	1.740 (44.2)	1.760 (44.7)	.440 (11.2)	-28			GS1670
32	GREY	1.915 (48.6)	1.925 (48.9)	1.990 (50.5)	2.010 (51.4)	.440 (11.2)	-32			GS1920
36	GREEN	2.165 (55.0)	2.175 (55.2)	2.240 (56.9)	2.260 (57.4)	.440 (11.2)	-36			GS2170
40	ORANGE	2.415 (61.3)	2.425 (61.6)	2.490 (63.2)	2.510 (63.8)	.440 (11.2)	-40			GS2420
44	YELLOW	2.665 (67.7)	2.675 (67.9)	2.740 (69.6)	2.760 (70.1)	.440 (11.2)	-44			GS2670
48	BLUE	2.915 (74.0)	2.925 (74.3)	2.990 (75.9)	3.010 (76.5)	.440 (11.2)	-48			GS2920
61	PURPLE	1.435 (36.4)	1.445 (36.7)	1.510 (38.4)	1.530 (38.9)	.440 (11.2)	-61			GS1440

APPLICATION NOTES

1. Assembly identified with manufacturer's name and part number, space permitting.
2. Crimp tool shall be the Thomas and Betts Installing Head catalog number 13640 or equivalent (see Table I).
3. The installing dies (Thomas and Betts Cat. No.--See Table I) shall be used with the Thomas and Betts Installing head Catalog Number 13640 or an equivalent tool.
4. Material/Finish: Copper/Tin Plate.
5. Metric dimensions (mm) are in parentheses.

Dimensions in inches (millimeters) and are subject to change without notice.

AS85049/27 and M38999/1 Self-Locking and Non-Self-Locking E-Nut



AS85049

B

CONNECTOR DESIGNATOR:	
F	MIL-DTL-27599, MIL-DTL-38999 Series I & II

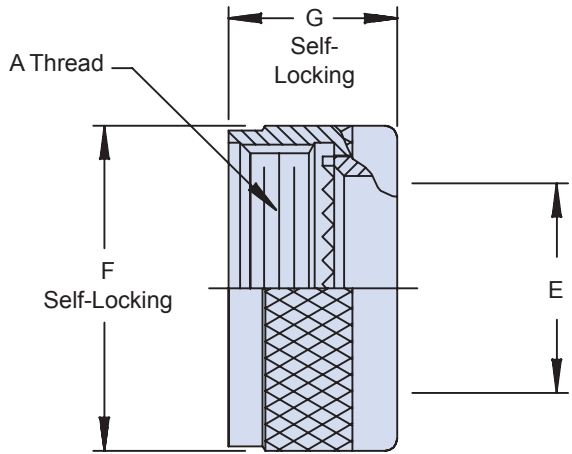
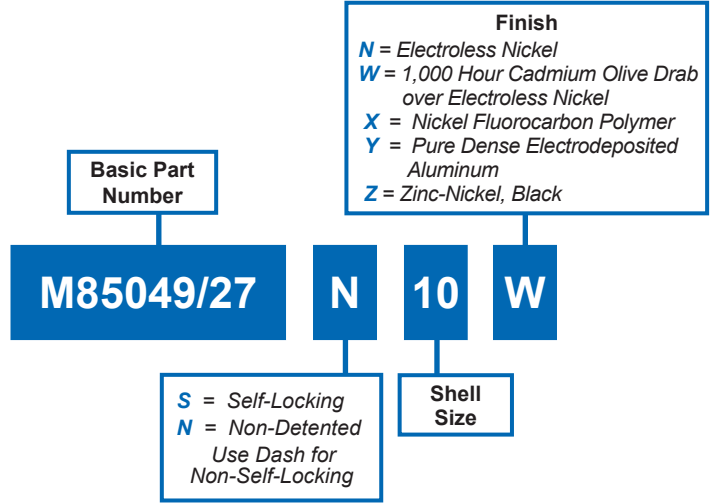

Shell Size	A Thread Class 2B	Ø E Max	Ø F Max	G Max
08	.438 - 28 UNEF	.274 (7.0)	.859 (21.8)	.590 (15.0)
10	.562 - 24 UNEF	.412 (10.5)	.984 (25.0)	.590 (15.0)
12	.688 - 24 UNEF	.526 (13.4)	1.156 (29.4)	.590 (15.0)
14	.813 - 20 UNEF	.651 (16.5)	1.281 (32.5)	.590 (15.0)
16	.938 - 20 UNEF	.776 (19.7)	1.406 (35.7)	.590 (15.0)
18	1.063 - 18 UNEF	.882 (22.4)	1.516 (38.5)	.590 (15.0)
20	1.188 - 18 UNEF	1.006 (25.6)	1.641 (41.7)	.590 (15.0)
22	1.313 - 18 UNEF	1.132 (28.8)	1.766 (44.9)	.590 (15.0)
24	1.438 - 18 UNEF	1.257 (31.9)	1.891 (48.0)	.590 (15.0)

- APPLICATION NOTES**
- For complete dimensions, see the applicable Military Specification.
 - Metric dimensions (mm) are indicated in parentheses.

Dimensions in inches (millimeters) and are subject to change without notice.

© 2013 Glenair, Inc. Mil-Spec Backshells U.S. CAGE Code 06324 Rev. 8.29.14 Printed in U.S.A.

Basic
Part Number

Dash Number
(Table II)

M85049/28 - 1

Superseded
Part Number

M83733/15 1

Basic
Part No.

Dash No.
(Table II)

**TABLE I:
Shell Size and Dimensions**

Dash No.	Shell Size	A Max Dim	B Dim	C Cable Range (See Note 4)
1	A	2.126 (54.0)	1.900 (48.3) 1.890 (48.0)	.625 (15.9) .500 (12.7)
2	A	2.126 (54.0)	1.900 (48.3) 1.890 (48.0)	.750 (19.1) .625 (15.9)
3	B	3.426 (87.0)	3.200 (81.3) 3.190 (81.0)	.625 (15.9) .500 (12.7)
4	B	3.426 (87.0)	3.200 (81.3) 3.190 (81.0)	.750 (19.1) .625 (15.9)

B

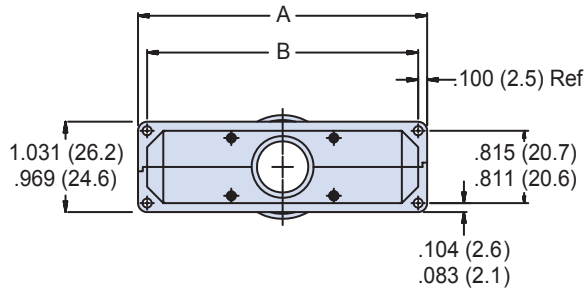
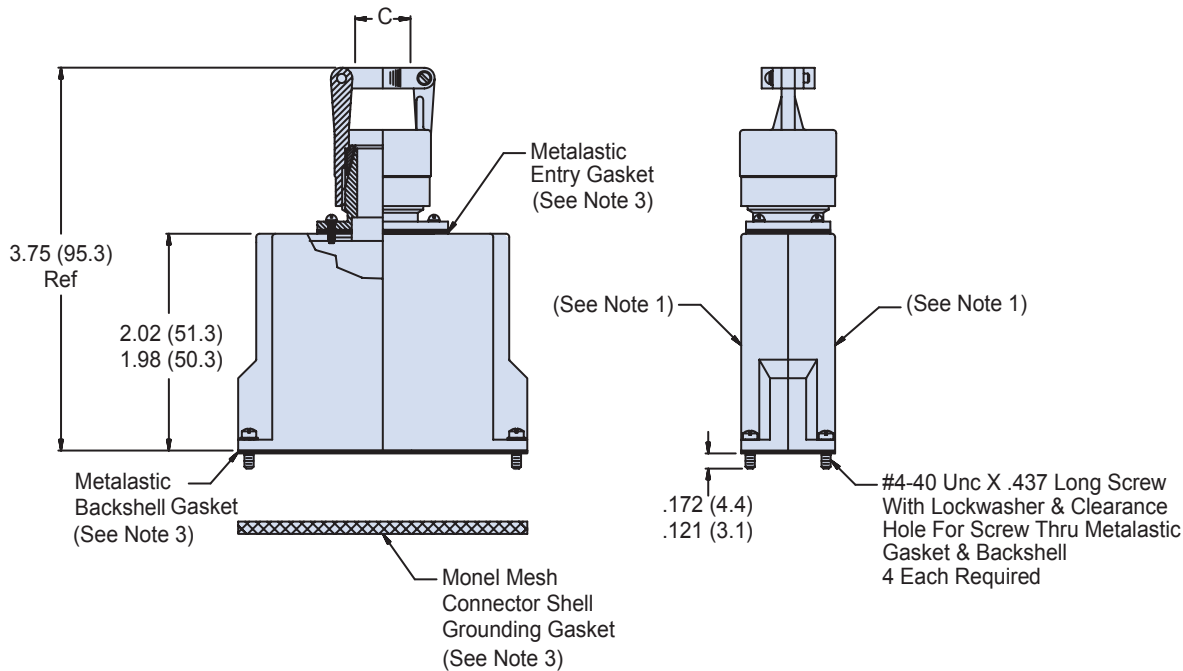

APPLICATION NOTES

1. Assembly identified with manufacturer's name and part number, space permitting, location optional.
2. Glenair Series 600 Backshell Assembly Tools are recommended for assembly and installation.
3. Gasket may be ordered as a kit (Glenair G61659), shell size A or B.
4. Dash numbers 1 and 3 = Standard cable entry.
Dash numbers 2 and 4 = Oversize cable entry.
5. Material/finish:
Backshell, adapter, clamp, ferrule - Al alloy/Electroless nickel.
Screws and washers -CRES/Passivate
Backshell and entry gaskets = Metalastic/N.A.
Interface gasket - Monel mesh/N.A.
6. Metric dimensions (mm) are indicated in parentheses

Dimensions in inches (millimeters) and are subject to change without notice.

AS85049/29 (M38999/6) Straight Non-Environmental Strain Relief Backshell



AS85049

B

CONNECTOR DESIGNATOR:	
F	MIL-DTL-38999 Series I and II

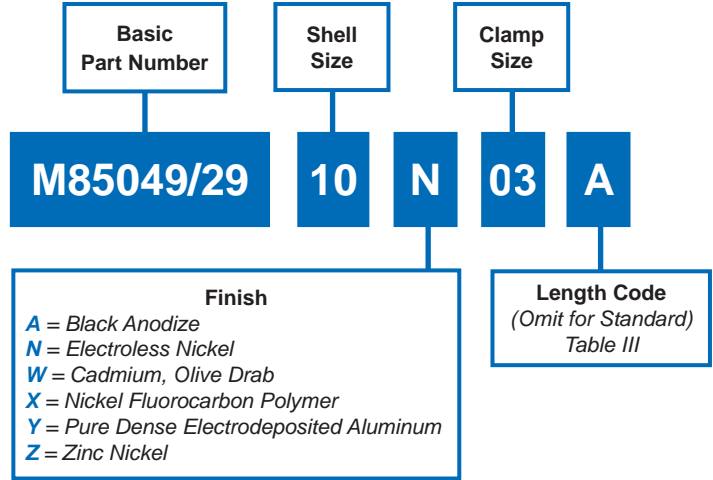

Code	Length ± .032 (0.8)
Standard	1.00 (25.4)
A	2.00 (50.8)
B	3.00 (76.2)
C	4.00 (101.6)

- APPLICATION NOTES**
- For complete dimensions see the applicable Military Specification.
 - Metric dimensions (mm) are in parentheses.
 - Cable Range is defined as the accommodation range for the wire bundle or cable. Dimensions shown are not intended for inspection criteria.

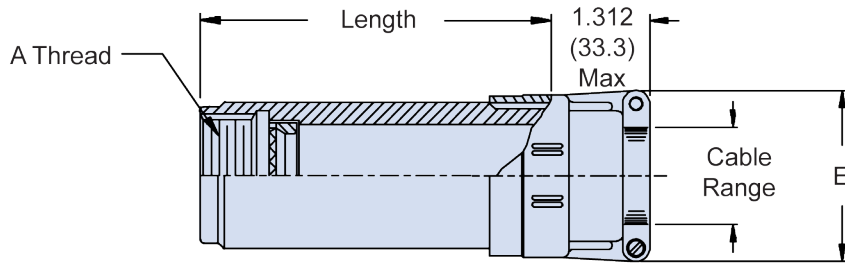

Shell Size	Series I Ref.	Clamp Size*		A Thread Class 2B
		Min	Max	
08	09	01	02	.438 - 28 UNEF
10	11	01	03	.562 - 24 UNEF
12	13	02	04	.688 - 24 UNEF
14	15	02	05	.813 - 20 UNEF
16	17	02	06	.938 - 20 UNEF
18	19	03	07	1.063 - 18 UNEF
20	21	03	08	1.188 - 18 UNEF
22	23	03	09	1.313 - 18 UNEF
24	25	04	10	1.438 - 18 UNEF

*Clamp Size from Table II, AS85049/29 Specifications.

Clamp Size	Cable Range		E Max
	Min	Max	
01	.062 (1.6)	.125 (3.2)	.781 (19.8)
02	.125 (3.2)	.250 (6.4)	.969 (24.6)
03	.250 (6.4)	.375 (9.5)	1.062 (27.0)
04	.312 (7.9)	.500 (12.7)	1.156 (29.4)
05	.437 (11.1)	.625 (15.9)	1.250 (31.8)
06	.562 (14.3)	.750 (19.1)	1.375 (34.9)
07	.687 (17.4)	.875 (22.2)	1.500 (38.1)
08	.812 (20.6)	1.000 (25.4)	1.625 (41.3)
09	.937 (23.8)	1.125 (28.6)	1.750 (44.5)
10	1.062 (27.0)	1.250 (31.8)	1.875 (47.6)

Dimensions in inches (millimeters) and are subject to change without notice.



AS85049/30 and M38999/4 Straight TAG® Ring Backshell

CONNECTOR DESIGNATOR:
F MIL-DTL-38999 Series I and II

**Basic
Part Number**
**Shell Size
(Table II)**
M85049/30 - 10 W
**Superseded
Part Number**
M38999/4 12 B
**Basic
Part No.**
**Shell
Size**
**Finish
(Material is Aluminum Only)**
B = Cadmium Olive Drab over Nickel
F = Electroless Nickel

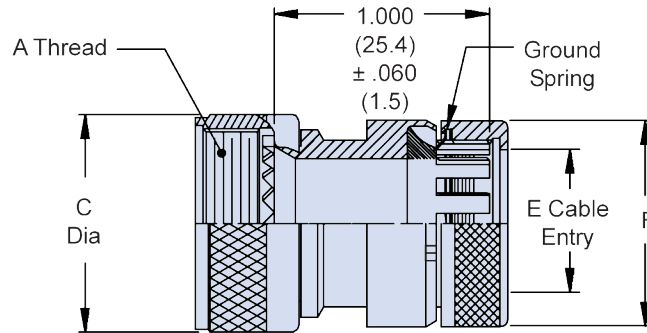
Finish
N = Electroless Nickel
W = 1,000 Hr. Cadmium Olive Drab over Electroless Nickel
X = Aluminum, Nickel Fluorocarbon Polymer
Z = Aluminum, Zinc-Nickel, Black

TABLE I: Clamp Size, Cable Range and Dimensions

Shell Size	Shell Size Series I Ref	A Thread Class 2B	C Dia Max	E Cable Entry Max	F Dia Max
08	9	.438 - 28 UNEF	.75 (19.1)	.250 (6.4)	.545 (13.8)
10	11	.562 - 24 UNEF	.85 (21.6)	.375 (9.5)	.670 (17.0)
12	13	.688 - 24 UNEF	1.00 (25.4)	.500 (12.7)	.795 (20.2)
14	15	.813 - 20 UNEF	1.10 (27.9)	.625 (15.9)	.920 (23.4)
16	17	.938 - 20 UNEF	1.25 (31.8)	.750 (19.1)	1.045 (26.5)
18	19	1.063 - 18 UNEF	1.40 (35.6)	.844 (21.4)	1.170 (29.7)
20	21	1.188 - 18 UNEF	1.50 (38.1)	.970 (24.6)	1.295 (32.9)
22	23	1.313 - 18 UNEF	1.65 (41.9)	1.094 (27.8)	1.420 (36.1)
24	25	1.438 - 18 UNEF	1.75 (44.5)	1.219 (31.0)	1.670 (42.4)

APPLICATION NOTES

- For complete dimensions see the applicable Military Specification.
- Metric dimensions (mm) are in parentheses.
- Cable Entry is defined as the accommodation range for the wire bundle or cable. Dimensions shown are not intended for inspection criteria.

Dimensions in inches (millimeters) and are subject to change without notice.

AS85049/31, MS3416 and MIL-DTL-85723/15N Self-Locking and Non-Self-Locking E-Nut



AS85049

B

CONNECTOR DESIGNATOR:

A

AS50151 Series AS34001 Crimp,
MIL-DTL-26482 Series II,
SAE AS81703 Crimp Series III,
MIL-DTL-83723 Series I,
MIL-DTL-83723 Series III

Finish

A = Anodize, Black
N = Electroless Nickel
W = 1,000 Hour Cadmium Olive Drab
over Electroless Nickel
X = Nickel Fluorocarbon Polymer
Y = Pure Dense Electrodeposited
Aluminum
Z = Zinc-Nickel, Black

Basic Part
Number

M85049/31

S

22

W

S = Self-Locking
N = Non-Detented
Use Dash for
Non-Self-Locking

Shell
Size

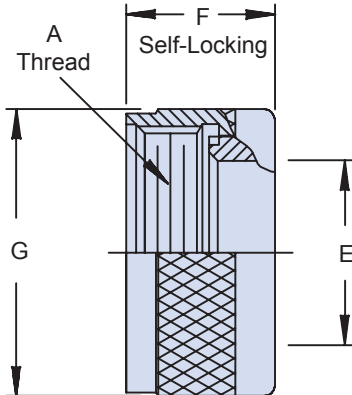

Superseded Part Number

M83723/15N-10 A

Basic Part No.
(Non-Self-
Locking Only)

Dash
No.

Finish Designator
A = Non-Conductive, Black Anodize
R = Conductive, Electroless Nickel

Superseded Part Number

MS3416 -10-E A

Basic Part No.
(Non-Self-
Locking Only)

Dash No.

Style

Metal and Finish Designator
A = Aluminum 500 Hour Cad. Olive
Drab Over Electroless Nickel
C = Aluminum, Cadmium Olive Drab
G = Aluminum, Black Anodize
N = Aluminum, Electroless Nickel

TABLE I: Shell Size, Thread and Dimensions

Shell Size	A Thread Class 2B	Ø E Max	F Max	Ø G Max
3	.562 - 24 UNEF	.270 (6.9)	--	--
8	.500 - 20 UNF	.270 (6.9)	.710 (18.0)	.885 (22.5)
10	.625 - 24 UNEF	.375 (9.5)	.710 (18.0)	1.010 (25.7)
12	.750 - 20 UNEF	.511 (13.0)	.710 (18.0)	1.135 (28.8)
14	.875 - 20 UNEF	.585 (14.9)	.710 (18.0)	1.260 (32.0)
16	1.000 - 20 UNEF	.710 (18.0)	.710 (18.0)	1.385 (35.2)
18	1.062 - 18 UNEF	.789 (20.0)	.710 (18.0)	1.510 (38.4)
20	1.188 - 18 UNEF	.914 (23.2)	.710 (18.0)	1.635 (41.5)
22	1.313 - 18 UNEF	1.039 (26.4)	.710 (18.0)	1.760 (44.7)
24	1.438 - 18 UNEF	1.154 (29.3)	.710 (18.0)	1.885 (47.9)
28	1.750 - 18 UNS	1.389 (35.3)	.890 (22.6)	2.135 (54.2)
32	2.000 - 18 UNS	1.635 (41.5)	.890 (22.6)	2.395 (60.8)
36	2.250 - 16 UN	1.850 (47.0)	.890 (22.6)	2.635 (66.9)
40	2.500 - 16 UN	2.065 (52.5)	.890 (22.6)	2.885 (73.3)
44	2.750 - 16 UN	2.320 (58.9)	.890 (22.6)	3.135 (79.6)
48	3.000 - 16 UN	2.570 (65.3)	.890 (22.6)	3.385 (86.0)
61	1.500 - 18 UNEF	1.194 (30.3)	--	--

APPLICATION NOTES

- For complete dimensions, see the applicable Military Specification.
- Metric dimensions (mm) are indicated in parentheses.

Dimensions in inches (millimeters) and are subject to change without notice.

© 2013 Glenair, Inc.

Mil-Spec Backshells

U.S. CAGE Code 06324

Rev. 8.29.14

Printed in U.S.A.

CONNECTOR DESIGNATOR:

F MIL-DTL-38999 Series I and II

**Basic
Part Number**
**Shell Size
(Table I)**
M85049/33-2
10
W

Finish

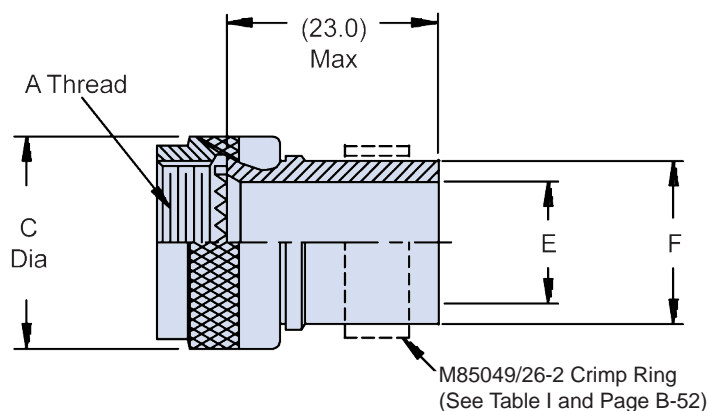
N = Electroless Nickel
W = 1,000 Hr. Cadmium Olive Drab over Electroless Nickel
X = Aluminum, Nickel Fluorocarbon Polymer
Z = Aluminum, Zinc-Nickel, Black

TABLE I: Adapter Shell Size, Thread, Dimensions and Crimp Ring Ref.

Shell Size	A Thread Class 2B	C Dia Max	E Dia	F Dia Max	AS85049/26-2 Crimp Ring Ref
08	.438 - 28 UNEF	.750 (19.1)	.250 (6.4)	.347 (8.8)	8
10	.562 - 24 UNEF	.850 (21.6)	.325 (8.3)	.498 (12.6)	10
12	.688 - 24 UNEF	1.000 (25.4)	.420 (10.7)	.510 (13.0)	12
14	.813 - 20 UNEF	1.100 (27.9)	.540 (13.7)	.630 (16.0)	14
16	.938 - 20 UNEF	1.250 (31.8)	.670 (17.0)	.760 (19.3)	16
18	1.063 - 18 UNEF	1.400 (35.6)	.789 (20.0)	.890 (22.6)	18
20	1.188 - 18 UNEF	1.500 (38.1)	.914 (23.2)	1.010 (25.7)	20
22	1.313 - 18 UNEF	1.650 (41.9)	1.039 (26.4)	1.130 (28.7)	22
24	1.438 - 18 UNEF	1.750 (44.5)	1.112 (28.2)	1.202 (30.5)	24

APPLICATION NOTES

1. For complete dimensions see the applicable Military Specification.
2. Metric dimensions (mm) are in parentheses.

**See Page B-52 for
AS85049/26-2 Crimp Ring**

Dimensions in inches (millimeters) and are subject to change without notice.

AS85049/34
Straight Adapter and Extender
 for Use with MS3114 and MS3124 Connectors



AS85049

CONNECTOR DESIGNATOR:	
D	MIL-DTL-26482 Series I

For Use With
 MS3114 and MS3124
 Connectors Only

Basic Part Number	Shell Size (Table I)
M85049/34	- 12 W
Finish <i>W = 1000 Hr. Cadmium Olive Drab</i> <i>X = Nickel Fluorocarbon Polymer</i> <i>Y = Pure Dense Electrodeposited Aluminum</i> <i>Z = Zinc Nickel, Black</i>	

B

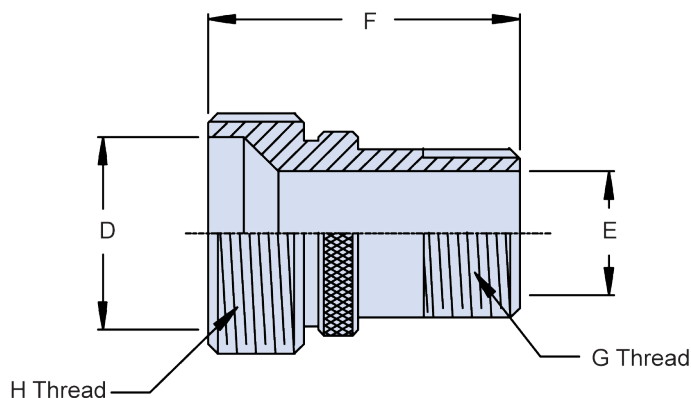

Shell Size	G Thread UNEF Class 2A	H Thread UNEF Class 2A	D Dia	E Dia	F Max
8	.4375 - 28	.625 - 24	.500 (12.7)	.327 (8.3)	.812 (20.6)
10	.5625 - 24	.750 - 20	.609 (15.5)	.444 (11.3)	.812 (20.6)
12	.6875 - 24	.875 - 20	.734 (18.6)	.569 (14.5)	.812 (20.6)
14	.8125 - 20	1.000 - 20	.859 (21.8)	.673 (17.1)	.812 (20.6)
16	.9375 - 20	1.125 - 18	.969 (24.6)	.798 (20.3)	.812 (20.6)
18	1.0625 - 18	1.250 - 18	1.109 (28.2)	.915 (23.2)	.812 (20.6)
20	1.1875 - 18	1.375 - 18	1.219 (31.0)	1.030 (26.2)	.906 (23.0)
22	1.3125 - 18	1.500 - 18	1.344 (34.1)	1.155 (29.3)	.906 (23.0)
24	1.4375 - 18	1.625 - 18	1.469 (37.3)	1.280 (32.5)	.937 (23.8)

APPLICATION NOTES
1. For complete dimensions see the applicable Military Specification.
2. Metric dimensions (mm) are in parentheses.

Dimensions in inches (millimeters) and are subject to change without notice.



AS85049/36 and M38999/7 Straight EMI/RFI Non-Environmental Backshell

CONNECTOR DESIGNATOR:

F MIL-DTL-38999 Series I and II

Finish

N = Electroless Nickel
W = 1,000 Hr. Cadmium Olive Drab over Electroless Nickel
X = Nickel Fluorocarbon Polymer
Z = Zinc-Nickel, Black

B

M85049/36

10

N

03

A

Basic
Part Number

Shell Size
(Table I)

Clamp Size
(Table I)

Length
Code
(Omit for
Standard)

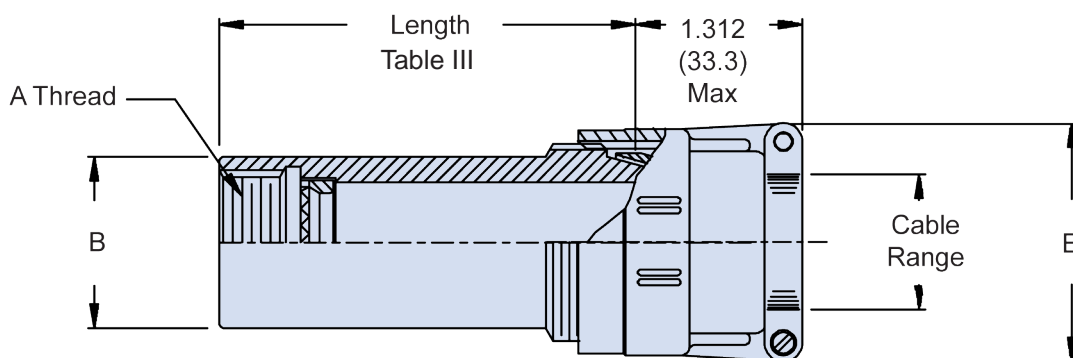

TABLE I: Shell Size and Clamp Size

Shell Size	Series I Shell Size Ref.	Clamp Size (Table II)		A Thread Class 2B	B Dia Max
		Min	Max		
08	09	01	02	.438 - 28 UNEF	.65 (16.5)
10	11	01	03	.562 - 24 UNEF	.77 (19.6)
12	13	02	04	.688 - 24 UNEF	.89 (22.6)
14	15	02	05	.813 - 20 UNEF	1.02 (25.9)
16	17	02	06	.938 - 20 UNEF	1.15 (29.2)
18	19	03	07	1.063 - 18 UNEF	1.23 (31.2)
20	21	03	08	1.188 - 18 UNEF	1.36 (34.5)
22	23	03	09	1.313 - 18 UNEF	1.48 (37.6)
24	25	04	10	1.438 - 18 UNEF	1.73 (43.9)

TABLE II: Cable Range and Dimensions

Clamp Size	Cable Range		E Max
	Min	Max	
01	.062 (1.6)	.125 (3.2)	.781 (19.8)
02	.125 (3.2)	.250 (6.4)	.969 (24.6)
03	.250 (6.4)	.375 (9.5)	1.062 (27.0)
04	.312 (7.9)	.500 (12.7)	1.156 (29.4)
05	.437 (11.1)	.625 (15.9)	1.250 (31.8)
06	.562 (14.3)	.750 (19.1)	1.375 (34.9)
07	.687 (17.4)	.875 (22.2)	1.500 (38.1)
08	.812 (20.6)	1.000 (25.4)	1.625 (41.3)
09	.937 (23.8)	1.125 (28.6)	1.750 (44.5)
10	1.062 (27.0)	1.250 (31.8)	1.875 (47.6)

TABLE III: Length Code

Length Code	Available Shell Sizes	Length
Std.	08 - 24	1.500 (38.1)
A	08 - 24	2.500 (63.5)
B	14 - 24	3.500 (88.9)
C	20 - 24	4.500 (114.3)

APPLICATION NOTES

- For complete dimensions see the applicable Military Specification.
- Metric dimensions (mm) are in parentheses.
- Cable Range is defined as the accommodation range for the wire bundle or cable. Dimensions shown are not intended for inspection criteria.

Dimensions in inches (millimeters) and are subject to change without notice.

AS85049/37 and M38999/8 90° EMI/RFI Non-Environmental Backshell



AS85049

B

CONNECTOR DESIGNATOR:

F MIL-DTL-38999 Series I and II

Finish
N = Electroless Nickel *X* = Nickel Fluorocarbon Polymer
W = 1,000 Hr. Cadmium Olive Drab over Electroless Nickel *Z* = Zinc-Nickel, Black

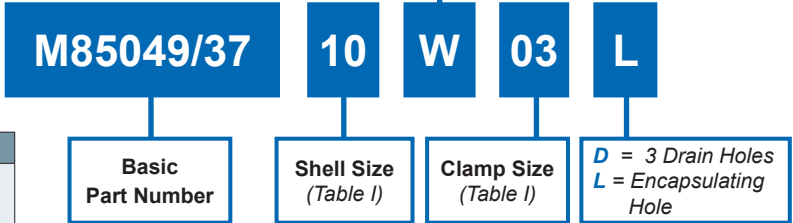

TABLE I: Shell Size

Shell Size Series II	Series I Shell Size Ref.	A Thread Class 2B	C Dia Max
08	09	.438 - 28 UNEF	.750 (19.1)
10	11	.562 - 24 UNEF	.850 (21.6)
12	13	.688 - 24 UNEF	1.000 (25.4)
14	15	.813 - 20 UNEF	1.100 (27.9)
16	17	.938 - 20 UNEF	1.250 (31.8)
18	19	1.063 - 18 UNEF	1.400 (35.6)
20	21	1.188 - 18 UNEF	1.500 (38.1)
22	23	1.313 - 18 UNEF	1.650 (41.9)
24	25	1.438 - 18 UNEF	1.750 (44.5)

TABLE II: Clamp Size and Dimensions

Shell Size Series II	Series I Shell Size Ref.	E Max	F Max	Clamp Size Min	Clamp Size Max
8	09	.720 (18.3)	2.50 (63.5)	01	02
10	11	.720 (18.3)	2.50 (63.5)	01	03
12	13	.800 (20.3)	2.56 (65.0)	02	04
14	15	.850 (21.6)	2.69 (68.3)	02	05
16	17	.910 (23.1)	2.81 (71.4)	02	06
18	19	1.000 (25.4)	3.03 (77.0)	03	06
20	21	1.050 (26.7)	3.19 (81.0)	03	07
22	23	1.100 (27.9)	3.31 (84.1)	03	08
24	25	1.200 (30.5)	3.31 (84.1)	04	09

TABLE II: Clamp Size and Dimensions

Clamp Size	Cable Range		G Max
	Min	Max	
01	.062 (1.6)	.125 (3.2)	.781 (19.8)
02	.125 (3.2)	.250 (6.4)	.969 (24.6)
03	.250 (6.4)	.375 (9.5)	1.062 (27.0)
04	.312 (7.9)	.500 (12.7)	1.156 (29.4)
05	.437 (11.1)	.625 (15.9)	1.250 (31.8)
06	.562 (14.3)	.750 (19.1)	1.375 (34.9)
07	.687 (17.4)	.875 (22.2)	1.500 (38.1)
08	.812 (20.6)	1.000 (25.4)	1.625 (41.3)
09	.937 (23.8)	1.125 (28.6)	1.750 (44.5)

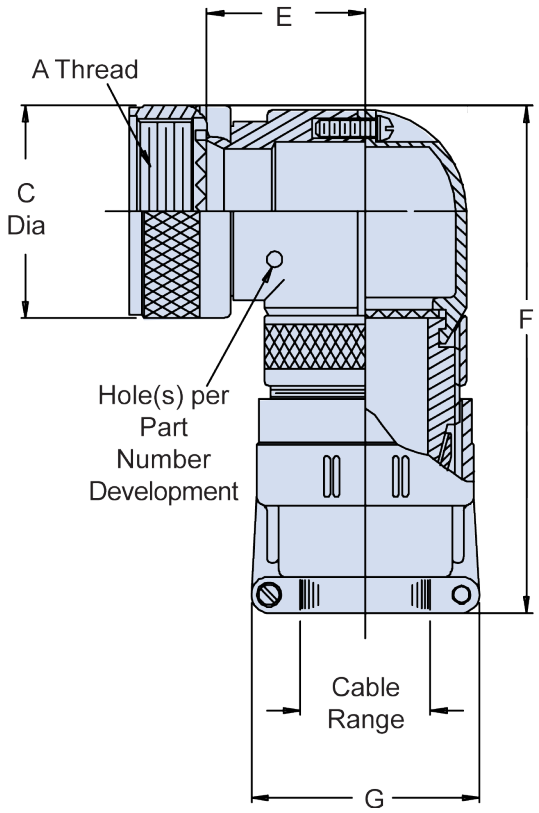

APPLICATION NOTES

- For complete dimensions see the applicable Military Specification.
- Metric dimensions (mm) are in parentheses.
- Cable Range is defined as the accommodation range for the wire bundle or cable. Dimensions shown are not intended for inspection criteria.

Dimensions in inches (millimeters) and are subject to change without notice.



AS85049/38 Straight Strain Relief Self-Locking or Non-Self-Locking

CONNECTOR DESIGNATOR:

H MIL-DTL-38999 Series III & IV
EN3645

**FOR NEW DESIGN
USE AS85049/124**

Basic
Part Number

M85049/38

Shell Size

S

11

W

S = Self-Locking
Use Dash for Non-Self-Locking
N = Non-Detented

Material and Finish Designator

A = Aluminum, Black Anodize
N = Aluminum, Electroless Nickel
S = 300 Series Steel, Passivated
W = Aluminum, 500 Hour Cadmium
Olive Drab over Electroless Nickel

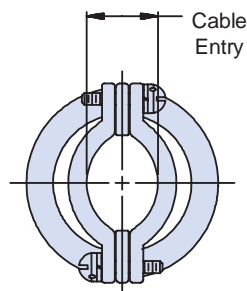
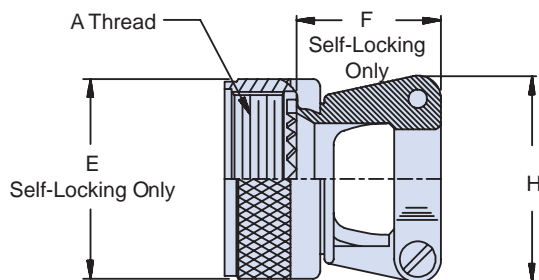

Note: Screw orientation shown is for non-self-locking configuration. Screws on self-locking configurations are on the same side/face of the clamp.

TABLE I: Shell Size, Cable Entry and Backshell Dimensions

Shell Size	Shell Size Ref.	A Thread Class 2B	Ø E Max		F Max		H Max		Cable Entry			
			Self-Locking Only	Self-Locking Only	Self-Locking Only	Self-Locking Only	Min	Max	Min	Max		
9	A	M12 X 1 - 6H	.858	(21.8)	.91	(23.1)	.85	(21.6)	.098	(2.5)	.234	(5.9)
11	B	M15 X 1 - 6H	.984	(25.0)	.91	(23.1)	.90	(22.9)	.153	(3.9)	.234	(5.9)
13	C	M18 X 1 - 6H	1.157	(29.4)	1.01	(25.7)	1.10	(27.9)	.190	(4.8)	.328	(8.3)
15	D	M22 X 1 - 6H	1.279	(32.5)	1.06	(26.9)	1.15	(29.2)	.260	(6.6)	.457	(11.6)
17	E	M25 X 1 - 6H	1.406	(35.7)	1.16	(29.5)	1.30	(33.0)	.283	(7.2)	.614	(15.6)
19	F	M28 X 1 - 6H	1.516	(38.5)	1.41	(35.8)	1.50	(38.1)	.325	(8.3)	.634	(16.1)
21	G	M31 X 1 - 6H	1.642	(41.7)	1.51	(38.4)	1.60	(40.6)	.343	(8.7)	.698	(17.7)
23	H	M34 X 1 - 6H	1.768	(44.9)	1.66	(42.2)	1.70	(43.2)	.381	(9.7)	.823	(20.9)
25	J	M37 X 1 - 6H	1.889	(48.0)	2.76	(44.7)	1.80	(45.7)	.418	(10.6)	.853	(21.7)

APPLICATION NOTES

1. Assembly to be identified with manufacturer's name and part number, space permitting.
2. Cable Entry is defined as the accommodation entry for the wire bundle or cable. Dimensions are not intended for inspection criteria.
3. For complete dimensions, see the applicable Military Specification.
4. Metric dimensions (mm) are in parentheses.

Dimensions in inches (millimeters) and are subject to change without notice.

AS85049/39
90° Strain Relief
Self-Locking or Non-Self-Locking



AS85049

CONNECTOR DESIGNATOR:	
H	MIL-DTL-38999 Series III & IV EN3645

FOR NEW DESIGN
USE AS85049/126

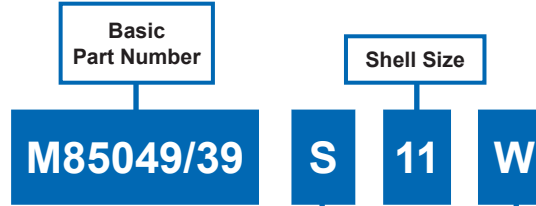

S = Self-Locking
Use Dash for Non-Self-Locking
N = Non-Detented

Material and Finish Designator
A = Aluminum, Black Anodize
N = Aluminum, Electroless Nickel
S = 300 Series Steel, Passivated
W = Aluminum, 500 Hour Cadmium Olive Drab over Electroless Nickel

B

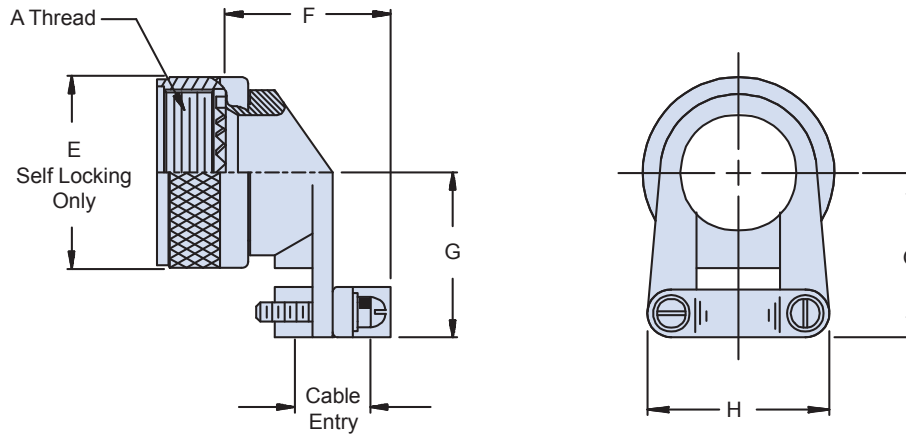

TABLE I: Shell Size, Cable Entry and Backshell Dimensions

Shell Size	Shell Size Ref.	A Thread Class 2B	Ø E Max		F Max		G Max		H Max		Cable Entry			
											Self-Locking Only		Min	Max
9	A	M12 X 1 - 6H	.858	(21.8)	1.01	(25.7)	1.00	(25.4)	.85	(21.6)	.098	(2.5)	.234	(5.9)
11	B	M15 X 1 - 6H	.984	(25.0)	1.01	(25.7)	1.10	(27.9)	.90	(22.9)	.153	(3.9)	.234	(5.9)
13	C	M18 X 1 - 6H	1.157	(29.4)	1.21	(30.7)	1.10	(27.9)	1.10	(27.9)	.190	(4.8)	.328	(8.3)
15	D	M22 X 1 - 6H	1.279	(32.5)	1.26	(32.0)	1.25	(31.8)	1.15	(29.2)	.260	(6.6)	.457	(11.6)
17	E	M25 X 1 - 6H	1.406	(35.7)	1.41	(35.8)	1.30	(33.0)	1.30	(33.0)	.283	(7.2)	.614	(15.6)
19	F	M28 X 1 - 6H	1.516	(38.5)	1.51	(38.4)	1.35	(34.3)	1.50	(38.1)	.325	(8.3)	.634	(16.1)
21	G	M31 X 1 - 6H	1.642	(41.7)	1.66	(42.2)	1.60	(40.6)	1.60	(40.6)	.343	(8.7)	.698	(17.7)
23	H	M34 X 1 - 6H	1.768	(44.9)	1.76	(44.7)	1.75	(44.5)	1.70	(43.2)	.381	(9.7)	.823	(20.9)
25	J	M37 X 1 - 6H	1.889	(48.0)	2.91	(73.9)	1.85	(47.0)	1.80	(45.7)	.418	(10.6)	.853	(21.7)

APPLICATION NOTES

1. Assembly to be identified with manufacturer's name and part number, space permitting.
2. Cable Entry is defined as the accommodation entry for the wire bundle or cable. Dimensions are not intended for inspection criteria.
3. For complete dimensions, see the applicable Military Specification.
4. Metric dimensions (mm) are in parentheses.

Dimensions in inches (millimeters) and are subject to change without notice.



AS85049/41 and MS3057A Straight Non-Self-Locking Strain Relief for Use with MS "V" Thread General Duty "A" End Bell

Basic
Part Number

Dash No.

M85049/41 - 3A

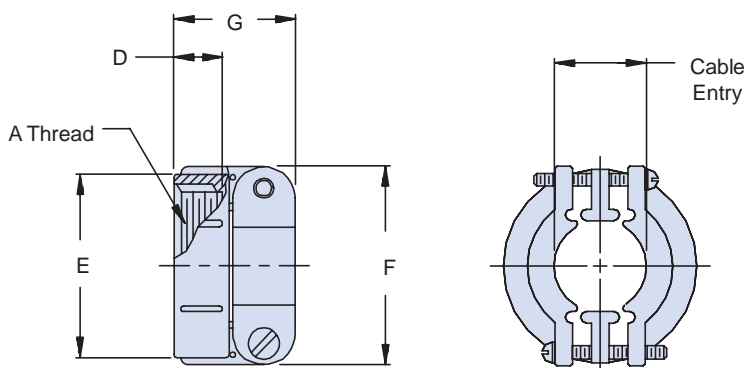

Superseded
Part Number

MS3057-16A

Basic
Part No.

Dash
No.

TABLE I: Shell Size, Cable Entry and Backshell Dimensions

Dash No.	Conn. Shell Ref.(s)	A Thread Class 2B	Cable Entry Max		D Ref.		Ø E		F		G	
							±.031	(0.8)	±.031	(0.8)	±.031	(0.8)
3A	8S, 10S	1/2 - 28 UNEF	.250	(6.4)	.406	(10.3)	.688	(17.5)	.812	(20.6)	.812	(20.6)
4A	10SL, 12S, 12	5/8 - 24 UNEF	.312	(7.9)	.406	(10.3)	.812	(20.6)	.875	(22.2)	.812	(20.6)
6A	14S, 14	3/4 - 20 UNEF	.438	(11.1)	.406	(10.3)	.969	(24.6)	1.062	(27.0)	.875	(22.2)
8A	16S, 16	7/8 - 20 UNEF	.562	(14.3)	.406	(10.3)	1.094	(27.8)	1.156	(29.4)	.938	(23.8)
10A	18	1 - 20 UNEF	.625	(15.9)	.406	(10.3)	1.188	(30.2)	1.250	(31.8)	.938	(23.8)
12A	20, 22	1 3/16 - 18 UNEF	.750	(19.1)	.406	(10.3)	1.375	(34.9)	1.469	(37.3)	.938	(23.8)
16A	24, 28	1 7/16 - 18 UNEF	.938	(23.8)	.406	(10.3)	1.656	(42.1)	1.688	(42.9)	1.031	(26.2)
20A	32	1 3/4 - 18 UNS	1.250	(31.8)	.469	(11.9)	2.031	(51.6)	2.031	(51.6)	1.094	(27.8)
24A	36	2 - 18 UNS	1.375	(34.9)	.531	(13.5)	2.219	(56.4)	2.281	(57.9)	1.156	(29.4)
28A	40	2 1/4 - 16 UN	1.625	(41.3)	.531	(13.5)	2.500	(63.5)	2.688	(68.3)	1.688	(42.9)
32A	44	2 1/2 - 16 UN	1.875	(47.6)	.594	(15.1)	2.781	(70.6)	2.938	(74.6)	1.750	(44.5)
40A	48	3 - 16 UN	2.375	(60.3)	.656	(16.7)	3.281	(83.3)	3.500	(88.9)	1.750	(44.5)

APPLICATION NOTES

1. Finish on M85049/41 is Cadmium Olive Drab over Electroless Nickel, 1,000 hour salt spray.
2. Assembly to be identified with manufacturer's name and part number, space permitting.
3. Cable Entry is defined as the accommodation entry for the wire bundle or cable. Dimensions are not intended for inspection criteria.
4. For complete dimensions, see the applicable Military Specification.
5. Metric dimensions (mm) are in parentheses.

Dimensions in inches (millimeters) and are subject to change without notice.

AS85049/42 and MS3057D
 Straight Non-Self-Locking Strain Relief
 for Use with MS "V" Thread General Duty "A" End Bell



AS85049

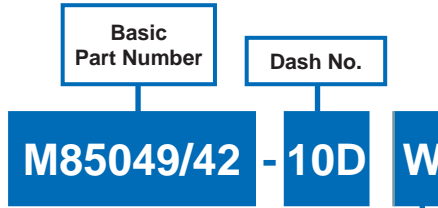

Superseded Part Number

MS3057 -10D A

Basic Part No. | Dash No. | Metal and Finish Designator

A = Aluminum Cadmium Olive Drab over Electroless Nickel
 C = Aluminum, Cadmium Olive Drab
 N = Aluminum, Electroless Nickel
 D = 300 Series Steel, Cadmium Black Plate
 S = 300 Series Steel, Passivate

Material/Finish

N = Aluminum/Electroless Nickel
W = Aluminum/1,000 Hour Cadmium over Electroless Nickel
X = Aluminum/Nickel Fluorocarbon Polymer
Y = Aluminum/Pure Dense Electrodeposited Aluminum
Z = Aluminum/Zinc Nickel Black
B = Stainless Steel/Cadmium Black
S = Stainless Steel/Passivated
XS = Stainless Steel/Nickel Fluorocarbon Polymer
YS = Stainless Steel/Pure Dense Electrodeposited Aluminum
ZS = Stainless Steel/Zinc Nickel Black

B

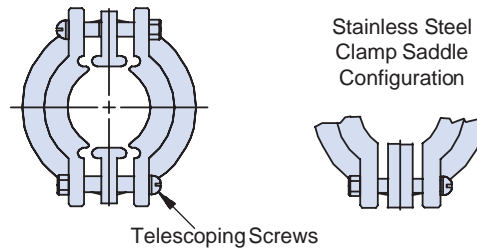
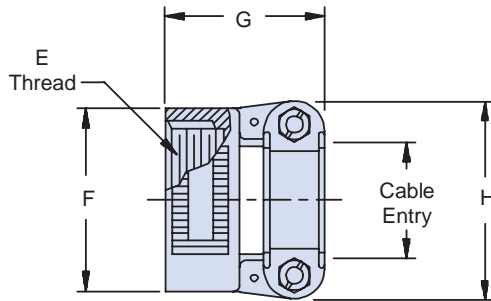

TABLE I: Shell Size, Cable Entry and Backshell Dimensions

Dash No.	E Thread Class 2B	Ø F Max	Ø G		H		Cable Entry				
			±.020	(.5)	±.020	(.5)	Max		Min		
4D	5/8 - 24 UNEF	.937 (23.8)	1.281 (32.5)	(32.5)	.937 (23.8)	.312 (7.9)	.125 (3.2)				
6D	3/4 - 20 UNEF	1.031 (26.2)	1.281 (32.5)	(32.5)	1.125 (28.6)	.437 (11.1)	.250 (6.4)				
8D	7/8 - 20 UNEF	1.250 (31.8)	1.281 (32.5)	(32.5)	1.312 (33.3)	.562 (14.3)	.312 (7.9)				
10D	1 - 20 UNEF	1.250 (31.8)	1.281 (32.5)	(32.5)	1.312 (33.3)	.625 (15.9)	.350 (8.9)				
12D	1 3/16 - 18 UNEF	1.437 (36.5)	1.312 (33.3)	(33.3)	1.531 (38.9)	.750 (19.1)	.500 (12.7)				
16D	1 7/16 - 18 UNEF	1.688 (42.9)	1.406 (35.7)	(35.7)	1.750 (44.5)	.937 (23.8)	.625 (15.9)				
20D	1 3/4 - 18 UNS	2.000 (50.8)	1.563 (39.7)	(39.7)	2.093 (53.2)	1.250 (31.8)	.875 (22.2)				
24D	2 - 18 UNS	2.250 (57.2)	1.625 (41.3)	(41.3)	2.343 (59.5)	1.375 (34.9)	1.000 (25.4)				
28D	2 1/4 - 16 UN	2.500 (63.5)	1.900 (48.3)	(48.3)	2.750 (69.9)	1.625 (41.3)	1.250 (31.8)				
32D	2 1/2 - 16 UN	2.750 (69.9)	1.900 (48.3)	(48.3)	3.000 (76.2)	1.875 (47.6)	1.437 (36.5)				

- APPLICATION NOTES**
1. Assembly to be identified with manufacturer's name and part number, space permitting.
 2. Cable Entry is defined as the accommodation entry for the wire bundle or cable. Dimensions are not intended for inspection criteria.
 3. For complete dimensions, see the applicable Military Specification.
 4. Metric dimensions (mm) are in parentheses.

Dimensions in inches (millimeters) and are subject to change without notice.



AS85049/43 and MS3415 Strain Relief 45° Self-Locking or Non-Self-Locking

CONNECTOR DESIGNATOR:

A

AS5015 Series AS34001 Crimp,
MIL-DTL-26482 Series II,
AS81703 Crimp Series III,
MIL-DTL-83723 Series I & III

Basic
Part Number

M85049/43

Dash No.

S

10

W

S = Self-Locking
Use Dash for Non-Self-Locking
N = Non-Detented

Finish

A = Anodize, Black
N = Electroless Nickel
W = 1,000 Hour Cadmium Olive Drab
over Electroless Nickel
X = Nickel Fluorocarbon Polymer
Y = Pure Dense Electrodeposited
Aluminum
Z = Zinc-Nickel, Black

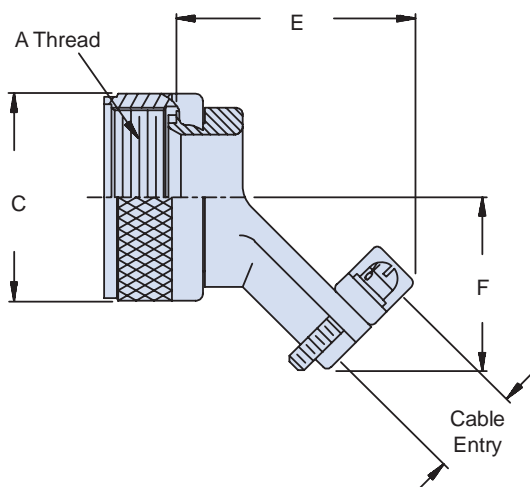

TABLE I: Shell Size, Cable Entry and Backshell Dimensions

Dash No.	A Thread Class 2B	C Max	E Closed		F Max		Cable Entry			
							Min	Max	Min	Max
3*	.562 - 24 UNEF	.669 (17.0)	1.160 (29.5)	.772 (19.6)	.125 (3.2)	.204 (5.2)	.125 (3.2)	.204 (5.2)	.204 (5.2)	.204 (5.2)
8	.500 - 20 UNF	.885 (22.5)	1.650 (29.5)	.772 (19.6)	.125 (3.2)	.204 (5.2)	.125 (3.2)	.204 (5.2)	.204 (5.2)	.204 (5.2)
10	.625 - 24 UNEF	1.010 (25.7)	1.694 (30.6)	.803 (20.4)	.187 (4.7)	.286 (7.3)	.187 (4.7)	.286 (7.3)	.286 (7.3)	.286 (7.3)
12	.750 - 20 UNEF	1.135 (28.8)	1.768 (32.5)	.866 (22.0)	.291 (7.4)	.416 (10.6)	.291 (7.4)	.416 (10.6)	.416 (10.6)	.416 (10.6)
14	.875 - 20 UNEF	1.260 (32.0)	1.840 (33.5)	.928 (23.6)	.351 (8.9)	.476 (12.1)	.351 (8.9)	.476 (12.1)	.476 (12.1)	.476 (12.1)
16	1.000 - 20 UNEF	1.385 (35.2)	1.916 (36.2)	.991 (25.2)	.501 (12.7)	.625 (15.9)	.501 (12.7)	.625 (15.9)	.625 (15.9)	.625 (15.9)
18	1.062 - 18 UNEF	1.570 (39.9)	2.034 (39.2)	1.110 (28.2)	.518 (13.2)	.706 (17.9)	.518 (13.2)	.706 (17.9)	.706 (17.9)	.706 (17.9)
20	1.188 - 18 UNEF	1.635 (41.5)	2.078 (40.3)	1.172 (29.8)	.581 (14.8)	.831 (21.1)	.581 (14.8)	.831 (21.1)	.831 (21.1)	.831 (21.1)
22	1.313 - 18 UNEF	1.760 (44.7)	2.122 (41.5)	1.235 (31.4)	.644 (16.4)	.956 (24.3)	.644 (16.4)	.956 (24.3)	.956 (24.3)	.956 (24.3)
24	1.438 - 18 UNEF	1.885 (47.9)	2.166 (42.6)	1.297 (32.9)	.706 (17.9)	1.081 (27.5)	.706 (17.9)	1.081 (27.5)	1.081 (27.5)	1.081 (27.5)
28	1.750 - 18 UNS	2.135 (54.2)	2.461 (45.7)	1.543 (39.2)	.750 (19.1)	1.187 (30.1)	.750 (19.1)	1.187 (30.1)	1.187 (30.1)	1.187 (30.1)
32	2.000 - 18 UNS	2.315 (58.8)	2.549 (48.0)	1.668 (42.4)	.875 (22.2)	1.250 (31.8)	.875 (22.2)	1.250 (31.8)	1.250 (31.8)	1.250 (31.8)
36	2.250 - 16 UN	2.635 (66.9)	2.595 (49.1)	1.793 (45.5)	.938 (23.8)	1.375 (34.9)	.938 (23.8)	1.375 (34.9)	1.375 (34.9)	1.375 (34.9)
40	2.500 - 16 UN	2.885 (73.3)	2.599 (49.1)	1.918 (48.7)	.938 (23.8)	1.500 (38.1)	.938 (23.8)	1.500 (38.1)	1.500 (38.1)	1.500 (38.1)
44	2.750 - 16 UN	3.135 (79.6)	2.860 (55.9)	2.132 (54.2)	1.188 (30.2)	1.750 (44.5)	1.188 (30.2)	1.750 (44.5)	1.750 (44.5)	1.750 (44.5)
48	3.000 - 16 UN	3.385 (86.0)	2.918 (58.1)	2.257 (57.3)	1.312 (33.3)	1.875 (47.6)	1.312 (33.3)	1.875 (47.6)	1.875 (47.6)	1.875 (47.6)
61*	1.500 - 18 UNEF	1.653 (41.5)	1.676 (42.6)	1.204 (30.6)	.706 (17.9)	1.081 (27.5)	.706 (17.9)	1.081 (27.5)	1.081 (27.5)	1.081 (27.5)

* See Note 5

APPLICATION NOTES

1. Assembly to be identified with manufacturer's name and part number, space permitting.
2. Cable Entry is defined as the accommodation entry for the wire bundle or cable. Dimensions are not intended for inspection criteria.
3. For complete dimensions, see the applicable Military Specification.
4. Metric dimensions (mm) are in parentheses.
5. Non-Self-Locking only.

Dimensions in inches (millimeters) and are subject to change without notice.

AS85049/44 and M83733/16 Straight Non-Self-Locking Strain Relief



AS85049

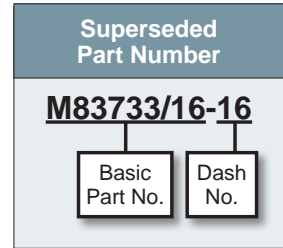
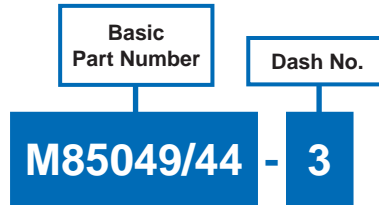

B

- ### APPLICATION NOTES
1. Assembly to be identified with manufacturer's name and part number, space permitting.
 2. Maximum dimension with halves bottomed.
 3. For complete dimensions, see the applicable Military Specification.
 4. Metric dimensions (mm) are in parentheses.
 5. Material/Finish:
Frame and saddles - Aluminum alloy/Electroless nickel
Hardware - CRES/Passivated
Saddle cushion - Silicone/N/A

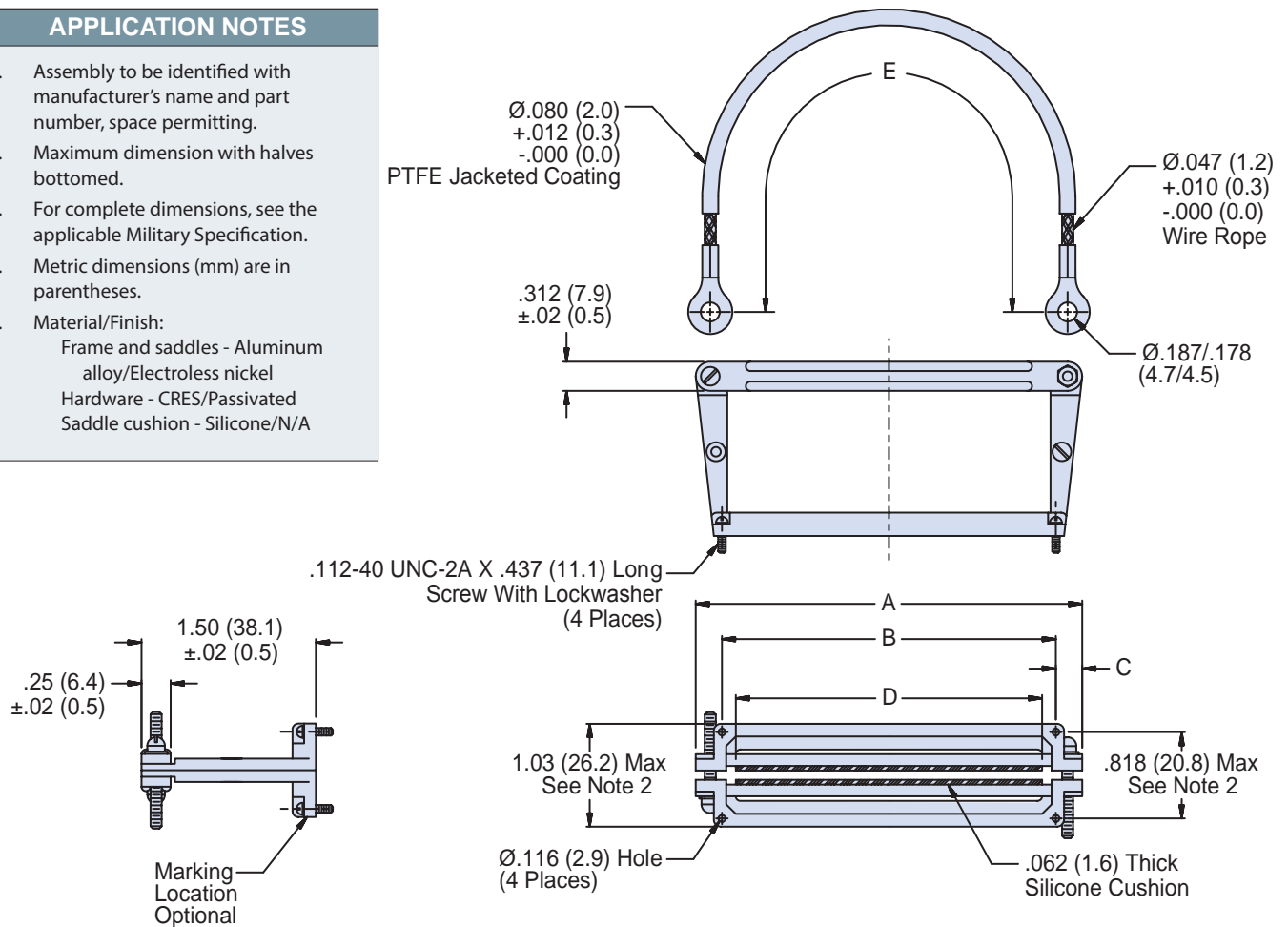

TABLE I: Dash Number, Shell Size and Dimensions

Dash No.	Shell Size	A Dim ± .062 (1.6)	B Dim ± .005 (0.1)	C Dim ± .032 (0.8)	D Dim ± .062 (1.6)	E Dim ± .062 (1.6)	Lanyard
1	A	2.437 (61.9)	1.895 (48.1)	.271 (6.9)	1.70 (43.2)	N/A	Without
2	B	3.750 (95.3)	3.195 (81.2)	.277 (7.0)	3.00 (76.2)	N/A	
3	A	2.437 (61.9)	1.895 (48.1)	.271 (6.9)	1.70 (43.2)	10.375 (263.5)	With
4	B	3.750 (95.3)	3.195 (81.2)	.277 (7.0)	3.00 (76.2)	10.375 (263.5)	

Dimensions in inches (millimeters) and are subject to change without notice.

AS85049/45 and MS27663-1 Straight Composite Non-Self-Locking Strain Relief

CONNECTOR DESIGNATOR:
F MIL-DTL-38999 Series I and II

**Basic
Part Number**
M85049/45
Dash No.
W
10
**Superseded
Part Number**
MS27663-1
**Basic
Part No.**
**Dash
No.**
Finish

A = Anodize, Black
W = 1,000 Hour Cadmium Olive Drab
 over Electroless Nickel
X = Nickel Fluorocarbon Polymer
Y = Pure Dense Electrodeposited
 Aluminum
Z = Zinc-Nickel, Black

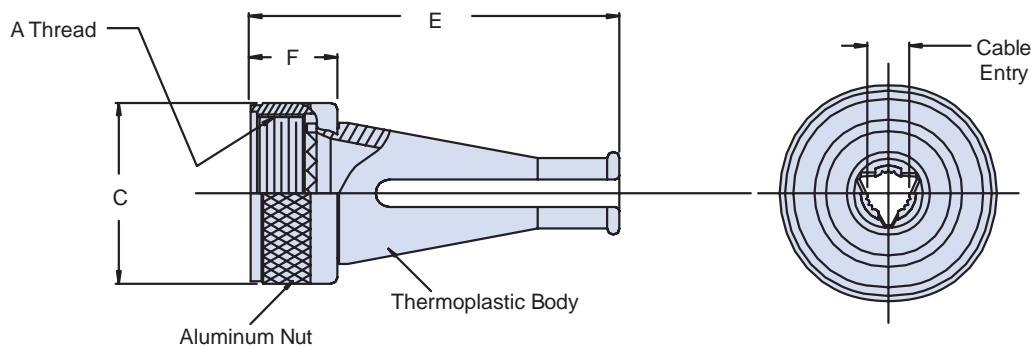
TABLE I: Shell Size, Cable Entry and Backshell Dimensions

Dash No.	Shell Size Ref.	A Thread Class 2B	Ø C Max	E Max		F Max		Cable Entry			
								Min		Max	
8	8/9	.438 - 28 UNEF	.578 (14.7)	1.344 (34.1)	.422 (10.7)	.094 (2.4)	.203 (5.2)				
10	10/11	.562 - 24 UNEF	.703 (17.9)	1.344 (34.1)	.422 (10.7)	.141 (3.6)	.250 (6.4)				
12	12/13	.688 - 24 UNEF	.828 (21.0)	1.344 (34.1)	.422 (10.7)	.172 (4.4)	.323 (8.2)				
14	14/15	.813 - 20 UNEF	.953 (24.2)	1.344 (34.1)	.422 (10.7)	.203 (5.2)	.422 (10.7)				
16	16/17	.938 - 20 UNEF	1.078 (27.4)	1.344 (34.1)	.422 (10.7)	.234 (5.9)	.500 (12.7)				
18	18/19	1.063 - 18 UNEF	1.203 (30.6)	1.344 (34.1)	.422 (10.7)	.265 (6.7)	.562 (14.3)				
20	20/21	1.188 - 18 UNEF	1.328 (33.7)	1.422 (36.1)	.422 (10.7)	.297 (7.5)	.625 (15.9)				
22	22/23	1.313 - 18 UNEF	1.453 (36.9)	1.422 (36.1)	.422 (10.7)	.328 (8.3)	.703 (17.9)				
24	24/25	1.438 - 18 UNEF	1.578 (40.1)	1.422 (36.1)	.344 (8.7)	.359 (9.1)	.765 (19.4)				

APPLICATION NOTES

1. Assembly to be identified with manufacturer's name and part number, space permitting.
2. Cable Entry is defined as the accommodation entry for the wire bundle or cable. Dimensions are not intended for inspection criteria.
3. For complete dimensions, see the applicable Military Specification.
4. Metric dimensions (mm) are in parentheses.

Dimensions in inches (millimeters) and are subject to change without notice.

AS85049/46 and MS27663-2 90° Non-Self-Locking Composite Strain Relief



AS85049

B

CONNECTOR DESIGNATOR:	
F	MIL-DTL-38999 Series I and II

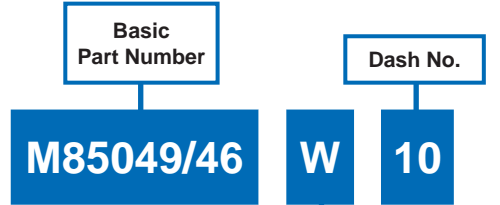

Finish	
<i>A</i>	Anodize, Black
<i>W</i>	1,000 Hour Cadmium Olive Drab over Electroless Nickel
<i>X</i>	Nickel Fluorocarbon Polymer
<i>Y</i>	Pure Dense Electrodeposited Aluminum
<i>Z</i>	Zinc-Nickel, Black

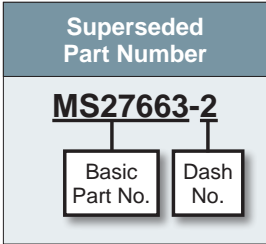
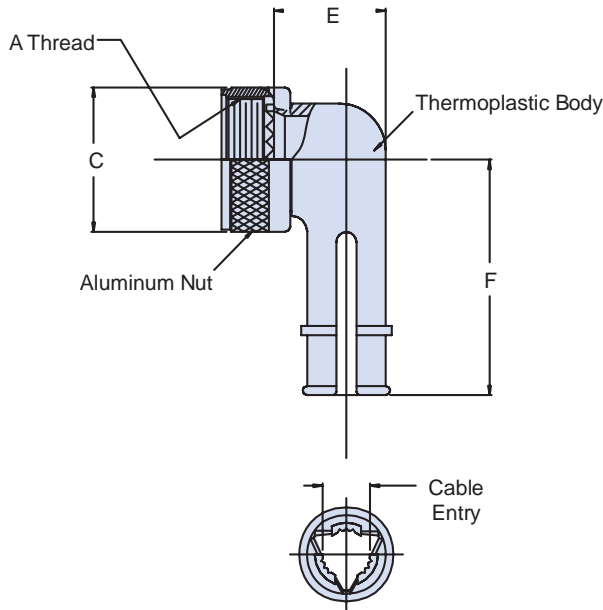

TABLE I: Shell Size, Cable Entry and Backshell Dimensions

Dash No.	Shell Size Ref.	A Thread Class 2B	Ø C Max	E Max	F Max	Cable Entry			
						Min	Max	Min	Max
8	8/9	.438 - 28 UNEF	.578 (14.7)	.656 (16.7)	1.015 (25.8)	.094 (2.4)	.203 (5.2)		
10	10/11	.562 - 24 UNEF	.703 (17.9)	.688 (17.5)	1.062 (27.0)	.141 (3.6)	.250 (6.4)		
12	12/13	.688 - 24 UNEF	.828 (21.0)	.750 (19.1)	1.125 (28.6)	.172 (4.4)	.323 (8.2)		
14	14/15	.813 - 20 UNEF	.953 (24.2)	.859 (21.8)	1.328 (33.7)	.203 (5.2)	.422 (10.7)		
16	16/17	.938 - 20 UNEF	1.078 (27.4)	.937 (23.8)	1.392 (35.4)	.234 (5.9)	.500 (12.7)		
18	18/19	1.063 - 18 UNEF	1.203 (30.6)	1.000 (25.4)	1.453 (36.9)	.265 (6.7)	.562 (14.3)		
20	20/21	1.188 - 18 UNEF	1.328 (33.7)	1.062 (27.0)	1.609 (40.9)	.297 (7.5)	.625 (15.9)		
22	22/23	1.313 - 18 UNEF	1.453 (36.9)	1.141 (29.0)	1.656 (42.1)	.328 (8.3)	.703 (17.9)		
24	24/25	1.438 - 18 UNEF	1.578 (40.1)	1.203 (30.6)	1.719 (43.7)	.359 (9.1)	.765 (19.4)		

APPLICATION NOTES

1. Assembly to be identified with manufacturer's name and part number, space permitting.
2. Cable Entry is defined as the accommodation entry for the wire bundle or cable. Dimensions are not intended for inspection criteria.
3. For complete dimensions, see the applicable Military Specification.
4. Metric dimensions (mm) are in parentheses.

Dimensions in inches (millimeters) and are subject to change without notice.



AS85049/47 and MS27507 90° Strain Relief Self-Locking or Non-Self-Locking

CONNECTOR DESIGNATOR:

F MIL-DTL-38999 Series I and II

**FOR NEW DESIGN
USE AS85049/123**

**Basic
Part Number**

M85049/47

Material and Finish Designator

N = Aluminum, Electroless Nickel
S = 300 Series Steel, Passivated
W = Aluminum, 1000 Hour Cadmium
Olive Drab over Electroless Nickel

S

W

10

S = Self-Locking
Omit for Non-Self-Locking
N = Non-Detented, Self-Locking

Dash No.

Superseded Part Number

MS27507-B 10

**Basic Part No.
(Non-Self-
Locking)**

Dash No.

Metal and Finish Designator

A = Aluminum Cadmium Olive Drab over Electroless Nickel
C = Aluminum, Cadmium Olive Drab
N = Aluminum, Electroless Nickel
D = 300 Series Steel, Cadmium Black Plate
S = 300 Series Steel, Passivate

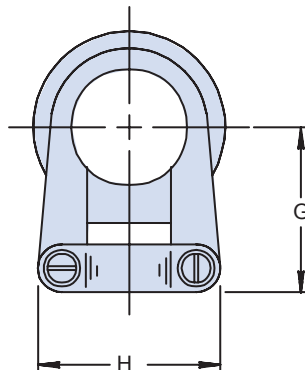
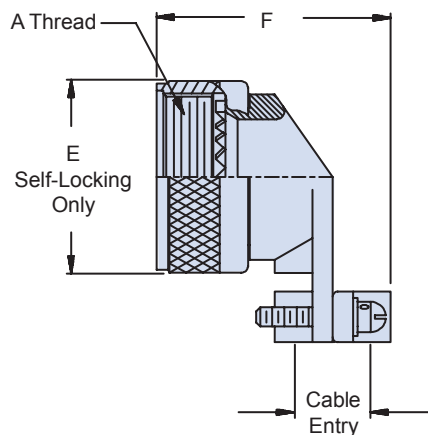

APPLICATION NOTES

1. Assembly to be identified with manufacturer's name and part number, space permitting.
2. Cable Entry is defined as the accommodation entry for the wire bundle or cable.
3. Dimensions are not intended for inspection criteria.
4. For complete dimensions, see the applicable Military Specification.
5. Metric dimensions (mm) are in parentheses.

TABLE I: Shell Size, Cable Entry and Backshell Dimensions

Dash No.	Shell Size Ref.	A Thread Class 2B	Ø E Max		F Max		G Max		H Max		Cable Entry			
											Min	Max		
8	8/9	.438 - 28 UNEF	.86	(21.8)	1.38	(35.1)	1.00	(25.4)	.85	(21.6)	.098	(2.5)	.234	(5.9)
10	10/11	.562 - 24 UNEF	.98	(24.9)	1.38	(35.1)	1.10	(27.9)	.90	(22.9)	.153	(3.9)	.234	(5.9)
12	12/13	.688 - 24 UNEF	1.16	(29.5)	1.46	(37.1)	1.10	(27.9)	1.10	(27.9)	.190	(4.8)	.328	(8.3)
14	14/15	.813 - 20 UNEF	1.28	(32.5)	1.63	(41.4)	1.25	(31.8)	1.15	(29.2)	.260	(6.6)	.457	(11.6)
16	16/17	.938 - 20 UNEF	1.41	(35.8)	1.80	(45.7)	1.30	(33.0)	1.30	(33.0)	.283	(7.2)	.614	(15.6)
18	18/19	1.063 - 18 UNEF	1.52	(38.6)	1.82	(46.2)	1.35	(34.3)	1.50	(38.1)	.325	(8.3)	.634	(16.1)
20	20/21	1.188 - 18 UNEF	1.64	(41.7)	1.90	(48.3)	1.60	(40.6)	1.60	(40.6)	.343	(8.7)	.698	(17.7)
22	22/23	1.313 - 18 UNEF	1.77	(45.0)	2.04	(51.8)	1.75	(44.5)	1.70	(43.2)	.381	(9.7)	.823	(20.9)
24	24/25	1.438 - 18 UNEF	1.89	(48.0)	2.15	(54.6)	1.85	(47.0)	1.80	(45.7)	.418	(10.6)	.853	(21.7)

Dimensions in inches (millimeters) and are subject to change without notice.

AS85049/48-1
Rectangular Backshells
MIL-DTL-24308



AS85049

B

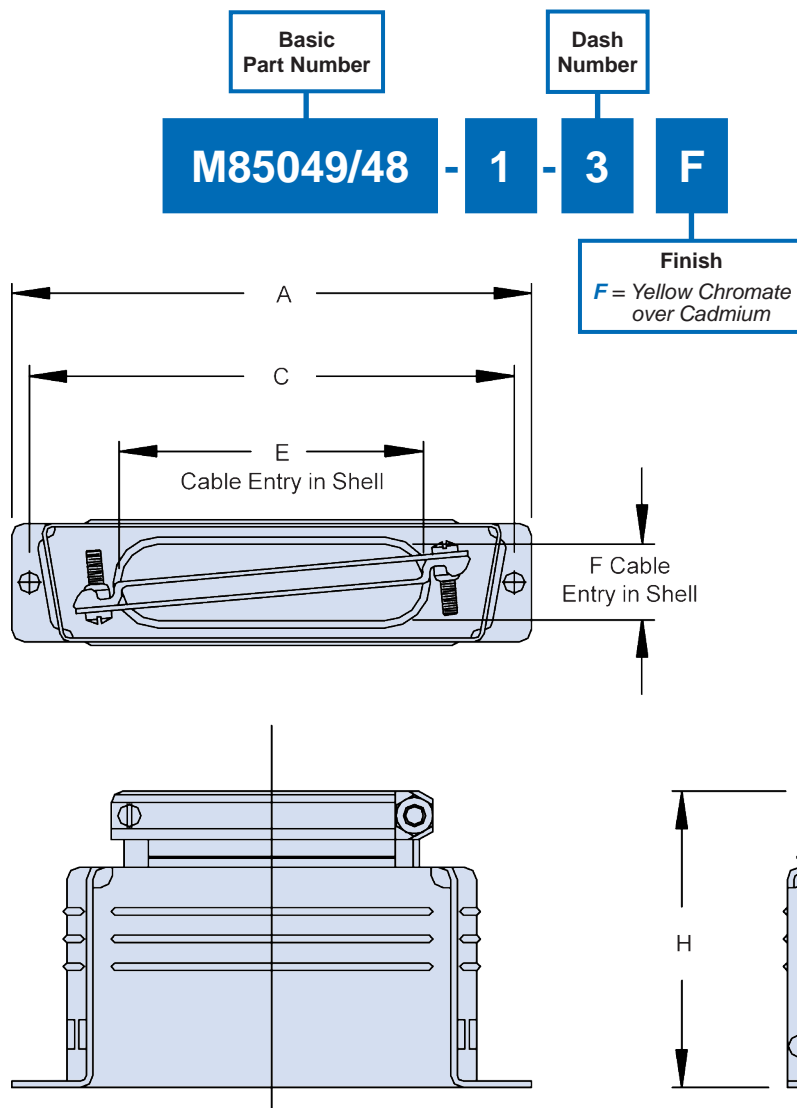

TABLE I: Dash Number and Backshell Dimensions

Dash No.	A ± .015 (0.4)	C ± .005 (.13)	E ± .015 (0.4)	F ± .015 (0.4)	G ± .015 (0.4)	H Max
1	1.203 (30.6)	.984 (25.0)	.375 (9.5)	.375 (9.5)	.750 (19.1)	1.250 (31.8)
2	1.531 (38.9)	1.312 (33.3)	.713 (18.1)	.312 (7.9)	.750 (19.1)	1.250 (31.8)
3	2.078 (52.8)	1.852 (47.0)	1.000 (25.4)	.312 (7.9)	1.000 (25.4)	1.563 (39.7)
4	2.718 (69.0)	2.500 (63.5)	1.375 (34.9)	.312 (7.9)	1.000 (25.4)	1.563 (39.7)
5	2.625 (66.7)	2.406 (61.1)	1.406 (35.7)	.406 (10.3)	1.125 (28.6)	1.688 (42.9)

APPLICATION NOTES

1. Assembly identified with manufacturer's name and part number, space permitting.
2. For complete dimensions, see the applicable Military Specification.
3. Metric dimensions (mm) are in parentheses.

Dimensions in inches (millimeters) and are subject to change without notice.

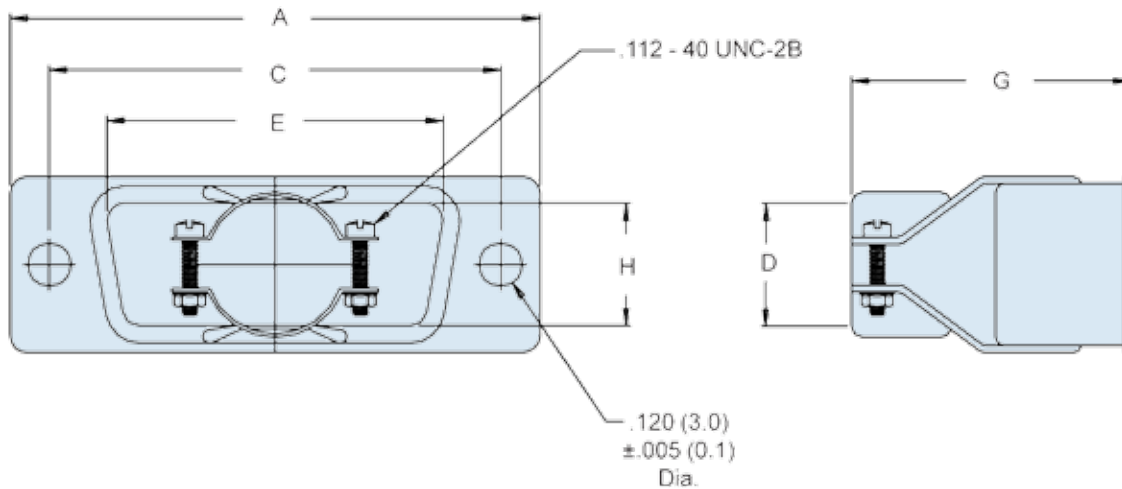
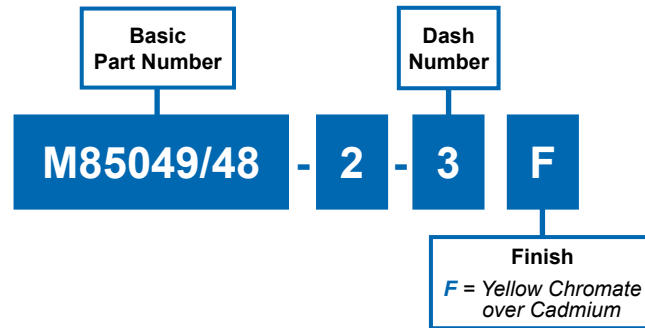
APPLICATION NOTES

1. Assembly identified with manufacturer's name and part number, space permitting.
2. For complete dimensions, see the applicable Military Specification.
3. Metric dimensions (mm) are in parentheses.

TABLE I: Dash Number and Backshell Dimensions

Dash No.	Nonmagnetic (Brass)	A ± .015 (0.4)	C ± .005 (.13)	D	E ± .015 (0.4)	G ± .030 (0.8)	H ± .015 (0.4)
1	6	1.208 (30.7)	.984 (25.0)	.406 (10.3)	.661 (16.8)	1.031 (26.2)	.344 (8.7)
2	7	1.531 (38.9)	1.312 (33.3)	.406 (10.3)	.984 (25.0)	1.031 (26.2)	.344 (8.7)
3	8	2.078 (52.8)	1.852 (47.0)	.593 (15.1)	1.515 (38.5)	1.062 (27.0)	.344 (8.7)
4	9	2.718 (69.0)	2.500 (63.5)	.718 (18.2)	2.171 (55.1)	1.062 (27.0)	.344 (8.7)
5	10	2.625 (66.7)	2.406 (61.1)	.812 (20.6)	2.093 (53.2)	1.062 (27.0)	.438 (11.1)

Dimensions in inches (millimeters) and are subject to change without notice.

AS85049/48-3
Rectangular Backshell
MIL-DTL-24308



AS85049

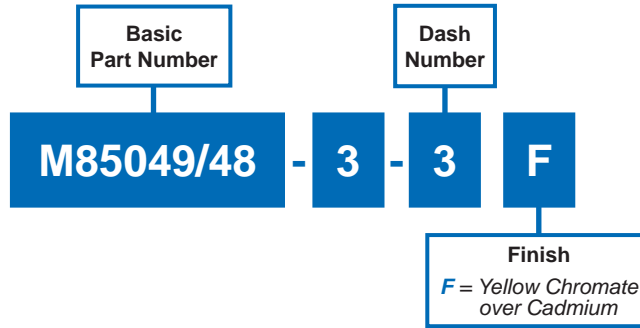

B

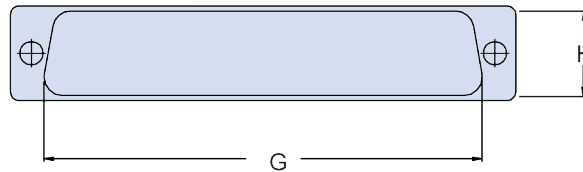
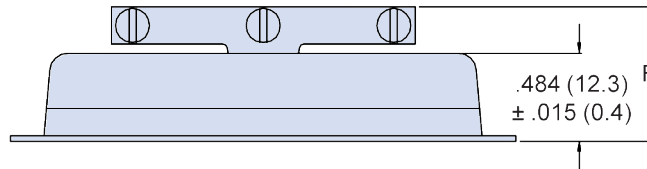
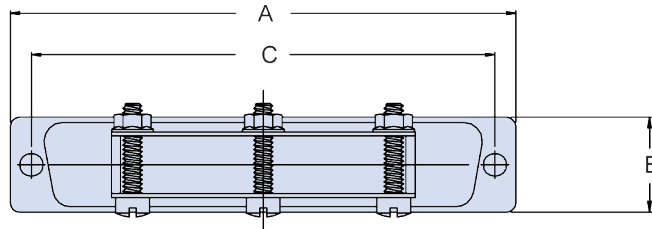

TABLE I: Dash Number and Backshell Dimensions

Dash No.	No. of Screws	A ± .015 (0.4)	B ± .015 (0.4)	C ± .005 (0.1)	F Max	G ± .015 (0.4)	H ± .015 (0.4)
2	2	1.531 (38.9)	.500 (12.7)	1.312 (33.3)	.679 (17.2)	1.091 (27.7)	.442 (11.2)
3	2	2.078 (52.8)	.500 (12.7)	1.852 (47.0)	.679 (17.2)	1.631 (41.4)	.442 (11.2)
4	3	2.718 (69.0)	.500 (12.7)	2.500 (63.5)	.679 (17.2)	2.282 (58.0)	.442 (11.2)
5	3	2.625 (66.7)	.609 (15.5)	2.406 (61.1)	.724 (18.4)	2.205 (56.0)	.565 (14.4)

APPLICATION NOTES

1. Assembly identified with manufacturer's name and part number, space permitting.
2. For complete dimensions, see the applicable Military Specification.
3. Metric dimensions (mm) are in parentheses.

Dimensions in inches (millimeters) and are subject to change without notice.



AS85049/49-2 and MS27506

Straight Strain Relief

Self-Locking or Non-Self-Locking

CONNECTOR DESIGNATOR:

F MIL-DTL-27599,
MIL-DTL-38999 Series I & II

**FOR NEW DESIGN
USE AS85049/121**

Basic
Part Number

M85049/49-2

Dash No.

S

10

W

S = Self-Locking
Use Dash for Non-Self-Locking
N = Non-Detented

Material and Finish Designator

A = Aluminum, Black Anodize
N = Aluminum, Electroless Nickel
S = 300 Series Steel, Passivated
W = Aluminum, 1000 Hour Cadmium
Olive Drab over Electroless Nickel

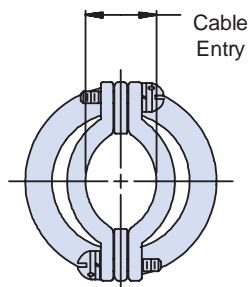
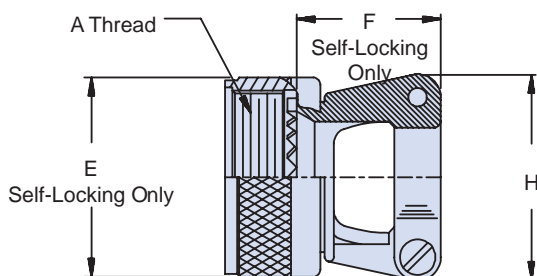

Note: Screw orientation shown is for non-self-locking configuration. Screws on self-locking configurations are on the same side/face of the clamp.

TABLE I: Shell Size, Cable Entry and Backshell Dimensions

Shell Size	Shell Size Ref.	A Thread Class 2B	Ø E Max		F Max		H Max		Cable Entry			
			Self-Locking Only		Self-Locking Only				Min	Max		
8	8/9	.438 - 28 UNEF	.86	(21.8)	.91	(23.1)	.85	(21.6)	.098	(2.5)	.234	(5.9)
10	10/11	.562 - 24 UNEF	.98	(24.9)	.91	(23.1)	.90	(22.9)	.153	(3.9)	.234	(5.9)
12	12/13	.688 - 24 UNEF	1.16	(29.5)	1.01	(25.7)	1.10	(27.9)	.190	(4.8)	.328	(8.3)
14	14/15	.813 - 20 UNEF	1.28	(32.5)	1.06	(26.9)	1.15	(29.2)	.260	(6.6)	.457	(11.6)
16	16/17	.938 - 20 UNEF	1.41	(35.8)	1.16	(29.5)	1.30	(33.0)	.283	(7.2)	.614	(15.6)
18	18/19	1.063 - 18 UNEF	1.52	(38.6)	1.41	(35.8)	1.50	(38.1)	.325	(8.3)	.634	(16.1)
20	20/21	1.188 - 18 UNEF	1.64	(41.7)	1.51	(38.4)	1.60	(40.6)	.343	(8.7)	.698	(17.7)
22	22/23	1.313 - 18 UNEF	1.77	(45.0)	1.66	(42.2)	1.70	(43.2)	.381	(9.7)	.823	(20.9)
24	24/25	1.438 - 18 UNEF	1.89	(48.0)	1.76	(44.7)	1.80	(45.7)	.418	(10.6)	.853	(21.7)

APPLICATION NOTES

1. Assembly to be identified with manufacturer's name and part number, space permitting.
2. Cable Entry is defined as the accommodation entry for the wire bundle or cable. Dimensions are not intended for inspection criteria.
3. For complete dimensions, see the applicable Military Specification.
4. Metric dimensions (mm) are in parentheses.

Dimensions in inches (millimeters) and are subject to change without notice.

AS85049/50
Rectangular Backshell
MIL-DTL-24308



AS85049

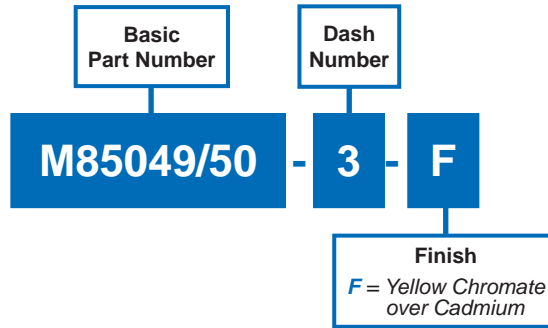

B

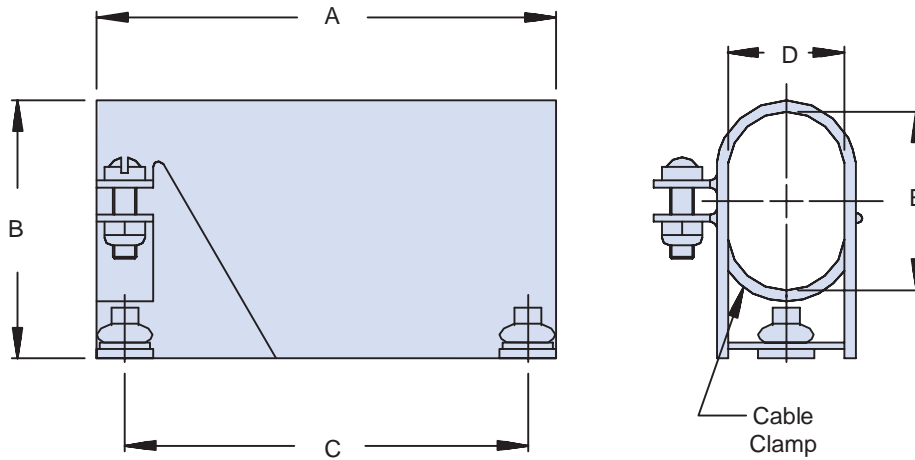

TABLE I: Dash Number and Backshell Dimensions

Dash No.	A ± .015 (0.4)	B ± .030 (0.8)	C ± .005 (0.1)	D Max	E .030 (0.8)
1	1.203 (30.6)	.718 (18.2)	.984 (25.0)	.467 (11.9)	.437 (11.1)
2	1.531 (38.9)	.718 (18.2)	1.312 (33.3)	.467 (11.9)	.437 (11.1)
3	2.078 (52.8)	.968 (24.6)	1.852 (47.0)	.467 (11.9)	.625 (15.9)
4	2.718 (69.0)	1.187 (30.1)	2.500 (63.5)	.467 (11.9)	.812 (20.6)
5	2.625 (66.7)	1.250 (31.8)	2.406 (61.1)	.592 (15.0)	.906 (23.0)

- APPLICATION NOTES**
1. Assembly identified with manufacturer's name and part number, space permitting.
 2. For complete dimensions, see the applicable Military Specification.
 3. Metric dimensions (mm) are in parentheses.

Dimensions in inches (millimeters) and are subject to change without notice.



AS85049/51 and MS3418

90° Strain Relief

Self-Locking or Non-Self-Locking

CONNECTOR DESIGNATOR:

A

AS50151 Series AS34001 Crimp,
MIL-DTL-26482 Series II,
SAE-AS1703 Crimp Series III,
MIL-DTL-83723 Series I & III

Basic
Part Number

M85049/51

Dash No.

S

10

W

FOR NEW DESIGN
USE AS85049/120

Superseded Part Number

MS3418-10 C

Basic
Part No.
(Non-Self-
Locking)

Dash
No.

Metal and Finish Designator
A = Aluminum 1000 Hour Cadmium Olive
Drab over Electroless Nickel
C = Aluminum, Cadmium Olive Drab
G = Aluminum Black Anodize
N = Aluminum, Electroless Nickel

S = Self-Locking
-1 = Non-Self-Locking
N = Non-Detented

Material and Finish Designator
A = Aluminum, Black Anodize
N = Aluminum, Electroless Nickel
S = Stainless Steel, Passivate
W = Aluminum, 1000 Hr. Cadmium O.D.
over Electroless Nickel

APPLICATION NOTES

1. Assembly to be identified with manufacturer's name and part number, space permitting.
2. Cable Entry is defined as the accommodation entry for the wire bundle or cable.
3. Dimensions are not intended for inspection criteria.
4. For complete dimensions, see the applicable Military Specification.
5. Metric dimensions (mm) are in parentheses.

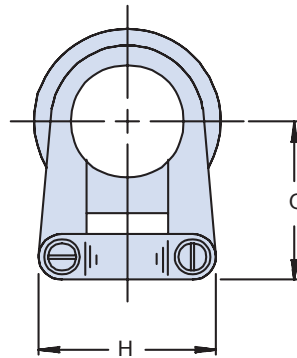
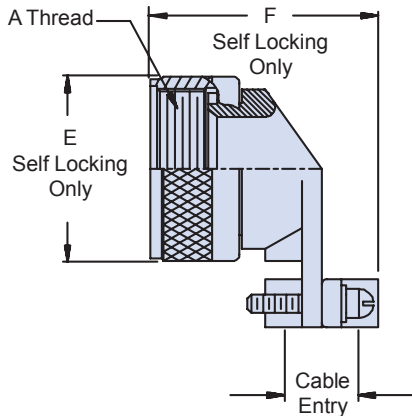

TABLE I: Shell Size, Cable Entry and Backshell Dimensions

Dash No.	A Thread Class 2B	Ø E Max		F Max		G		H Max	Cable Entry				
		Self-Locking		Self-Locking		±.062	(1.6)		Min	Max			
3*+	.562 - 24 UNEF	-	-	-	-	.777	(19.7)	.782	(19.9)	.125	(3.2)	.204	(5.2)
8	.500 - 20 UNF	.885	(22.5)	1.257	(31.9)	.746	(18.9)	.782	(19.9)	.125	(3.2)	.204	(5.2)
10	.625 - 24 UNEF	1.010	(25.7)	1.339	(34.0)	.805	(20.4)	.862	(21.9)	.187	(4.7)	.286	(7.3)
12	.750 - 20 UNEF	1.135	(28.8)	1.532	(38.9)	.867	(22.0)	1.003	(25.5)	.291	(7.4)	.416	(10.6)
14	.875 - 20 UNEF	1.260	(32.0)	1.592	(40.4)	.930	(23.6)	1.061	(26.9)	.351	(8.9)	.476	(12.1)
16	1.000 - 20 UNEF	1.385	(35.2)	1.741	(44.2)	.994	(25.2)	1.334	(33.9)	.501	(12.7)	.626	(15.9)
18	1.062 - 18 UNEF	1.510	(38.4)	1.853	(47.1)	1.171	(29.7)	1.466	(37.2)	.518	(13.2)	.706	(17.9)
20	1.188 - 18 UNEF	1.635	(41.5)	1.978	(50.2)	1.234	(31.2)	1.572	(39.9)	.581	(14.8)	.831	(21.1)
22	1.313 - 18 UNEF	1.760	(44.7)	2.108	(53.5)	1.296	(32.9)	1.688	(42.9)	.644	(16.4)	.956	(24.3)
24	1.438 - 18 UNEF	1.885	(47.9)	2.228	(56.6)	1.358	(34.5)	1.790	(45.5)	.706	(17.9)	1.081	(27.5)
28+	1.750 - 18 UNS	2.135	(54.2)	2.528	(64.2)	1.572	(39.9)	2.035	(51.7)	.750	(19.1)	1.187	(30.1)
32+	2.000 - 18 UNS	2.395	(60.8)	2.591	(65.8)	1.797	(45.6)	2.386	(60.6)	.875	(22.2)	1.250	(31.8)
36+	2.250 - 16 UN	2.635	(66.9)	2.716	(69.0)	1.922	(48.8)	2.496	(63.4)	.938	(23.8)	1.375	(34.9)
40+	2.500 - 16 UN	2.885	(73.3)	2.841	(72.2)	2.047	(52.0)	2.566	(65.2)	.938	(23.8)	1.500	(38.1)
44+	2.750 - 16 UN	3.135	(79.6)	3.091	(78.5)	2.296	(58.3)	2.860	(72.6)	1.188	(30.2)	1.750	(44.5)
48+	3.000 - 16 UN	3.385	(86.0)	3.216	(81.7)	2.421	(61.5)	3.344	(84.9)	1.312	(33.3)	1.875	(47.6)
61*+	1.500 - 18 UNEF	-	-	-	-	1.388	(35.3)	1.775	(45.1)	.706	(17.9)	1.081	(27.5)

* Not Available in Self Locking + Not Available under M83723/15A

Dimensions in inches (millimeters) and are subject to change without notice.

AS85049/52 and MS3417 Straight Strain Relief Self-Locking or Non-Self-Locking



AS85049

B

CONNECTOR DESIGNATOR:	
A	AS50151 Series AS34001 Crimp, MIL-DTL-26482 Series II, SAE-AS1703 Crimp Series III, MIL-DTL-83723 Series I & III

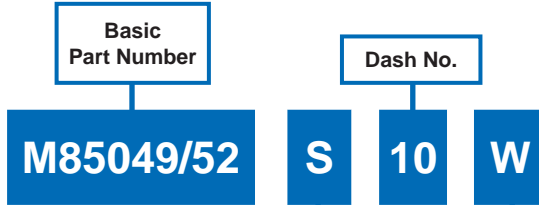

**FOR NEW DESIGN
USE AS85049/118**

Superseded Part Number		
MS3417-10 A		
Basic Part No. (Non-Self-Locking)	Dash No.	Metal and Finish Designator
		A = Aluminum 1000 Hour Cadmium Olive Drab over Electroless Nickel C = Aluminum, Cadmium Olive Drab G = Aluminum Black Anodize N = Aluminum, Electroless Nickel

S = Self-Locking
-1 = Non-Self-Locking
N = Non-Detented

Material and Finish Designator
A = Aluminum, Black Anodize
N = Aluminum, Electroless Nickel
S = Stainless Steel, Passivate
W = Aluminum, 1000 Hr. Cadmium O.D. over Electroless Nickel

APPLICATION NOTES

1. Assembly to be identified with manufacturer's name and part number, space permitting.
2. Cable Entry is defined as the accommodation entry for the wire bundle or cable.
3. Dimensions are not intended for inspection criteria.
4. For complete dimensions, see the applicable Military Specification.
5. Metric dimensions (mm) are in parentheses.

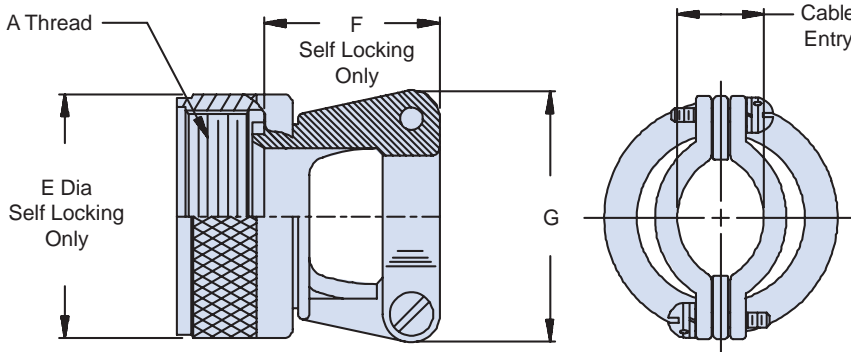

Dash No.	A Thread Class 2B	Ø E Max		F Max		G Max	Cable Entry			
		Self-Locking		Self-Locking			Min	Max		
3*+	.562 - 24 UNEF	-	-	-	-	.782 (19.9)	.125 (3.2)	.204 (5.2)		
8	.500 - 20 UNF	.885 (22.5)		.73 (18.5)		.782 (19.9)	.125 (3.2)	.204 (5.2)		
10	.625 - 24 UNEF	1.010 (25.7)		.85 (21.6)		.862 (21.9)	.187 (4.7)	.286 (7.3)		
12	.750 - 20 UNEF	1.135 (28.8)		.98 (24.9)		1.003 (24.6)	.291 (7.4)	.416 (10.6)		
14	.875 - 20 UNEF	1.260 (32.0)		.98 (24.9)		1.061 (25.5)	.351 (8.9)	.476 (12.1)		
16	1.000 - 20 UNEF	1.385 (35.2)		1.10 (27.9)		1.234 (26.9)	.501 (12.7)	.626 (15.9)		
18	1.062 - 18 UNEF	1.510 (38.4)		1.35 (34.3)		1.466 (35.4)	.518 (13.2)	.706 (17.9)		
20	1.188 - 18 UNEF	1.635 (41.5)		1.98 (50.3)		1.572 (37.2)	.581 (14.8)	.831 (21.1)		
22	1.313 - 18 UNEF	1.760 (44.7)		2.73 (69.3)		1.688 (39.9)	.644 (16.4)	.956 (24.3)		
24	1.438 - 18 UNEF	1.885 (47.9)		2.88 (73.2)		1.790 (43.1)	.706 (17.9)	1.081 (27.5)		
28+	1.750 - 18 UNS	2.135 (54.2)		2.528 (64.2)		2.035 (45.5)	.750 (19.1)	1.187 (30.1)		
32+	2.000 - 18 UNS	2.395 (60.8)		2.591 (65.8)		2.386 (51.7)	.875 (22.2)	1.250 (31.8)		
36+	2.250 - 16 UN	2.635 (66.9)		2.13 (54.1)		2.446 (60.6)	.938 (23.8)	1.375 (34.9)		
40+	2.500 - 16 UN	2.885 (73.3)		2.44 (62.0)		2.566 (65.2)	.938 (23.8)	1.500 (38.1)		
44+	2.750 - 16 UN	3.135 (79.6)		3.00 (76.2)		2.860 (72.6)	1.188 (30.2)	1.750 (44.5)		
48+	3.000 - 16 UN	3.385 (86.0)		3.40 (86.4)		3.344 (84.9)	1.312 (33.3)	1.875 (47.6)		
61*+	1.500 - 18 UNEF	-	-	-	-	1.775 (45.1)	.706 (17.9)	1.081 (27.5)		

* Not Available in Self Locking + Not Available under M83723/15S

Dimensions in inches (millimeters) and are subject to change without notice.

CONNECTOR DESIGNATOR:

A

AS50151 Series AS34001
MIL-DTL-26482 Series II
AS81703 Series III
MIL-DTL-83723 Series I and III
40M39569, DEF 5326-3, EN2997
EN3646, ESC 10, ESC 11, LN 29504
NFC93422 Series HE302
PAN 6432-1, PAN 6432-2, PATT 602

Configuration

— = Non-Self-Locking
G = Non-Self-Locking with Ground Lug*
S = Detented, Self-Locking*
T = Detented, Self-Locking with Ground Lug
N = Non-Detented, Self-Locking
H = Non-Detented, Self-Locking with Ground Lug
*Configuration Options G and S are available only with AS85049/55

Finish

A = Anodize, Black
N = Electroless Nickel
W = 1,000 Hour Cadmium Olive Drab over Electroless Nickel
X = Nickel Fluorocarbon Polymer
Y = Pure Dense Electrodeposited Aluminum
Z = Zinc-Nickel, Black

Shell Size

M85049/55

G

22

N

OPTIONAL SELF-LOCKING COUPLING

Basic Part Number

M85049/53 = Straight
M85049/54 = 45°
M85049/55 = 90°

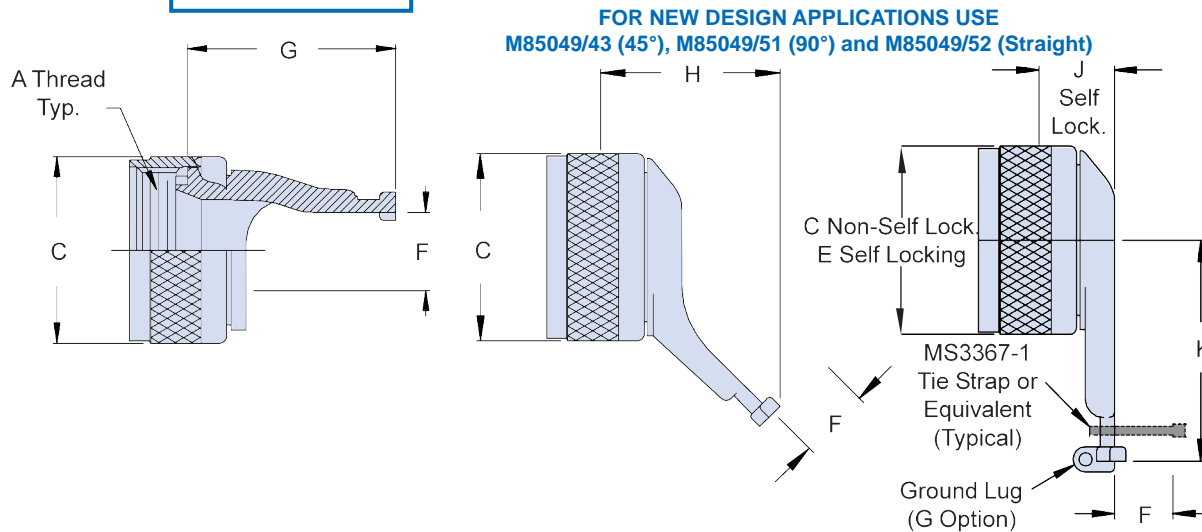

TABLE I: Shell Size, Thread, Cable Entry and Backshell Dimensions

Shell Size	A Thread Class 2B	C Dia Max	E Dia Max	F Cable Entry	G Max	H Max	J Max	K Max
03	562 - 24 UNEF	.780 (19.8)	1.010 (25.7)	.260 (6.6)	.954 (24.0)	1.232 (31.3)	.730 (18.5)	1.290 (32.8)
08	.500 - 20 UNF	.660 (16.8)	.890 (22.6)	.260 (6.6)	.954 (24.0)	1.232 (31.3)	.730 (18.5)	1.290 (31.0)
10	.625 - 24 UNEF	.780 (19.8)	1.010 (25.7)	.365 (9.3)	.954 (24.0)	1.232 (31.3)	.730 (18.5)	1.290 (32.8)
12	.750 - 20 UNEF	.940 (23.9)	1.140 (29.0)	.501 (12.7)	.954 (24.0)	1.232 (31.3)	.730 (18.5)	1.620 (41.1)
14	.875 - 20 UNEF	1.050 (26.7)	1.260 (32.0)	.575 (14.6)	1.204 (30.6)	1.232 (31.3)	.730 (18.5)	1.660 (42.2)
16	1.000 - 20 UNEF	1.240 (31.5)	1.390 (35.3)	.700 (17.8)	1.204 (30.6)	1.232 (31.3)	.730 (18.5)	1.720 (43.7)
18	1.062 - 18 UNEF	1.380 (35.1)	1.510 (38.4)	.779 (19.8)	1.204 (30.6)	1.232 (31.3)	.730 (18.5)	1.720 (43.7)
20	1.188 - 18 UNEF	1.500 (38.1)	1.640 (41.7)	.904 (23.0)	1.310 (33.3)	1.482 (37.6)	.750 (19.1)	1.790 (45.5)
22	1.313 - 18 UNEF	1.630 (41.4)	1.760 (44.7)	1.029 (26.1)	1.430 (36.3)	1.482 (37.6)	.750 (19.1)	1.850 (47.0)
24	1.438 - 18 UNEF	1.750 (44.5)	1.890 (48.0)	1.144 (29.1)	1.560 (39.6)	1.482 (37.6)	.750 (19.1)	1.910 (48.5)
28	1.750 - 18 UNS	1.970 (50.0)	2.140 (54.4)	1.379 (35.0)	1.560 (39.6)	1.469 (37.3)	.750 (19.1)	2.060 (52.3)

APPLICATION NOTES

1. Assembly identified with manufacturer's name and part number, space permitting.
2. For complete dimensions, see the applicable Military Specification.
3. Cable entry is defined as the accommodation range for the wire bundle or cable. Dimensions shown are not intended for inspection criteria.
4. Metric dimensions (mm) are in parentheses.

Dimensions in inches (millimeters) and are subject to change without notice.

AS85049/56 and AS85049/57
Straight and 45° Qwik-Ty Strain Reliefs
 Optional Self-Locking • Optional Ground Lug



AS85049

CONNECTOR DESIGNATOR:
F MIL-DTL-38999 Series I and II

Configuration
N = Non-Detented
G = Self-Locking with Ground Lug
H = Non-Detented with Ground Lug
S = Self-Locking without Ground Lug
 — = Non Self-Locking

Finish
A = Anodize, Black
N = Electroless Nickel
W = 1,000 Hour Cadmium Olive Drab over Electroless Nickel
X = Nickel Fluorocarbon Polymer
Y = Pure Dense Electrodeposited Aluminum
Z = Zinc-Nickel, Black

Basic Part Number
M85049/56 = Straight
M85049/57 = 45°

M85049/57

G

16

W

OPTIONAL SELF-LOCKING COUPLING

B

Shell Size

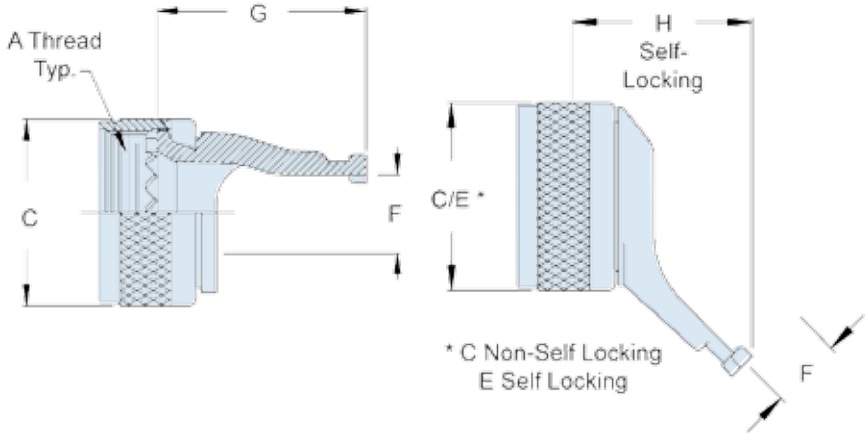

TABLE I: Shell Size, Thread, Cable Entry and Backshell Dimensions

Shell Size Series II	Series I Shell Size Ref.	A Thread Class 2B	C Dia Max	E Dia Max	F Cable Entry	G Max	H Max
8	9	.438-28 UNEF	.750 (19.1)	.860 (21.8)	.264 (6.7)	.895 (22.7)	1.210 (30.7)
10	11	.562-24 UNEF	.850 (21.6)	.980 (24.9)	.392 (10.0)	.895 (22.7)	1.210 (30.7)
12	13	.688-24 UNEF	1.000 (25.4)	1.160 (29.5)	.506 (12.9)	.955 (24.3)	1.390 (35.3)
14	15	.813-20 UNEF	1.100 (27.9)	1.280 (32.5)	.631 (16.0)	1.135 (28.8)	1.390 (35.3)
16	17	.938-20 UNEF	1.250 (31.8)	1.410 (35.8)	.756 (19.2)	1.135 (28.8)	1.390 (35.3)
18	19	1.063-18 UNEF	1.400 (35.6)	1.520 (38.6)	.845 (21.5)	1.195 (30.4)	1.390 (35.3)
20	21	1.188-18 UNEF	1.500 (38.1)	1.640 (41.7)	.970 (24.6)	1.325 (33.7)	1.390 (35.3)
22	23	1.313-18 UNEF	1.650 (41.9)	1.770 (45.0)	1.095 (27.8)	1.445 (36.7)	1.390 (35.3)
24	25	1.438-18 UNEF	1.750 (44.5)	1.890 (48.0)	1.220 (31.0)	1.585 (40.3)	1.390 (35.3)

- APPLICATION NOTES**
1. Assembly identified with manufacturer's name and part number, space permitting.
 2. For complete dimensions, see the applicable Military Specification.
 3. Cable entry is defined as the accommodation range for the wire bundle or cable. Dimensions shown are not intended for inspection criteria.
 4. Metric dimensions (mm) are in parentheses.

Dimensions in inches (millimeters) and are subject to change without notice.

CONNECTOR DESIGNATOR:

F MIL-DTL-38999 Series I and II

Basic Part Number

Dash Number

M85049/58 - 10

TABLE I: Dash Number, Shell Size and Dimensions

Dash No.	Shell Size (Ref)	A Thread UNEF-2B	B Dia Max	C Dia Max	D Dia ±.005 (.1)
8	8/9	.4375-28	.600 (15.2)	.506 (12.9)	.344 (8.7)
10	10/11	.5625-24	.726 (18.4)	.631 (16.0)	.472 (12.0)
12	12/13	.6875-24	.850 (21.6)	.756 (19.2)	.586 (14.9)
14	14/15	.8125-20	.976 (24.8)	.881 (22.4)	.711 (18.1)
16	16/17	.9375-20	1.012 (25.7)	1.006 (25.6)	.836 (21.2)
18	18/19	1.0625-18	1.226 (31.1)	1.131 (28.7)	.942 (23.9)
20	20/21	1.1875-18	1.352 (34.3)	1.256 (31.9)	1.067 (27.1)
22	22/23	1.3125-18	1.476 (37.5)	1.381 (35.1)	1.192 (30.3)
24	24/25	1.4375-18	1.602 (40.7)	1.506 (38.3)	1.317 (33.5)

APPLICATION NOTES

- For complete dimensions see the applicable Military Specification.
- Finish: 500-Hour Cadmium Olive Drab over Electroless Nickel.
- See Pages 30-5 and 68-14 or the AS85049/75 Potting Boot which can be used with this potting ring.
- Metric dimensions (mm) are in parentheses.

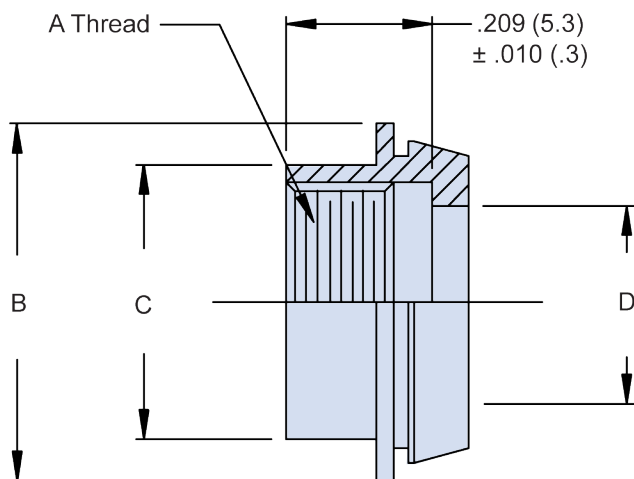
Dimensions in inches (millimeters) and are subject to change without notice.

AS85049/59 Straight Shrink Boot Adapter



AS85049

B

CONNECTOR DESIGNATOR:	
C	MIL-DTL-22992

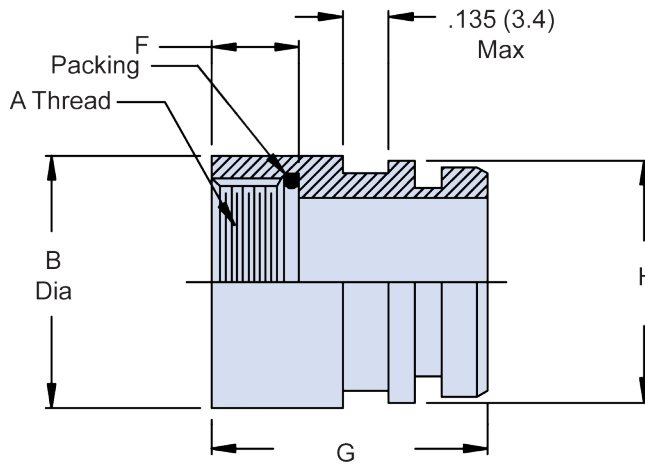
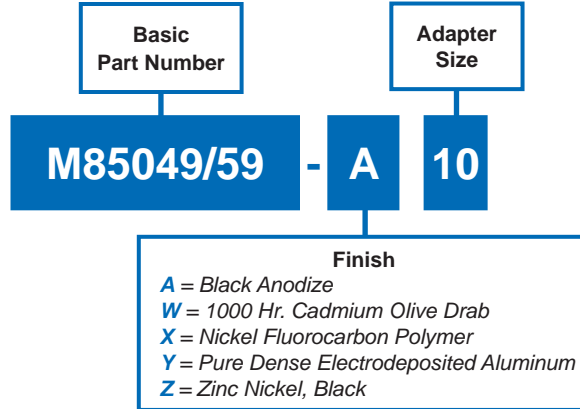

Adapter Size	A Thread Class 2B-LH	B Max	F ±.016 (0.4)	G ±.031 (0.8)	H Dia ±.010 (0.3)
12	.750 - 20 UNEF	.933 (23.7)	.479 (6.4)	1.175 (29.8)	.798 (20.3)
14	.875 - 20 UNEF	1.057 (26.8)	.479 (6.4)	1.175 (29.8)	.922 (23.4)
16	1.000 - 20 UNEF	1.182 (30.0)	.479 (6.4)	1.175 (29.8)	1.048 (26.6)
18	1.125 - 18 UNEF	1.307 (33.2)	.479 (6.4)	1.175 (29.8)	1.172 (29.8)
20	1.250 - 18 UNEF	1.432 (36.4)	.479 (6.4)	1.175 (29.8)	1.297 (32.9)
22	1.375 - 18 UNEF	1.557 (39.5)	.479 (6.4)	1.175 (29.8)	1.423 (36.1)
24	1.625 - 18 UNEF	1.797 (45.6)	.479 (6.4)	1.175 (29.8)	1.662 (42.2)
28	1.875 - 16 UN	2.057 (52.2)	.479 (6.4)	1.175 (29.8)	1.922 (48.8)
32	2.062 - 16 UN	2.307 (58.6)	.479 (6.4)	1.175 (29.8)	2.172 (55.2)
36	2.312 - 16 UN	2.557 (64.9)	.479 (6.4)	1.175 (29.8)	2.422 (61.5)
40	2.625 - 16 UN	2.869 (72.9)	.667 (16.9)	1.375 (44.9)	2.734 (69.4)
44	2.875 - 16 UN	3.120 (79.2)	.667 (16.9)	1.375 (44.9)	2.982 (75.7)

1.	For complete dimensions see the applicable Military Specification.
2.	Metric dimensions (mm) are in parentheses.

Dimensions in inches (millimeters) and are subject to change without notice.

CONNECTOR DESIGNATOR:
A

AS50151 Series AS34001
MIL-DTL-26482 Series II
AS81703 Series III
MIL-DTL-83723 Series I & III
40M39569, DEF 5326-3
EN 2997, EN 3646
ESC 10, ESC 11, LN 29504
NFC93422 Series HE302
PAN 6432-1, PAN 6432-2
PATT 602

B
Basic Part Number
M85049/60-1
Shell Size
W
22
Finish

A = Black Anodize
N = Electroless Nickel
W = 1000 Hr. Cadmium Olive Drab
X = Nickel Fluorocarbon Polymer
Y = Pure Dense Electrodeposited Aluminum
Z = Zinc Nickel, Black

Superseded Part Number
Basic Part Number
MS3158
Shell Size
- 22 C

Finish
C = Cadmium Olive Drab over Electroless Nickel
N = Electroless Nickel

APPLICATION NOTES

- For complete dimensions see the applicable Military Specification.
- Metric dimensions (mm) are in parentheses.

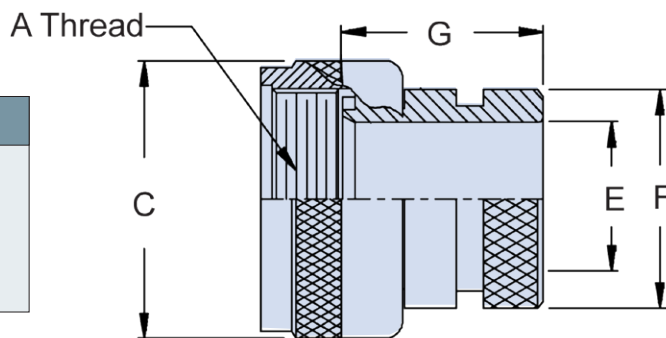
TABLE I: Shell Size, Thread and Dimensions

Shell Size	A Thread Class 2B	C Dia Max +.000 (0.0) -.045 (1.14)	E Min Dia	F Dia +.000 (0.0) -.020 (0.5)	G Max
3	.562 - 24 UNEF	.670 (17.0)	.250 (6.4)	.533 (13.5)	.832 (21.1)
8	.500 - 20 UNF	.620 (15.7)	.250 (6.4)	.533 (13.5)	.832 (21.1)
10	.625 - 24 UNEF	.740 (18.8)	.355 (9.0)	.605 (15.4)	.832 (21.1)
12	.750 - 20 UNEF	.860 (21.8)	.491 (12.5)	.774 (19.7)	.832 (21.1)
14	.875 - 20 UNEF	.980 (24.9)	.565 (14.4)	.838 (21.3)	.832 (21.1)
16	1.000 - 20 UNEF	1.110 (28.2)	.690 (17.5)	.963 (24.5)	.832 (21.1)
18	1.062 - 18 UNEF	1.220 (31.0)	.769 (19.5)	1.042 (26.5)	.832 (21.1)
20	1.188 - 18 UNEF	1.350 (34.3)	.894 (22.7)	1.217 (30.9)	.832 (21.1)
22	1.313 - 18 UNEF	1.470 (37.3)	1.019 (25.9)	1.355 (34.4)	.832 (21.1)
24	1.438 - 18 UNEF	1.590 (40.4)	1.134 (28.8)	1.443 (36.7)	.832 (21.1)
28	1.750 - 18 UNS	1.970 (50.0)	1.369 (34.8)	1.709 (43.4)	.994 (25.3)
32	2.000 - 18 UNS	2.220 (56.4)	1.615 (41.0)	1.919 (48.7)	.994 (25.3)
36	2.250 - 16 UN	2.470 (62.7)	1.830 (46.5)	2.169 (55.1)	.994 (25.3)
40	2.500 - 16 UN	2.720 (69.1)	2.045 (51.9)	2.402 (61.0)	.994 (25.3)
44	2.750 - 16 UN	2.970 (75.4)	2.300 (58.4)	2.657 (67.5)	.994 (25.3)
48	3.000 - 16 UN	3.220 (81.8)	2.550 (64.8)	2.907 (73.8)	.994 (25.3)
61	1.500 - 18 UNEF	1.650 (41.9)	1.174 (29.8)	1.529 (38.8)	.832 (21.1)

Dimensions in inches (millimeters) and are subject to change without notice.

AS85049/60-2G and MS3416-G Straight Shrink Boot Adapter



AS85049

CONNECTOR DESIGNATOR:

A

AS50151 Series AS34001
MIL-DTL-26482 Series II
AS81703 Series III
MIL-DTL-83723 Series I & III
40M39569, DEF 5326-3
EN 2997, EN 3646
ESC 10, ESC 11, LN 29504
NFC93422 Series HE302
PAN 6432-1, PAN 6432-2
PATT 602

Basic Part Number

Shell Size

M85049/60-2G

22

W

Finish

A = Black Anodize
W = 1000 Hr. Cadmium Olive Drab
X = Nickel Fluorocarbon Polymer
Y = Pure Dense Electrodeposited Aluminum
Z = Zinc Nickel, Black

Superseded Part Number

Basic Part Number

Shell Size

Style

MS3416

-22

G

C

Finish

A = 1,000 Hr. Cadmium Olive Drab
C = Cadmium Olive Drab
N = Electroless Nickel

B

APPLICATION NOTES

- For complete dimensions see the applicable Military Specification.
- Metric dimensions (mm) are in parentheses.

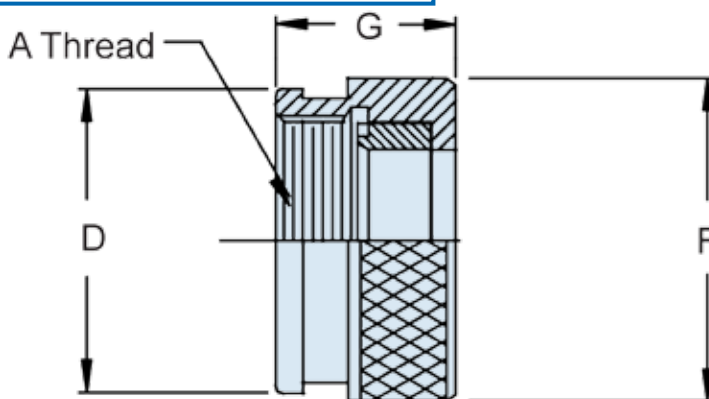

TABLE I: Shell Size, Thread and Dimensions

Shell Size	A Thread Class 2B	D Dia +.000 (0.0) -.020 (0.5)	F Dia +.000 (0.0) -.045 (1.1)	G Max
3	.562 - 24 UNEF	.709 (18.0)	.750 (19.1)	.540 (13.7)
8	.500 - 20 UNF	.657 (16.7)	.688 (17.5)	.540 (13.7)
10	.625 - 24 UNEF	.774 (19.7)	.803 (20.4)	.540 (13.7)
12	.750 - 20 UNEF	.898 (22.8)	.938 (23.8)	.540 (13.7)
14	.875 - 20 UNEF	1.024 (26.0)	1.063 (27.0)	.540 (13.7)
16	1.000 - 20 UNEF	1.152 (29.3)	1.238 (31.4)	.540 (13.7)
18	1.062 - 18 UNEF	1.243 (31.6)	1.310 (33.3)	.540 (13.7)
20	1.188 - 18 UNEF	1.370 (34.8)	1.436 (36.5)	.540 (13.7)
22	1.313 - 18 UNEF	1.443 (36.7)	1.560 (39.6)	.540 (13.7)
24	1.438 - 18 UNEF	1.618 (41.1)	1.686 (42.8)	.540 (13.7)
28	1.750 - 18 UNS	1.969 (50.0)	2.062 (52.4)	.702 (17.8)
32	2.000 - 18 UNS	2.219 (56.4)	2.312 (58.7)	.702 (17.8)
36	2.250 - 16 UN	2.469 (62.7)	2.562 (65.1)	.702 (17.8)
40	2.500 - 16 UN	2.719 (69.1)	2.812 (71.4)	.702 (17.8)
44	2.750 - 16 UN	2.969 (75.4)	3.062 (77.8)	.702 (17.8)
48	3.000 - 16 UN	3.219 (81.8)	3.312 (84.1)	.702 (17.8)
61	1.500 - 18 UNEF	1.653 (42.0)	1.748 (44.4)	.540 (13.7)

Dimensions in inches (millimeters) and are subject to change without notice.

CONNECTOR DESIGNATOR:

F MIL-DTL-27599

Basic Part Number

Dash Number

M85049/61 - 10

TABLE I: Dash Number and Dimensions

Dash No.	Shell Size (Ref)	A Thread UNEF-2B	B Dia Max	C Dia Max	D Dia $\pm .005 (.1)$
8	8/9	.4375-28	.594 (15.1)	.521 (13.2)	.476 (12.1)
10	10/11	.5625-24	.734 (18.6)	.647(16.4)	.602 (15.3)
12	12/13	.6875-24	.844 (21.4)	.771 (19.6)	.726 (18.4)
14	14/15	.8125-20	.969 (24.6)	.897 (22.8)	.852 (21.6)
16	16/17	.9375-20	1.094 (27.8)	1.023 (26.0)	.978 (24.8)
18	18/19	1.0625-18	1.234 (31.3)	1.147 (29.1)	1.102 (28.0)
20	20/21	1.1875-18	1.344 (34.1)	1.273 (32.3)	1.228 (31.2)
22	22/23	1.3125-18	1.469 (37.3)	1.397 (35.5)	1.352 (34.3)
24	24/25	1.4375-18	1.594 (40.5)	1.524 (38.7)	1.478 (37.5)

APPLICATION NOTES

- For complete dimensions see the applicable Military Specification.
- Finish: 500-Hour Cadmium Olive Drab over Electroless Nickel.
- See Pages 30-4 and 68-13 for the AS85049/75 Potting Boot which can be used with this potting ring and Page 88-13
- Metric dimensions (mm) are in parentheses.

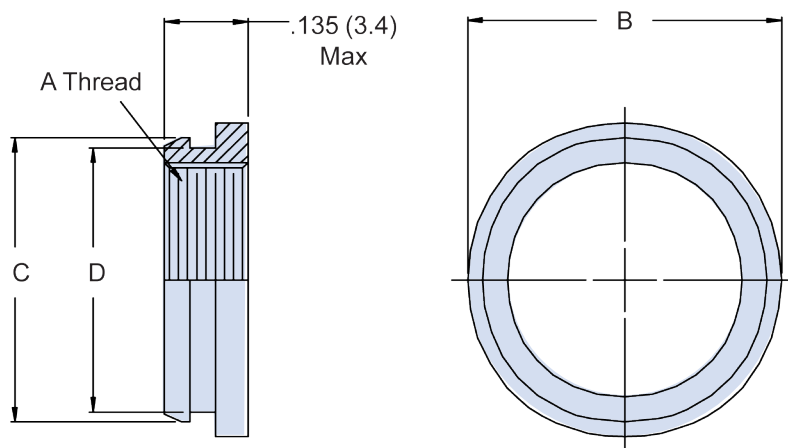
Dimensions in inches (millimeters) and are subject to change without notice.

AS85049/62 and M38999/2 Straight Shrink Boot Adapter



AS85049

B

CONNECTOR DESIGNATOR:	
F	MIL-DTL-38999 Series I & II 40M38277, PAN 6433-1 PATT 614, PATT 616 NFC93422 Series HE308 & HE309

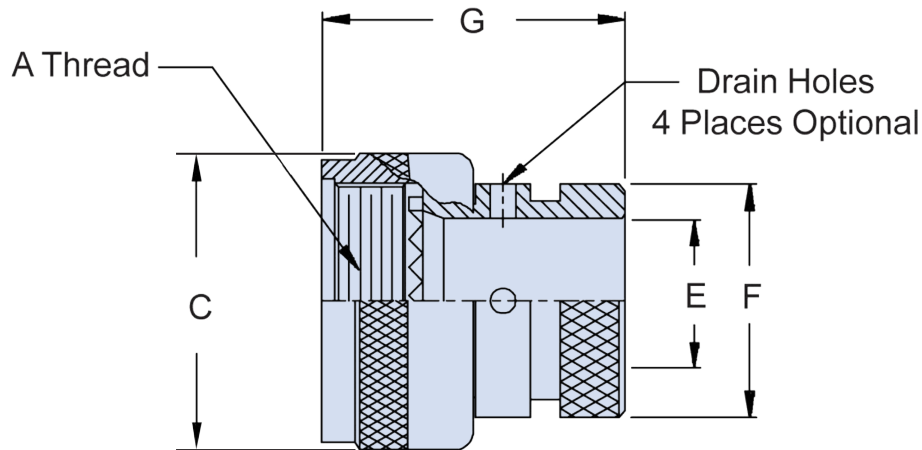
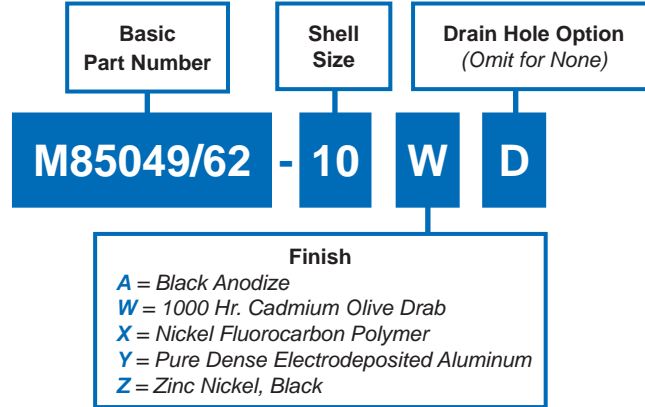

TABLE I: Shell Size, Thread and Dimensions					
Shell Size	A Thread Class 2B	C Max	E Dia Min	F Dia Min	G Max
08	.438 - 28 UNEF	.750 (19.1)	.250 (6.4)	.533 (13.5)	1.000 (25.4)
10	.562 - 24 UNEF	.850 (21.6)	.375 (9.5)	.605 (15.4)	1.000 (25.4)
12	.688 - 24 UNEF	1.000 (25.4)	.500 (12.7)	.774 (19.7)	1.000 (25.4)
14	.813 - 20 UNEF	1.100 (27.9)	.625 (15.9)	.838 (21.3)	1.000 (25.4)
16	.938 - 20 UNEF	1.250 (31.8)	.750 (19.1)	.963 (24.5)	1.000 (25.4)
18	1.063 - 18 UNEF	1.400 (35.6)	.812 (20.6)	1.042 (26.5)	1.000 (25.4)
20	1.188 - 18 UNEF	1.500 (38.1)	.937 (23.8)	1.217 (30.9)	1.000 (25.4)
22	1.313 - 18 UNEF	1.650 (41.9)	1.062 (27.0)	1.355 (34.4)	1.000 (25.4)
24	1.438 - 18 UNEF	1.750 (44.5)	1.188 (30.2)	1.443 (36.7)	1.000 (25.4)

APPLICATION NOTES
1. For complete dimensions see the applicable Military Specification.
2. Metric dimensions (mm) are in parentheses.

Dimensions in inches (millimeters) and are subject to change without notice.



AS85049/63

90° Qwik-Ty Strain Relief

Optional Self-Locking • Optional Ground Lug

CONNECTOR DESIGNATOR:
F MIL-DTL-38999 Series I and II

Configuration

N = Non-Detented
G = Self-Locking with Ground Lug
H = Non-Detented with Ground Lug
S = Self-Locking without Ground Lug
 — = Non Self-Locking

Finish

A = Anodize, Black
N = Electroless Nickel
W = 1,000 Hour Cadmium Olive Drab over Electroless Nickel
X = Nickel Fluorocarbon Polymer
Y = Pure Dense Electrodeposited Aluminum
Z = Zinc-Nickel, Black

Basic Part Number
 M85049/63 = 90°

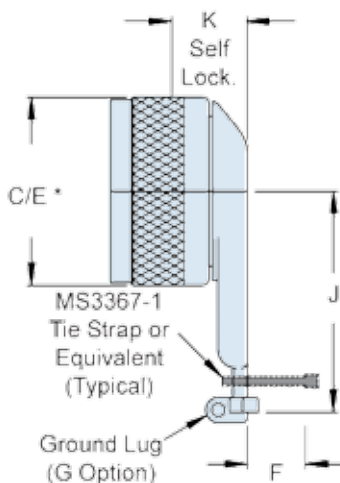
M85049/63
G
16
W
**OPTIONAL
 SELF-LOCKING
 COUPLING**
**Shell
 Size**

TABLE I: Shell Size, Thread, Cable Entry and Backshell Dimensions

Shell Size Series II	Series I Shell Size Ref.	A Thread Class 2B	C Dia Max	E Dia Max	F Cable Entry	J Max	K Self-Locking
8	9	.438-28 UNEF	.750 (19.1)	.860 (21.8)	.264 (6.7)	1.220 (31.0)	.630 (16.0)
10	11	.562-24 UNEF	.850 (21.6)	.980 (24.9)	.392 (10.0)	1.290 (32.8)	.630 (16.0)
12	13	.688-24 UNEF	1.000 (25.4)	1.160 (29.5)	.506 (12.9)	1.620 (41.1)	.630 (16.0)
14	15	.813-20 UNEF	1.100 (27.9)	1.280 (32.5)	.631 (16.0)	1.660 (42.2)	.700 (17.8)
16	17	.938-20 UNEF	1.250 (31.8)	1.410 (35.8)	.756 (19.2)	1.720 (43.7)	.700 (17.8)
18	19	1.063-18 UNEF	1.400 (35.6)	1.520 (38.6)	.845 (21.5)	1.720 (43.7)	.730 (18.5)
20	21	1.188-18 UNEF	1.500 (38.1)	1.640 (41.7)	.970 (24.6)	1.790 (45.5)	.730 (18.5)
22	23	1.313-18 UNEF	1.650 (41.9)	1.770 (45.0)	1.095 (27.8)	1.850 (47.0)	.730 (18.5)
24	25	1.438-18 UNEF	1.750 (44.5)	1.890 (48.0)	1.220 (31.0)	1.910 (48.5)	.730 (18.5)

APPLICATION NOTES

1. Assembly identified with manufacturer's name and part number, space permitting.
2. For complete dimensions, see the applicable Military Specification.
3. Cable entry is defined as the accommodation range for the wire bundle or cable. Dimensions shown are not intended for inspection criteria.
4. Metric dimensions (mm) are in parentheses.

Dimensions in inches (millimeters) and are subject to change without notice.

AS85049/69 Straight Shrink Boot Adapter



AS85049

B

CONNECTOR DESIGNATOR:	
H	MIL-DTL-38999 Series III & IV EN3645

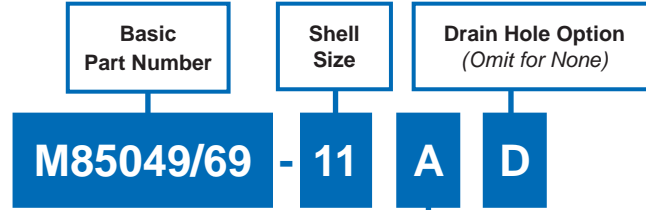

Finish
<i>A = Black Anodize</i>
<i>N = Electroless Nickel</i>
<i>W = 1000 Hr. Cadmium Olive Drab</i>
<i>X = Nickel Fluorocarbon Polymer</i>
<i>Y = Pure Dense Electrodeposited Aluminum</i>
<i>Z = Zinc Nickel, Black</i>

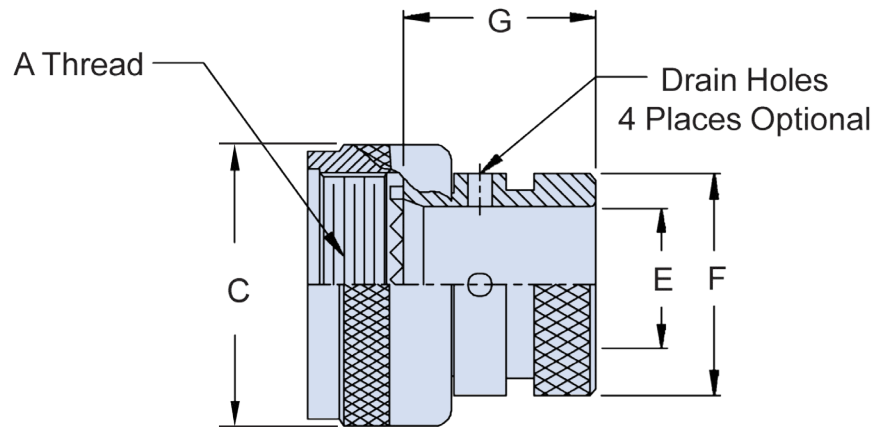

TABLE I: Shell Size, Thread and Dimensions

Shell Size	A Thread Class 6H	C Max	E Dia Min	F Dia Max	G Max
9	M12 X 1 - 6H	.750 (19.1)	.250 (6.4)	.533 (13.5)	.710 (18.0)
11	M15 X 1 - 6H	.850 (21.6)	.375 (9.5)	.605 (15.4)	.710 (18.0)
13	M18 X 1 - 6H	1.000 (25.4)	.500 (12.7)	.774 (19.7)	.710 (18.0)
15	M22 X 1 - 6H	1.150 (29.2)	.625 (15.9)	.838 (21.3)	.710 (18.0)
17	M25 X 1 - 6H	1.250 (31.8)	.750 (19.1)	.963 (24.5)	.710 (18.0)
19	M28 X 1 - 6H	1.400 (35.6)	.812 (20.6)	1.042 (26.5)	.710 (18.0)
21	M31 X 1 - 6H	1.550 (39.4)	.938 (23.8)	1.217 (30.9)	.710 (18.0)
23	M34 X 1 - 6H	1.650 (41.9)	1.062 (27.0)	1.355 (34.4)	.710 (18.0)
25	M37 X 1 - 6H	1.785 (47.0)	1.188 (30.2)	1.443 (36.7)	.710 (18.0)

APPLICATION NOTES

1. For complete dimensions see the applicable Military Specification.
2. Metric dimensions (mm) are in parentheses.

Dimensions in inches (millimeters) and are subject to change without notice.

For Use with
AS85049/61
Potting Boot Ring
(Page B-84)

Basic Part Number

Shell Size

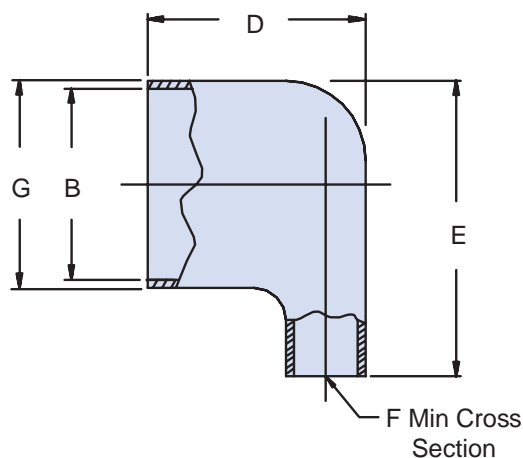
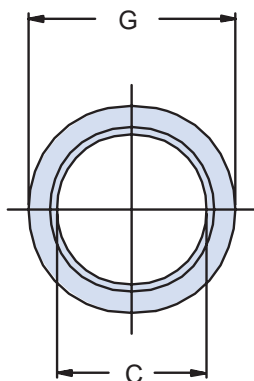
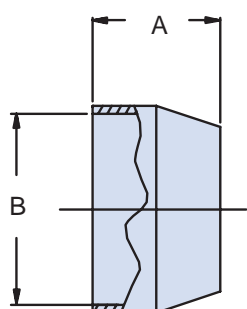
Geometry
1 - Straight
2 = 90°**M85049/74****- 10 -****1**
TABLE I: Shell Size and Dimensions

Shell Size	A Min	A Max	B Dia ± .005 (.1)	G Max	C Min ID	D Max	E Max	F Min
8	.450 (11.4)	.500 (12.7)	.511 (13.0)	.608 (15.4)	.317 (8.1)	.766 (19.5)	1.000 (25.4)	.110 (2.8)
10	.450 (11.4)	.500 (12.7)	.637 (16.2)	.734 (18.6)	.434 (11.0)	.922 (23.4)	1.125 (28.6)	.200 (5.1)
12	.450 (11.4)	.500 (12.7)	.761 (19.3)	.858 (21.8)	.548 (13.9)	1.031 (26.2)	1.125 (28.6)	.290 (7.4)
14	.450 (11.4)	.500 (12.7)	.887 (22.5)	.984 (25.0)	.673 (17.1)	1.016 (25.8)	1.297 (32.9)	.400 (10.2)
16	.450 (11.4)	.500 (12.7)	1.013 (25.7)	1.110 (28.2)	.798 (20.3)	1.016 (25.8)	1.375 (34.9)	.490 (12.4)
18	.450 (11.4)	.500 (12.7)	1.137 (28.9)	1.234 (31.3)	.899 (22.8)	1.078 (27.4)	1.469 (37.3)	.590 (15.0)
20	.550 (14.0)	.594 (15.1)	1.263 (32.1)	1.360 (34.5)	1.024 (26.0)	1.094 (27.8)	1.625 (41.3)	.730 (18.5)
22	.550 (14.0)	.594 (15.1)	1.387 (35.2)	1.484 (37.7)	1.149 (29.2)	1.094 (27.8)	1.703 (43.3)	.860 (21.8)
24	.550 (14.0)	.594 (15.1)	1.513 (38.4)	1.610 (40.9)	1.274 (32.4)	1.281 (32.5)	2.047 (52.0)	1.070 (27.2)

APPLICATION NOTES

- For complete dimensions see the applicable Military Specification.
- Material: Translucent nylon, minimum wall thickness .020 (.51).
- Metric dimensions (mm) are in parentheses.

Dimensions in inches (millimeters) and are subject to change without notice.

AS85049/75 Potting Boot



AS85049

For Use with
AS85049/58
Potting Boot Ring
(Page B-80)

Basic Part Number	Shell Size	Geometry 1 - Straight 2 = 90°
M85049/75	- 10 -	1

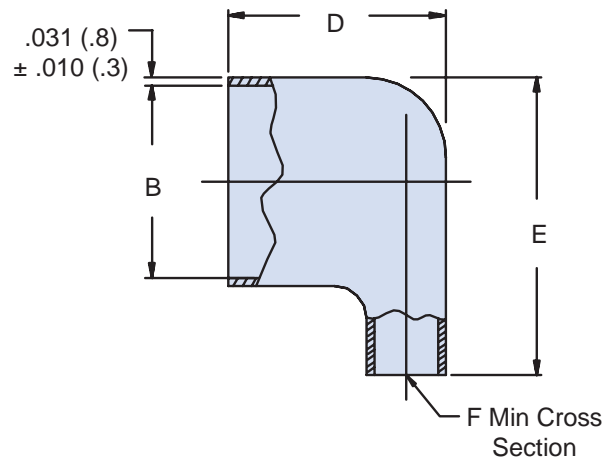
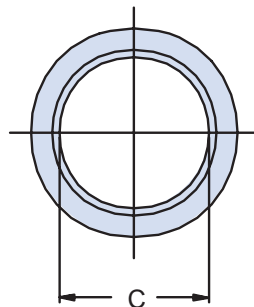
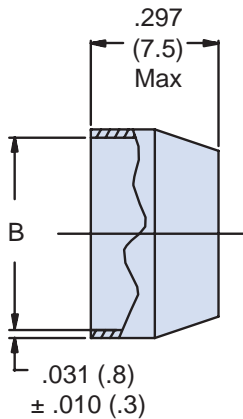

Shell Size	B Dia ± .005 (.1)	C Min ID	D Max	E Max	F Min
8	.527 (13.4)	.434 (11.0)	.438 (11.1)	.766 (19.5)	.073 (1.9)
10	.652 (16.6)	.548 (13.9)	.469 (11.9)	.891 (22.6)	.117 (3.0)
12	.776 (19.7)	.673 (17.1)	.562 (14.3)	1.031 (26.2)	.206 (5.2)
14	.898 (22.8)	.798 (20.3)	.719 (18.3)	1.156 (29.4)	.384 (9.8)
16	1.016 (25.8)	.899 (22.8)	.781 (19.8)	1.287 (32.7)	.443 (11.3)
18	1.140 (29.0)	1.024 (26.0)	.844 (21.4)	1.406 (35.7)	.561 (14.2)
20	1.265 (32.1)	1.149 (29.2)	.906 (23.0)	1.531 (38.9)	.693 (17.6)
22	1.390 (35.3)	1.274 (32.4)	.938 (23.8)	1.656 (42.1)	.840 (21.3)
24	1.515 (38.5)	1.399 (35.5)	1.031 (26.2)	1.781 (45.2)	.999 (25.4)

APPLICATION NOTES

- For complete dimensions see the applicable Military Specification.
- Material: Translucent nylon, minimum wall thickness .020 (.51).
- Metric dimensions (mm) are in parentheses.

Dimensions in inches (millimeters) and are subject to change without notice.

B



AS85049/76 90° EMI/RFI Environmental Backshell

CONNECTOR DESIGNATOR:

F MIL-DTL-38999 Series I and II

Finish

N = Electroless Nickel

X = Aluminum, Nickel Fluorocarbon Polymer

W = 1,000 Hr. Cadmium Olive Drab
over Electroless Nickel

Z = Aluminum, Zinc-Nickel, Black

M85049/76 - 10 W 01

Basic
Part Number

Dash Number
(Table I)

Clamp Size
(Tables II & III)

**TABLE I: Shell Size,
Thread and Dimensions**

Dash No.	Shell Size Series I	Shell Size Series II	A Thread Class 2B	C Dia Max
08	09	08	.438 - 28 UNEF	.750 (19.1)
10	11	10	.562 - 24 UNEF	.850 (21.6)
12	13	12	.688 - 24 UNEF	1.000 (25.4)
14	15	14	.813 - 20 UNEF	1.150 (29.2)
16	17	16	.938 - 20 UNEF	1.250 (31.8)
18	19	18	1.063 - 18 UNEF	1.400 (35.6)
20	21	20	1.188 - 18 UNEF	1.550 (39.4)
22	23	22	1.313 - 18 UNEF	1.650 (41.9)
24	25	24	1.438 - 18 UNEF	1.850 (47.0)

**TABLE II: Shell Size, Series 1 Reference,
Clamp Size and Dimensions**

Dash No.	Shell Size Series I	Shell Size Series II	Clamp Size		E ± .156 (4.0)	F ± .188 (4.8)
			Min	Max		
08	09	08	01	02	.532 (13.5)	3.267 (83.0)
10	11	10	01	03	.627 (15.9)	3.387 (86.0)
12	13	12	02	04	.642 (16.3)	3.407 (86.5)
14	15	14	02	05	.719 (18.3)	3.477 (88.3)
16	17	16	02	06	.774 (19.7)	3.567 (90.6)
18	19	18	03	07	.854 (21.7)	3.737 (94.9)
20	21	20	03	08	.899 (22.8)	3.737 (94.9)
22	23	22	03	09	1.009 (25.6)	3.847 (97.7)
24	25	24	04	10	1.024 (26.0)	3.847 (97.7)

APPLICATION NOTES

- For complete dimensions see the applicable Military Specification.
- Metric dimensions (mm) are in parentheses.
- Cable Range is defined as the accommodation range for the wire bundle or cable. Dimensions shown are not intended for inspection criteria.

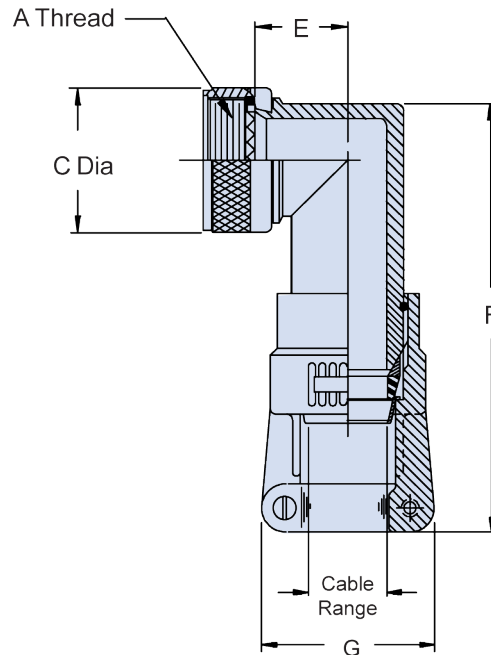

**TABLE III: Clamp Size,
Cable Range and Dimensions**

Clamp Size	Cable Range		G Max
	Min	Max	
01	.062 (1.6)	.125 (3.2)	.800 (20.3)
02	.125 (3.2)	.250 (6.4)	1.000 (25.4)
03	.250 (6.4)	.375 (9.5)	1.100 (27.9)
04	.375 (9.5)	.500 (12.7)	1.200 (30.5)
05	.500 (12.7)	.625 (15.9)	1.250 (31.8)
06	.625 (15.9)	.750 (19.1)	1.400 (35.6)
07	.750 (19.1)	.875 (22.2)	1.500 (38.1)
08	.875 (22.2)	1.000 (25.4)	1.650 (41.9)
09	1.000 (25.4)	1.125 (28.6)	1.750 (44.5)
10	1.125 (28.6)	1.250 (31.8)	1.900 (48.3)

Dimensions in inches (millimeters) and are subject to change without notice.

AS85049/77 45° EMI/RFI Environmental Backshell



AS85049

B

CONNECTOR DESIGNATOR:

F MIL-DTL-38999 Series I and II

Finish
N = Electroless Nickel **X** = Aluminum, Nickel Fluorocarbon Polymer
W = 1,000 Hr. Cadmium Olive Drab **Z** = Aluminum, Zinc-Nickel, Black over Electroless Nickel

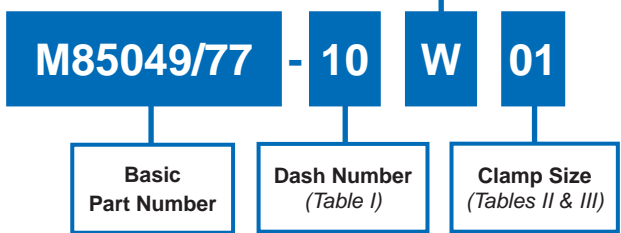

TABLE I: Shell Size, Thread and Dimensions

Dash No.	Shell Size Series I	Shell Size Series II	A Thread Class 2B	C Dia Max
08	09	08	.438 - 28 UNEF	.750 (19.1)
10	11	10	.562 - 24 UNEF	.850 (21.6)
12	13	12	.688 - 24 UNEF	1.000 (25.4)
14	15	14	.813 - 20 UNEF	1.150 (29.2)
16	17	16	.938 - 20 UNEF	1.250 (31.8)
18	19	18	1.063 - 18 UNEF	1.400 (35.6)
20	21	20	1.188 - 18 UNEF	1.550 (39.4)
22	23	22	1.313 - 18 UNEF	1.650 (41.9)
24	25	24	1.438 - 18 UNEF	1.850 (47.0)

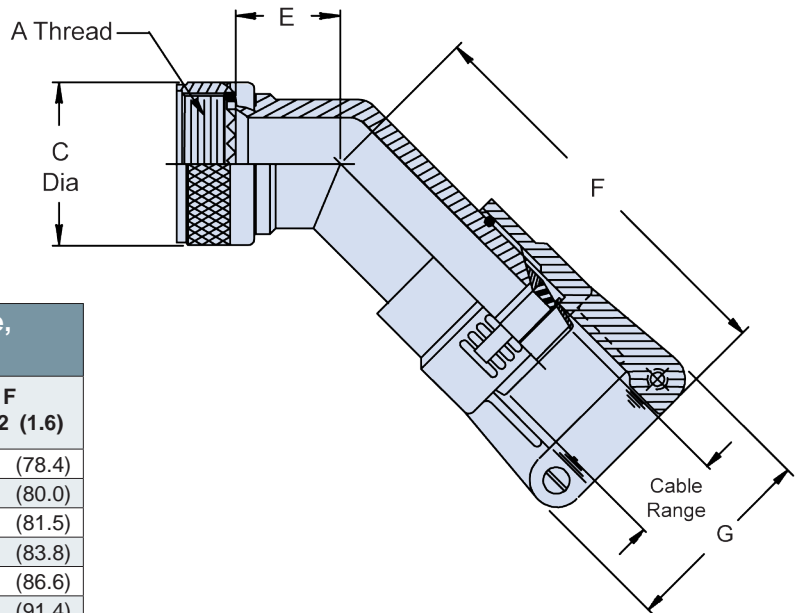

TABLE II: Shell Size, Series 1 Reference, Clamp Size and Dimensions

Dash No.	Shell Size Series I	Shell Size Series II	Clamp Size		E ±.062 (1.6)	F ±.062 (1.6)
			Min	Max		
08	09	08	01	02	.398 (10.1)	3.088 (78.4)
10	11	10	01	03	.458 (11.6)	3.148 (80.0)
12	13	12	02	04	.518 (13.2)	3.208 (81.5)
14	15	14	02	05	.588 (14.9)	3.298 (83.8)
16	17	16	02	06	.678 (17.2)	3.408 (86.6)
18	19	18	03	07	.868 (22.0)	3.598 (91.4)
20	21	20	03	08	.868 (22.0)	3.598 (91.4)
22	23	22	03	09	.958 (24.3)	3.748 (95.2)
24	25	24	04	10	.958 (24.3)	3.748 (95.2)

- APPLICATION NOTES**
- For complete dimensions see the applicable Military Specification.
 - Metric dimensions (mm) are in parentheses.
 - Cable Range is defined as the accommodation range for the wire bundle or cable. Dimensions shown are not intended for inspection criteria.

TABLE III: Clamp Size, Cable Range and Dimensions

Clamp Size	Cable Range		G Max
	Min	Max	
01	.062 (1.6)	.125 (3.2)	.800 (20.3)
02	.125 (3.2)	.250 (6.4)	1.000 (25.4)
03	.250 (6.4)	.375 (9.5)	1.100 (27.9)
04	.375 (9.5)	.500 (12.7)	1.200 (30.5)
05	.500 (12.7)	.625 (15.9)	1.250 (31.8)
06	.625 (15.9)	.750 (19.1)	1.400 (35.6)
07	.750 (19.1)	.875 (22.2)	1.500 (38.1)
08	.875 (22.2)	1.000 (25.4)	1.650 (41.9)
09	1.000 (25.4)	1.125 (28.6)	1.750 (44.5)
10	1.125 (28.6)	1.250 (31.8)	1.900 (48.3)

Dimensions in inches (millimeters) and are subject to change without notice.

CONNECTOR DESIGNATOR:

H MIL-DTL-38999, Series III and IV
EN3645

Finish

N = Electroless Nickel

W = 1,000 Hr. Cadmium Olive Drab
over Electroless Nickel

X = Aluminum, Nickel Fluorocarbon Polymer

Z = Aluminum, Zinc-Nickel, Black

M85049/78

- 10

W

01

Basic
Part Number

Shell Size
(Tables I & II)

Clamp Size
(Tables II & III)

TABLE I: Shell Size,
Thread and Dimensions

Shell Size	A Thread Class 2B	B Dia Max
09	M12 X 1 - 6H	.750 (19.1)
11	M15 X 1 - 6H	.850 (21.6)
13	M18 X 1 - 6H	1.000 (25.4)
15	M22 X 1 - 6H	1.150 (29.2)
17	M25 X 1 - 6H	1.250 (31.8)
19	M28 X 1 - 6H	1.400 (35.6)
21	M31 X 1 - 6H	1.550 (39.4)
23	M34 X 1 - 6H	1.650 (41.9)
25	M37 X 1 - 6H	1.850 (47.0)

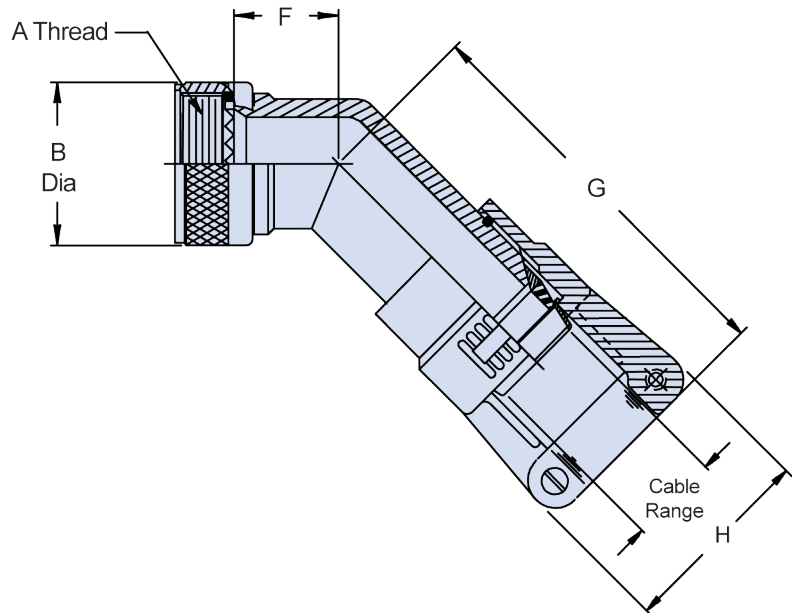

TABLE II: Shell Size,
Clamp Size and Dimensions

Shell Size	Clamp Size		F ±.062 (1.6)	G ±.062 (1.6)
	Min	Max		
09	01	02	.398 (10.1)	3.088 (78.4)
11	01	03	.458 (11.6)	3.148 (80.0)
13	02	04	.518 (13.2)	3.208 (81.5)
15	02	05	.588 (14.9)	3.298 (83.8)
17	02	06	.678 (17.2)	3.408 (86.6)
19	03	07	.868 (22.0)	3.598 (91.4)
21	03	08	.868 (22.0)	3.598 (91.4)
23	03	09	.958 (24.3)	3.748 (95.2)
25	04	10	.958 (24.3)	3.748 (95.2)

APPLICATION NOTES

- For complete dimensions see the applicable Military Specification.
- Metric dimensions (mm) are in parentheses.
- Cable Range is defined as the accommodation range for the wire bundle or cable. Dimensions shown are not intended for inspection criteria.

TABLE III: Clamp Size,
Cable Range and Dimensions

Clamp Size	Cable Range		H Max
	Min	Max	
01	.062 (1.6)	.125 (3.2)	.800 (20.3)
02	.125 (3.2)	.250 (6.4)	1.000 (25.4)
03	.250 (6.4)	.375 (9.5)	1.100 (27.9)
04	.375 (9.5)	.500 (12.7)	1.200 (30.5)
05	.500 (12.7)	.625 (15.9)	1.250 (31.8)
06	.625 (15.9)	.750 (19.1)	1.400 (35.6)
07	.750 (19.1)	.875 (22.2)	1.500 (38.1)
08	.875 (22.2)	1.000 (25.4)	1.650 (41.9)
09	1.000 (25.4)	1.125 (28.6)	1.750 (44.5)
10	1.125 (28.6)	1.250 (31.8)	1.900 (48.3)

Dimensions in inches (millimeters) and are subject to change without notice.

AS85049/79 90° EMI/RFI Environmental Backshell



AS85049

CONNECTOR DESIGNATOR:	
H	MIL-DTL-38999, Series III and IV EN3645

N = Electroless Nickel	Finish
W = 1,000 Hr. Cadmium Olive Drab over Electroless Nickel	X = Aluminum, Nickel Fluorocarbon Polymer
	Z = Aluminum, Zinc-Nickel, Black

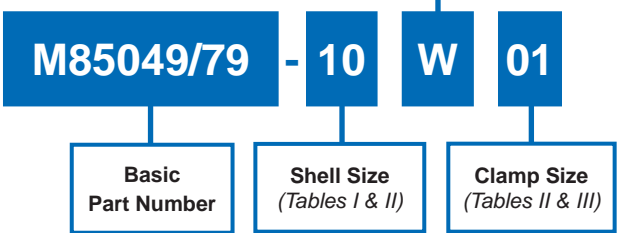
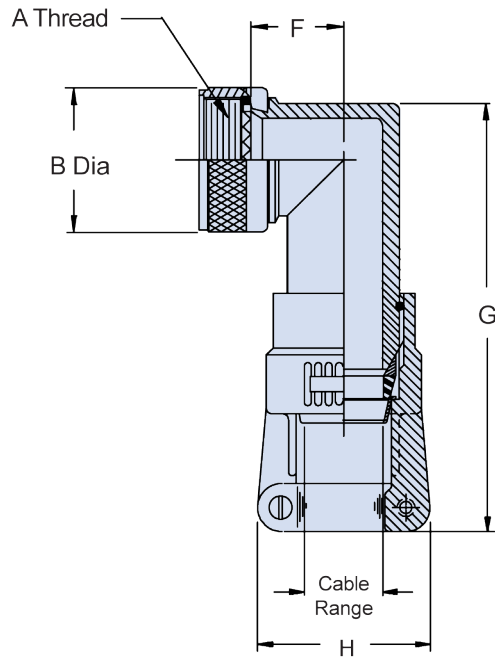

TABLE I: Shell Size, Thread and Dimensions		
Shell Size	A Thread Class 2B	B Dia Max
09	M12 X 1 - 6H	.750 (19.1)
11	M15 X 1 - 6H	.850 (21.6)
13	M18 X 1 - 6H	1.000 (25.4)
15	M22 X 1 - 6H	1.150 (29.2)
17	M25 X 1 - 6H	1.250 (31.8)
19	M28 X 1 - 6H	1.400 (35.6)
21	M31 X 1 - 6H	1.550 (39.4)
23	M34 X 1 - 6H	1.650 (41.9)
25	M37 X 1 - 6H	1.850 (47.0)

TABLE II: Shell Size, Clamp Size and Dimensions				
Shell Size	Clamp Size		F ±.156 (4.0)	G ±.188 (4.8)
	Min	Max		
09	01	02	.532 (13.5)	3.267 (83.0)
11	01	03	.627 (15.9)	3.387 (86.0)
13	02	04	.642 (16.3)	3.407 (86.5)
15	02	05	.719 (18.3)	3.477 (88.3)
17	02	06	.774 (19.7)	3.567 (90.6)
19	03	07	.854 (21.7)	3.737 (94.9)
21	03	08	.899 (22.8)	3.737 (94.9)
23	03	09	1.009 (25.6)	3.847 (97.7)
25	04	10	1.024 (26.0)	3.847 (97.7)



- APPLICATION NOTES**
- For complete dimensions see the applicable Military Specification.
 - Metric dimensions (mm) are in parentheses.
 - Cable Range is defined as the accommodation range for the wire bundle or cable. Dimensions shown are not intended for inspection criteria.

TABLE III: Clamp Size, Cable Range and Dimensions			
Clamp Size	Cable Range		H Max
	Min	Max	
01	.062 (1.6)	.125 (3.2)	.800 (20.3)
02	.125 (3.2)	.250 (6.4)	1.000 (25.4)
03	.250 (6.4)	.375 (9.5)	1.100 (27.9)
04	.375 (9.5)	.500 (12.7)	1.200 (30.5)
05	.500 (12.7)	.625 (15.9)	1.250 (31.8)
06	.625 (15.9)	.750 (19.1)	1.400 (35.6)
07	.750 (19.1)	.875 (22.2)	1.500 (38.1)
08	.875 (22.2)	1.000 (25.4)	1.650 (41.9)
09	1.000 (25.4)	1.125 (28.6)	1.750 (44.5)
10	1.125 (28.6)	1.250 (31.8)	1.900 (48.3)

Dimensions in inches (millimeters) and are subject to change without notice.

Basic
Part Number

Dash
Number

M85049/80 - 16

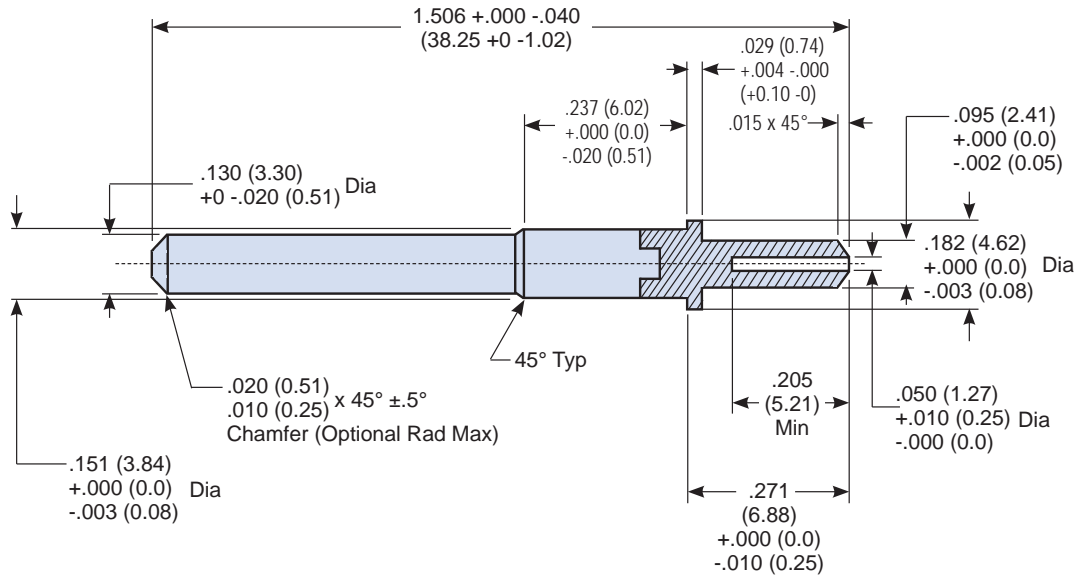

Dimensions and Configuration for Size 12 Contacts

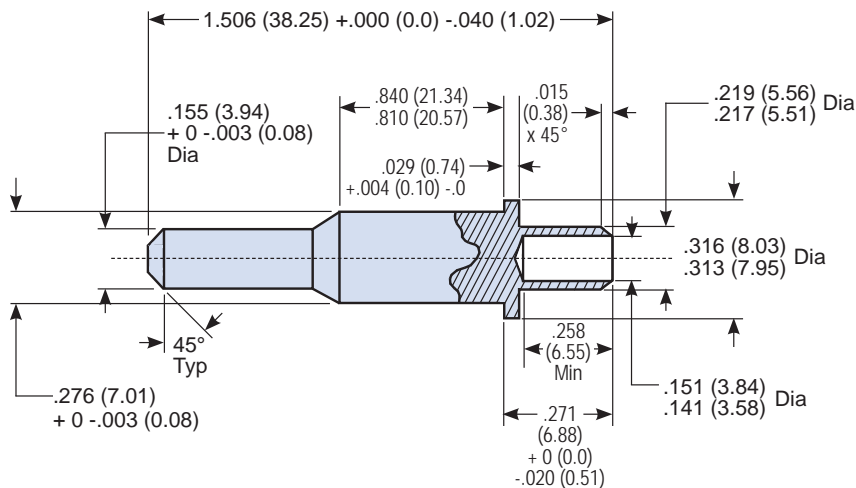

Dimensions and Configuration for Size 8 Contacts

Dimensions in inches (millimeters) and are subject to change without notice.

AS85049/80 Sealing Plug for MIL-DTL-38999 Connectors Contact Sizes 8, 12 and 16



AS85049

B

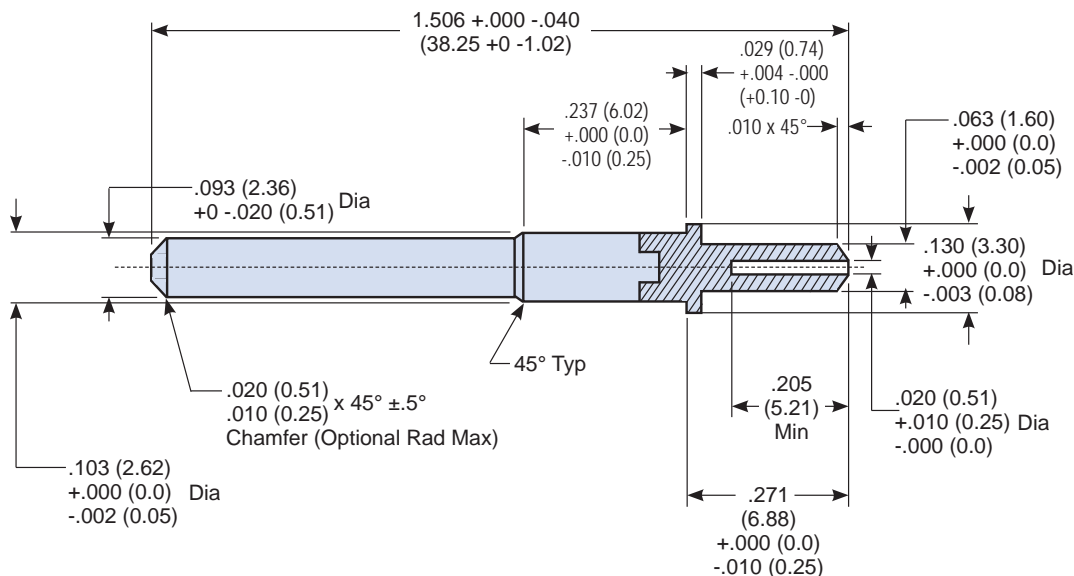

Dimensions and Configuration for Size 16 Contacts



Figure 1



Figure 2



Figure 3

Table I: Insertion and Removal Tools

Figure	Size	Type	Glenair Part Number	Military Part Number
1	#16	Insertion/Extraction	809-131	M81969/14-03
2	#12	Insertion/extraction	809-132	M81969/14-04
3	#8	Extraction only	859-022	M81969/14-06

APPLICATION NOTES

1. Assembly identified with manufacturer's name and part number, space permitting.
2. Color:
Size 16 - Blue, IAW EIA RS359
Size 12 - Yellow, IAW EIA RS359
Size 8 - Green, IAW EIA RS359
3. Insulation resistance: 100 megaohms minimum at 500V DC when tested IAW EIA 364-21, using flat probes placed on opposite ends of the dummy contact.
4. Size 16 is for use in MIL-DTL-Series I, III or IV connectors in size 16 contact cavities. Size 12 is for use in MIL-DTL-38999 Series I, III or IV connectors in size 12 contact cavities. Size 8 is for use in MIL-DTL-38999 Series I, III or IV connectors in size 8 cavities.
5. Sizes 16, 12 and 8 dummy contacts are to be used in lieu of contacts and sealing plugs in unwired contact cavities for both pin and socket inserts.
6. The size 8 dummy contact requires an additional boot (to be provided by the connector manufacturer) for insert arrangements 17-2, 19-18, 21-75, 25-7, 25-8, 25-46 and 25-90 to seal the cavity.
7. For complete dimensions, see the applicable Military Specification.
8. Metric dimensions (mm) are in parentheses.

Dimensions in inches (millimeters) and are subject to change without notice.

Basic
Part NumberDash
Number
M85049/81 - 10

B

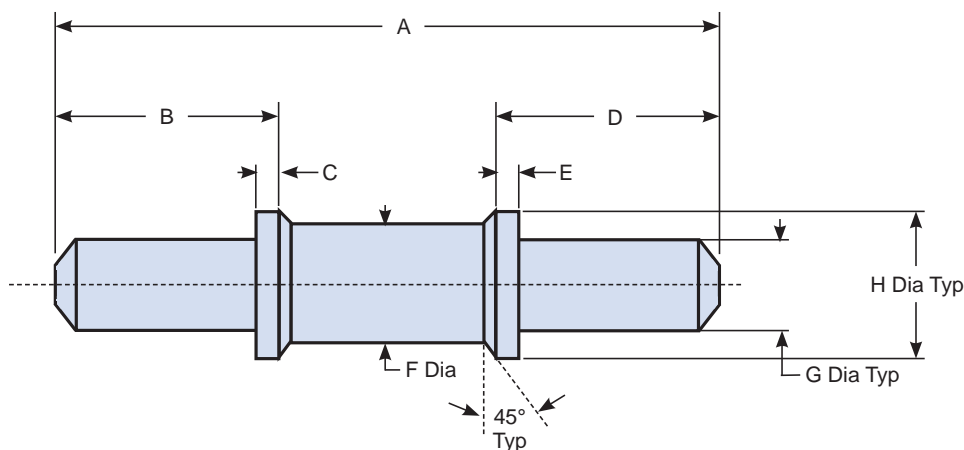

TABLE I: Dimensions

Dash No.	A Dim	B Dim	C Dim	D Dim	E Dim	F Dia	G Dia	H Dia
10	.702 (17.83) .672 (17.07)	.255 (6.48) .245 (6.22)	.034 (0.86) .028 (0.71)	.255 (6.48) .245 (6.22)	.034 (0.86) .028 (0.71)	.155 (3.94) .149 (3.78)	.130 (3.30) .120 (3.05)	.185 (4.70) .179 (4.55)

APPLICATION NOTES

1. Assembly identified with manufacturer's name and part number, space permitting.
2. Material and color:
Green polytetrafluoroethylene, perfluoroalkoxy (PFA) or fluorinated ethylene propylene (FEP) rod, molded or extruded, temperature limit 200°C minimum.
3. Insulation resistance: 100 megaohms minimum at 500V DC when tested IAW EIA 364-21, using flat probes placed on opposite ends of the sealing plug.
4. Tool: Size 10 insertion and removal tool, military part number M81969/14-05.
5. Designed for use with MIL-DTL-38999 connectors utilizing size 10 contact cavities for AS39029/56 and /58 contacts. Sealing plug to be used in both pin and socket cavities.
6. For complete dimensions, see the applicable Military Specification.
7. Metric dimensions (mm) are in parentheses.

Dimensions in inches (millimeters) and are subject to change without notice.

AS85049/82, AS85049/83 and AS85049/84 Straight, 45° and 90° Banding Backshells with Self-Locking Coupling



AS85049

B

CONNECTOR DESIGNATOR:	
A	AS50151 Series AS34001
	MIL-DTL-26482 Series II
	AS81703 Series III
	MIL-DTL-83723 Series I and III
	40M39569, DEF 5326-3, EN 2997, EN 3646
	ESC 10, ESC 11, LN 29504
	NFC93422 Series HE302
	PAN 6432-1, PAN 6432-2, PATT 602

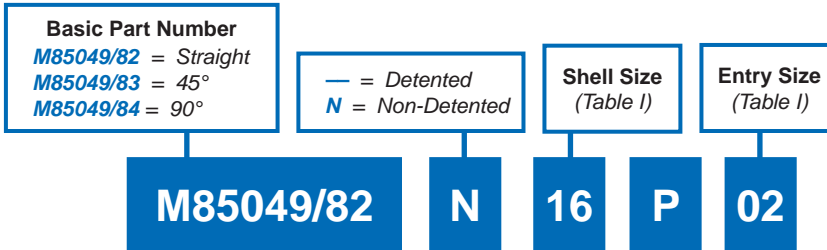

Finish
<i>N</i> = Electroless Nickel
<i>P</i> = Cadmium, Olive Drab over Electroless Nickel with Polysulfide Sealant Strips
<i>W</i> = 1,000 Hr. Cadmium Olive Drab over Electroless Nickel
<i>X</i> = Aluminum, Nickel Fluorocarbon Polymer
<i>YP</i> = Aluminum, Pure Dense Electrodeposited Aluminum with Polysulfide Sealant Strips
<i>Z</i> = Aluminum, Zinc-Nickel, Black
<i>ZP</i> = Aluminum, Zinc Nickel with Polysulfide Sealant Strips

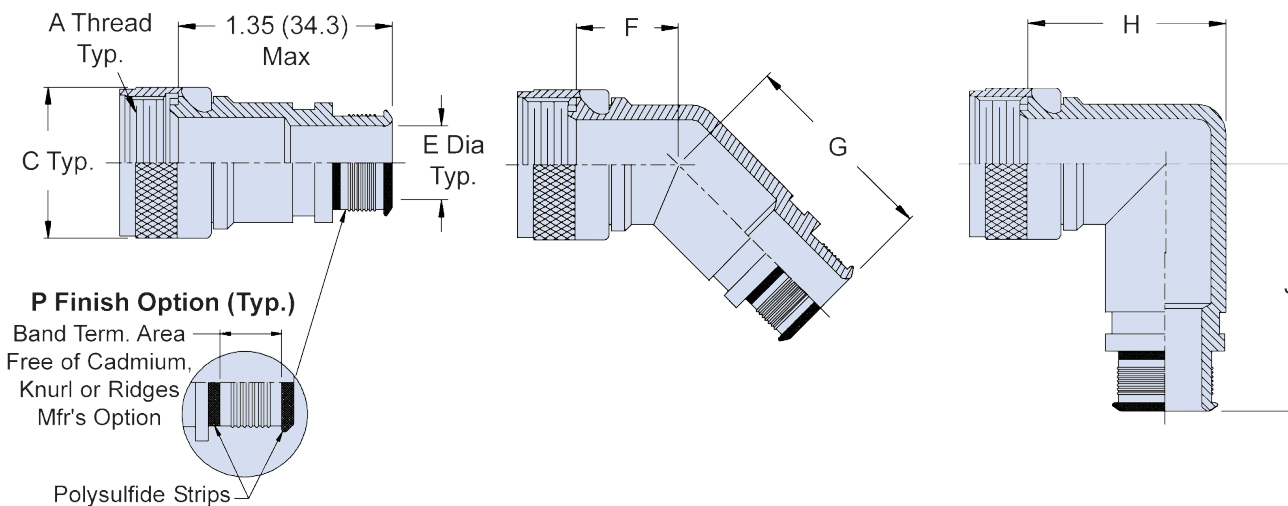

APPLICATION NOTES
1. Assembly identified with manufacturer's name and part number, space permitting.
2. For complete dimensions, see the applicable Military Specification.
3. Metric dimensions (mm) are in parentheses.
4. For use with AS85049/128 Bands.

Dimensions in inches (millimeters) and are subject to change without notice.



AS85049/82, AS85049/83 and AS85049/84 Straight, 45° and 90° Banding Backshells with Self-Locking Coupling

TABLE I: Shell Size, Cable Entry and Backshell Dimensions

Shell Size	A Thread Class 2B	C Dia Max	E Dia Cable Entry Size 02 ±.010 (0.30)	E Dia Cable Entry Size 03 ±.010 (0.30)	F Max	G Max	H Max	J Max
08	.500 - 20 UNF	.886 (22.4)	N/A	.250 (6.4)	.870 (22.1)	1.160 (29.5)	1.188 (30.2)	1.417 (36.0)
10	.625 - 24 UNEF	1.010 (25.7)	N/A	.312 (7.9)	.890 (22.6)	1.180 (30.0)	1.281 (32.5)	1.480 (37.6)
12	.750 - 20 UNEF	1.130 (28.7)	.312 (7.9)	.438 (11.1)	.920 (23.4)	1.200 (30.5)	1.406 (35.7)	1.542 (39.2)
14	.875 - 20 UNEF	1.260 (32.0)	.438 (11.1)	.562 (14.3)	.940 (23.9)	1.220 (31.0)	1.531 (38.9)	1.605 (40.8)
16	1.000 - 20 UNEF	1.386 (35.1)	.500 (12.7)	.625 (15.9)	.960 (24.4)	1.250 (31.8)	1.656 (42.1)	1.667 (42.3)
18	1.062 - 18 UNEF	1.510 (38.4)	.625 (15.9)	.750 (19.1)	.980 (24.9)	1.260 (32.0)	1.718 (43.6)	1.730 (43.9)
20	1.188 - 18 UNEF	1.636 (41.4)	.625 (15.9)	.812 (20.6)	1.00 (25.4)	1.290 (32.8)	1.844 (46.8)	1.792 (45.5)
22	1.313 - 18 UNEF	1.760 (44.7)	.688 (17.5)	.938 (23.8)	1.030 (26.2)	1.310 (33.3)	1.938 (49.2)	1.850 (47.0)
24	1.438 - 18 UNEF	1.886 (47.8)	.750 (19.1)	1.000 (25.4)	1.050 (26.7)	1.340 (34.0)	2.093 (53.2)	1.917 (48.7)
28	1.750 - 18 UNS	2.136 (54.1)	.875 (22.2)	1.125 (28.6)	1.100 (27.9)	1.380 (35.1)	2.531 (64.3)	2.042 (51.9)

Dimensions in inches (millimeters) and are subject to change without notice.

AS85049/85, AS85049/86 and AS85049/87 Straight, 45° and 90° Banding Backshells with Self-Locking Coupling



AS85049

CONNECTOR DESIGNATOR:	
F	MIL-DTL-38999 Series I and II

Basic Part Number M85049/85 = Straight M85049/86 = 45° M85049/87 = 90°	— = Detented N = Non-Detented	Shell Size (Table I)	Entry Size (Table I)
M85049/85	N	16	P
			02

Finish
N = Electroless Nickel
P = Cadmium, Olive Drab over Electroless Nickel with Polysulfide Sealant Strips
W = 1,000 Hr. Cadmium Olive Drab over Electroless Nickel
X = Aluminum, Nickel Fluorocarbon Polymer
YP = Aluminum, Pure Dense Electrodeposited Aluminum with Polysulfide Sealant Strips
Z = Aluminum, Zinc-Nickel, Black
ZP = Aluminum, Zinc Nickel with Polysulphide Sealant Strips

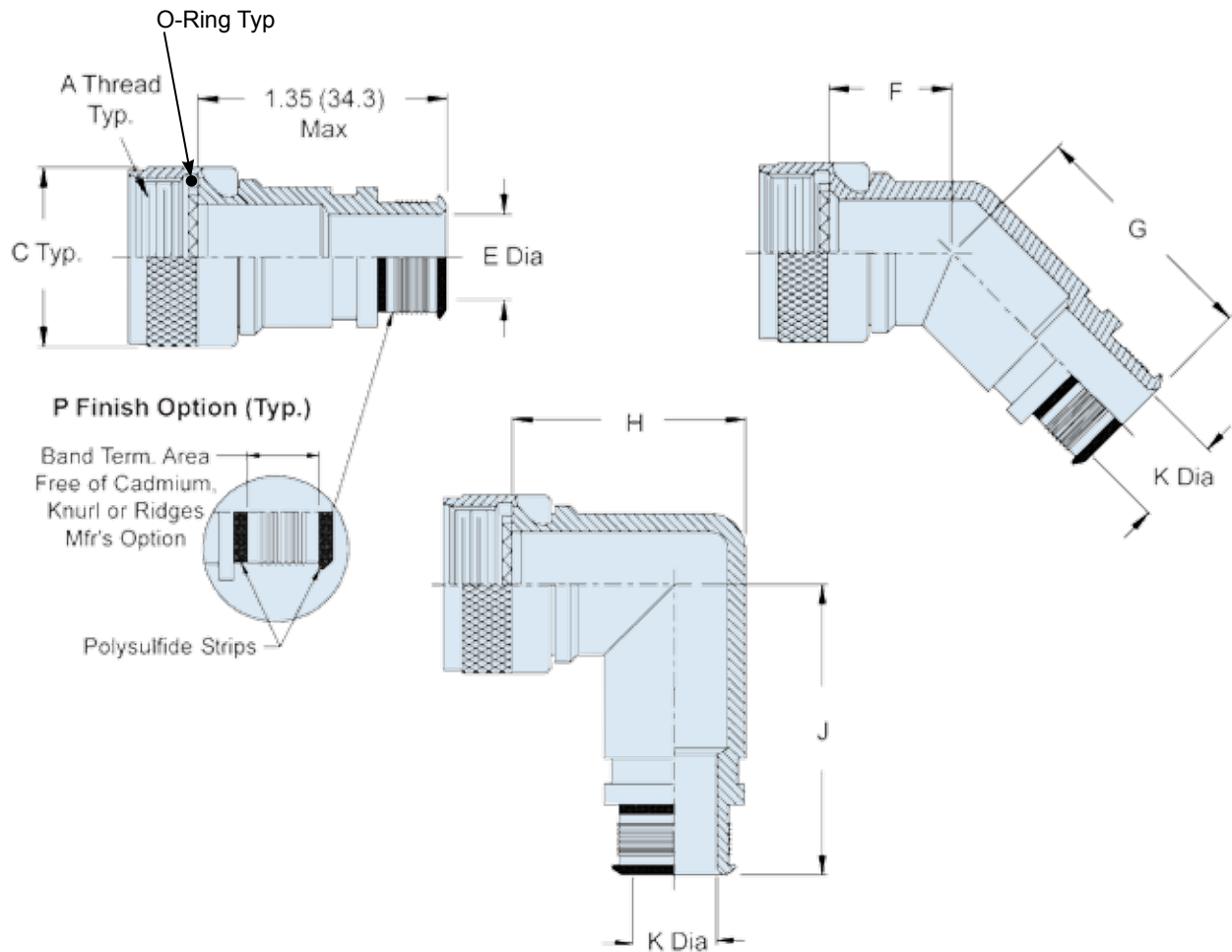

Dimensions in inches (millimeters) and are subject to change without notice.

© 2013 Glennair, Inc.

U.S. CAGE Code 06324

Printed in U.S.A.

B



AS85049/85, AS85049/86 and AS85049/87 Straight, 45° and 90° Banding Backshells with Self-Locking Coupling

TABLE I: Shell Size, Cable Entry and Backshell Dimensions

Shell Size	A Thread Class 2B	C Dia Max	F Max	G Max	H Max	J Max
08	.438 - 28 UNEF	.860 (21.8)	.870 (22.1)	1.160 (29.5)	1.375 (34.9)	1.375 (34.9)
10	.562 - 24 UNEF	.990 (25.1)	.900 (22.9)	1.190 (30.2)	1.437 (36.5)	1.437 (36.5)
12	.688 - 24 UNEF	1.160 (29.5)	.920 (23.4)	1.210 (30.7)	1.562 (39.7)	1.562 (39.7)
14	.813 - 20 UNEF	1.280 (32.5)	.950 (24.1)	1.240 (31.5)	1.687 (42.8)	1.687 (42.8)
16	.938 - 20 UNEF	1.410 (35.8)	.980 (24.9)	1.260 (32.0)	1.750 (44.5)	1.750 (44.5)
18	1.063 - 18 UNEF	1.520 (38.6)	.980 (24.9)	1.270 (32.3)	1.875 (47.6)	1.875 (47.6)
20	1.188 - 18 UNEF	1.640 (41.7)	1.010 (25.7)	1.300 (33.0)	1.938 (49.2)	1.938 (49.2)
22	1.313 - 18 UNEF	1.770 (45.0)	1.040 (26.4)	1.330 (33.8)	2.062 (52.4)	2.062 (52.4)
24	1.438 - 18 UNEF	1.890 (48.0)	1.070 (27.2)	1.350 (34.3)	2.125 (54.0)	2.125 (54.0)

TABLE II: Shell Size and Cable Entry for Straight Configuration Only

Shell Size	E Dia Cable Entry Size 01 ±.010 (0.30)	E Dia Cable Entry Size 02 ±.010 (0.30)
08	N/A	.250 (6.4)
10	N/A	.312 (7.9)
12	.312 (7.9)	.438 (11.1)
14	.438 (11.1)	.562 (14.3)
16	.500 (12.7)	.625 (15.9)
18	.625 (15.9)	.750 (19.1)
20	.625 (15.9)	.812 (20.6)
22	.688 (17.5)	.938 (23.8)
24	.750 (19.1)	1.000 (25.4)

TABLE III: Shell Size and Cable Entry for 45° and 90° Configurations Only

Shell Size	K Dia Cable Entry Size 02 ±.010 (0.30)	K Dia Cable Entry Size 03 ±.010 (0.30)
08	N/A	.250 (6.4)
10	N/A	.312 (7.9)
12	.312 (7.9)	.438 (11.1)
14	.438 (11.1)	.562 (14.3)
16	.500 (12.7)	.625 (15.9)
18	.625 (15.9)	.750 (19.1)
20	.625 (15.9)	.812 (20.6)
22	.688 (17.5)	.938 (23.8)
24	.750 (19.1)	1.000 (25.4)

APPLICATION NOTES

1. Assembly identified with manufacturer's name and part number, space permitting.
2. For complete dimensions, see the applicable Military Specification.
3. Metric dimensions (mm) are in parentheses.
4. For use with AS85049/128 Bands.

Dimensions in inches (millimeters) and are subject to change without notice.

AS85049/88, AS85049/89 and AS85049/90 Straight, 45° and 90° Banding Backshells with Self-Locking Coupling



AS85049

CONNECTOR DESIGNATOR:	
H	MIL-DTL-38999 Series III and IV EN3645

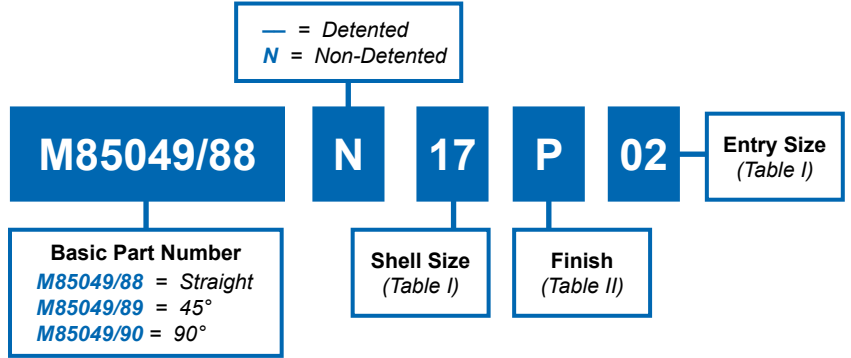

B

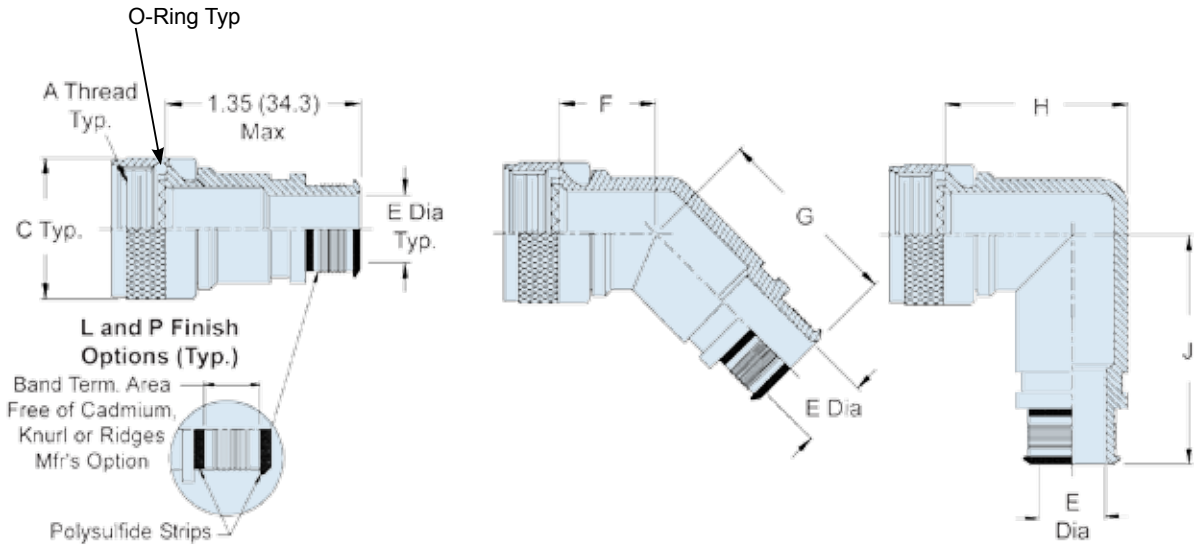

APPLICATION NOTES
1. Assembly identified with manufacturer's name and part number, space permitting.
2. For complete dimensions, see the applicable Military Specification.
3. Metric dimensions (mm) are in parentheses.
4. For use with AS85049/128 Bands.

Dimensions in inches (millimeters) and are subject to change without notice.



AS85049/88, AS85049/89 and AS85049/90 Straight, 45° and 90° Banding Backshells with Self-Locking Coupling

TABLE I: Shell Size, Cable Entry and Backshell Dimensions

Shell Size	A Thread Class 2B	C Dia Max	E Dia Cable Entry Size 02 ±.010 (0.30)	E Dia Cable Entry Size 03 ±.010 (0.30)	F Max	G Max	H Max	J Max
9	M12 X 1 - 6H	.860 (21.8)	N/A	.250 (6.4)	1.010 (25.7)	1.160 (29.5)	1.375 (34.9)	1.417 (36.0)
11	M15 X 1 - 6H	.990 (25.1)	N/A	.312 (7.9)	1.030 (26.2)	1.190 (30.2)	1.437 (36.5)	1.480 (37.6)
13	M18 X 1 - 6H	1.160 (29.5)	.312 (7.9)	.438 (11.1)	1.060 (26.9)	1.210 (30.7)	1.562 (39.7)	1.553 (39.4)
15	M22 X 1 - 6H	1.280 (32.5)	.438 (11.1)	.562 (14.3)	1.080 (27.4)	1.240 (31.5)	1.687 (42.8)	1.614 (41.0)
17	M25 X 1 - 6H	1.410 (35.8)	.500 (12.7)	.625 (15.9)	1.110 (28.2)	1.260 (32.0)	1.750 (44.5)	1.678 (42.6)
19	M28 X 1 - 6H	1.520 (38.6)	.625 (15.9)	.750 (19.1)	1.120 (28.4)	1.270 (32.3)	1.875 (47.6)	1.733 (44.0)
21	M31 X 1 - 6H	1.640 (41.7)	.625 (15.9)	.812 (20.6)	1.150 (29.2)	1.300 (33.0)	1.938 (49.2)	1.796 (45.6)
23	M34 X 1 - 6H	1.770 (45.0)	.688 (17.5)	.938 (23.8)	1.170 (29.7)	1.330 (33.8)	2.062 (52.4)	1.859 (47.2)
25	M37 X 1 - 6H	1.890 (48.0)	.750 (19.1)	1.000 (25.4)	1.200 (30.5)	1.350 (34.3)	2.125 (54.0)	1.919 (48.7)

TABLE II: Finish and Material

Aluminum	Composite	Finish Description
G	Not Available	Electroless Nickel (Space Grade)
N	M	Electroless Nickel
P	L	Cadmium Olive Drab over Electroless Nickel, Selective Plating
W	J	Cadmium Olive Drab
X	XC	Nickel Fluorocarbon Polymer
YP	YL	Pure Dense Electrodeposited Aluminum, Selective Plating
Z	ZC	Zinc Nickel
ZP	ZL	Zinc Nickel, Selective Plating

Dimensions in inches (millimeters) and are subject to change without notice.

AS85049/91 and AS85049/92 Composite Strain Reliefs Self-Locking



AS85049

B

CONNECTOR DESIGNATOR:

H MIL-DTL-38999 Series III & IV,
EN3645

Material and Finish Designator

J = Composite (Conductive), Cadmium Olive Drab over Electroless Nickel
M = Composite (Conductive) Electroless Nickel
T = Composite (Non-Conductive) without Plating
XC = Composite (Conductive) Nickel Fluorocarbon Polymer
YC = Composite (Conductive) Pure Dense Electrodeposited Aluminum
ZC = Composite (Conductive) Zinc-Nickel, Black

Basic Part Number
M85049/91 = Straight
M85049/92 = 90°

M85049/92

N

11

T

-- = Detented
N = Non-Detented

Shell Size

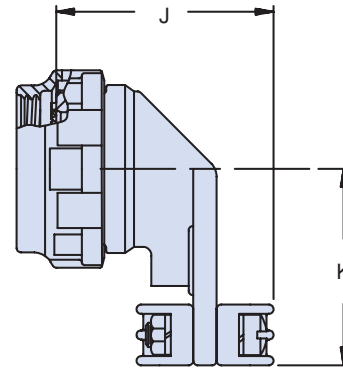
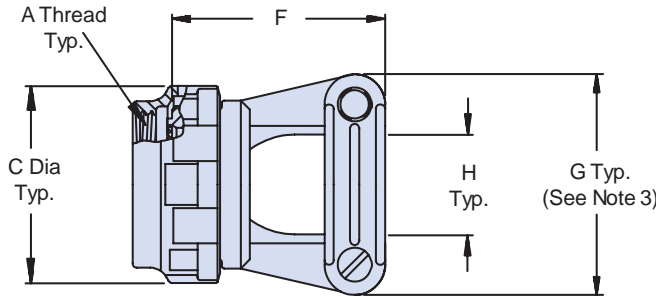

TABLE I: Shell Size, Cable Entry and Backshell Dimensions

Shell Size	A Thread Class 2B	Ø C Max		F Max		G Max		Ø H +.031		J Max		K	
											±.062	(1.6)	
09	M12 X 1 - 6H	.858	(21.8)	.840	(21.3)	.98	(24.9)	.219	(5.6)	1.06	(26.9)	.875	(22.2)
11	M15 X 1 - 6H	.984	(25.0)	.960	(24.4)	1.05	(26.7)	.264	(6.7)	1.10	(27.9)	.937	(23.8)
13	M18 X 1 - 6H	1.157	(29.4)	1.100	(27.9)	1.20	(30.5)	.344	(8.7)	1.18	(30.0)	1.031	(26.2)
15	M22 X 1 - 6H	1.280	(32.5)	1.100	(27.9)	1.30	(33.0)	.460	(11.7)	1.30	(33.0)	1.125	(28.6)
17	M25 X 1 - 6H	1.406	(35.7)	1.230	(31.2)	1.42	(36.1)	.545	(13.8)	1.38	(35.1)	1.312	(33.3)
19	M28 X 1 - 6H	1.516	(38.5)	1.410	(35.8)	1.52	(38.6)	.615	(15.6)	1.45	(36.8)	1.375	(34.9)
21	M31 X 1 - 6H	1.642	(41.7)	1.510	(38.4)	1.64	(41.7)	.698	(17.7)	1.54	(39.1)	1.500	(38.1)
23	M34 X 1 - 6H	1.768	(44.9)	1.660	(42.2)	1.77	(45.0)	.700	(17.8)	1.62	(41.1)	1.625	(41.3)
25	M37 X 1 - 6H	1.890	(48.0)	1.760	(44.7)	1.89	(48.0)	.850	(21.6)	1.69	(42.9)	1.750	(44.5)

APPLICATION NOTES

1. Assembly to be identified with manufacturer's name and part number, space permitting.
2. Cable Entry is measured with saddle bars closed and bottomed on clamp ears.
3. For complete dimensions, see the applicable Military Specification.
4. Metric dimensions (mm) are in parentheses.

Dimensions in inches (millimeters) and are subject to change without notice.

Basic
Part Number

Dash No.

M85049/93 - 10

B

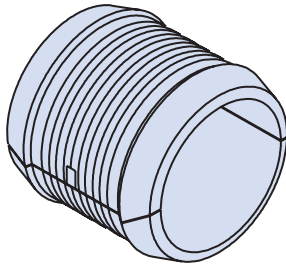

SAMPLE APPLICATION

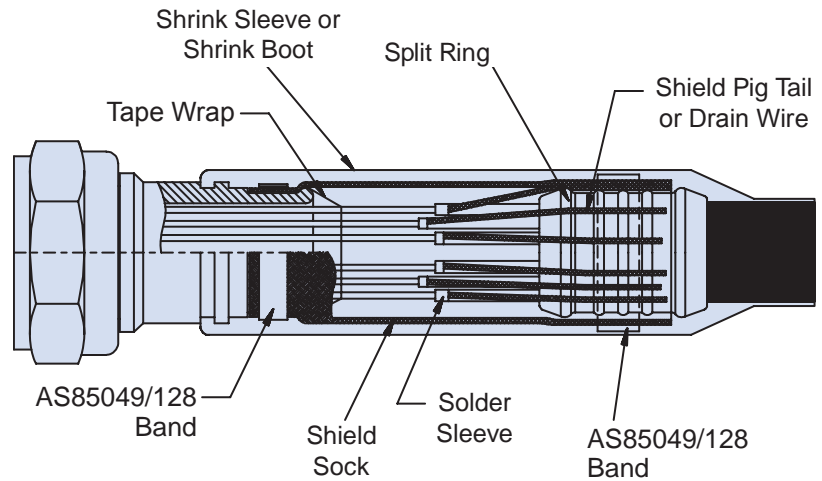
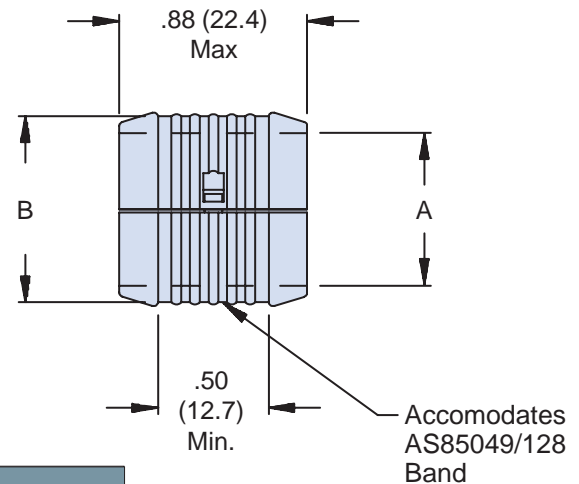

TABLE I: Reference for Connector Shell Size

Dash No.	Ø A		Ø B	
	±.010	(0.3)	±.030	(0.8)
04	.25	(6.4)	.36	(9.1)
06	.38	(9.7)	.49	(12.4)
08	.50	(12.7)	.61	(15.5)
10	.63	(16.0)	.74	(18.8)
12	.75	(19.1)	.86	(21.8)
14	.88	(22.4)	.99	(25.1)
16	1.00	(25.4)	1.11	(28.2)
18	1.13	(28.7)	1.24	(31.5)
20	1.25	(31.8)	1.36	(34.5)
22	1.38	(35.1)	1.49	(37.8)
24	1.50	(38.1)	1.61	(40.9)
26	1.63	(41.4)	1.74	(44.2)
28	1.75	(44.5)	1.86	(47.2)



APPLICATION NOTES

1. Assembly identified with manufacturer's name and part number, space permitting.
2. For complete dimensions, see the applicable Military Specification.
3. Use with Glenair Banding Backshells and Braid Socks. Consult factory for specific application part numbers.
4. Metric dimensions (mm) are in parentheses.
5. Material - high grade engineering thermoplastic.

Dimensions in inches (millimeters) and are subject to change without notice.

AS85049/94 Mounting Flange, Full Perimeter



AS85049

B

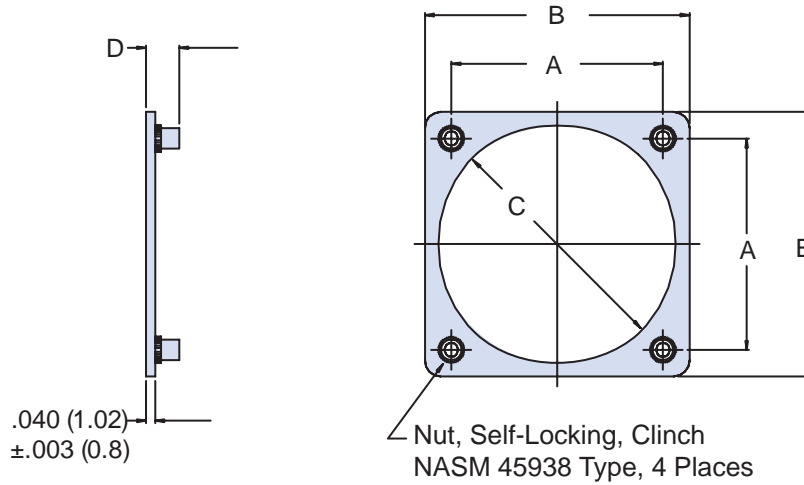
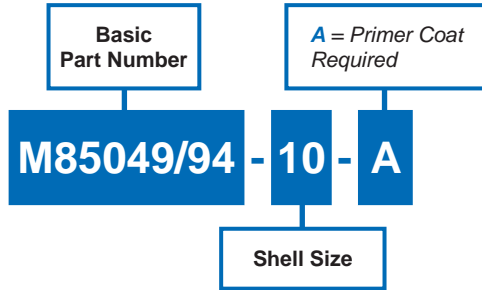

TABLE I: Reference for Connector Shell Size

Shell Size	Thread UNJC-3B	A		B Max		C		D Max	
		±.015	(.38)			±.015	(.4)		
8	4-40	.594	(15.1)	.900	(22.9)	.570	(14.5)	.166	(4.2)
10	4-40	.719	(18.3)	1.034	(26.3)	.720	(18.3)	.166	(4.2)
12	4-40	.812	(20.6)	1.119	(28.4)	.845	(21.5)	.166	(4.2)
14	4-40	.906	(23.0)	1.213	(30.8)	.975	(24.8)	.166	(4.2)
16	4-40	.969	(24.6)	1.295	(32.9)	1.085	(27.6)	.166	(4.2)
18	4-40	1.062	(27.0)	1.421	(36.1)	1.210	(30.7)	.166	(4.2)
20	4-40	1.156	(29.4)	1.550	(39.4)	1.335	(33.9)	.166	(4.2)
22	4-40	1.250	(31.8)	1.680	(42.7)	1.470	(37.3)	.166	(4.2)
24	6-32	1.375	(34.9)	1.800	(45.7)	1.585	(40.3)	.183	(4.6)
25	6-32	1.500	(38.1)	1.910	(48.5)	1.658	(42.1)	.183	(4.6)

- APPLICATION NOTES**
1. Assembly identified with manufacturer's name and part number, space permitting.
 2. For complete dimensions, see the applicable Military Specification.
 3. Metric dimensions (mm) are in parentheses.

Dimensions in inches (millimeters) and are subject to change without notice.

Basic
Part Number

A = Primer Coat
Required

M85049/95 - 10A - A

Shell Size
and Class

APPLICATION NOTES

1. Assembly identified with manufacturer's name and part number, space permitting.
2. For complete dimensions, see the applicable Military Specification.
3. Metric dimensions (mm) are in parentheses.

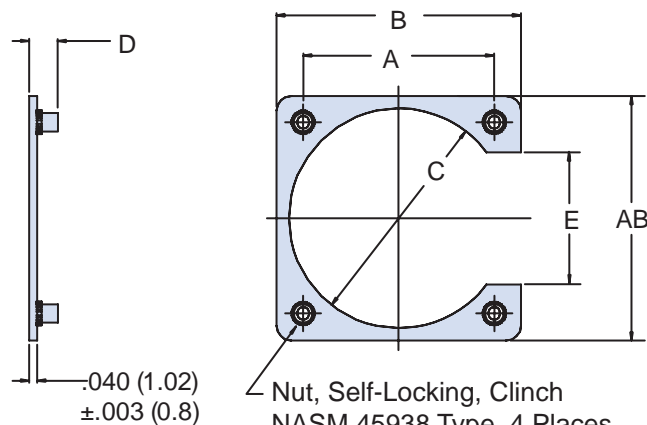

TABLE I: Reference for Connector Shell Size

Shell Size & Class	Thread UNJC-3B	A ±.003 (0.1)		B ±.015 (0.4)		C ±.015 (0.4)		D Max		E ±.030 (0.8)	
3A	4-40	.625	(15.9)	.925	(23.5)	.641	(16.3)	.166	(4.2)	.325	(8.3)
7A	4-40	.719	(18.3)	1.019	(25.9)	.688	(17.5)	.166	(4.2)	.433	(11.0)
8A	4-40	.594	(15.1)	.880	(22.4)	.570	(14.5)	.166	(4.2)	.308	(7.8)
10A	4-40	.719	(18.3)	1.019	(25.9)	.720	(18.3)	.166	(4.2)	.433	(11.0)
10B	6-32	.812	(20.6)	1.312	(33.3)	.749	(19.0)	.183	(4.6)	.433	(11.0)
12A	4-40	.812	(20.6)	1.104	(28.0)	.855	(21.7)	.166	(4.2)	.530	(13.5)
12B	6-32	.938	(23.8)	1.312	(33.3)	.938	(23.8)	.183	(4.6)	.530	(13.5)
14A	4-40	.906	(23.0)	1.198	(30.4)	.984	(25.0)	.166	(4.2)	.624	(15.8)
14B	6-32	1.031	(26.2)	1.406	(35.7)	1.031	(26.2)	.183	(4.6)	.624	(15.8)
16A	4-40	.969	(24.6)	1.280	(32.5)	1.094	(27.8)	.166	(4.2)	.687	(17.4)
16B	6-32	1.125	(28.6)	1.500	(38.1)	1.125	(28.6)	.183	(4.6)	.687	(17.4)
18A	4-40	1.062	(27.0)	1.406	(35.7)	1.220	(31.0)	.166	(4.2)	.780	(19.8)
18B	6-32	1.203	(30.6)	1.578	(40.1)	1.234	(31.3)	.183	(4.6)	.780	(19.8)
19A	4-40	.906	(23.0)	1.192	(30.3)	.953	(24.2)	.166	(4.2)	.620	(15.7)
20A	4-40	1.156	(29.4)	1.535	(39.0)	1.345	(34.2)	.166	(4.2)	.874	(22.2)
20B	6-32	1.297	(32.9)	1.688	(42.9)	1.359	(34.5)	.183	(4.6)	.865	(22.0)
22A	4-40	1.250	(31.8)	1.665	(42.3)	1.478	(37.5)	.166	(4.2)	.968	(24.6)
22B	6-32	1.375	(34.9)	1.738	(44.1)	1.483	(37.7)	.183	(4.6)	.907	(23.0)
24A	6-32	1.500	(38.1)	1.891	(48.0)	1.560	(39.6)	.183	(4.6)	1.000	(25.4)
24B	6-32	1.375	(34.9)	1.785	(45.3)	1.595	(40.5)	.183	(4.6)	1.031	(26.2)
25A	6-32	1.500	(38.1)	1.891	(48.0)	1.658	(42.1)	.183	(4.6)	1.125	(28.6)
27A	4-40	.969	(24.6)	1.255	(31.9)	1.094	(27.8)	.166	(4.2)	.683	(17.3)
28A	6-32	1.562	(39.7)	2.000	(50.8)	1.820	(46.2)	.183	(4.6)	1.125	(28.6)
32A	6-32	1.750	(44.5)	2.312	(58.7)	2.062	(52.4)	.183	(4.6)	1.188	(30.2)
36A	6-32	1.938	(49.2)	2.500	(63.5)	2.312	(58.7)	.183	(4.6)	1.375	(34.9)
37A	4-40	1.187	(30.1)	1.500	(38.1)	1.281	(32.5)	.166	(4.2)	.874	(22.2)
61A	4-40	1.437	(36.5)	1.812	(46.0)	1.594	(40.5)	.166	(4.2)	1.602	(40.7)

Dimensions in inches (millimeters) and are subject to change without notice.

AS85049/96 Mounting Flange, 1/4 Perimeter



AS85049

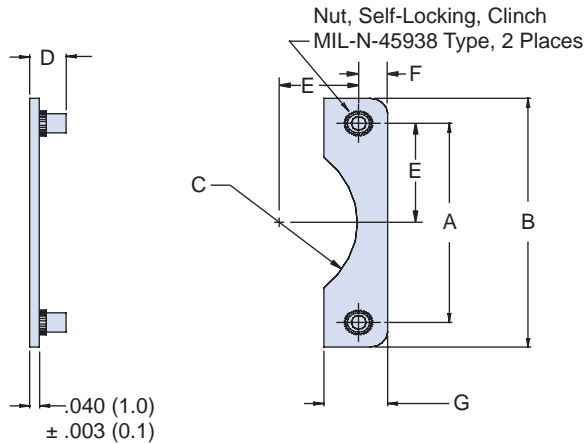
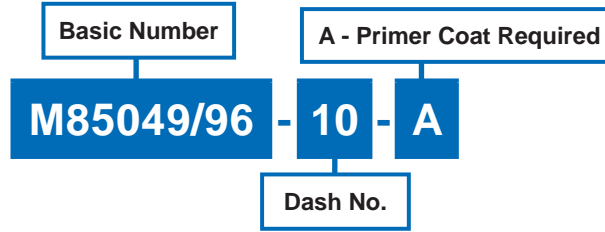

TABLE I

Dash No.	Thread UNJC-3B	A ± .003 (0.1)	B ± .015 (0.4)	C + .015 (.4) - .000 (.0)	D ± .030 (0.8)	E ± .005 (0.1)	F (Ref)	G Max
3	4-40	.625 (15.9)	.925 (23.5)	.300 (7.6)	.136 (3.5)	.312 (7.92)	.150 (3.81)	.310 (7.87)
7	4-40	.719 (18.3)	1.016 (25.8)	.298 (7.6)	.136 (3.5)	.359 (9.12)	.149 (3.78)	.308 (7.82)
8	4-40	.594 (15.1)	.891 (22.6)	.296 (7.5)	.136 (3.5)	.297 (7.54)	.148 (3.76)	.306 (7.77)
10	4-40	.719 (18.3)	1.016 (25.8)	.298 (7.6)	.136 (3.5)	.359 (9.12)	.149 (3.78)	.308 (7.82)
12	4-40	.812 (20.6)	1.109 (28.2)	.296 (7.5)	.136 (3.5)	.406 (10.31)	.148 (3.76)	.306 (7.77)
14	4-40	.906 (23.0)	1.203 (30.6)	.296 (7.5)	.136 (3.5)	.453 (11.51)	.148 (3.76)	.306 (7.77)
16	4-40	.969 (24.6)	1.266 (32.2)	.298 (7.6)	.136 (3.5)	.484 (12.29)	.149 (3.78)	.308 (7.82)
18	4-40	1.062 (27.0)	1.390 (35.3)	.328 (8.3)	.136 (3.5)	.531 (13.49)	.164 (4.17)	.338 (8.59)
19	4-40	.906 (23.0)	1.203 (30.6)	.296 (7.5)	.136 (3.5)	.453 (11.51)	.148 (3.76)	.306 (7.77)
20	4-40	1.156 (29.4)	1.510 (38.4)	.354 (9.0)	.136 (3.5)	.578 (14.68)	.177 (4.50)	.364 (9.25)
22	4-40	1.250 (31.8)	1.640 (41.7)	.390 (9.9)	.136 (3.5)	.625 (15.88)	.195 (4.95)	.400 (10.16)
24	6-32	1.375 (34.9)	1.760 (44.7)	.386 (9.8)	.153 (3.9)	.687 (17.45)	.193 (4.90)	.396 (10.06)
25	6-32	1.500 (38.1)	1.859 (47.2)	.358 (9.1)	.153 (3.9)	.750 (19.05)	.179 (4.55)	.368 (9.35)
27	4-40	.969 (24.6)	1.266 (32.2)	.298 (7.6)	.136 (3.5)	.484 (12.29)	.149 (3.78)	.308 (7.82)
28	6-32	1.562 (39.7)	2.000 (50.8)	.438 (11.1)	.153 (3.9)	.781 (19.84)	.219 (5.56)	.448 (11.38)
32	6-32	1.750 (44.5)	2.312 (58.7)	.562 (14.3)	.153 (3.9)	.875 (22.23)	.281 (7.14)	.572 (14.53)
36	6-32	1.938 (49.2)	2.500 (63.5)	.562 (14.3)	.153 (3.9)	.969 (24.61)	.281 (7.14)	.572 (14.53)
37	4-40	1.187 (30.1)	1.500 (38.1)	.314 (8.0)	.136 (3.5)	.593 (15.06)	.157 (3.99)	.324 (8.23)
61	4-40	1.437 (36.5)	1.812 (46.0)	.376 (9.6)	.136 (3.5)	.718 (18.24)	.188 (4.78)	.386 (9.80)

Dimensions in inches (millimeters) and are subject to change without notice.

B

AS85049/103

Composite Straight RFI/EMI Shield-Sock Adapter with Detented or Non-Detented Self-Locking Coupling Nut

CONNECTOR DESIGNATOR:
H MIL-DTL-38999 Series III and IV
EN3645

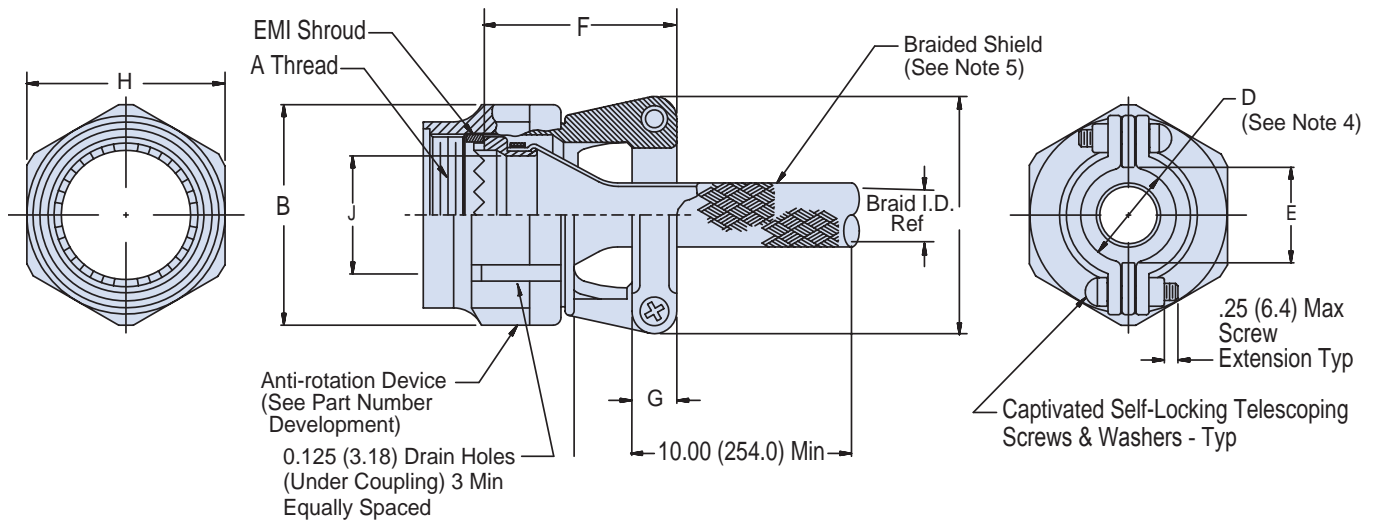
**Product Series and
Basic Part Number**
**Shell Size
(Table I)**
M85049/103 - 11 N
**N = Non-Detented Self-Locking
(Omit for Detented Self-Locking)
(See Note 6)**

APPLICATION NOTES

- For complete dimensions see the applicable Military Specification.
- Metric dimensions (mm) are in parentheses.
- Glenair 600 Series backshell assembly tools are recommended for assembly and installation.
- Cable entry is measured with saddle bars closed and bottomed on clamp ears.
- For shield/splice termination use AS85049/93 split support ring.
- Detented self-locking has a positive audible detented coupling.
- Material/Finish:
Clamp body, coupling nut, saddles - High grade engineering thermoplastic/N.A.
Clamp hardware - CRES/passivated, silver plated, mfg option
Anti-rotation device - Corrosion resistant material
Braid - Copper/nickel plated
Interface ring and shroud - Brass/nickel plated
Braid retention device - See Table II

Dimensions in inches (millimeters) and are subject to change without notice.

AS85049/103
Composite Straight RFI/EMI Shield-Sock Adapter
with Detented or Non-Detented Self-Locking Coupling Nut



AS85049

B

TABLE I: Shell Size and Dimensions

Shell Size	A Thread Class 2B	B Max	C Max	D ± .031 (0.79) See Note 4	E Min	F Max	G ± .030 (0.76)	H Hex	J Min	Braid I.D. Ref	Screw Size
09	M12 X 1 - 6H	.858 (21.79)	.98 (24.89)	.265 (6.73)	.229 (5.82)	.939 (23.85)	.375 (9.53)	.750/.736 (19.05/18.69)	.264 (6.71)	.375 (9.53)	4-40
11	M15 X 1 - 6H	.984 (24.99)	1.05 (26.67)	.310 (7.87)	.274 (6.96)	1.059 (26.90)	.375 (9.53)	.875/.860 (22.23/21.84)	.390 (9.91)	.375 (9.53)	4-40
13	M18 X 1 - 6H	1.157 (29.39)	1.20 (30.48)	.390 (9.91)	.354 (8.99)	1.199 (30.45)	.406 (10.31)	1.000/.980 (25.40/24.89)	.504 (12.80)	.500 (12.70)	6-32
15	M22 X 1 - 6H	1.280 (32.51)	1.30 (33.02)	.506 (12.85)	.470 (11.94)	1.199 (30.45)	.406 (10.31)	1.125/1.100 (31.75/31.09)	.630 (16.00)	.500 (12.70)	6-32
17	M25 X 1 - 6H	1.406 (35.71)	1.44 (36.58)	.591 (15.01)	.555 (14.10)	1.329 (33.76)	.406 (10.31)	1.250/1.224 (31.75/31.09)	.756 (19.20)	.781 (19.84)	6-32
19	M28 X 1 - 6H	1.516 (38.51)	1.56 (39.62)	.661 (16.79)	.625 (15.88)	1.509 (38.33)	.406 (10.31)	1.375/1.348 (34.93/34.24)	.843 (21.41)	.781 (19.84)	6-32
21	M31 X 1 - 6H	1.642 (41.71)	1.69 (42.93)	.744 (18.90)	.708 (17.98)	1.609 (40.87)	.406 (10.31)	1.500/1.469 (38.10/37.31)	.969 (24.61)	1.000 (25.40)	6-32
23	M34 X 1 - 6H	1.768 (44.91)	1.77 (44.96)	.826 (20.98)	.790 (20.07)	1.759 (44.68)	.406 (10.31)	1.625/1.581 (41.28/40.16)	1.091 (27.71)	1.000 (25.40)	6-32
25	M37 X 1 - 6H	1.890 (48.01)	1.89 (48.01)	.896 (22.76)	.860 (21.84)	1.859 (47.22)	.406 (10.31)	1.750/1.690 (44.45/42.93)	1.217 (30.91)	1.250 (31.75)	6-32

Table II (Manufacturer's Option)

Material	Finish
Aluminum Alloy	Iridite per AMS-C-5541
Stainless Steel	Passivated
Copper	Tin Plate

Dimensions in inches (millimeters) and are subject to change without notice.

© 2013 Glenair, Inc.

U.S. CAGE Code 06324

Printed in U.S.A.

AS85049/104

Composite 45° RFI/EMI Shield-Sock Adapter with Detented or Non-Detented Self-Locking Coupling Nut

CONNECTOR DESIGNATOR:
H MIL-DTL-38999 Series III and IV
EN3645

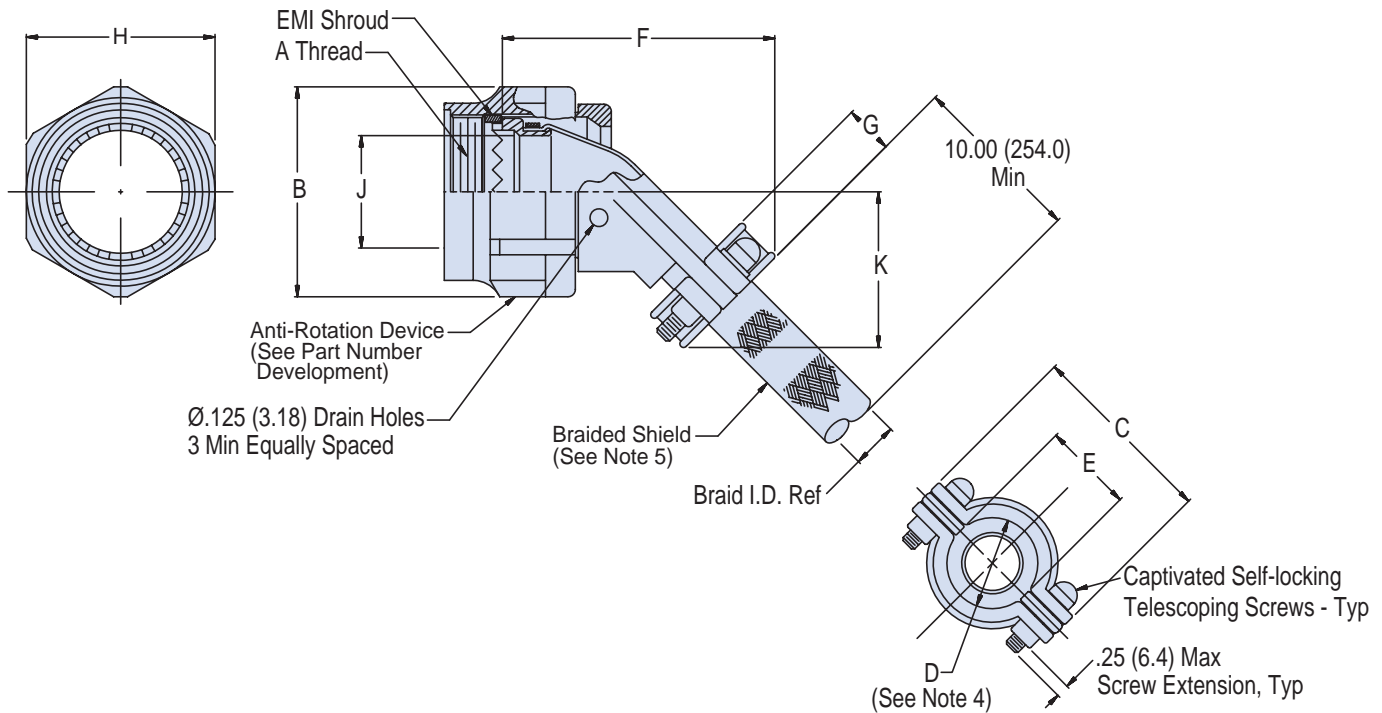
**Product Series and
Basic Part Number**
**Shell Size
(Table I)**
M85049/104 - 11 N
**N = Non-Detented Self-Locking
(Omit for Detented Self-Locking)
(See Note 6)**

APPLICATION NOTES

- For complete dimensions see the applicable Military Specification.
- Metric dimensions (mm) are in parentheses.
- Glenair 600 Series backshell assembly tools are recommended for assembly and installation.
- Cable entry is measured with saddle bars closed and bottomed on clamp ears.
- For shield/splice termination use AS85049/93 split support ring.
- Detented self-locking has a positive audible detented coupling.
- Material/Finish:
Clamp body, coupling nut, saddles - High grade engineering thermoplastic/N.A.
Clamp hardware - CRES/passivated, silver plated, mfg option
Anti-rotation device - Corrosion resistant material
Braid - Copper/nickel plated
Interface ring and shroud - Brass/nickel plated
Braid retention device - See Table II

Dimensions in inches (millimeters) and are subject to change without notice.

AS85049/104
Composite 45° RFI/EMI Shield-Sock Adapter
with Detented or Non-Detented Self-Locking Coupling Nut



AS85049

B

TABLE I: Shell Size and Dimensions

Shell Size	A Thread Class 2B	B Max	C Max	D ± .031 (0.79) See Note 4	E Min	F Max	G ± .030 (0.76)	H Hex	J Min	K Max	Braid I.D. Ref	Screw Size
09	M12 X 1 - 6H	.858 (21.79)	.98 (24.89)	.265 (6.73)	.229 (5.82)	1.388 (35.26)	.375 (9.53)	.750/.736 (19.05/18.69)	.264 (6.71)	.901 (22.89)	.375 (9.53)	4-40
11	M15 X 1 - 6H	.984 (24.99)	1.05 (26.67)	.310 (7.87)	.274 (6.96)	1.428 (36.27)	.375 (9.53)	.875/.860 (22.23/21.84)	.390 (9.91)	.964 (24.39)	.375 (9.53)	4-40
13	M18 X 1 - 6H	1.157 (29.39)	1.20 (30.48)	.390 (9.91)	.354 (8.99)	1.498 (38.05)	.406 (10.31)	1.000/.980 (25.40/24.89)	.504 (12.80)	1.050 (26.67)	.500 (12.70)	6-32
15	M22 X 1 - 6H	1.280 (32.51)	1.30 (33.02)	.506 (12.85)	.470 (11.94)	1.548 (39.32)	.406 (10.31)	1.125/1.100 (31.75/31.09)	.630 (16.00)	1.112 (28.24)	.500 (12.70)	6-32
17	M25 X 1 - 6H	1.406 (35.71)	1.44 (36.58)	.591 (15.01)	.555 (14.10)	1.648 (41.86)	.406 (10.31)	1.250/1.224 (31.75/31.09)	.756 (19.20)	1.175 (29.85)	.781 (19.84)	6-32
19	M28 X 1 - 6H	1.516 (38.51)	1.56 (39.62)	.661 (16.79)	.625 (15.88)	1.768 (44.91)	.406 (10.31)	1.375/1.348 (34.93/34.24)	.843 (21.41)	1.230 (31.24)	.781 (19.84)	6-32
21	M31 X 1 - 6H	1.642 (41.71)	1.69 (42.93)	.744 (18.90)	.708 (17.98)	1.808 (45.92)	.406 (10.31)	1.500/1.469 (38.10/37.31)	.969 (24.61)	1.293 (32.84)	1.000 (25.40)	6-32
23	M34 X 1 - 6H	1.768 (44.91)	1.77 (44.96)	.826 (20.98)	.790 (20.07)	1.858 (47.19)	.406 (10.31)	1.625/1.581 (41.28/40.16)	1.091 (27.71)	1.365 (34.67)	1.000 (25.40)	6-32
25	M37 X 1 - 6H	1.890 (48.01)	1.89 (48.01)	.896 (22.76)	.860 (21.84)	1.898 (48.21)	.406 (10.31)	1.750/1.690 (44.45/42.93)	1.217 (30.91)	1.417 (35.99)	1.250 (31.75)	6-32

Table II (Manufacturer's Option)

Material	Finish
Aluminum Alloy	Iridite per AMS-C-5541
Stainless Steel	Passivated
Copper	Tin Plate

Dimensions in inches (millimeters) and are subject to change without notice.

© 2013 Glenair, Inc.

U.S. CAGE Code 06324

Printed in U.S.A.

AS85049/105

Composite 90° RFI/EMI Shield-Sock Adapter with Detented or Non-Detented Self-Locking Coupling Nut

CONNECTOR DESIGNATOR:

H MIL-DTL-38999 Series III and IV
EN3645

Product Series and
Basic Part Number

Shell Size
(Table I)

M85049/105 - 11 N

*N = Non-Detented Self-Locking
(Omit for Detented Self-Locking)
(See Note 6)*

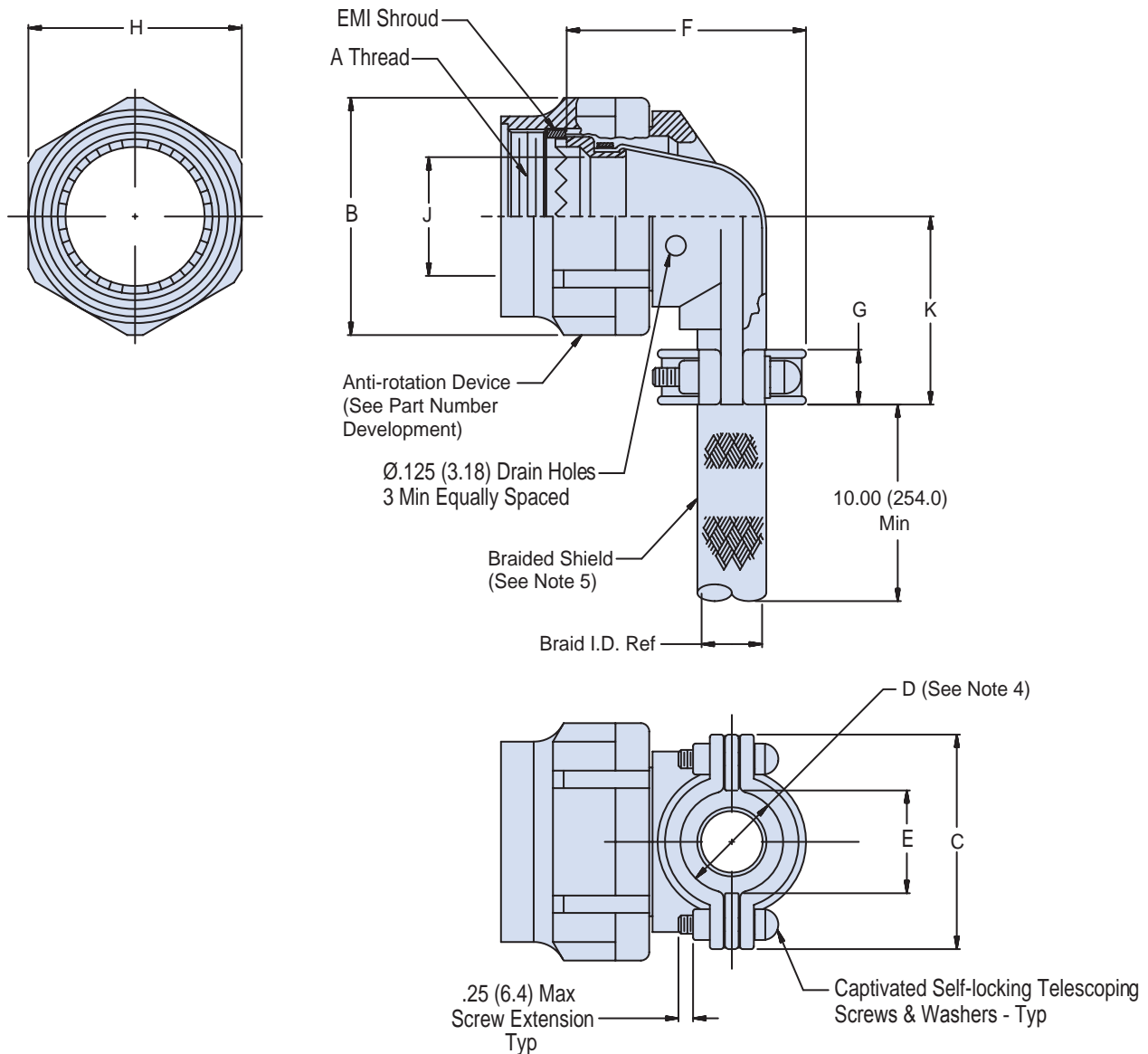

Dimensions in inches (millimeters) and are subject to change without notice.

AS85049/105
Composite 90° RFI/EMI Shield-Sock Adapter
with Detented or Non-Detented Self-Locking Coupling Nut



AS85049

B

TABLE I: Shell Size and Dimensions

Shell Size	A Thread Class 2B	B Max	C Max	D ± .031 (0.79) See Note 4	E Min	F Max	G ± .030 (0.76)	H Hex	J Min	K Max	Braid I.D. Ref	Screw Size
09	M12 X 1 - 6H	.858 (21.79)	.98 (24.89)	.265 (6.73)	.229 (5.82)	1.128 (28.65)	.375 (9.53)	.750/.736 (19.05/18.69)	.264 (6.71)	.94 (23.88)	.375 (9.53)	4-40
11	M15 X 1 - 6H	.984 (24.99)	1.05 (26.67)	.310 (7.87)	.274 (6.96)	1.168 (29.67)	.375 (9.53)	.875/.860 (22.23/21.84)	.390 (9.91)	1.00 (25.40)	.375 (9.53)	4-40
13	M18 X 1 - 6H	1.157 (29.39)	1.20 (30.48)	.390 (9.91)	.354 (8.99)	1.248 (31.70)	.406 (10.31)	1.000/.980 (25.40/24.89)	.504 (12.80)	1.12 (28.45)	.500 (12.70)	6-32
15	M22 X 1 - 6H	1.280 (32.51)	1.30 (33.02)	.506 (12.85)	.470 (11.94)	1.368 (34.75)	.406 (10.31)	1.125/1.100 (31.75/31.09)	.630 (16.00)	1.19 (30.23)	.500 (12.70)	6-32
17	M25 X 1 - 6H	1.406 (35.71)	1.44 (36.58)	.591 (15.01)	.555 (14.10)	1.448 (36.78)	.406 (10.31)	1.250/1.224 (31.75/31.09)	.756 (19.20)	1.37 (34.80)	.781 (19.84)	6-32
19	M28 X 1 - 6H	1.516 (38.51)	1.56 (39.62)	.661 (16.79)	.625 (15.88)	1.528 (38.81)	.406 (10.31)	1.375/1.348 (34.93/34.24)	.843 (21.41)	1.44 (36.58)	.781 (19.84)	6-32
21	M31 X 1 - 6H	1.642 (41.71)	1.69 (42.93)	.744 (18.90)	.708 (17.98)	1.648 (41.86)	.406 (10.31)	1.500/1.469 (38.10/37.31)	.969 (24.61)	1.56 (39.62)	1.000 (25.40)	6-32
23	M34 X 1 - 6H	1.768 (44.91)	1.77 (44.96)	.826 (20.98)	.790 (20.07)	1.688 (42.88)	.406 (10.31)	1.625/1.581 (41.28/40.16)	1.091 (27.71)	1.69 (42.93)	1.000 (25.40)	6-32
25	M37 X 1 - 6H	1.890 (48.01)	1.89 (48.01)	.896 (22.76)	.860 (21.84)	1.758 (44.65)	.406 (10.31)	1.750/1.690 (44.45/42.93)	1.217 (30.91)	1.81 (45.97)	1.250 (31.75)	6-32

Table II (Manufacturer's Option)

Material	Finish
Aluminum Alloy	Iridite per AMS-C-5541
Stainless Steel	Passivated
Copper	Tin Plate

APPLICATION NOTES

- | | |
|--|---|
| <ol style="list-style-type: none"> 1. For complete dimensions see the applicable Military Specification. 2. Metric dimensions (mm) are in parentheses. 3. Glenair 600 Series backshell assembly tools are recommended for assembly and installation. 4. Cable entry is measured with saddle bars closed and bottomed on clamp ears. 5. For shield/splice termination use AS85049/93 split support ring. | <ol style="list-style-type: none"> 6. Detented self-locking has a positive audible detented coupling. 7. Material/Finish:
 Clamp body, coupling nut, saddles - High grade engineering thermoplastic/N.A.
 Clamp hardware - CRES/passivated, silver plated, mfg option
 Anti-rotation device - Corrosion resistant material
 Braid - Copper/nickel plated
 Interface ring and shroud - Brass/nickel plated
 Braid retention device - See Table II |
|--|---|

Dimensions in inches (millimeters) and are subject to change without notice.



AS85049/109

Straight RFI/EMI Shield-Sock Metal Shrink Boot Adapter with Optional Detented or Non-Detented Self-Locking or Non-Self-Locking Coupling Nut

CONNECTOR DESIGNATOR:

A

AS50151 Series AS34001
 MIL-DTL-26482 Series II
 AS81703 Series III
 MIL-DTL-83723 Series I & III
 40M39569, DEF 5326-3
 EN 2997, EN 3646
 ESC 10, ESC 11, LN 29504
 NFC93422 Series HE302
 PAN 6432-1, PAN 6432-2
 PATT 602

B

Product Series and
Basic Part Number

M85049/109

Shell Size
(Table I)

S

Shield Finish
(Table IV)

10

Entry Size
(Table II)

T

Drain Hole
(Omit for None)

W

Entry Size
(Table II)

03

Drain Hole
(Omit for None)

6

Drain Hole
(Omit for None)

D

S = Detented, Self-Locking
 - = Non-Self-Locking (Use Dash)
 N = Non-Detented, Self-Locking

Finish
(Table III)

Braid Length
1 Inch Increments,
6" Min., 18" Max

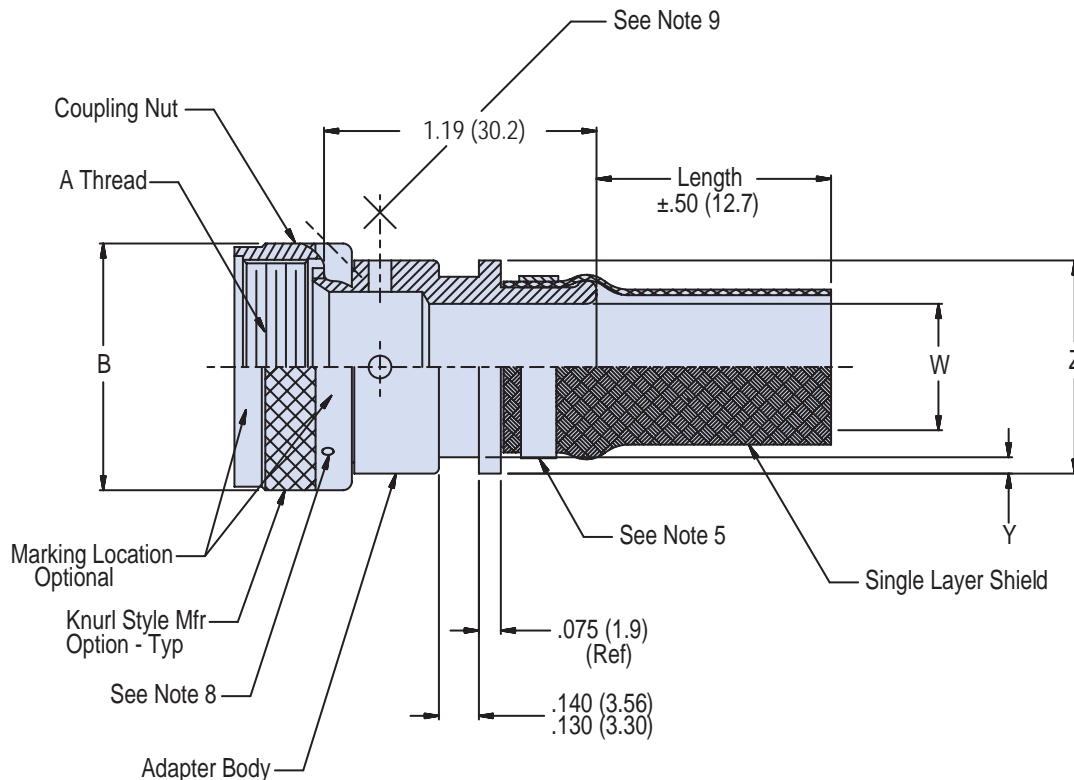

Dimensions in inches (millimeters) and are subject to change without notice.

AS85049/109
Straight RF/EMI Shield-Sock Metal
Shrink Boot Adapter with Optional Detented or Non-Detented
Self-Locking or Non-Self-Locking Coupling Nut



AS85049

B

TABLE I: Shell Size, Entry Size, Thread and Dimensions

Accessory Shell Size Code	Allowable Cable Entry Size	Shell Size AS81703, Series III (Ref)	Shell Size MIL-DTL-26482, Series II MIL-DTL-83723, Series III (Ref)	Shell Size MIL-DTL-5015, Series I and II (Ref)	A Thread Class 2B	B Max Diameter
03	01	3	-	-	9/16-24 UNEF	.855 (22.48)
08	01	-	8	8S	1/2-20 UNF	.885 (22.48)
10	01-03	-	10	10S & 10SL	5/8-24 UNEF	1.010 (25.65)
12	01-05	7	12	12S & 12	3/4-20 UNEF	1.135 (28.83)
14	02-06	12	14	14S & 14	7/8-20 UNEF	1.260 (32.00)
16	04-08	19	16	16S & 16	1-20 UNEF	1.385 (35.18)
18	05-09	27	18	18	1 1/16-18 UNEF	1.510 (38.35)
20	07-11	37	20	20	1 3/16-18 UNEF	1.635 (41.53)
22	09-13	-	22	22	1 5/16-18 UNEF	1.760 (44.70)
24	11-14	-	24	24	1 7/16-18 UNEF	1.885 (47.88)
28	14-16	-	-	28	1 3/4-18 UNS	2.135 (54.23)
32	16-17	-	-	32	2-18 UNS	2.395 (60.83)
36	17-19	-	-	36	2 1/4-16 UN	2.635 (66.93)
40	19-21	-	-	40	2 1/2-16 UN	2.885 (73.28)
44	21-23	-	-	44	2 3/4-16 UN	3.135 (76.63)
48	23-25	-	-	48	3-16 UN	3.385 (85.98)
61	12-14	61	-	-	1 1/2-18 UNEF	1.885 (47.88)

TABLE II: Entry Size and Dimensions

Entry Size	W ± .020 (.51)	Y +.008 (.20) - .000 (.00)	Z Max
01	.250 (6.4)	.044 (1.12)	.560 (14.2)
02	.312 (7.9)	.044 (1.12)	.630 (16.0)
03	.375 (9.5)	.044 (1.12)	.690 (17.5)
04	.438 (11.1)	.044 (1.12)	.750 (19.1)
05	.500 (12.7)	.044 (1.12)	.820 (20.8)
06	.562 (14.3)	.044 (1.12)	.890 (22.6)
07	.625 (15.9)	.044 (1.12)	.950 (24.1)
08	.688 (17.5)	.044 (1.12)	1.020 (25.9)
09	.750 (19.1)	.069 (1.75)	1.120 (28.4)
10	.812 (20.6)	.069 (1.75)	1.200 (30.5)
11	.875 (22.2)	.069 (1.75)	1.270 (32.3)
12	.938 (23.8)	.069 (1.75)	1.260 (32.0)
13	1.000 (25.4)	.069 (1.75)	1.370 (34.8)
14	1.125 (28.6)	.069 (1.75)	1.470 (37.3)
15	1.250 (31.8)	.069 (1.75)	1.600 (40.6)
16	1.375 (34.9)	.069 (1.75)	1.710 (43.4)
17	1.500 (38.1)	.086 (2.18)	1.840 (46.7)
18	1.625 (41.3)	.086 (2.18)	2.000 (50.8)
19	1.750 (44.5)	.086 (2.18)	2.120 (53.8)
20	1.875 (47.6)	.086 (2.18)	2.270 (57.7)
21	2.000 (50.8)	.086 (2.18)	2.440 (62.0)
22	2.125 (54.0)	.086 (2.18)	2.600 (66.0)
23	2.250 (57.2)	.086 (2.18)	2.750 (69.9)
24	2.375 (60.3)	.086 (2.18)	2.900 (73.7)
25	2.500 (63.5)	.086 (2.18)	3.060 (77.7)

Table III: Symbol and Finish

Symbol	Finish
N	Electroless Nickel
W	Cadmium/Olive Drab over Electroless Nickel (1000 Hour Salt Spray)
X	Nickel Fluorocarbon Polymer
Z	Zinc Nickel

Table IV: Symbol and Finish

Symbol	Finish
K	Nickel Plate
T	Tin Plate

Table V: (Manufacturer's Option)

Material	Finish
Copper	Tin Plate
Stainless Steel	Passivated

APPLICATION NOTES

- Metric equivalents are given for general information only and are based on 1.000 inch (25.40 mm).
- Dimensions are in inches and apply after plating. Accessory configuration is optional within the specified dimension envelope.
- Adapter length is measured from the bottom of the accessory teeth to the adapter that is covered by the braid. The adapter surface under the braid shall be ribbed knurled or have a surface roughness of .125 R minimum in accordance with ANSI B46.1.
- Pig tail terminated braid material shall be in accordance with Table IV. Braid length is defined by Note 1 as shown in the part or identifying number (PIN).
- Termination band configuration is not controlled. Band with buckle may exceed the "Z" dimension (See Table II) provided the band does not interfere with boot attachment, band material shall be specified as in Table V.
- Shrink boot (when required) shall be as specified in AS5258.
- Termination of the accessory shield with harness shield may be performed with a AS85049/93 shield support ring or similar split ring accessory types.
- Three (3) holes equally spaced shall be provided and accommodate .020 (.51) maximum safety wire for the non-self-locking coupling configuration.
- Drain holes will be provided with a .125 (3.2 mm) diameter, 4 places equally spaces (optional, see part number development).
- Material/Finish:
 Adapter, coupling nut - Al alloy/See Table III
 Band - See Table V, manufacturer's option
 Braid - Copper/See Table IV

Dimensions in inches (millimeters) and are subject to change without notice.

AS85049/111

90° RFI/EMI Shield-Sock Shrink Boot Adapter with Optional Self-Locking Coupling Nut

CONNECTOR DESIGNATOR:

A

AS50151 Series AS34001
MIL-DTL-26482 Series II
AS81703 Series III
MIL-DTL-83723 Series I & III
40M39569, DEF 5326-3
EN 2997, EN 3646
ESC 10, ESC 11, LN 29504
NFC93422 Series HE302
PAN 6432-1, PAN 6432-2
PATT 602

Product Series and
Specification Sheet

Shell Size
(Table I)

Shield Finish
(Table IV)

Entry Size
(Table II)

Drain Hole
(Omit for None)

M85049/111

S

10

T

W

03

- 6

D

S = Detented, Self-Locking
- = Non-Self-Locking (Use Dash)
N = Non-Detented, Self-Locking

Finish
(Table III)

Braid Length
1 Inch Increments,
6" Min., 18" Max

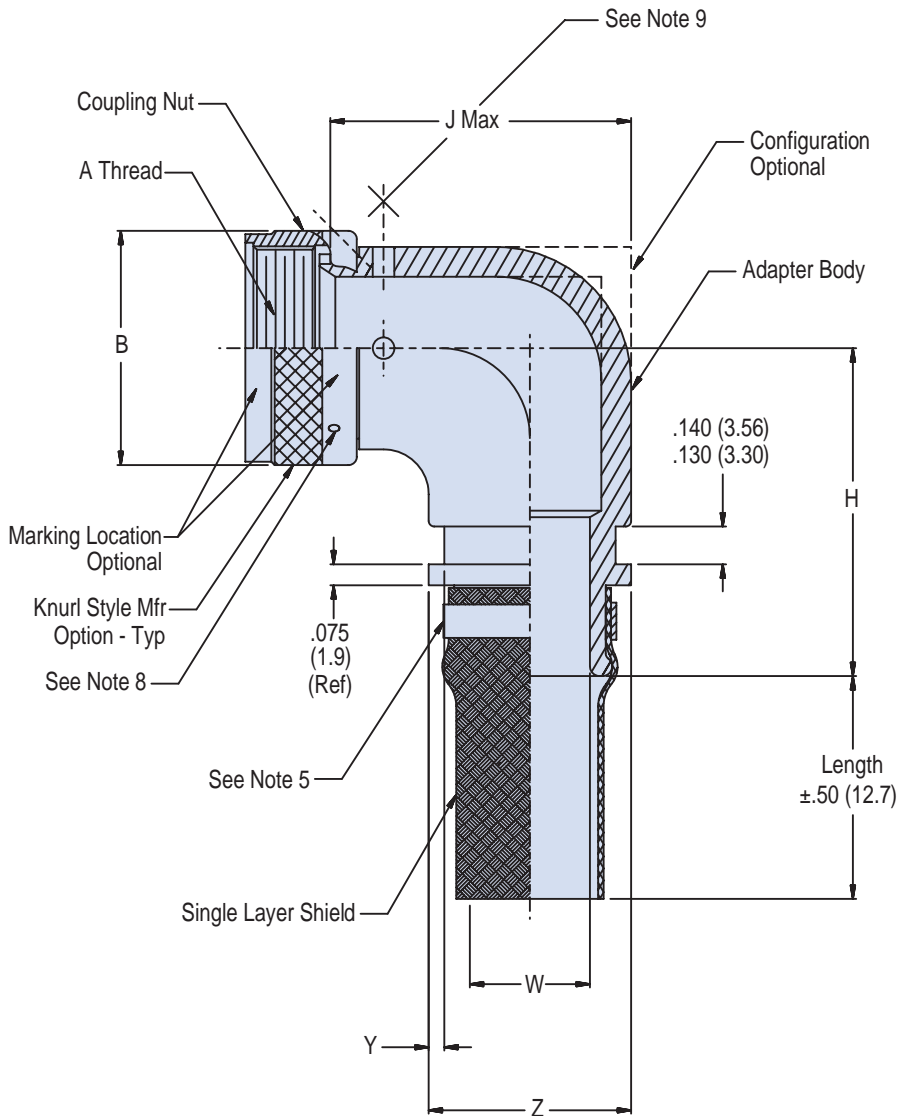

TABLE II: Entry Size and Dimensions

Entry Size	W ± .020 (.51)	Y +.008 (.20) -.000 (.00)	Z Max
01	.250 (6.4)	.044 (1.12)	.560 (14.2)
02	.312 (7.9)	.044 (1.12)	.630 (16.0)
03	.375 (9.5)	.044 (1.12)	.690 (17.5)
04	.438 (11.1)	.044 (1.12)	.750 (19.1)
05	.500 (12.7)	.044 (1.12)	.820 (20.8)
06	.562 (14.3)	.044 (1.12)	.890 (22.6)
07	.625 (15.9)	.044 (1.12)	.950 (24.1)
08	.688 (17.5)	.044 (1.12)	1.020 (25.9)
09	.750 (19.1)	.069 (1.75)	1.120 (28.4)
10	.812 (20.6)	.069 (1.75)	1.200 (30.5)
11	.875 (22.2)	.069 (1.75)	1.270 (32.3)
12	.938 (23.8)	.069 (1.75)	1.260 (32.0)
13	1.000 (25.4)	.069 (1.75)	1.370 (34.8)
14	1.125 (28.6)	.069 (1.75)	1.470 (37.3)
15	1.250 (31.8)	.069 (1.75)	1.600 (40.6)
16	1.375 (34.9)	.069 (1.75)	1.710 (43.4)
17	1.500 (38.1)	.086 (2.18)	1.840 (46.7)
18	1.625 (41.3)	.086 (2.18)	2.000 (50.8)
19	1.750 (44.5)	.086 (2.18)	2.120 (53.8)
20	1.875 (47.6)	.086 (2.18)	2.270 (57.7)
21	2.000 (50.8)	.086 (2.18)	2.440 (62.0)
22	2.125 (54.0)	.086 (2.18)	2.600 (66.0)
23	2.250 (57.2)	.086 (2.18)	2.750 (69.9)
24	2.375 (60.3)	.086 (2.18)	2.900 (73.7)
25	2.500 (63.5)	.086 (2.18)	3.060 (77.7)

Dimensions in inches (millimeters) and are subject to change without notice.

AS85049/111

90° RFI/EMI Shield-Sock Shrink Boot Adapter with Optional Self-Locking Coupling Nut



AS85049

B

TABLE I: Shell Size, Entry Size, Thread and Dimensions

Accessory Shell Size Code	Allowable Cable Entry Size	Shell Size AS81703, Series III (Ref)	Shell Size MIL-DTL-26482, Series II MIL-DTL-83723, Series III (Ref)	Shell Size MIL-DTL-5015, Series I and II (Ref)	A Thread Class 2B	B Max Diameter	H Max	J Max
03	01	3	-	-	9/16-24 UNEF	.855 (22.48)	1.730 (43.94)	1.120 (28.45)
08	01	-	8	8S	1/2-20 UNF	.885 (22.48)	1.730 (43.94)	1.120 (28.45)
10	01-03	-	10	10S & 10SL	5/8-24 UNEF	1.010 (25.65)	1.850 (46.99)	1.250 (31.75)
12	01-05	7	12	12S & 12	3/4-20 UNEF	1.135 (28.83)	1.870 (47.50)	1.380 (35.05)
14	02-06	12	14	14S & 14	7/8-20 UNEF	1.260 (32.00)	1.940 (49.28)	1.440 (36.58)
16	04-08	19	16	16S & 16	1-20 UNEF	1.385 (35.18)	2.030 (51.56)	1.560 (39.62)
18	05-09	27	18	18	1 1/16-18 UNEF	1.510 (38.35)	2.200 (55.88)	1.750 (44.45)
20	07-11	37	20	20	1 3/16-18 UNEF	1.635 (41.53)	2.200 (55.88)	1.750 (44.45)
22	09-13	-	22	22	1 5/16-18 UNEF	1.760 (44.70)	2.310 (58.67)	2.000 (50.80)
24	11-14	-	24	24	1 7/16-18 UNEF	1.885 (47.88)	2.310 (58.67)	2.000 (50.80)
28	14-16	-	-	28	1 3/4-18 UNS	2.135 (54.23)	2.480 (62.99)	2.250 (57.15)
32	16-17	-	-	32	2-18 UNS	2.395 (60.83)	2.730 (69.34)	2.750 (69.85)
36	17-19	-	-	36	2 1/4-16 UN	2.635 (66.93)	2.730 (69.34)	3.125 (79.38)
40	19-21	-	-	40	2 1/2-16 UN	2.885 (73.28)	2.880 (73.15)	4.125 (104.77)
44	21-23	-	-	44	2 3/4-16 UN	3.135 (76.63)	3.000 (76.20)	4.125 (104.77)
48	23-25	-	-	48	3-16 UN	3.385 (85.98)	3.120 (79.25)	4.125 (104.77)
61	12-14	61	-	-	1 1/2-18 UNEF	1.885 (47.88)	2.380 (60.45)	2.250 (57.15)

Table III: Symbol and Finish

Symbol	Finish
N	Electroless Nickel
W	Cadmium/Olive Drab over Electroless Nickel (1000 Hour Salt Spray)
X	Nickel Fluorocarbon Polymer
Z	Zinc Nickel

Table IV: Symbol and Finish

Symbol	Finish
K	Nickel Plate
T	Tin Plate

Table V: (Manufacturer's Option)

Material	Finish
Copper	Tin Plate
Stainless Steel	Passivated

APPLICATION NOTES

- Metric equivalents are given for general information only and are based on 1.000 inch (25.40 mm).
- Dimensions are in inches and apply after plating. Accessory configuration is optional within the specified dimension envelope.
- Adapter length is measured from the bottom of the accessory teeth to the adapter that is covered by the braid. The adapter surface under the braid shall be ribbed knurled or have a surface roughness of .125 R minimum in accordance with ANSI B46.1.
- Pig tail terminated braid material shall be in accordance with Table IV. Braid length is defined by Note 1 as shown in the part or identifying number (PIN).
- Termination band configuration is not controlled. Band with buckle may exceed the "Z" dimension (See Table II) provided the band does not interfere with boot attachment, band material shall be specified as in Table V.
- Shrink boot (when required) shall be as specified in AS5258.
- Termination of the accessory shield with harness shield may be performed with a AS85049/93 shield support ring or similar split ring accessory types.
- Three (3) holes equally spaced shall be provided and accommodate .020 (.51) maximum safety wire for the non-self-locking coupling configuration.
- Drain holes will be provided with a .125 (3.2 mm) diameter, 4 places equally spaced (optional, see part number development).
- Material/Finish:
Adapter, coupling nut - Al alloy/See Table III
Band - See Table V, manufacturer's option
Braid - Copper/See Table IV

Dimensions in inches (millimeters) and are subject to change without notice.

AS85049/112

Straight RFI/EMI Shield-Sock Shrink Boot Adapter with Optional Self-Locking Coupling Nut

CONNECTOR DESIGNATOR:

F MIL-DTL-38999 Series I and II

**Product Series and
Specification Sheet**
**Shell Size
(Table I)**
**Shield Finish
(Table IV)**
**Entry Size
(Table II)**
**Drain Hole
(Omit for None)**
M85049/112
S
10
T
W
03
- 6
D

S = Detented, Self-Locking
- = Non-Self-Locking (Use Dash)
N = Non-Detented, Self-Locking

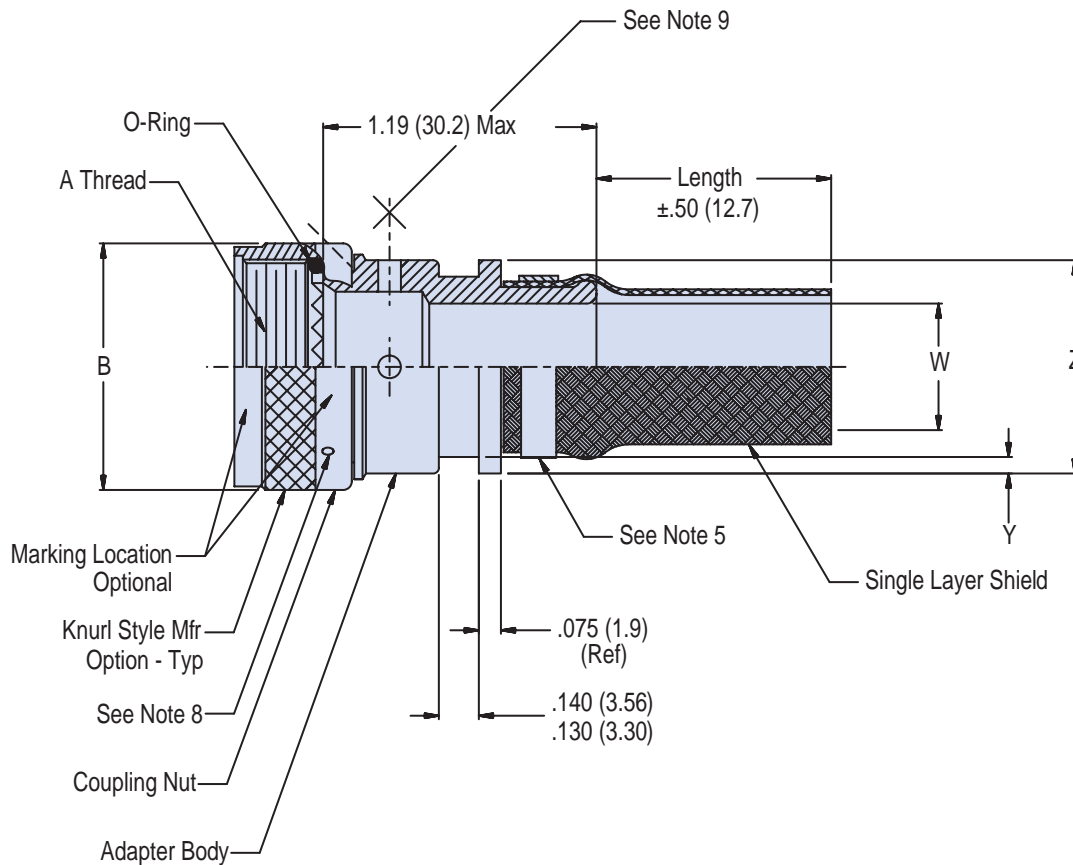
**Finish
(Table III)**
**Braid Length
1 Inch Increments,
6" Min., 18" Max**

Dimensions in inches (millimeters) and are subject to change without notice.

AS85049/112

Straight RFI/EMI Shield-Sock Shrink Boot Adapter with Optional Self-Locking Coupling Nut



AS85049

B

TABLE I: Shell Size, Entry Size, Thread and Dimensions

Accessory Shell Size Code	Series I Shell Size (Ref)	Series II Shell Size (Ref)	A Thread Class 2B	B Max Diameter	Allowable Cable Entry Size
08	9	8	7/16-28 UNEF	.858 (21.79)	01
10	11	10	9/16-24 UNEF	.984 (24.99)	01-03
12	13	12	11/16-24 UNEF	1.157 (29.39)	01-05
14	15	14	13/16-20 UNEF	1.279 (32.49)	03-07
16	17	16	15/16-20 UNEF	1.406 (35.71)	05-09
18	19	18	1 1/16-18 UNEF	1.516 (38.51)	06-10
20	21	20	1 3/16-18 UNEF	1.642 (41.71)	08-12
22	23	22	1 5/16-18 UNEF	1.768 (44.91)	09-13
24	25	24	1 7/16-18 UNEF	1.889 (47.98)	10-14

TABLE II: Entry Size and Dimensions

Entry Size	W ± .020 (.51)	Y +.008 (.20) -.000 (.00)	Z Max
01	.250 (6.4)	.044 (1.12)	.560 (14.2)
02	.312 (7.9)	.044 (1.12)	.630 (16.0)
03	.375 (9.5)	.044 (1.12)	.690 (17.5)
04	.438 (11.1)	.044 (1.12)	.750 (19.1)
05	.500 (12.7)	.044 (1.12)	.820 (20.8)
06	.562 (14.3)	.044 (1.12)	.890 (22.6)
07	.625 (15.9)	.044 (1.12)	.950 (24.1)
08	.688 (17.5)	.044 (1.12)	1.020 (25.9)
09	.750 (19.1)	.069 (1.75)	1.120 (28.4)
10	.812 (20.6)	.069 (1.75)	1.200 (30.5)
11	.875 (22.2)	.069 (1.75)	1.270 (32.3)
12	.938 (23.8)	.069 (1.75)	1.260 (32.0)
13	1.000 (25.4)	.069 (1.75)	1.370 (34.8)
14	1.125 (28.6)	.069 (1.75)	1.470 (37.3)

Table III: Symbol and Finish

Symbol	Finish
N	Electroless Nickel
W	Cadmium/Olive Drab over Electroless Nickel (1000 Hour Salt Spray)
X	Nickel Fluorocarbon Polymer
Z	Zinc Nickel

Table IV: Symbol and Finish

Symbol	Finish
K	Nickel Plate
T	Tin Plate

Table V: (Manufacturer's Option)

Material	Finish
Copper	Tin Plate
Stainless Steel	Passivated

APPLICATION NOTES

- Metric equivalents are given for general information only and are based on 1.000 inch (25.40 mm).
- Dimensions are in inches and apply after plating. Accessory configuration is optional within the specified dimension envelope.
- Adapter length is measured from the bottom of the accessory teeth to the adapter that is covered by the braid. The adapter surface under the braid shall be ribbed knurled or have a surface roughness of .125 R minimum in accordance with ANSI B46.1.
- Pig tail terminated braid material shall be in accordance with Table IV. Braid length is defined by Note 1 as shown in the part or indentifying number (PIN).
- Termination band configuration is not controlled. Band with buckle may exceed the "Z" dimension (See Table II) provided the band does not interfere with boot attachment, band material shall be specified as in Table V.
- Shrink boot (when required) shall be as specified in AS5258.
- Termination of the accessory shield with harness shield may be performed with a AS85049/93 shield support ring or similar split ring accessory types.
- Three (3) holes equally spaced shall be provided and accommodate .020 (.51) maximum safety wire for the non-self-locking coupling configuration.
- Drain holes will be provided with a .125 (3.2 mm) diameter, 4 places equally spaces (optional, see part number development). O-Ring not required when drain hole option is specified.
- Material/Finish:
 Adapter, coupling nut - Al alloy/See Table III
 Band - See Table V, manufacturer's option
 Braid - Copper/See Table IV

Dimensions in inches (millimeters) and are subject to change without notice.

AS85049/114

90° RF/EMI Shield-Sock Shrink Boot Adapter with Detented or Non-Detented Self-Locking or Non Self-Locking Coupling Nut

CONNECTOR DESIGNATOR:
F

 MIL-DTL-38999 Series I & II
 40M38277, PAN 6433-1
 PATT 614, PATT 616
 NFC93422 Series HE308 &
 HE309

 Product Series and
 Specification Sheet

 Shield Finish
 (Table IV)

 Entry Size
 (Table II)

 Drain Hole
 (Omit for None)

M85049/114
S
10
T
W
03
- 6
D
S = Detented, Self-Locking
- = Non-Self-Locking (Use Dash)
N = Non-Detented, Self-Locking

 Shell Size
 (Table I)

 Finish
 (Table III)

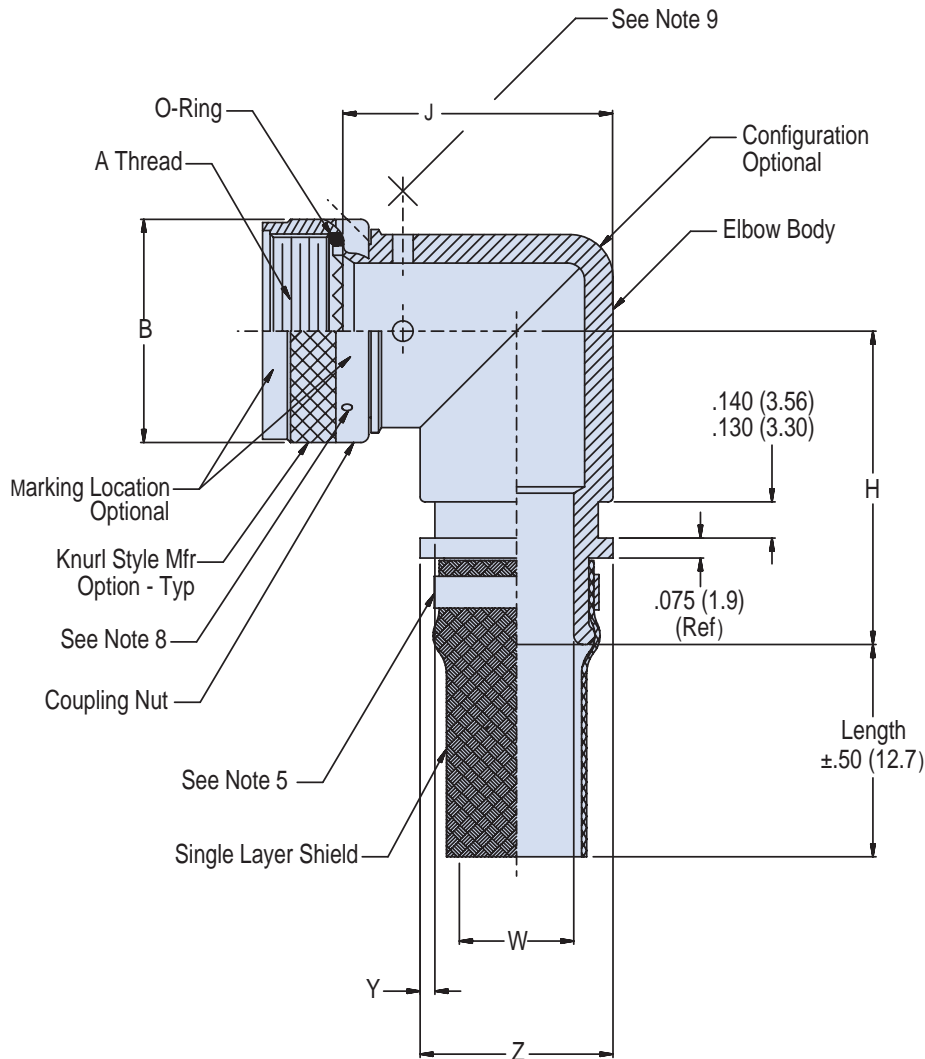
 Braid Length
 1 Inch Increments,
 6" Min., 18" Max

TABLE II: Entry Size and Dimensions

Entry Size	W ± .020 (.51)	Y +.008 (.20) -.000 (.00)	Z Max
01	.250 (6.4)	.044 (1.12)	.560 (14.2)
02	.312 (7.9)	.044 (1.12)	.630 (16.0)
03	.375 (9.5)	.044 (1.12)	.690 (17.5)
04	.438 (11.1)	.044 (1.12)	.750 (19.1)
05	.500 (12.7)	.044 (1.12)	.820 (20.8)
06	.562 (14.3)	.044 (1.12)	.890 (22.6)
07	.625 (15.9)	.044 (1.12)	.950 (24.1)
08	.688 (17.5)	.044 (1.12)	1.020 (25.9)
09	.750 (19.1)	.069 (1.75)	1.120 (28.4)
10	.812 (20.6)	.069 (1.75)	1.200 (30.5)
11	.875 (22.2)	.069 (1.75)	1.270 (32.3)
12	.938 (23.8)	.069 (1.75)	1.260 (32.0)
13	1.000 (25.4)	.069 (1.75)	1.370 (34.8)
14	1.125 (28.6)	.069 (1.75)	1.470 (37.3)

Dimensions in inches (millimeters) and are subject to change without notice.

AS85049/114
90° RF/EMI Shield-Sock Shrink Boot Adapter
with Detented or Non-Detented Self-Locking
or Non Self-Locking Coupling Nut



AS85049

B

TABLE I: Shell Size, Entry Size, Thread and Dimensions

Accessory Shell Size Code	Series I Shell Size (Ref)	Series II Shell Size (Ref)	A Thread Class 2B	B Max Diameter	H Max	J Max	Allowable Cable Entry Size
08	9	8	7/16-28 UNEF	.858 (21.79)	1.730 (43.94)	1.070 (27.18)	01
10	11	10	9/16-24 UNEF	.984 (24.99)	1.850 (46.99)	1.190 (30.23)	01-03
12	13	12	11/16-24 UNEF	1.157 (29.39)	1.870 (47.50)	1.320 (33.53)	01-05
14	15	14	13/16-20 UNEF	1.279 (32.49)	1.940 (49.28)	1.440 (36.58)	03-07
16	17	16	15/16-20 UNEF	1.406 (35.71)	2.030 (51.56)	1.570 (39.88)	05-09
18	19	18	1 1/16-18 UNEF	1.516 (38.51)	2.200 (55.88)	1.750 (44.45)	06-10
20	21	20	1 3/16-18 UNEF	1.642 (41.71)	2.200 (55.88)	1.750 (44.45)	08-12
22	23	22	1 5/16-18 UNEF	1.768 (44.91)	2.310 (58.67)	2.000 (50.80)	09-13
24	25	24	1 7/16-18 UNEF	1.889 (47.98)	2.310 (58.67)	2.000 (50.80)	10-14

Table III: Symbol and Finish

Symbol	Finish
N	Electroless Nickel
W	Cadmium/Olive Drab over Electroless Nickel (1000 Hour Salt Spray)
X	Nickel Fluorocarbon Polymer
Z	Zinc Nickel

Table IV: Symbol and Finish

Symbol	Finish
K	Nickel Plate
T	Tin Plate

Table V: (Manufacturer's Option)

Material	Finish
Copper	Tin Plate
Stainless Steel	Passivated

APPLICATION NOTES

- Metric equivalents are given for general information only and are based on 1.000 inch (25.40 mm).
- Dimensions are in inches and apply after plating. Accessory configuration is optional within the specified dimension envelope.
- Adapter length is measured from the bottom of the accessory teeth to the adapter that is covered by the braid. The adapter surface under the braid shall be ribbed knurled or have a surface roughness of .125 R minimum in accordance with ANSI B46.1.
- Pig tail terminated braid material shall be in accordance with Table IV. Braid length is defined by Note 1 as shown in the part or identifying number (PIN).
- Termination band configuration is not controlled. Band with buckle may exceed the "Z" dimension (See Table II) provided the band does not interfere with boot attachment, band material shall be specified as in Table V.
- Shrink boot (when required) shall be as specified in AS5258.
- Termination of the accessory shield with harness shield may be performed with a AS85049/93 shield support ring or similar split ring accessory types.
- Three (3) holes equally spaced shall be provided and accommodate .020 (.51) maximum safety wire for the non-self-locking coupling configuration.
- Drain holes will be provided with a .125 (3.2 mm) diameter, 4 places equally spaces (optional, see part number development). O-Ring not required when drain hole option is specified.
- Material/Finish:
 Adapter, coupling nut - Al alloy/See Table III
 Band - See Table V, manufacturer's option
 Braid - Copper/See Table IV

Dimensions in inches (millimeters) and are subject to change without notice.

AS85049/115

Straight RFI/EMI Shield-Sock Shrink Boot Adapter with Optional Self-Locking Coupling Nut

CONNECTOR DESIGNATOR:

H MIL-DTL-38999 Series III and IV
EN3645

Product Series and
Basic Part NumberShell Size
(Table I)Shield Finish
(Table IV)Entry Size
(Table II)Drain Hole
(Omit for None)**M85049/115****S****11****T****W****03****- 6****D**

S = Detented, Self-Locking
- = Non-Self-Locking (Use Dash)
N = Non-Detented, Self-Locking

Finish
(Table III)

Braid Length
1 Inch Increments,
6" Min., 18" Max

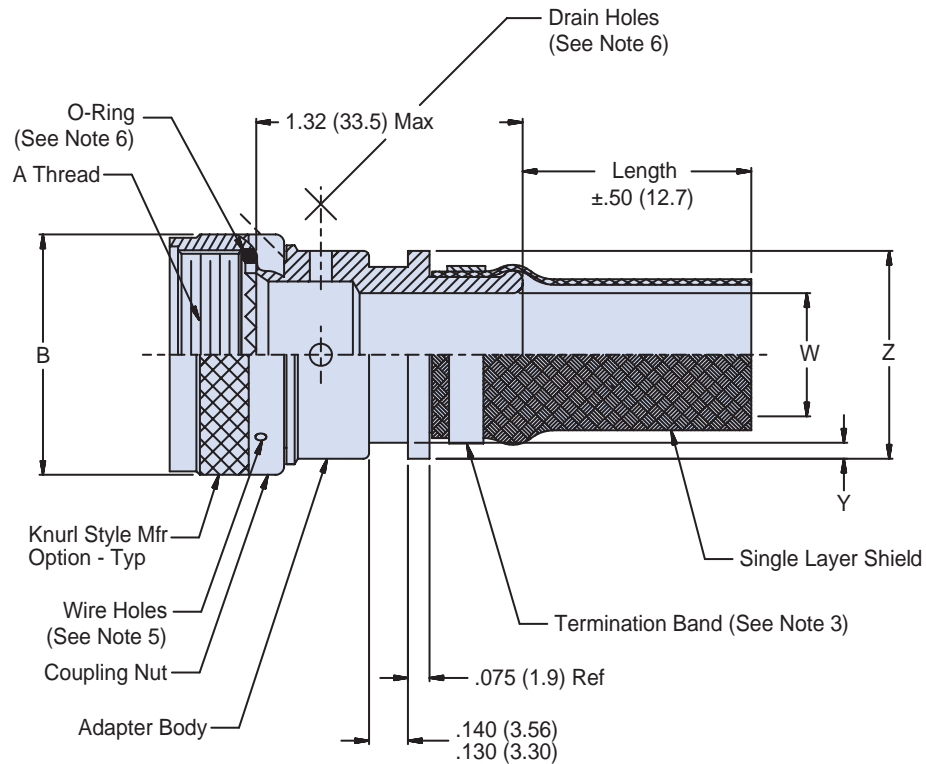

Dimensions in inches (millimeters) and are subject to change without notice.

AS85049/115

Straight RFI/EMI Shield-Sock Shrink Boot Adapter with Optional Self-Locking Coupling Nut



AS85049

B

TABLE I: Shell Size and Dimensions			
Shell Size	A Thread Class 2B	B Max Diameter	Allowable Cable Entry Size
09	M12 X 1 - 6H	.858 (21.79)	01
11	M15 X 1 - 6H	.984 (24.99)	01-03
13	M18 X 1 - 6H	1.157 (29.39)	01-05
15	M22 X 1 - 6H	1.279 (32.49)	03-07
17	M25 X 1 - 6H	1.406 (35.71)	05-09
19	M28 X 1 - 6H	1.516 (38.51)	06-10
21	M31 X 1 - 6H	1.642 (41.71)	08-12
23	M34 X 1 - 6H	1.768 (44.91)	09-13
25	M37 X 1 - 6H	1.889 (47.98)	10-14

TABLE II: Entry Size and Dimensions			
Entry Size	W ± .020 (.51)	Y +.008 (.20) -.000 (.00)	Z Max
01	.250 (6.4)	.044 (1.12)	.560 (14.2)
02	.312 (7.9)	.044 (1.12)	.630 (16.0)
03	.375 (9.5)	.044 (1.12)	.690 (17.5)
04	.438 (11.1)	.044 (1.12)	.750 (19.1)
05	.500 (12.7)	.044 (1.12)	.820 (20.8)
06	.562 (14.3)	.044 (1.12)	.890 (22.6)
07	.625 (15.9)	.044 (1.12)	.950 (24.1)
08	.688 (17.5)	.044 (1.12)	1.020 (25.9)
09	.750 (19.1)	.069 (1.75)	1.120 (28.4)
10	.812 (20.6)	.069 (1.75)	1.200 (30.5)
11	.875 (22.2)	.069 (1.75)	1.270 (32.3)
12	.938 (23.8)	.069 (1.75)	1.260 (32.0)
13	1.000 (25.4)	.069 (1.75)	1.370 (34.8)
14	1.125 (28.6)	.069 (1.75)	1.470 (37.3)

Table III: Symbol and Finish	
Symbol	Finish
N	Electroless Nickel
W	Cadmium/Olive Drab over Electroless Nickel (1000 Hour Salt Spray)
X	Nickel Fluorocarbon Polymer
Z	Zinc Nickel

Table IV: Symbol and Finish	
Symbol	Finish
K	Nickel Plate
T	Tin Plate

Table V: (Manufacturer's Option)	
Material	Finish
Copper	Tin Plate
Stainless Steel	Passivated

APPLICATION NOTES

- Assembly identification with manufacturer's name and part number, space permitting.
- Metric equivalents are given for general information only and are based on 1.00 inch = 25.4 mm.
- Termination band configuration is not controlled. Band with buckle may exceed the "Z" dimensions (see Table II) provided the band does not interfere with boot attachment. Band material shall be as specified in Table V.
- Termination of the accessory shield with harness shield may be performed with a GS85049/93 shield support ring or similar split ring accessory types.
- Three (3) holes equally spaced shall be provided and accommodate .020 (0.51) maximum safety wire for the non-self-locking coupling configuration.
- .125 (3.2 mm) diameter drain holes will be provided, 4 places, equally spaced (Optional, see part number development). O-Ring not required when drain hole option is specified.
- Material/Finish:
 Adapter, coupling nut - Al alloy/see Table III.
 Termination band - See Table V (manufacturer's option).
 Braid - Copper/see Table IV.
 O-Ring - Silicone/N.A.

Dimensions in inches (millimeters) and are subject to change without notice.

AS85049/117

90° RFI/EMI Shield-Sock Shrink Boot Adapter With Optional Self-Locking Coupling Nut

CONNECTOR DESIGNATOR:

H MIL-DTL-38999 Series III and IV
EN3645

Product Series and
Specification Sheet

Shield Finish
(Table IV)

Entry Size
(Table II)

Drain Hole
(Omit for None)

M85049/117

S

11

T

W

03

- 6

D

S = Detented, Self-Locking
- = Non-Self-Locking (Use Dash)
N = Non-Detented, Self-Locking

Shell Size
(Table I)

Finish
(Table III)

Braid Length
1 Inch Increments,
6" Min., 18" Max

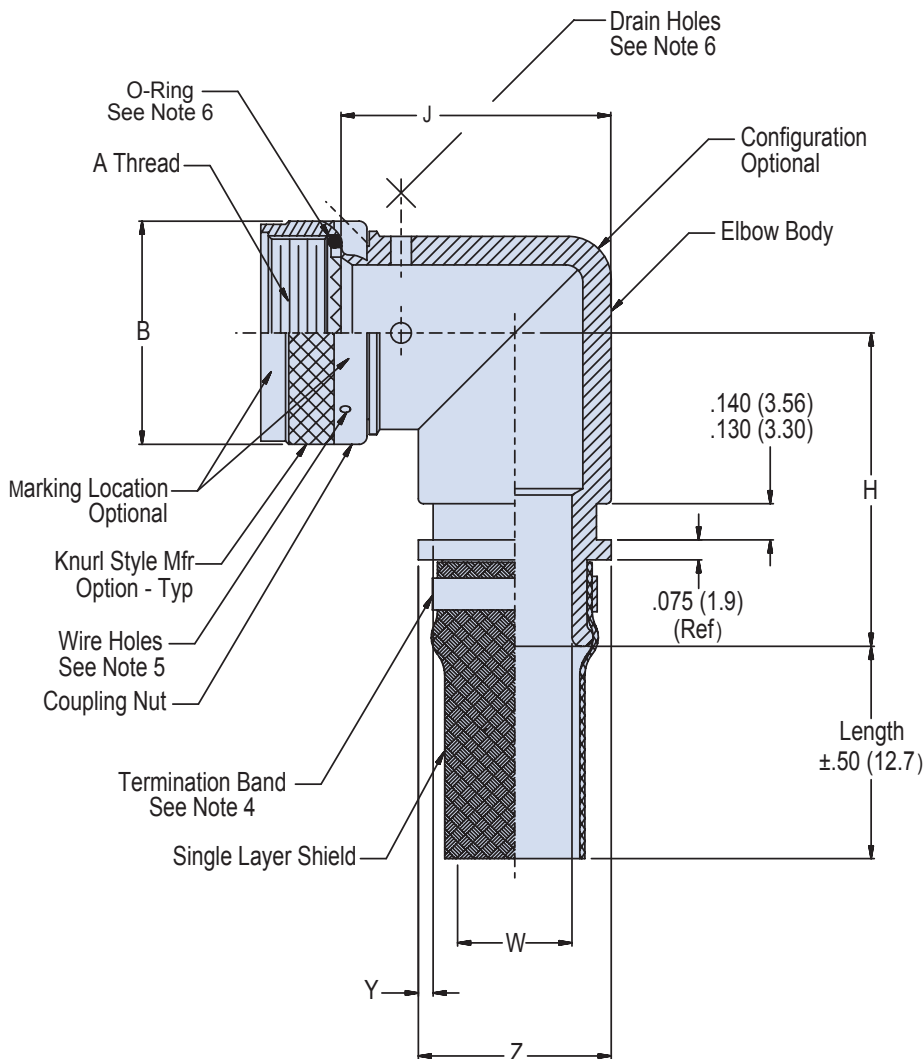

TABLE II: Entry Size and Dimensions

Entry Size	W ± .020 (.51)	Y +.008 (.20) -.000 (.00)	Z Max
01	.250 (6.4)	.044 (1.12)	.560 (14.2)
02	.312 (7.9)	.044 (1.12)	.630 (16.0)
03	.375 (9.5)	.044 (1.12)	.690 (17.5)
04	.438 (11.1)	.044 (1.12)	.750 (19.1)
05	.500 (12.7)	.044 (1.12)	.820 (20.8)
06	.562 (14.3)	.044 (1.12)	.890 (22.6)
07	.625 (15.9)	.044 (1.12)	.950 (24.1)
08	.688 (17.5)	.044 (1.12)	1.020 (25.9)
09	.750 (19.1)	.069 (1.75)	1.070 (27.2)
10	.812 (20.6)	.069 (1.75)	1.130 (28.7)
11	.875 (22.2)	.069 (1.75)	1.190 (30.2)
12	.938 (23.8)	.069 (1.75)	1.260 (32.0)
13	1.000 (25.4)	.069 (1.75)	1.320 (33.5)
14	1.125 (28.6)	.069 (1.75)	1.470 (37.3)

Dimensions in inches (millimeters) and are subject to change without notice.

AS85049/117
90° RFI/EMI Shield-Sock Shrink Boot Adapter
With Optional Self-Locking Coupling Nut



AS85049

B

TABLE I: Shell Size, Entry Size, Thread and Dimensions

Accessory Shell Size Code	A ISO Metric	B Max Diameter	H Max	J Max	Allowable Cable Entry Size
9	M12 x 1 - 6H	.858 (21.79)	1.730 (43.94)	.875 (22.23)	01
11	M15 x 1 - 6H	.984 (24.99)	1.850 (46.99)	1.000 (25.40)	01-03
13	M18 x 1 - 6H	1.157 (29.39)	1.870 (47.50)	1.125 (28.58)	01-05
15	M22 x 1 - 6H	1.279 (32.49)	1.940 (49.28)	1.312 (33.32)	03-07
17	M25 x 1 - 6H	1.406 (35.71)	2.030 (51.56)	1.500 (38.10)	05-09
19	M28 x 1 - 6H	1.516 (38.51)	2.200 (55.88)	1.750 (44.45)	06-10
21	M31 x 1 - 6H	1.642 (41.71)	2.200 (55.88)	1.750 (44.45)	08-12
23	M34 x 1 - 6H	1.768 (44.91)	2.310 (58.67)	2.000 (50.80)	09-13
25	M37 x 1 - 6H	1.889 (47.98)	2.310 (58.67)	2.000 (50.80)	10-14

Table III: Symbol and Finish

Symbol	Finish
N	Electroless Nickel
W	Cad/O.D. over electroless nickel (1000 hour salt spray)
Z	Black zinc nickel (1000 hour salt spray)

Table IV: Symbol and Finish

Symbol	Finish
K	Nickel Plate
T	Tin Plate

Table V: (Manufacturer's Option)

Material	Finish
Copper	Tin Plate
Stainless Steel	Passivated

APPLICATION NOTES

- Assembly identified with manufacturer's name and part number, space permitting.
- With Optional Self-Locking Coupling Nut Metric equivalents are given for general information only and are based on 1.000 inch (25.40 mm).
- Termination band configuration is not controlled. Band with buckle may exceed the "Z" dimension (See Table II) provided the band does not interfere with boot attachment, band material shall be specified as in Table V.
- Termination of the accessory shield with harness shield may be performed with a AS85049/93 shield support ring or similar split ring accessory types.
- Three (3) holes equally spaced shall be provided and accommodate .020 (.51) maximum safety wire for the non-self-locking coupling configuration.
- Drain holes will be provided with a .125 (3.2 mm) diameter, 4 places equally spaces (optional, see part number development). O-Ring not required when drain hole option is specified.
- Material/Finish:
 Adapter, coupling nut - Al alloy/See Table III
 Band - See Table V, manufacturer's option
 Braid - Copper/See Table IV

Dimensions in inches (millimeters) and are subject to change without notice.

© 2013 Glenair, Inc.

Mil-Spec Backshells

U.S. CAGE Code 06324

Printed in U.S.A.

CONNECTOR DESIGNATOR:
A

 AS5015 Series AS34001 Crimp,
 MIL-DTL-26482 Series II,
 SAE-AS1703 Crimp Series III,
 MIL-DTL-83723 Series I & III

Material and Finish Designator

A = Aluminum, Black Anodize
N = Aluminum, Electroless Nickel
S = Stainless Steel, Passivate
W = Aluminum, Cadmium, Olive Drab
X = Aluminum, Nickel Fluorocarbon Polymer
Y = Aluminum, Pure Dense Electrodeposited Aluminum
Z = Aluminum, Zinc-Nickel

B
**Product Series and
Basic Part Number**
M85049/118
S
08
W
Dash No.
Table I

S = Detented Self-Locking
N = Non-Detented Self-Locking
 Use Dash (-) for Non-Self-Locking
 (See Note 5)

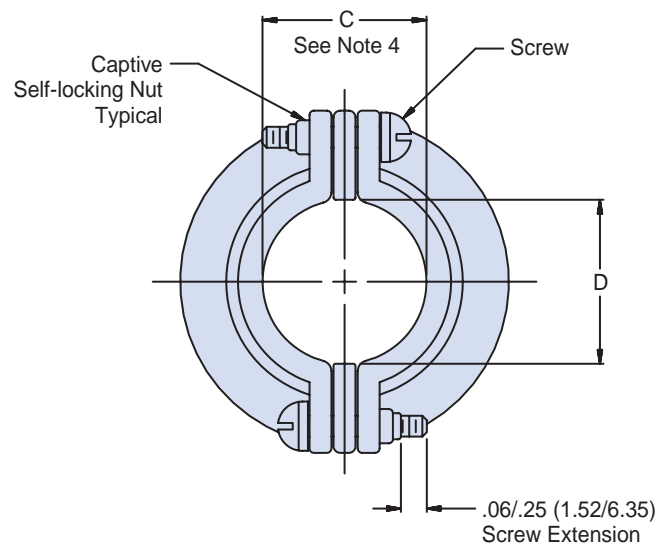
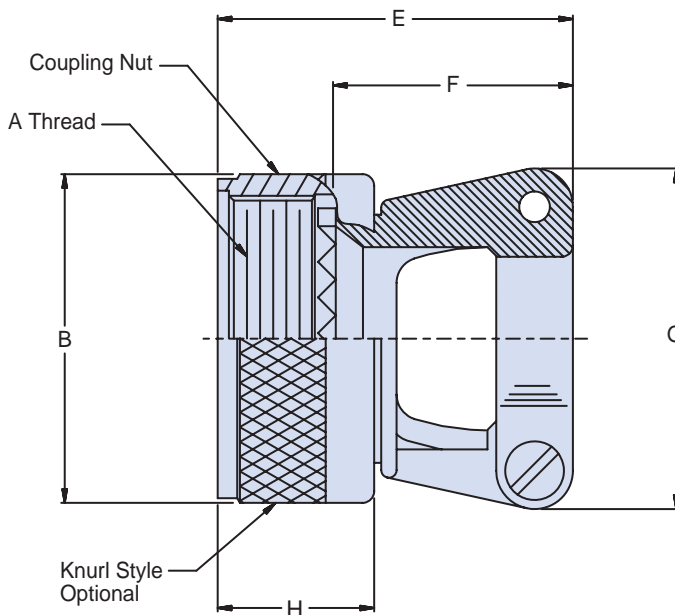
APPLICATION NOTES

1. Assembly to be identified with manufacturer's name and part number, space permitting.
2. Glenair Series 600 Backshell Assembly Tools are recommended for assembly and installation.
3. Metric equivalents in parentheses (mm) are given for general information only and are based on 1.000 inch = 25.4 mm.
4. Cable entry is measured with saddle bars closed and bottomed on clamp ears.
5. Detented self-locking has a positive audible detented coupling.
6. Material/Finish:
 Clamp body, coupling nut, saddles - Al alloy or 300 Series SST/See Table II.
 Clamp screws and lock nuts - CRES/Passivated, Silver plate optional.
 Anti-rotation device - Corrosion resistant material

Dimensions in inches (millimeters) and are subject to change without notice.

AS85049/118
Straight Strain Relief
Self-Locking or Non-Self-Locking



AS85049

B

TABLE I: Dash Number, Shell Size, Thread and Dimensions (Continued Below)

Dash No.	Screw Size	MIL-DTL-83723 Series III	MIL-DTL-5015 MS3400 Series	AS81703 Series III	MIL-DTL-26482 Series II	A Thread Class 2B	B Dia Max	C Dim ± .031 (0.8)	D Min	E Max Length
03	4-40	--	--	3	--	9/16-24 UNEF	.95 (24.1)	.219 (5.6)	.22 (5.6)	1.14 (29.0)
08	4-40	8	8S	--	8	1/2-20 UNF	.89 (22.6)	.219 (5.6)	.22 (5.6)	1.14 (29.0)
10	4-40	10	10S, 10SL	--	10	5/8-20 UNEF	1.01 (25.7)	.264 (6.7)	.27 (6.9)	1.25 (31.8)
12	4-40	12	12, 12S	7	12	3/4-20 UNEF	1.14 (29.0)	.344 (8.7)	.35 (8.9)	1.38 (35.1)
14	4-40	14	14, 14S	12	14	7/8-20 UNEF	1.26 (32.0)	.460 (11.7)	.47 (11.9)	1.38 (35.1)
16	4-40	16	16, 16S	19	16	1-20 UNEF	1.39 (35.3)	.545 (13.8)	.55 (14.0)	1.50 (38.1)
18	6-32	18	18	27	18	1 1/16-18 UNEF	1.51 (38.4)	.615 (15.6)	.62 (15.7)	1.75 (44.5)
20	6-32	20	20	37	20	1 3/16-18 UNEF	1.64 (41.7)	.698 (17.7)	.70 (17.8)	1.88 (47.8)
22	6-32	22	22	--	24	1 5/16-18 UNEF	1.176 (44.7)	.780 (19.8)	.78 (19.8)	2.00 (50.8)
24	8-32	24	24	--	--	1 7/16-18 UNEF	1.89 (48.0)	.850 (21.6)	.85 (21.6)	2.13 (54.1)
28	8-32	--	28	--	--	1 3/4-18 UNS	2.14 (54.4)	.950 (24.1)	.95 (24.1)	2.56 (65.0)
32	8-32	--	32	--	--	2-18 UNS	2.40 (61.0)	1.015 (25.8)	1.02 (25.2)	2.81 (71.4)
36	8-32	--	36	--	--	2 1/4-16 UN	2.64 (67.1)	1.187 (30.1)	1.19 (30.2)	3.06 (77.7)
40	8-32	--	40	--	--	2 1/2-16 UN	2.89 (73.4)	1.220 (31.0)	1.22 (31.0)	3.16 (80.3)
44	8-32	--	44	--	--	2 3/4-16 UN	3.14 (79.8)	1.500 (38.1)	1.50 (38.1)	3.53 (89.7)
48	8-32	--	48	--	--	3-16 UN	3.39 (86.1)	1.625 (41.3)	1.63 (41.4)	3.93 (99.8)
61	8-32	--	--	61	--	1 1/2-18 UNEF	1.95 (49.5)	.850 (21.6)	.85 (21.6)	2.13 (54.1)

TABLE I: (Continued from Above)

Dash No.	Screw Size	MIL-DTL-83723 Series III	MIL-DTL-5015 MS3400 Series	AS81703 Series III	MIL-DTL-26482 Series II	F Dim	G Dim Max	H Dim Max
03	4-40	--	--	3	--	.77 (19.6) .51 (13.0)	.88 (22.4)	.710 (18.00)
08	4-40	8	8S	--	8	.77 (19.6) .51 (13.0)	.88 (22.4)	.710 (18.00)
10	4-40	10	10S, 10SL	--	10	.89 (22.6) .64 (16.3)	.94 (23.9)	.710 (18.00)
12	4-40	12	12, 12S	7	12	1.01 (25.7) .76 (19.3)	1.12 (28.4)	.710 (18.00)
14	4-40	14	14, 14S	12	14	1.01 (25.7) .76 (19.3)	1.19 (30.3)	.710 (18.00)
16	4-40	16	16, 16S	19	16	1.13 (28.7) .88 (22.4)	1.44 (36.6)	.710 (18.00)
18	6-32	18	18	27	18	1.38 (35.1) 1.13 (28.7)	1.56 (39.6)	.710 (18.00)
20	6-32	20	20	37	20	1.51 (38.4) 1.25 (31.8)	1.69 (42.9)	.710 (18.00)
22	6-32	22	22	--	24	1.62 (41.1) 1.38 (35.1)	1.75 (44.5)	.710 (18.00)
24	8-32	24	24	--	--	1.76 (44.7) 1.51 (38.4)	1.88 (47.8)	.710 (18.00)
28	8-32	--	28	--	--	2.03 (51.6) 1.67 (42.5)	2.12 (53.8)	.890 (22.6)
32	8-32	--	32	--	--	2.28 (57.9) 1.87 (47.5)	2.50 (63.5)	.890 (22.6)
36	8-32	--	36	--	--	2.53 (64.3) 2.22 (56.4)	2.62 (66.5)	.890 (22.6)
40	8-32	--	40	--	--	2.63 (66.8) 2.41 (61.2)	2.68 (68.1)	.890 (22.6)
44	8-32	--	44	--	--	3.00 (76.2) 2.80 (71.1)	3.00 (76.2)	.890 (22.6)
48	8-32	--	48	--	--	3.40 (86.4) 3.20 (81.3)	3.50 (88.9)	.890 (22.6)
61	8-32	--	--	61	--	1.76 (44.7) 1.51 (38.5)	1.88 (47.8)	.710 (18.00)

Dimensions in inches (millimeters) and are subject to change without notice.

CONNECTOR DESIGNATOR:
A

 AS5015 Series AS34001 Crimp,
 MIL-DTL-26482 Series II,
 SAE-AS1703 Crimp Series III,
 MIL-DTL-83723 Series I & III

**Product Series and
Basic Part Number**
M85049/120
Dash No.

 Table I
 Page 62-26

S
08
Finish

 Table II
 Page 62-26

W

S = Detented Self-Locking
N = Non-Detented Self-Locking
 Use Dash (-) for Non-Self-Locking
 (See Note 5)

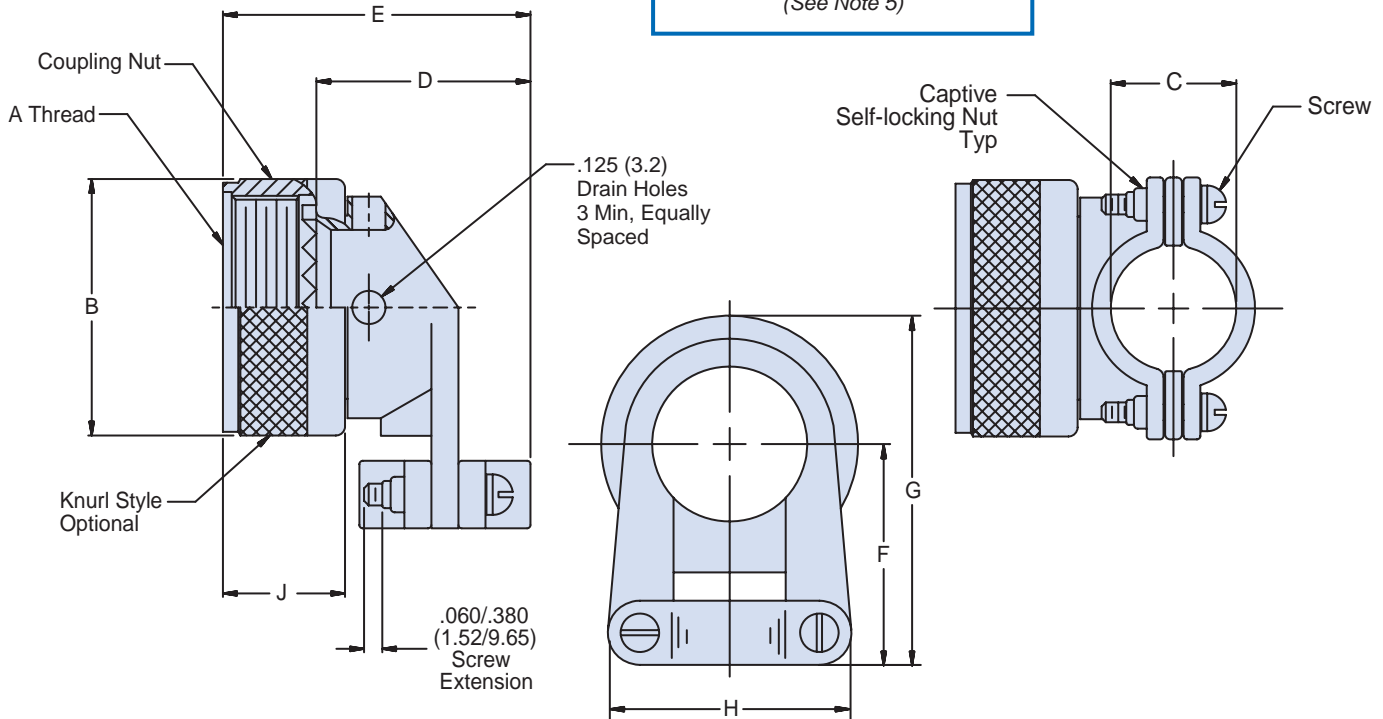
APPLICATION NOTES

1. Assembly to be identified with manufacturer's name and part number, space permitting.
2. Glenair Series 600 Backshell Assembly Tools are recommended for assembly and installation.
3. Metric equivalents in parentheses (mm) are given for general information only and are based on 1.000 inch = 25.4 mm.
4. Cable entry is measured with saddle bars closed and bottomed on clamp ears.
5. Detented self-locking has a positive audible detented coupling.
6. Material/Finish:
 Clamp body, coupling nut, saddles - Al alloy or 300 Series SST/See Table II.
 Clamp screws and lock nuts - CRES/Passivated, Silver plate optional.
 Anti-rotation device - Corrosion resistant material

Dimensions in inches (millimeters) and are subject to change without notice.

AS85049/120
90° Strain Relief
Self-Locking or Non-Self-Locking



AS85049

B

TABLE I: Dash Number, Shell Size, Thread and Dimensions (Continued Below)

Dash No.	Screw Size	MIL-DTL-83723 Series III	MIL-DTL-5015 MS3400 Series	AS81703 Series III	MIL-DTL-26482 Series II	A Thread Class 2B	B Dia Max	C Dim ± .031 (0.8)	D Max	E Max Length
03	4-40	--	--	3	--	9/16-24 UNEF	.95 (24.1)	.219 (5.6)	.93 (23.6)	1.29 (32.8)
08	4-40	8	8S	--	8	1/2-20 UNF	.89 (22.6)	.219 (5.6)	.93 (23.6)	1.29 (32.8)
10	4-40	10	10S, 10SL	--	10	5/8-20 UNEF	1.01 (25.7)	.264 (6.7)	1.02 (25.9)	1.38 (35.1)
12	4-40	12	12, 12S	7	12	3/4-20 UNEF	1.14 (29.0)	.344 (8.7)	1.21 (30.7)	1.57 (39.9)
14	4-40	14	14, 14S	12	14	7/8-20 UNEF	1.26 (32.0)	.460 (11.7)	1.27 (32.3)	1.63 (41.4)
16	4-40	16	16, 16S	19	16	1-20 UNEF	1.39 (35.3)	.545 (13.8)	1.42 (36.1)	1.78 (45.2)
18	6-32	18	18	27	18	1 1/16-18 UNEF	1.51 (38.4)	.615 (15.6)	1.53 (38.9)	1.89 (48.0)
20	6-32	20	20	37	20	1 3/16-18 UNEF	1.64 (41.7)	.698 (17.7)	1.65 (41.9)	2.01 (51.1)
22	6-32	22	22	--	24	1 5/16-18 UNEF	1.176 (44.7)	.780 (19.8)	1.78 (45.2)	2.14 (54.4)
24	8-32	24	24	--	--	1 7/16-18 UNEF	1.89 (48.0)	.850 (21.6)	1.90 (48.3)	2.26 (57.4)
28	8-32	--	28	--	--	1 3/4-18 UNS	2.14 (54.4)	.950 (24.1)	2.20 (55.9)	2.72 (69.1)
32	8-32	--	32	--	--	2-18 UNS	2.40 (61.0)	1.015 (25.8)	2.27 (57.7)	2.79 (70.9)
36	8-32	--	36	--	--	2 1/4-16 UN	2.64 (67.1)	1.187 (30.1)	2.39 (60.7)	3.91 (73.9)
40	8-32	--	40	--	--	2 1/2-16 UN	2.89 (73.4)	1.220 (31.0)	2.52 (64.0)	3.04 (77.2)
44	8-32	--	44	--	--	2 3/4-16 UN	3.14 (79.8)	1.500 (38.1)	2.77 (70.4)	3.29 (83.6)
48	8-32	--	48	--	--	3-16 UN	3.39 (86.1)	1.625 (41.3)	2.89 (73.4)	3.41 (86.6)
61	8-32	--	--	61	--	1 1/2-18 UNEF	1.95 (49.5)	.850 (21.6)	1.90 (48.3)	2.26 (57.4)

TABLE I: (Continued from Above)

Dash No.	Screw Size	MIL-DTL-83723 Series III	MIL-DTL-5015 MS3400 Series	AS81703 Series III	MIL-DTL-26482 Series II	F Dim Max	G Dim Max	H Dim Max	J Dim Max
03	4-40	--	--	3	--	.84 (21.3)	1.32 (33.5)	.88 (22.4)	.710 (18.0)
08	4-40	8	8S	--	8	.81 (20.6)	1.26 (32.0)	.88 (22.4)	.710 (18.0)
10	4-40	10	10S, 10SL	--	10	.87 (22.1)	1.38 (35.1)	.94 (23.9)	.710 (18.0)
12	4-40	12	12, 12S	7	12	.93 (23.6)	1.50 (38.1)	1.12 (28.4)	.710 (18.0)
14	4-40	14	14, 14S	12	14	1.00 (25.4)	1.62 (41.4)	1.19 (30.2)	.710 (18.0)
16	4-40	16	16, 16S	19	16	1.06 (26.9)	1.75 (44.5)	1.44 (36.6)	.710 (18.0)
18	6-32	18	18	27	18	1.23 (31.2)	1.99 (50.5)	1.56 (39.6)	.710 (18.0)
20	6-32	20	20	37	20	1.30 (33.0)	2.07 (52.6)	1.69 (42.9)	.710 (18.0)
22	6-32	22	22	--	24	1.36 (34.5)	2.25 (57.2)	1.75 (44.5)	.710 (18.0)
24	8-32	24	24	--	--	1.42 (36.1)	2.37 (60.2)	1.88 (47.8)	.710 (18.0)
28	8-32	--	28	--	--	1.63 (41.4)	2.70 (68.6)	2.12 (53.8)	.890 (22.6)
32	8-32	--	32	--	--	1.86 (47.2)	3.05 (77.5)	2.50 (63.5)	.890 (22.6)
36	8-32	--	36	--	--	1.98 (50.3)	3.30 (83.8)	2.62 (66.5)	.890 (22.6)
40	8-32	--	40	--	--	2.10 (53.3)	3.55 (90.2)	2.68 (68.1)	.890 (22.6)
44	8-32	--	44	--	--	2.36 (59.9)	3.93 (99.8)	3.00 (76.2)	.890 (22.6)
48	8-32	--	48	--	--	2.48 (63.0)	4.18 (106.2)	3.50 (88.9)	.890 (22.6)
61	8-32	--	--	61	--	1.45 (36.8)	2.43 (61.7)	1.88 (47.8)	.710 (18.0)

TABLE II: Material and Finish

Symbol	Material	Finish
A	Aluminum Alloy	Black Anodize
N		Electroless Nickel
W		Cadmium, Olive Drab
X		Nickel Fluorocarbon Polymer
Y		Pure Dense Electrodeposited Aluminum
Z		Zinc Nickel
S	300 Series SST	Passivated

Dimensions in inches (millimeters) and are subject to change without notice.



AS85049/121

Straight Strain Relief

Self-Locking or Non-Self-Locking

CONNECTOR DESIGNATOR:
F MIL-DTL-38999 Series I and II

**Product Series and
Basic Part Number**
M85049/121
Dash No.
*Table I
Page 62-28*
S
Finish
*Table II
Page 62-28*
08
W

S = Detented Self-Locking
N = Non-Detented Self-Locking
 Use Dash (-) for Non-Self-Locking
 (See Note 5)

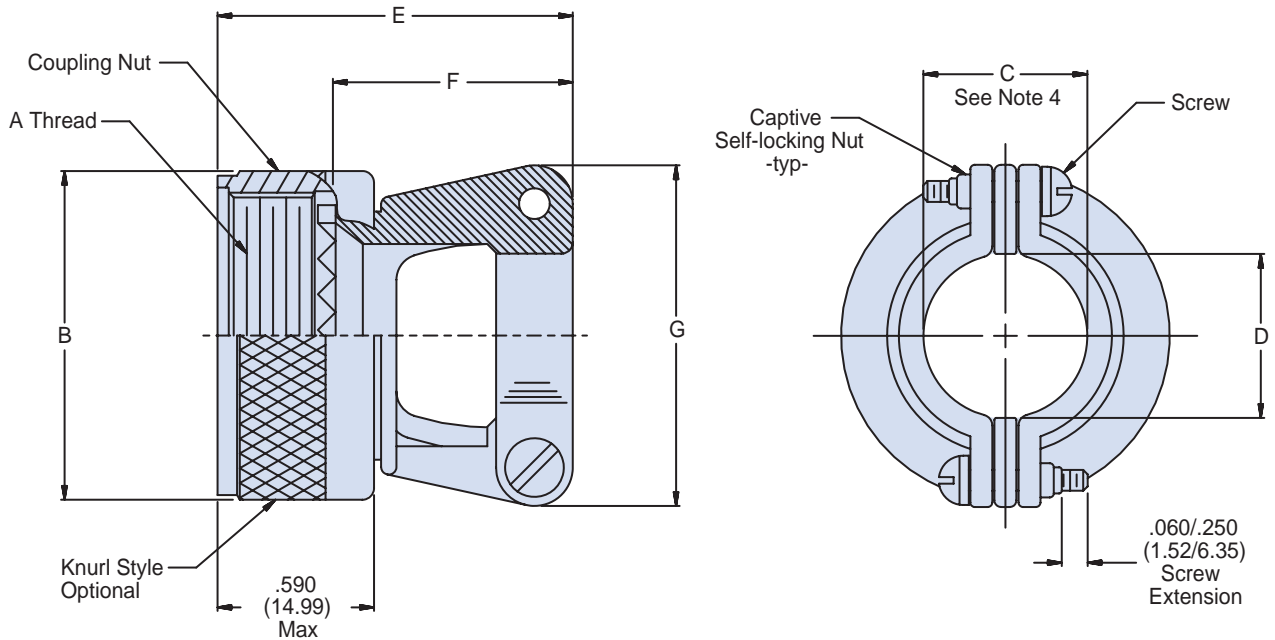
APPLICATION NOTES

1. Assembly to be identified with manufacturer's name and part number, space permitting.
2. Glenair Series 600 Backshell Assembly Tools are recommended for assembly and installation.
3. Metric equivalents in parentheses (mm) are given for general information only and are based on 1.000 inch = 25.4 mm.
4. Cable entry is measured with saddle bars closed and bottomed on clamp ears.
5. Detented self-locking has a positive audible detented coupling.
6. Material/Finish:
 Clamp body, coupling nut, saddles - Al alloy or 300 Series SST/See Table II.
 Clamp screws and lock nuts - CRES/Passivated, Silver plate optional.
 Anti-rotation device - Corrosion resistant material

Dimensions in inches (millimeters) and are subject to change without notice.

AS85049/121
Straight Strain Relief
Self-Locking or Non-Self-Locking



AS85049

B

TABLE I: Dash Number, Shell Size, Thread and Dimensions (Continued Below)

Dash No.	Screw Size	Connector Shell Size		A Thread Class 2B	B Dia Max	C Dim ± .031 (0.79) See Note 4	D Min	E Max Length	F Dim	G Max
		Series I	Series II							
08	4-40	9	8	7/16-28 UNEF	.858 (21.8)	.219 (5.6)	.22 (5.6)	1.01 (25.7)	.77 (19.6) .51 (13.0)	.88 (22.4)
10	4-40	11	10	9/16-24 UNEF	.984 (25.0)	.264 (6.7)	.27 (6.9)	1.13 (28.7)	.89 (22.6) .64 (16.3)	.94 (23.9)
12	4-40	13	12	11/16-24 UNEF	1.157 (29.4)	.344 (8.7)	.35 (8.9)	1.25 (31.8)	1.01 (25.7) .76 (19.3)	1.12 (28.4)
14	4-40	15	14	13/16-20 UNEF	1.297 (32.5)	.460 (11.7)	.47 (11.9)	1.25 (31.8)	1.01 (25.7) .76 (19.3)	1.19 (30.2)
16	4-40	17	16	15/16-20 UNEF	1.406 (35.7)	.545 (13.8)	.55 (14.0)	1.37 (34.8)	1.13 (28.7) .88 (22.4)	1.44 (36.6)
18	6-32	19	18	1 1/16-18 UNEF	1.516 (38.5)	.615 (15.6)	.62 (15.7)	1.62 (41.1)	1.38 (35.1) 1.13 (28.7)	1.56 (39.6)
20	6-32	21	20	1 3/16-18 UNEF	1.642 (41.7)	.698 (17.7)	.70 (17.8)	1.75 (44.5)	1.51 (38.4) 1.26 (32.0)	1.69 (42.9)
22	6-32	23	22	1 5/16-18 UNEF	1.768 (44.9)	.780 (19.8)	.78 (19.8)	1.87 (47.5)	1.63 (41.4) 1.38 (35.1)	1.75 (44.5)
24	8-32	25	24	1 7/16-18 UNEF	1.869 (47.5)	.850 (21.6)	.85 (21.6)	2.00 (50.8)	1.76 (44.7) 1.51 (38.4)	1.88 (47.8)

TABLE II: Material and Finish

Symbol	Material	Finish
A	Aluminum Alloy	Black Anodize
N		Electroless Nickel
W		Cadmium, Olive Drab
X		Nickel Fluorocarbon Polymer
Y		Pure Dense Electrodeposited Aluminum
Z		Zinc Nickel
S	300 Series SST	Passivated

Dimensions in inches (millimeters) and are subject to change without notice.

AS85049/123

90° Strain Relief

Self-Locking or Non-Self Locking

CONNECTOR DESIGNATOR:

F MIL-DTL-38999 Series I and II

**Product Series and
Basic Part Number**
M85049/123
Dash No.
Table I
Page 62-30

S
Finish
Table II
Page 62-30

08
W

S = Detented Self-Locking
N = Non-Detented Self-Locking
 Use Dash (-) for Non-Self-Locking
 (See Note 5)

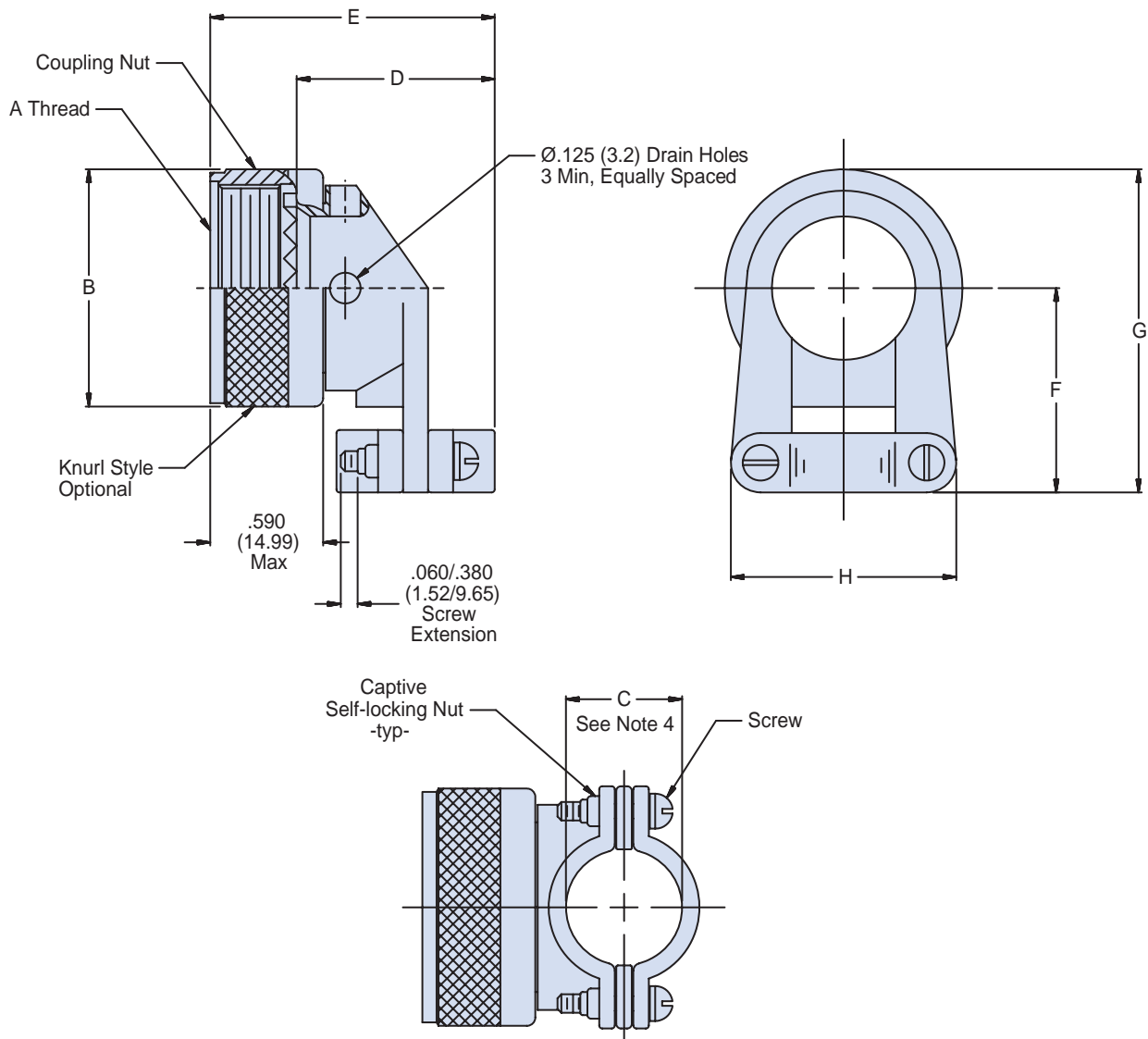

Dimensions in inches (millimeters) and are subject to change without notice.

AS85049/123
90° Strain Relief
Self-Locking or Non-Self Locking



AS85049

TABLE I: Dash Number, Shell Size, Thread and Dimensions (Continued Below)

Dash No.	Screw Size	Connector Shell Size		A Thread Class 2B	B Dia Max	C Dim ± .031 (0.79) See Note 4	D Max	E Max Length	F Max	G Max	H Max
		Series I	Series II								
08	4-40	9	8	7/16-28 UNEF	.858 (21.8)	.219 (5.6)	.86 (21.8)	1.10 (27.9)	.81 (20.6)	1.24 (31.5)	.88 (22.4)
10	4-40	11	10	9/16-24 UNEF	.984 (25.0)	.264 (6.7)	.94 (23.9)	1.18 (30.0)	.87 (22.1)	1.36 (34.5)	.94 (23.9)
12	4-40	13	12	11/16-24 UNEF	1.157 (29.4)	.344 (8.7)	1.14 (29.0)	1.38 (35.1)	.93 (23.6)	1.51 (38.4)	1.12 (28.4)
14	4-40	15	14	13/16-20 UNEF	1.297 (32.5)	.460 (11.7)	1.20 (30.5)	1.44 (36.6)	.99 (25.1)	1.63 (41.4)	1.19 (30.2)
16	4-40	17	16	15/16-20 UNEF	1.406 (35.7)	.545 (13.8)	1.34 (34.0)	1.58 (40.1)	1.09 (27.7)	1.76 (44.7)	1.44 (36.6)
18	6-32	19	18	1 1/16-18 UNEF	1.516 (38.5)	.615 (15.6)	1.46 (37.1)	1.70 (43.2)	1.23 (31.2)	1.99 (50.5)	1.56 (39.6)
20	6-32	21	20	1 3/16-18 UNEF	1.642 (41.7)	.698 (17.7)	1.58 (40.1)	1.82 (46.2)	1.30 (33.0)	2.12 (53.8)	1.69 (42.9)
22	6-32	23	22	1 5/16-18 UNEF	1.768 (44.9)	.780 (19.8)	1.71 (43.4)	1.95 (49.5)	1.36 (34.5)	2.24 (56.9)	1.75 (44.5)
24	8-32	25	24	1 7/16-18 UNEF	1.869 (47.5)	.850 (21.6)	1.83 (46.5)	2.07 (52.6)	1.42 (36.1)	2.35 (59.7)	1.88 (47.8)

B

TABLE II: Material and Finish

Symbol	Material	Finish
A	Aluminum Alloy	Black Anodize
N		Electroless Nickel
W		Cadmium, Olive Drab
X		Nickel Fluorocarbon Polymer
Y		Pure Dense Electrodeposited Aluminum
Z		Zinc Nickel
S	300 Series SST	Passivated

APPLICATION NOTES

1. Assembly to be identified with manufacturer's name and part number, space permitting.
2. Glenair Series 600 Backshell Assembly Tools are recommended for assembly and installation.
3. Metric equivalents in parentheses (mm) are given for general information only and are based on 1.000 inch = 25.4 mm.
4. Cable entry is measured with saddle bars closed and bottomed on clamp ears.
5. Detented self-locking has a positive audible detented coupling.
6. Material/Finish:
 Clamp body, coupling nut, saddles - Al alloy or 300 Series SST/See Table II.
 Clamp screws and lock nuts - CRES/Passivated, Silver plate optional.
 Anti-rotation device - Corrosion resistant material

Dimensions in inches (millimeters) and are subject to change without notice.

AS85049/124

Straight Strain Relief

Self-Locking or Non-Self-Locking

CONNECTOR DESIGNATOR:
H MIL-DTL-38999 Series III & IV
EN3645

**Product Series and
Basic Part Number**
M85049/124
Dash No.
Table I
Page 62-32

S
Finish
Table II
Page 62-32

09
W

S = Detented Self-Locking
N = Non-Detented Self-Locking
Use Dash (-) for Non-Self-Locking
(See Note 5)

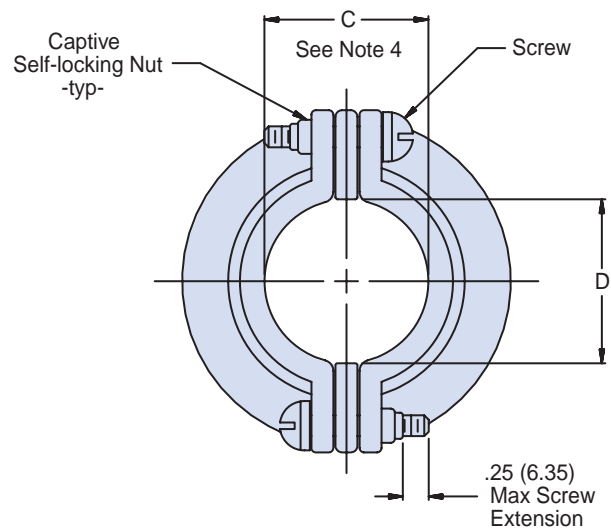
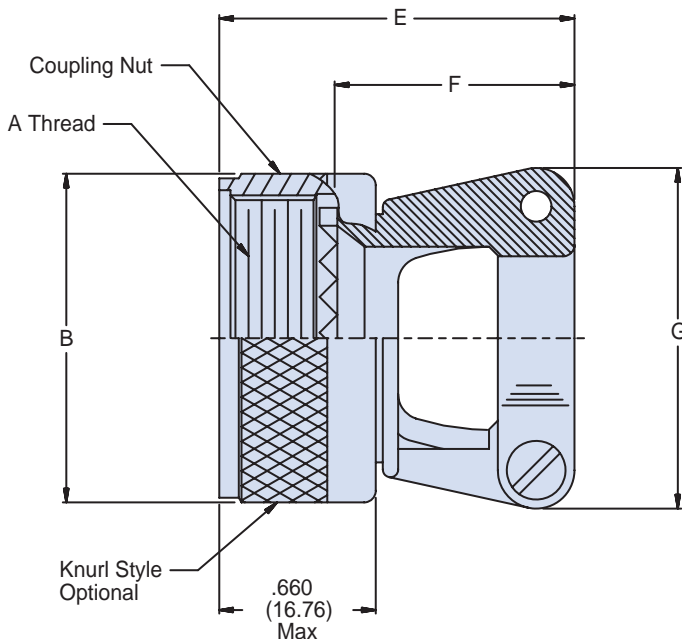

Dimensions in inches (millimeters) and are subject to change without notice.

AS85049/124
Straight Strain Relief
Self-Locking or Non-Self-Locking



AS85049

B

TABLE I: Dash Number, Shell Size, Thread and Dimensions (Continued Below)

Dash No.	Screw Size	Shell Size Code (Ref)	A Thread ISO Metric	B Dia Max	C Dim ± .031 (0.79) See Note 4	D Min	E Max Length	F Max	G Max
09	4-40	A	M12 x 1 - 6H	.858 (21.8)	.219 (5.6)	.22 (5.6)	1.05 (26.7)	.77 (19.6)	.88 (22.4)
11	4-40	B	M15 x 1 - 6H	.984 (25.0)	.264 (6.7)	.27 (6.9)	1.17 (22.6)	.89 (22.6)	.94 (23.9)
13	4-40	C	M18 x 1 - 6H	1.157 (29.4)	.344 (8.7)	.35 (8.9)	1.29 (32.8)	1.01 (25.7)	1.12 (28.4)
15	4-40	D	M22 x 1 - 6H	1.297 (32.5)	.460 (11.7)	.47 (11.9)	1.29 (32.8)	1.01 (25.7)	1.19 (30.2)
17	4-40	E	M25 x 1 - 6H	1.406 (35.7)	.545 (13.8)	.55 (14.0)	1.41 (35.8)	1.13 (28.7)	1.44 (36.6)
19	6-32	F	M28 x 1 - 6H	1.516 (38.5)	.615 (15.6)	.62 (15.7)	1.66 (42.2)	1.38 (35.1)	1.56 (39.6)
21	6-32	G	M31 x 1 - 6H	1.642 (41.7)	.698 (17.7)	.70 (17.8)	1.79 (45.5)	1.51 (38.4)	1.69 (42.9)
23	6-32	H	M34 x 1 - 6H	1.768 (44.9)	.780 (19.8)	.78 (19.8)	1.91 (48.5)	1.63 (41.4)	1.75 (44.5)
25	8-32	J	M37 x 1 - 6H	1.869 (47.5)	.850 (21.6)	.85 (21.6)	2.04 (51.8)	1.76 (44.7)	1.88 (47.8)

TABLE II: Material and Finish

Symbol	Material	Finish
A	Aluminum Alloy	Black Anodize
N		Electroless Nickel
W		Cadmium, Olive Drab
X		Nickel Fluorocarbon Polymer
Y		Pure Dense Electrodeposited Aluminum
Z		Zinc Nickel
S	300 Series SST	Passivated

APPLICATION NOTES

1. Assembly to be identified with manufacturer's name and part number, space permitting.
2. Glenair Series 600 Backshell Assembly Tools are recommended for assembly and installation.
3. Metric equivalents in parentheses (mm) are given for general information only and are based on 1.000 inch = 25.4 mm.
4. Cable entry is measured with saddle bars closed and bottomed on clamp ears.
5. Detented self-locking has a positive audible detented coupling.
6. Material/Finish:
 Clamp body, coupling nut, saddles - Al alloy or 300 Series SST/See Table II.
 Clamp screws and lock nuts - CRES/Passivated, Silver plate optional.
 Anti-rotation device - Corrosion resistant material

Dimensions in inches (millimeters) and are subject to change without notice.

CONNECTOR DESIGNATOR:

H MIL-DTL-38999 Series III & IV
EN3645

Product Series and
Basic Part Number

M85049/126

Dash No.
Table I
Page 62-34

S

Finish
Table II
Page 62-34

09

W

S = Detented Self-Locking
N = Non-Detented Self-Locking
Use Dash (-) for Non-Self-Locking
(See Note 5)

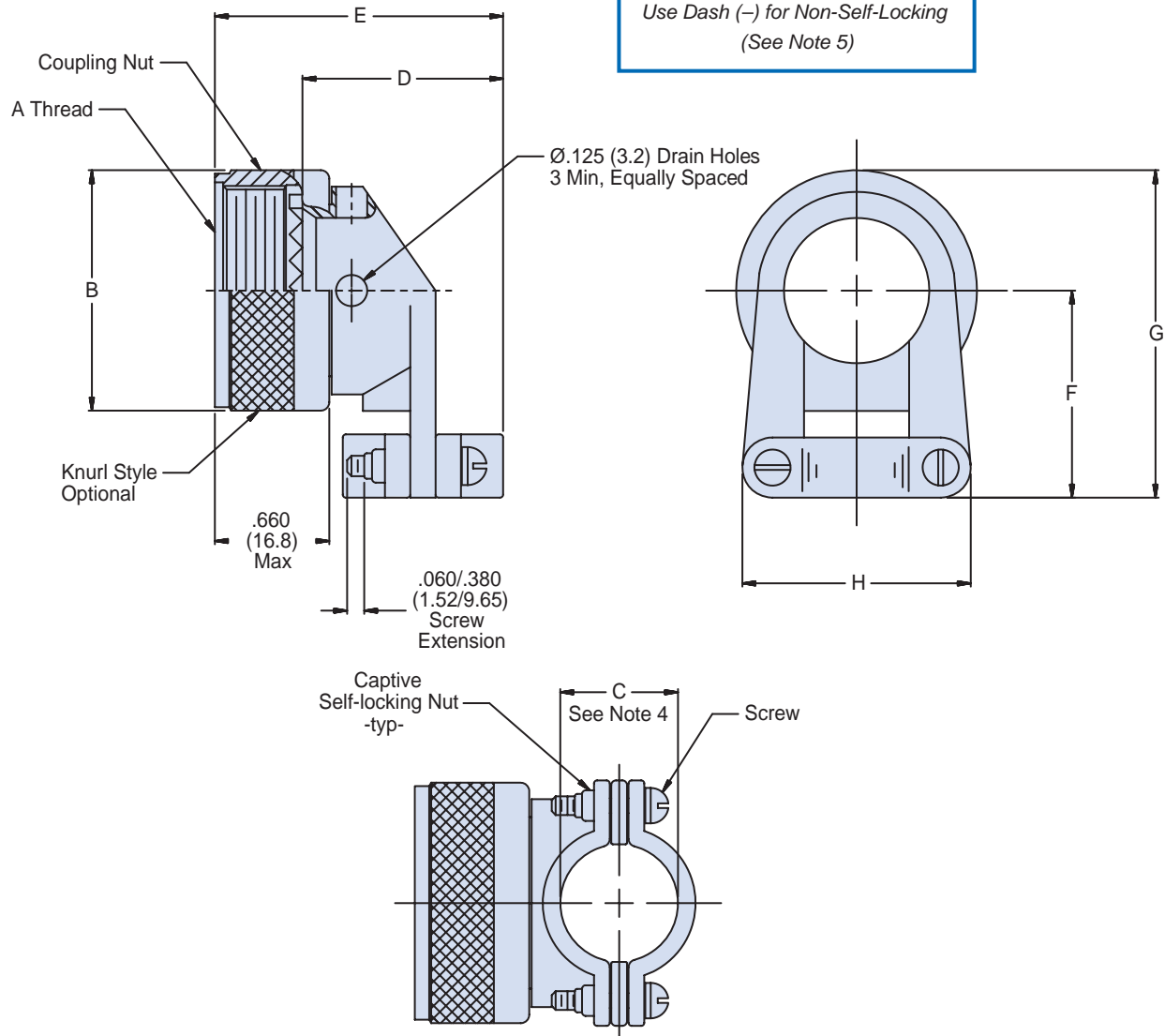

Dimensions in inches (millimeters) and are subject to change without notice.

AS85049/126
90° Strain Relief
Self-Locking or Non-Self-Locking



AS85049

TABLE I: Dash Number, Shell Size, Thread and Dimensions

Dash No.	Screw Size	Shell Size Code (Ref)	A Thread ISO Metric	B Dia Max	C Dim ± .031 (0.79) See Note 4	D Max	E Max Length	F Max	G Max	H Max
09	4-40	A	M12 x 1 - 6H	.858 (21.8)	.219 (5.6)	.86 (21.8)	1.14 (29.0)	.81 (20.6)	1.24 (31.5)	.88 (22.4)
11	4-40	B	M15 x 1 - 6H	.984 (25.0)	.264 (6.7)	.94 (23.9)	1.22 (31.0)	.87 (22.1)	1.36 (34.5)	.94 (23.9)
13	4-40	C	M18 x 1 - 6H	1.157 (29.4)	.344 (8.7)	1.14 (29.0)	1.42 (36.1)	.93 (23.6)	1.51 (38.4)	1.12 (28.4)
15	4-40	D	M22 x 1 - 6H	1.297 (32.5)	.460 (11.7)	1.20 (30.5)	1.48 (37.6)	.99 (25.1)	1.63 (41.4)	1.19 (30.2)
17	4-40	E	M25 x 1 - 6H	1.406 (35.7)	.545 (13.8)	1.34 (34.0)	1.62 (41.1)	1.09 (27.7)	1.76 (44.7)	1.44 (36.6)
19	6-32	F	M28 x 1 - 6H	1.516 (38.5)	.615 (15.6)	1.46 (37.1)	1.74 (44.2)	1.23 (31.2)	1.99 (50.5)	1.56 (39.6)
21	6-32	G	M31 x 1 - 6H	1.642 (41.7)	.698 (17.7)	1.58 (40.1)	1.86 (47.2)	1.30 (33.0)	2.12 (53.8)	1.69 (42.9)
23	6-32	H	M34 x 1 - 6H	1.768 (44.9)	.780 (19.8)	1.71 (43.4)	1.99 (50.5)	1.36 (34.5)	2.24 (56.9)	1.75 (44.5)
25	8-32	J	M37 x 1 - 6H	1.869 (47.5)	.850 (21.6)	1.83 (46.5)	2.11 (53.6)	1.42 (36.1)	2.35 (59.7)	1.88 (47.8)

B

TABLE II: Material and Finish

Symbol	Material	Finish
A	Aluminum Alloy	Black Anodize
N		Electroless Nickel
W		Cadmium, Olive Drab
X		Nickel Fluorocarbon Polymer
Y		Pure Dense Electrodeposited Aluminum
Z		Zinc Nickel
S	300 Series SST	Passivated

APPLICATION NOTES

1. Assembly to be identified with manufacturer's name and part number, space permitting.
2. Glenair Series 600 Backshell Assembly Tools are recommended for assembly and installation.
3. Metric equivalents in parentheses (mm) are given for general information only and are based on 1.000 inch = 25.4 mm.
4. Cable entry is measured with saddle bars closed and bottomed on clamp ears.
5. Detented self-locking has a positive audible detented coupling.
6. Material/Finish:
 Clamp body, coupling nut, saddles - Al alloy or 300 Series SST/See Table II.
 Clamp screws and lock nuts - CRES/Passivated, Silver plate optional.
 Anti-rotation device - Corrosion resistant material

Dimensions in inches (millimeters) and are subject to change without notice.

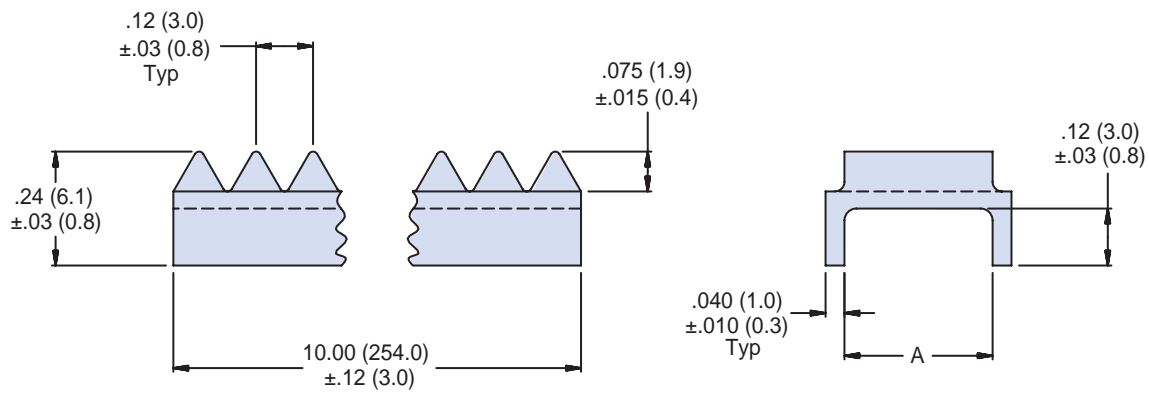
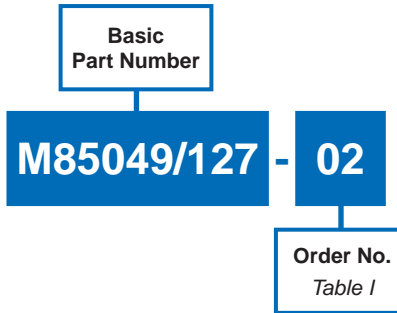
TABLE I: Order Number, Dimensions, Sizes

Order No.	A .031 (0.8) Dim	Used on Size /118, /120, /121, /123	Used on Size /124, /126
01	.312 (7.9)	03-16	09-17
02	.440 (11.2)	18-24 and 61	19-25
03	.560 (14.2)	28-40	—

APPLICATION NOTES

1. Assembly identified by bag and tag in suitable quantities.
2. Material/finish: Silicone/N.A.
3. Metric dimensions (mm) are in parentheses.

Dimensions in inches (millimeters) and are subject to change without notice.

AS85049/128-3 and AS85049/128-4
 BandMaster™ Clamping Band
 Standard Length, Flat or Precoiled



AS85049

B

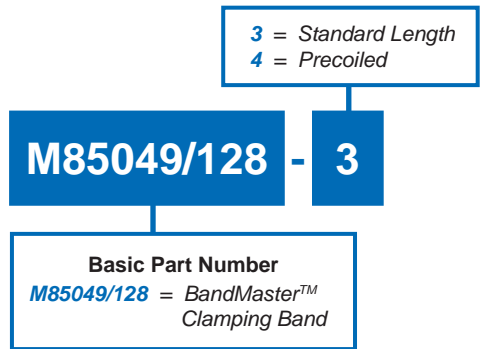

**Standard Band M85049/128-3 and
 Precoiled Standard Band M85049/128-4**

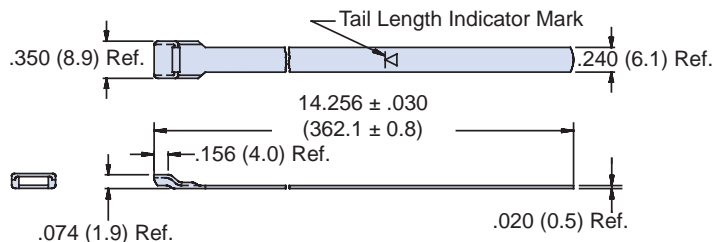

The M85049/128-3 and -4 Standard Band is precision constructed of 300 Series SST/ Passivate and designed for use with the Glenair 600-058 Hand Banding Tool, the Glenair 601-100 BandMaster Hand Banding Tool with Counter or the Glenair 600-067 Pneumatic Banding Tool. Double-wrapped bands will accommodate diameters up to approximately 1.8 inches (45.7). Bands may be ordered flat (M85049/128-3) or precoiled (M85049/128-4). Bands come bagged and tagged in quantities from 1 to 100.

Metric dimensions (mm) are indicated in parentheses. Consult factory for diameters above 2.5 inches (63.5).

Dimensions in inches (millimeters) and are subject to change without notice.

Basic
Part Number

Dash Number
Table I

M85049/130

- 18

S

Material

C = Conductive Silicone with Aluminum or Monel Mesh, Capable of 80 dB at 100 MHz. Temperature Range -57° to +260° C.

F = Fluorosilicone IAW SAE AMS-R-25988

M = Conductive Silver Filled Silicone IAW MIL-DTL-3528 Type B, Capable of 110 dB at 10GHz. Temperature Range -55° to +260° C.

N = Neoprene IAW AMS 3208.

S = Silicone IAW AA-59588

V = Viton IAW MIL-R-83248

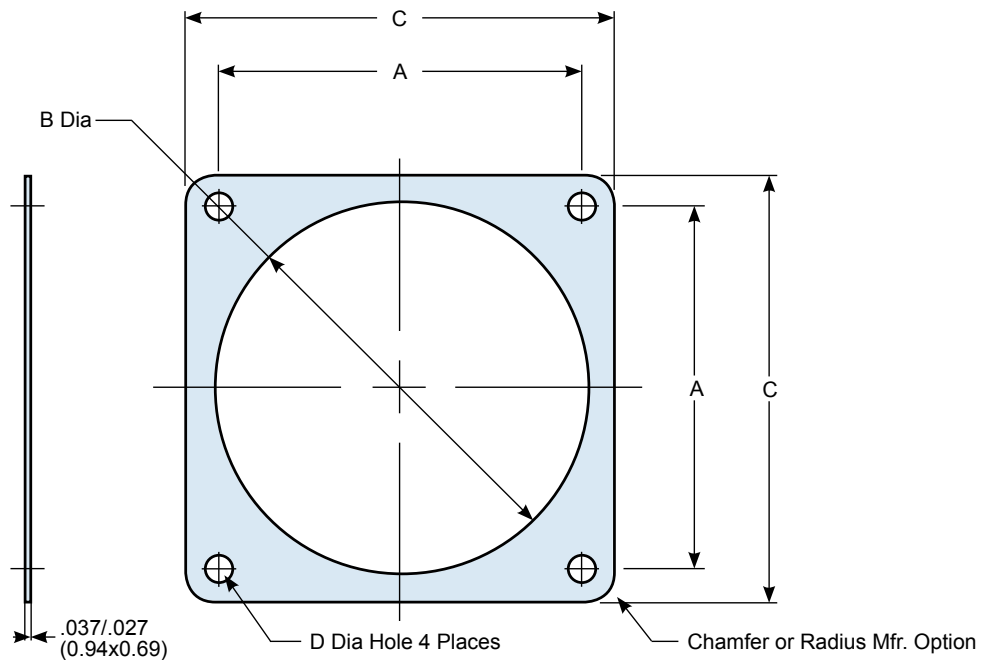

TABLE I: Dimensions

Dash No.	A ± .015 (0.38)	B +.020 (0.05) -.000	C ± .015 (0.38)	D ± .010 (0.25)
01	.594 (15.09)	.568 (14.43)	.812 (20.62)	.125 (3.18)
02	.594 (15.09)	.500 (12.70)	.875 (22.23)	.156 (3.96)
03	.625 (15.88)	.603 (15.32)	.896 (22.76)	.125 (3.18)
04	.719 (18.26)	.680 (12.27)	.937 (23.80)	.125 (3.18)
05	.719 (18.26)	.625 (15.88)	1.000 (25.40)	.156 (3.96)
06	.750 (19.05)	.750 (19.05)	1.023 (25.98)	.125 (3.18)
07	.812 (20.62)	.875 (22.23)	1.060 (26.92)	.141 (3.58)
08	.812 (20.62)	.828 (21.03)	1.114 (28.30)	.125 (3.18)
09	.813 (20.65)	.750 (19.05)	1.094 (27.79)	.141 (3.58)
10	.843 (21.41)	.875 (22.23)	1.138 (28.91)	.125 (3.58)
11	.906 (23.01)	1.005 (25.53)	1.153 (29.29)	.125 (3.58)
12	.906 (23.01)	.938 (23.83)	1.125 (28.58)	.125 (3.58)
13	.906 (23.01)	.875 (22.23)	1.188 (30.18)	.156 (3.96)
14	.969 (24.61)	1.135 (28.83)	1.258 (31.95)	.156 (3.96)
15	.969 (24.61)	1.063 (27.00)	1.250 (31.75)	.125 (3.58)

Continued on Page B-141

Dimensions in inches (millimeters) and are subject to change without notice.

**TABLE I: Dimensions
(Continued From Page B-140)**

Dash No.	A ± .015 (0.38)	B +.020 (0.05) -.000	C ± .015 (0.38)	D ± .010 (0.25)
16	.969 (24.61)	1.000 (25.4)	1.281 (32.54)	.156 (3.69)
17	1.015 (25.78)	1.125 (28.58)	1.383 (35.13)	.125 (3.18)
18	1.062 (26.97)	1.260 (32.00)	1.351 (34.32)	.156 (3.96)
19	1.062 (26.97)	1.189 (30.20)	1.343 (34.11)	.125 (3.18)
20	1.062 (26.97)	1.135 (28.83)	1.375 (34.92)	.156 (3.96)
21	1.140 (28.96)	1.312 (33.32)	1.508 (38.30)	.125 (3.18)
22	1.156 (29.36)	1.375 (34.92)	1.500 (38.10)	.141 (3.58)
23	1.156 (29.36)	1.312 (33.32)	1.467 (37.26)	.125 (3.18)
24	1.156 (29.36)	1.250 (31.75)	1.500 (38.10)	.177 (4.50)
25	1.187 (30.15)	1.266 (32.16)	1.458 (37.03)	.125 (3.58)
26	1.250 (31.75)	1.500 (38.10)	1.625 (41.28)	.141 (3.58)
27	1.250 (31.75)	1.437 (36.50)	1.562 (39.67)	.125 (3.58)
28	1.250 (31.75)	1.375 (34.92)	1.625 (41.28)	.177 (4.50)
29	1.281 (32.54)	1.500 (38.10)	1.718 (43.64)	.125 (3.18)
30	1.375 (34.92)	1.625 (41.28)	1.750 (44.45)	.177 (3.18)
31	1.375 (34.92)	1.563 (39.70)	1.703 (43.26)	.156 (3.96)
32	1.375 (34.92)	1.500 (38.10)	1.750 (44.45)	.203 (5.16)
33	1.392 (35.36)	1.625 (41.28)	1.818 (46.18)	.141 (3.58)
34	1.436 (36.47)	1.570 (39.88)	1.799 (45.69)	.125 (3.18)
35	1.500 (38.10)	1.750 (44.45)	1.875 (47.63)	.177 (3.18)
36	1.562 (39.67)	1.750 (44.45)	2.000 (50.80)	.203 (5.16)
37	1.568 (39.83)	1.875 (47.63)	2.138 (54.31)	.141 (3.58)
38	1.719 (43.66)	2.000 (50.80)	2.375 (60.33)	.177 (3.18)
39	1.734 (44.04)	2.062 (52.37)	2.328 (59.13)	.177 (3.18)
40	1.750 (44.45)	2.000 (50.80)	2.250 (57.15)	.219 (5.56)
41	1.906 (48.41)	2.250 (57.15)	2.625 (66.68)	.219 (5.56)
42	1.938 (49.23)	2.250 (57.15)	2.500 (63.50)	.219 (5.56)
43	2.188 (55.58)	2.500 (63.50)	2.750 (69.85)	.219 (5.56)
44	2.375 (60.33)	2.781 (70.64)	3.000 (76.20)	.219 (5.56)
45	2.406 (61.11)	2.750 (69.85)	3.125 (79.38)	.281 (7.14)
46	2.625 (66.68)	3.031 (76.99)	3.250 (82.55)	.219 (5.56)
47	2.656 (67.46)	3.000 (76.20)	3.375 (85.73)	.281 (7.14)
48	2.906 (73.81)	3.250 (82.55)	3.625 (92.08)	.281 (7.14)
49	3.156 (80.16)	3.500 (88.90)	3.875 (98.43)	.281 (7.14)

APPLICATION NOTES

1. Assembly identified with manufacturer's name and part number, space permitting.
2. For complete dimensions, see the applicable Military Specification.
3. Metric dimensions (mm) are in parentheses.

Dimensions in inches (millimeters) and are subject to change without notice.

Basic
Part Number

MS3420

Dash
Number

- 3

M85049/139 - 3

Material: Neoprene

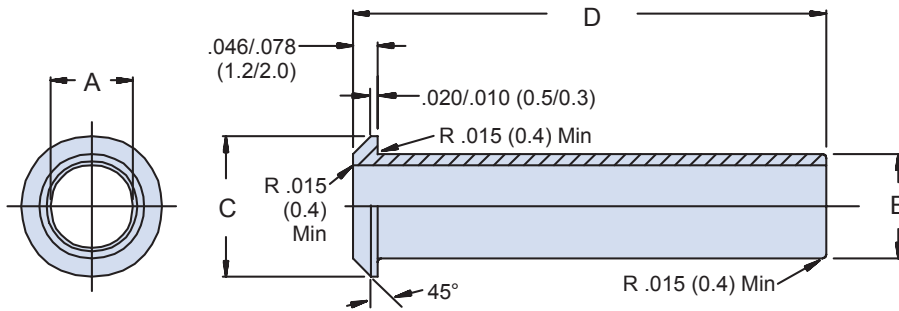

Basic
Part Number

MS3420

Dash
Number

- 3

L

Material

A = Neoprene
D = Silicone
L = Fluorosilicone

M85049/139

- 3

L

Material

A = Neoprene
D = Silicone
L = Fluorosilicone

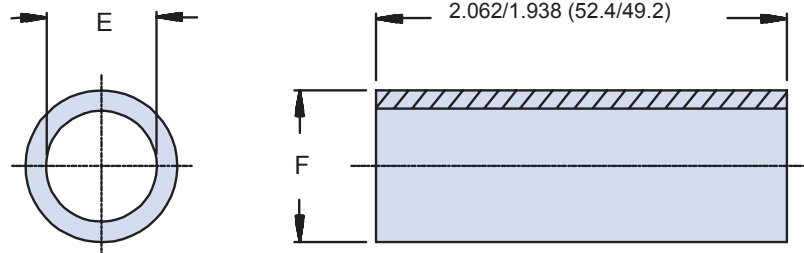

Dimensions in inches (millimeters) and are subject to change without notice.

MS3420 and AS85049/139 Telescoping Bushing



AS85049

B

TABLE I: Reference for Connector Shell Size

Dash No.	Ø A Dia	Ø B Dia	Ø C Dia	D Dim Dia	E Dia	F Dia
3	.150/.110 (3.8/2.8)	.230/.190 (5.8/4.8)	.395/.363 (10.0/9.2)	2.906/2.844 (73.8/72.2)	.150/.110 (3.8/2.8)	.230/.190 (5.8/4.8)
4	.240/.200 (6.1/5.1)	.322/.282 (8.2/7.2)	.521/.489 (13.2/12.4)	2.781/2.719 (70.6/69.1)	.240/.200 (6.1/5.1)	.322/.282 (8.2/7.2)
6	.332/.292 (8.4/7.4)	.447/.407 (11.4/10.3)	.635/.603 (16.1/15.3)	2.656/2.594 (67.5/65.9)	.332/.292 (8.4/7.4)	.447/.407 (11.4/10.3)
8	.464/.410 (11.8/10.4)	.579/.525 (14.7/13.3)	.760/.728 (19.3/18.5)	2.531/2.469 (64.3/62.7)	.464/.410 (11.8/10.4)	.579/.525 (14.7/13.3)
10	.589/.535 (15.0/13.6)	.652/.535 (16.6/13.6)	.905/.873 (23.0/59.5)	2.406/2.344 (61.1/10.4)	.464/.410 (11.8/10.4)	.642/.588 (16.3/14.9)
12	.652/.598 (16.6/15.2)	.767/.713 (19.5/18.1)	1.100/1.068 (27.9/27.1)	2.281/2.219 (57.9/56.4)	.568/.514 (14.4/13.1)	.767/.713 (19.5/18.1)
16	.777/.723 (19.7/18.4)	.954/.900 (24.2/22.9)	1.330/1.298 (33.8/33.0)	2.156/2.094 (54.8/53.2)	.777/.723 (19.7/18.4)	.954/.900 (24.2/22.9)
18	--	--	--	--	.976/.898 (24.8/22.8)	1.142/1.088 (29.0/27.6)
20	.976/.898 (24.8/22.8)	1.279/1.201 (32.5/30.5)	1.614/1.582 (41.0/40.2)	2.031/1.969 (51.6/50.0)	.976/.898 (24.8/22.8)	1.279/1.201 (32.5/30.5)
24	1.289/1.211 (32.7/30.8)	1.404/1.326 (35.7/33.7)	1.863/1.831 (47.3/46.5)	1.906/1.844 (48.4/46.8)	1.164/1.086 (29.6/27.6)	1.404/1.326 (35.7/33.7)
28	1.414/1.336 (35.9/33.9)	1.653/1.575 (42.0/40.0)	2.101/2.069 (53.4/52.6)	1.781/1.719 (45.2/43.7)	1.289/1.719 (45.2/43.7)	1.653/1.575 (42.0/40.0)
32	1.675/1.573 (42.5/40.0)	1.915/1.813 (48.6/46.1)	2.351/2.319 (59.7/58.9)	1.656/1.594 (42.1/40.0)	1.676/1.574 (42.6/40.0)	1.916/1.814 (48.7/46.1)
40	1.925/1.823 (48.9/46.3)	2.415/2.313 (61.3/58.8)	2.851/2.819 (72.4/71.6)	1.531/1.469 (38.9/37.3)	1.926/1.824 (48.9/46.3)	2.416/2.314 (61.4/58.8)

APPLICATION NOTES

1. Assembly identified with manufacturer's name and part number, space permitting.
2. For complete dimensions, see the applicable Military Specification.
3. Metric dimensions (mm) are in parentheses.

Dimensions in inches (millimeters) and are subject to change without notice.

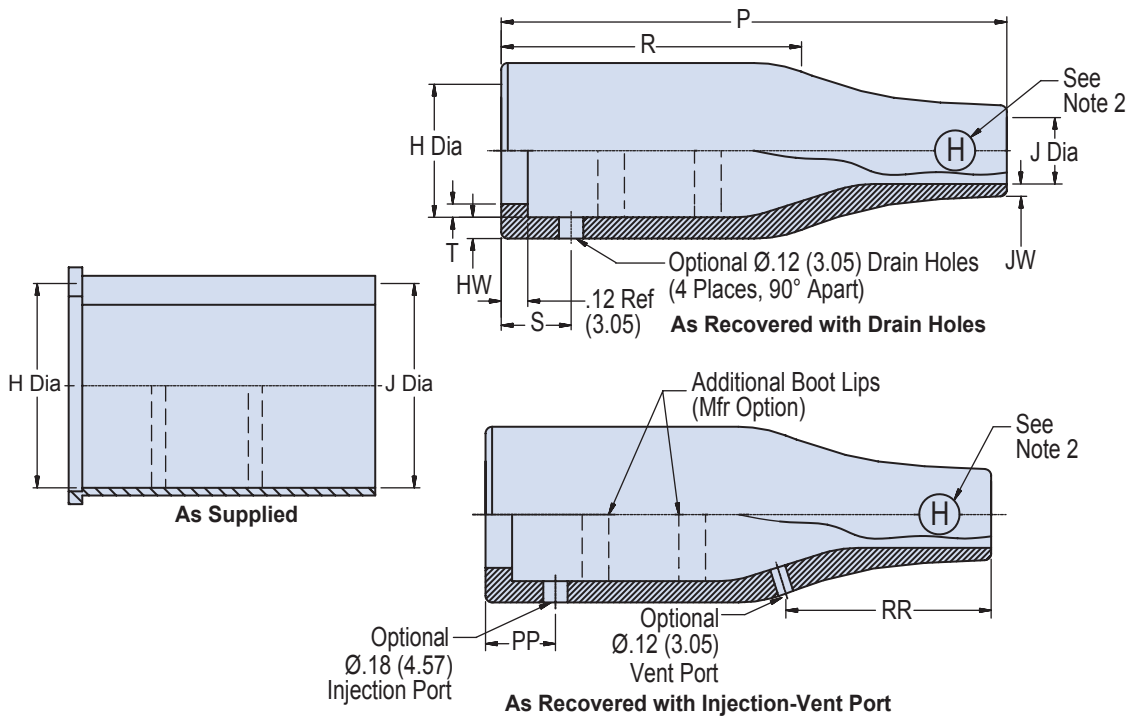
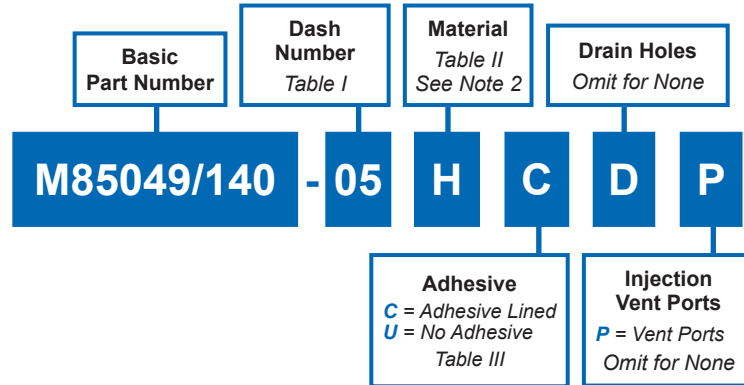

Dimensions in inches (millimeters) and are subject to change without notice.

AS85049/140 Straight Lipped Heat Shrink Boot



AS85049

B

TABLE I: Dash Number and Dimensions (Continued Below)

Dash No.	H Dia Min (As Supplied)	H Dia Max (As Recovered)	J Dia Min (As Supplied) Material A, B, H	J Dia Min (As Supplied) Material G	J Dia Max (As Recovered)	P (As Recovered) ±10%	R (As Recovered) Ref
01	0.92 (23.4)	0.41 (10.4)	0.92 (23.4)	0.47 (11.9)	0.24 (6.1)	1.50 (38.1)	0.83 (21.1)
02	1.12 (28.4)	0.56 (14.2)	1.12 (28.4)	0.58 (14.7)	0.26 (6.6)	2.16 (54.9)	1.09 (27.7)
03	1.22 (31.0)	0.70 (17.6)	1.22 (31.0)	0.63 (16.0)	0.28 (7.1)	2.63 (66.8)	1.39 (35.3)
04	1.42 (36.1)	0.88 (22.4)	1.42 (36.1)	0.73 (18.5)	0.38 (9.7)	3.15 (80.0)	1.63 (41.4)
05	1.68 (42.7)	1.11 (28.2)	1.68 (42.7)	0.87 (22.1)	0.39 (9.9)	4.08 (103.6)	2.22 (56.4)
06	2.04 (51.8)	1.38 (35.1)	2.04 (51.8)	1.39 (35.3)	0.63 (16.0)	5.13 (130.3)	2.54 (64.5)
07	2.60 (66.0)	1.75 (44.5)	2.60 (66.0)	1.80 (45.7)	0.80 (20.3)	6.50 (165.1)	3.31 (84.1)
08	3.22 (81.8)	2.27 (57.7)	3.22 (81.8)	2.25 (57.2)	1.00 (25.4)	7.00 (177.8)	3.75 (95.3)

TABLE I: Dash Number and Dimensions (Continued from Above)

Dash No.	T (As Recovered) Ref	HW (As Recovered) ±20%	JW Max (As Recovered)	PP (As Recovered) ±10%	S (As Recovered) ±10%	RR (As Recovered) ±10%
01	0.04 (1.0)	0.07 (1.8)	0.09 (2.2)	0.60 (15.2)	0.48 (12.2)	N/A
02	0.04 (1.0)	0.07 (1.8)	0.09 (2.2)	0.60 (15.2)	0.49 (12.4)	.85 (21.6)
03	0.04 (1.0)	0.08 (2.0)	0.10 (2.5)	0.60 (15.2)	0.75 (19.1)	.96 (24.4)
04	0.04 (1.0)	0.08 (2.0)	0.10 (2.5)	0.60 (15.2)	0.75 (19.1)	1.17 (29.7)
05	0.07 (1.8)	0.09 (2.3)	0.11 (2.7)	0.60 (15.2)	0.75 (19.1)	1.44 (36.6)
06	0.07 (1.8)	0.13 (3.3)	0.16 (4.0)	0.60 (15.2)	0.57 (14.5)	2.12 (53.8)
07	0.08 (2.0)	0.16 (4.1)	0.19 (4.9)	0.60 (15.2)	0.68 (17.3)	2.59 (65.8)
08	0.08 (2.0)	0.16 (4.1)	0.19 (4.9)	0.60 (15.2)	0.68 (17.3)	2.64 (67.1)

TABLE II: Shrink Boot Materials

Material Code	Compound	Material Description	Color Code
A	2071	Flexible Polyolefin	WHITE
B	2040	General Purpose Polyolefin	RED
G	2010	Zero Halogen Polyolefin	GREEN
H	2025	High Performance Elastomer	BLUE

TABLE III: Adhesive Description

Symbol	Adhesive Description
C	Zero Halogen / Hot Melt

APPLICATION NOTES

1. See bag identification for matching boot number, not number on boot. See part number development for full description.
2. Encircled material letter designator located on O.D. approximately mid length along the "J" end. See part number development for full description.
3. Metric dimensions (mm) are in parentheses.

Dimensions in inches (millimeters) and are subject to change without notice.

AS85049/140 Straight Lipped Long Tail Low Profile Heat Shrink Boot

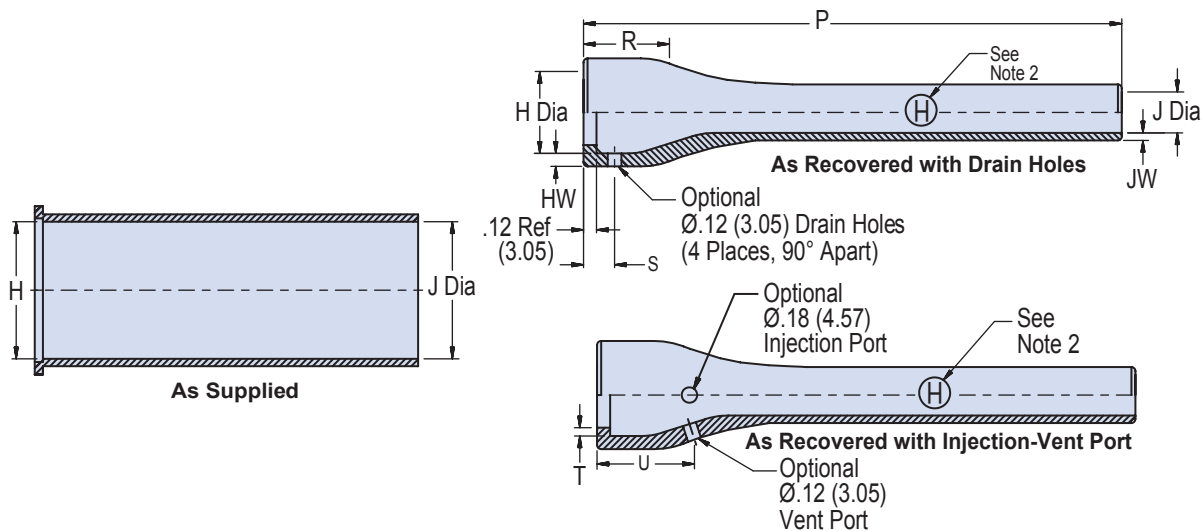
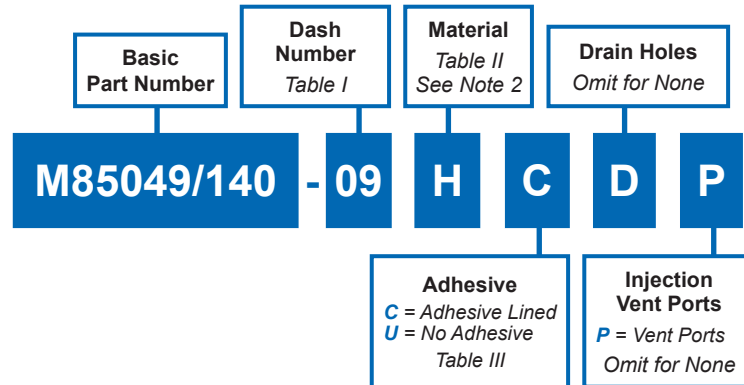

Dimensions in inches (millimeters) and are subject to change without notice.

AS85049/140

Straight Lipped Long Tail Low Profile Heat Shrink Boot



AS85049

B

TABLE I: Dash Number and Dimensions (Continued Below)

Dash No.	H Dia Min (As Supplied)	H Dia Max (As Recovered)	J Dia Min (As Supplied) Material A, B, H	J Dia Min (As Recovered) Material G	J Dia Max (As Recovered)	P (As Recovered) ±10%	R (As Recovered) Ref
09	0.88 (22.4)	0.47 (11.9)	0.88 (22.4)	0.55 (14.0)	0.25 (6.4)	4.17 (105.9)	0.46 (11.7)
10	0.98 (24.9)	0.59 (15.0)	0.98 (24.9)	0.63 (16.0)	0.30 (7.6)	4.77 (121.2)	0.48 (12.2)
11	1.16 (29.5)	0.75 (19.1)	1.16 (29.5)	0.72 (18.3)	0.33 (8.4)	5.46 (138.7)	0.48 (12.2)
12	1.34 (34.0)	0.91 (23.1)	1.34 (34.0)	0.84 (21.3)	0.39 (9.9)	6.28 (159.5)	0.48 (12.2)
13	1.47 (37.3)	1.18 (30.0)	1.47 (37.3)	0.91 (23.1)	0.43 (10.9)	7.00 (177.8)	0.55 (14.0)
14	1.72 (43.7)	1.34 (34.0)	1.72 (43.7)	1.07 (27.2)	0.48 (12.2)	8.00 (203.2)	0.60 (15.2)
15	1.97 (50.0)	1.62 (41.1)	1.97 (50.0)	1.24 (31.5)	0.57 (14.5)	8.00 (203.2)	0.60 (15.2)
16	2.47 (62.7)	1.85 (47.0)	2.47 (62.7)	1.54 (39.1)	0.71 (18.0)	8.00 (203.2)	0.63 (16.0)
17	2.73 (69.3)	2.36 (59.9)	2.73 (69.3)	1.70 (43.2)	0.79 (20.1)	8.00 (203.2)	0.63 (16.0)
18	3.22 (81.8)	2.64 (67.1)	3.22 (81.8)	2.01 (51.1)	0.91 (23.1)	8.00 (203.2)	0.63 (16.0)

TABLE I: Dash Number and Dimensions (Continued from Above)

Dash No.	T (As Recovered) Ref	HW (As Recovered) ±20%	JW Max (As Recovered)	S (As Recovered) ±10%	U (As Recovered) ±10%
09	0.04 (1.0)	0.06 (1.5)	0.05 (1.1)	0.23 (5.8)	0.56 (14.2)
10	0.04 (1.0)	0.06 (1.5)	0.05 (1.1)	0.24 (6.1)	0.59 (15.0)
11	0.04 (1.0)	0.07 (1.8)	0.05 (1.1)	0.47 (11.9)	0.61 (15.5)
12	0.04 (1.0)	0.07 (1.8)	0.05 (1.1)	0.47 (11.9)	0.62 (15.7)
13	0.07 (1.7)	0.08 (2.0)	0.05 (1.1)	0.47 (11.9)	0.71 (18.0)
14	0.07 (1.7)	0.08 (2.0)	0.05 (1.1)	0.47 (11.9)	0.78 (19.8)
15	0.07 (1.7)	0.09 (2.3)	0.06 (1.5)	0.30 (7.6)	0.82 (20.8)
16	0.08 (2.0)	0.10 (2.5)	0.06 (1.5)	0.63 (16.0)	0.92 (23.4)
17	0.08 (2.0)	0.10 (2.5)	0.06 (1.5)	0.63 (16.0)	0.93 (23.6)
18	0.08 (2.0)	0.10 (2.5)	0.06 (1.5)	0.63 (16.0)	1.23 (31.2)

TABLE II: Shrink Boot Materials

Material Code	Compound	Material Description	Color Code
A	2071	Flexible Polyolefin	WHITE
B	2040	General Purpose Polyolefin	RED
G	2010	Zero Halogen Polyolefin	GREEN
H	2025	High Performance Elastomer	BLUE

TABLE III: Adhesive Description

Symbol	Adhesive Description
C	Zero Halogen / Hot Melt

APPLICATION NOTES

1. See bag identification for matching boot number, not number on boot. See part number development for full description.
2. Encircled material letter designator located on O.D. approximately mid length along the "J" end. See part number development for full description.
3. Metric dimensions (mm) are in parentheses.

Dimensions in inches (millimeters) and are subject to change without notice.

AS85049/140

Straight Lipped Miniature Long Tail High Ratio Low Profile Heat Shrink Boot

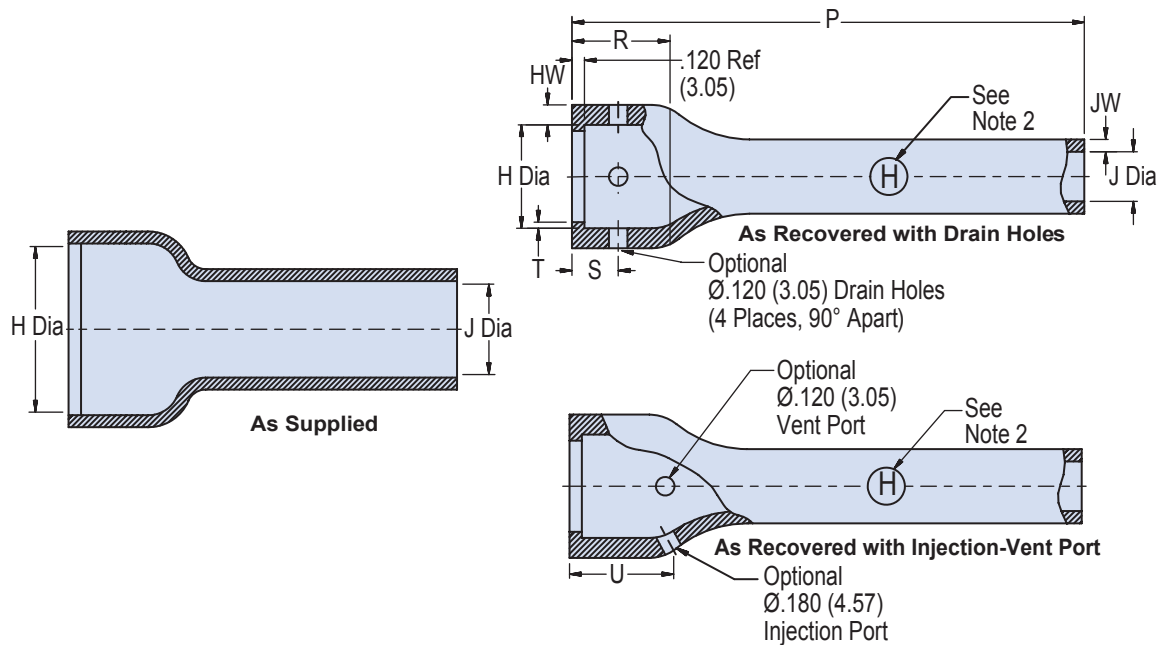
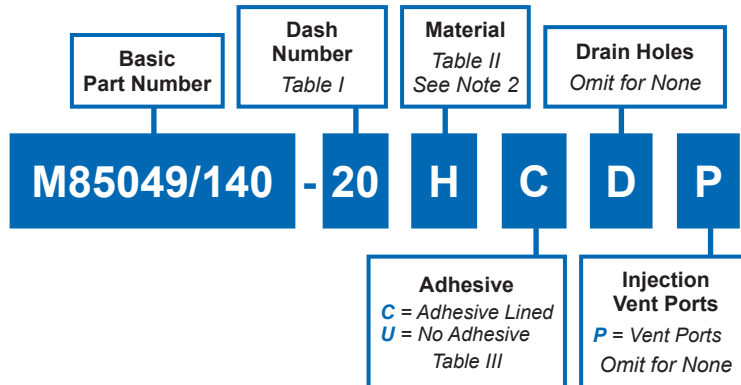

Dimensions in inches (millimeters) and are subject to change without notice.

AS85049/140

Straight Lipped Miniature Long Tail High Ratio Low Profile Heat Shrink Boot



AS85049

B

TABLE I: Dash Number and Dimensions (Continued Below)

Dash No.	H Dia Min (As Supplied)	H Dia Max (As Recovered)	J Dia Min (As Supplied) Material A, B, H	J Dia Min (As Supplied) Material G	J Dia Max (As Recovered)	P (As Recovered) ±10%	R (As Recovered) Ref
19	0.76 (19.3)	0.51 (13.0)	0.25 (6.4)	0.18 (4.6)	0.08 (2.0)	2.37 (60.2)	0.46 (11.7)
20	1.03 (26.2)	0.75 (19.1)	0.30 (7.6)	0.22 (5.6)	0.10 (2.5)	2.92 (74.2)	0.48 (12.2)
21	1.35 (34.3)	1.02 (25.9)	0.38 (9.7)	0.26 (6.6)	0.12 (3.0)	3.32 (84.3)	0.48 (12.2)
22	1.72 (43.7)	1.34 (34.0)	0.45 (11.4)	0.31 (7.9)	0.14 (3.6)	3.92 (99.6)	0.48 (12.2)

TABLE I: Dash Number and Dimensions (Continued from Above)

Dash No.	T (As Recovered) ±10%	HW (As Recovered) ±20%	JW Max (As Recovered)	S (As Recovered) ±10%	U (As Recovered) ±10%
19	0.04 (1.0)	0.06 (1.5)	0.05 (1.14)	0.47 (11.9)	0.62 (15.75)
20	0.04 (1.0)	0.07 (1.8)	0.05 (1.14)	0.47 (11.9)	0.80 (20.32)
21	0.04 (1.0)	0.07 (1.8)	0.05 (1.14)	0.47 (11.9)	0.90 (22.86)
22	0.07 (1.7)	0.07 (1.8)	0.05 (1.14)	0.47 (11.9)	1.03 (26.16)

TABLE II: Shrink Boot Materials

Material Code	Compound	Material Description	Color Code
A	2071	Flexible Polyolefin	WHITE
B	2040	General Purpose Polyolefin	RED
G	2010	Zero Halogen Polyolefin	GREEN
H	2025	High Performance Elastomer	BLUE

TABLE III: Adhesive Description

Symbol	Adhesive Description
C	Zero Halogen / Hot Melt

APPLICATION NOTES

1. See bag identification for matching boot number, not number on boot. See part number development for full description.
2. Encircled material letter designator located on O.D. approximately mid length along the "J" end. See part number development for full description.
3. Metric dimensions (mm) are in parentheses.

Dimensions in inches (millimeters) and are subject to change without notice.

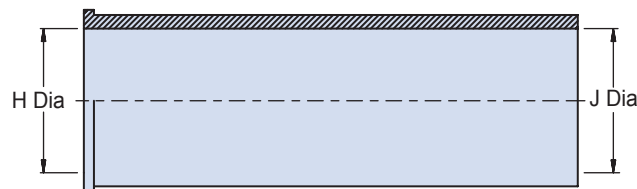
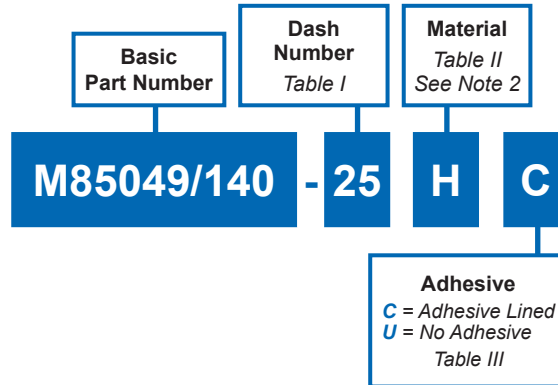

As Supplied

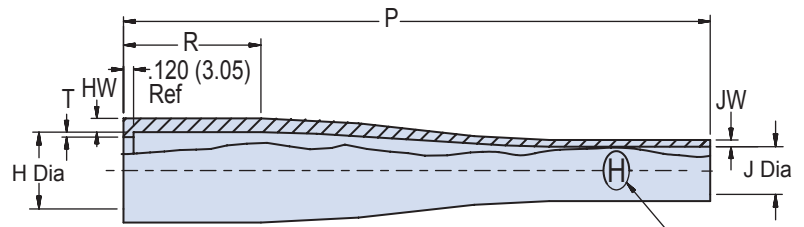

As Recovered

See Note 2

Dimensions in inches (millimeters) and are subject to change without notice.

AS85049/140 Straight Lipped Sealing Heat Shrink Boot



AS85049

B

TABLE I: Dash Number and Dimensions

Dash No.	H Dia Min (As Supplied)	H Dia Max (As Recovered)	J Dia Min (As Supplied)	J Dia Max (As Recovered)	P (As Recovered) ±10%	R (As Recovered) Ref	T (As Recovered) ±10%	HW (As Recovered) ±20%	JW Max (As Recovered)
23	0.84 (21.3)	0.55 (14.0)	0.66 (16.8)	0.21 (5.3)	5.30 (134.6)	1.10 (27.9)	0.06 (1.5)	0.16 (4.1)	0.04 (1.0)
24	1.00 (25.4)	0.65 (16.5)	1.00 (25.4)	0.33 (8.4)	6.00 (152.4)	1.20 (30.5)	0.06 (1.5)	0.16 (4.1)	0.06 (1.5)
25	1.30 (33.0)	0.80 (20.3)	1.30 (33.0)	0.43 (10.9)	6.00 (152.4)	1.20 (30.5)	0.06 (1.5)	0.16 (4.1)	0.06 (1.5)
26	1.70 (43.2)	0.90 (22.9)	1.70 (43.2)	0.56 (14.2)	6.90 (175.3)	1.50 (38.1)	0.06 (1.5)	0.16 (4.1)	0.08 (2.0)
27	2.10 (53.3)	1.10 (27.9)	2.10 (53.3)	0.70 (17.8)	6.90 (175.3)	1.50 (38.1)	0.06 (1.5)	0.16 (4.1)	0.08 (2.0)
28	2.85 (72.4)	1.45 (36.4)	2.85 (72.4)	0.95 (24.1)	7.24 (183.9)	1.60 (40.6)	0.06 (1.5)	0.20 (5.1)	0.10 (2.54)

TABLE II: Shrink Boot Materials

Material Code	Compound	Material Description	Color Code
A	2071	Flexible Polyolefin	WHITE
B	2040	General Purpose Polyolefin	RED
G	2010	Zero Halogen Polyolefin	GREEN
H	2025	High Performance Elastomer	BLUE

TABLE III: Adhesive Description

Symbol	Adhesive Description
C	Zero Halogen / Hot Melt

APPLICATION NOTES

1. See bag identification for matching boot number, not number on boot. See part number development for full description.
2. Encircled material letter designator located on O.D. approximately mid length along the "J" end. See part number development for full description.
3. Metric dimensions (mm) are in parentheses.

Dimensions in inches (millimeters) and are subject to change without notice.

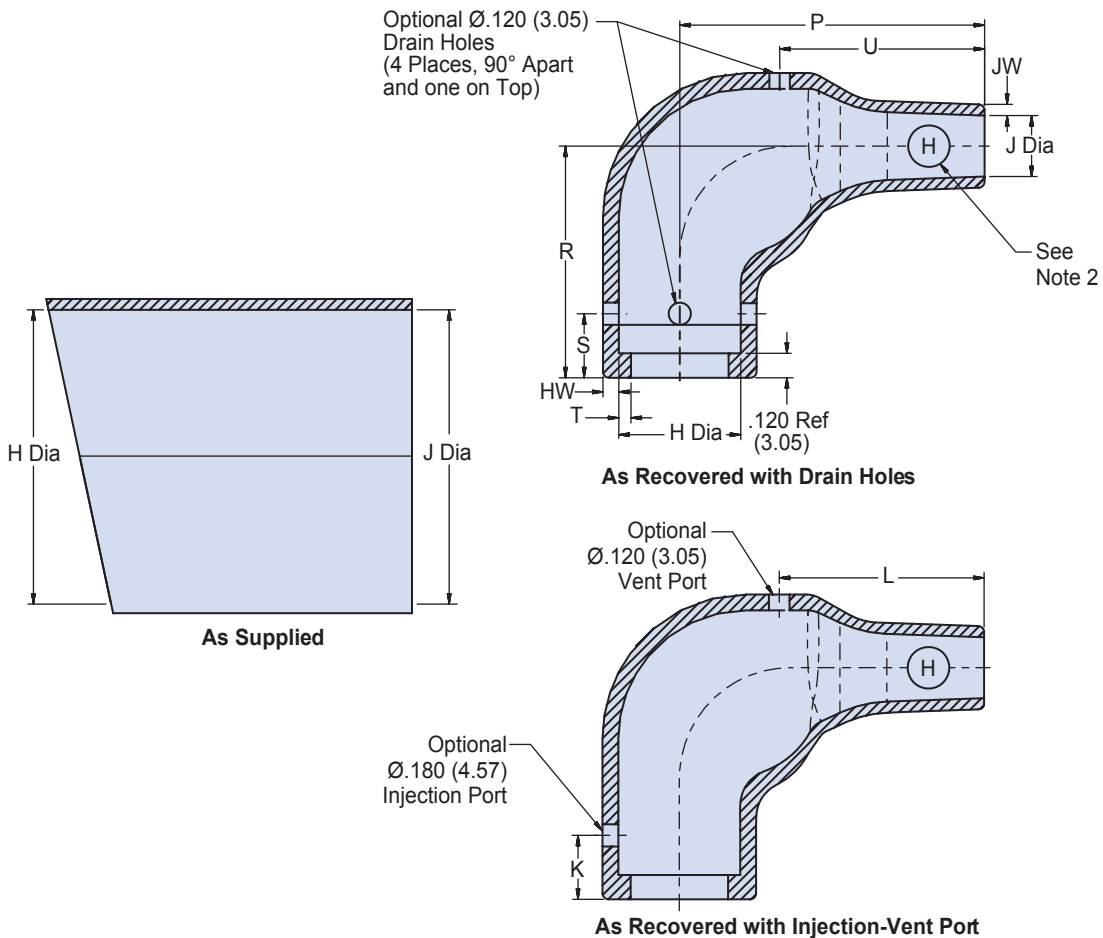
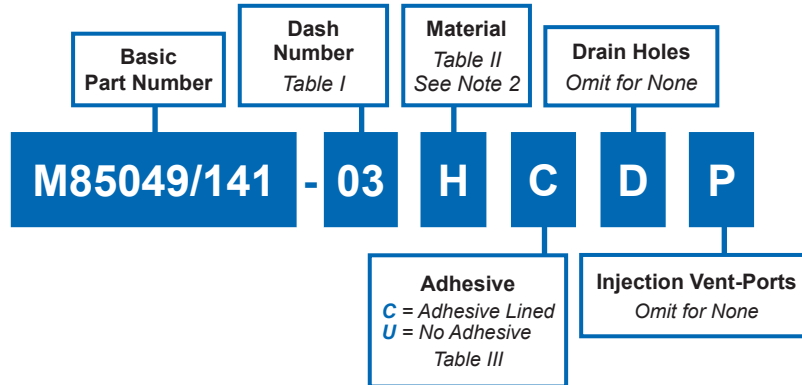

Dimensions in inches (millimeters) and are subject to change without notice.

AS85049/141 90° Lipped Heat Shrink Boot

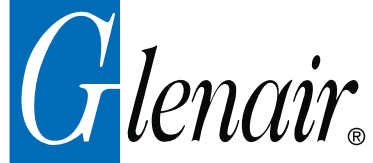

AS85049

B

TABLE I: Dash Number and Dimensions (Continued Below)

Dash No.	H Dia Min (As Supplied)	H Dia Max (As Recovered)	J Dia Min (As Supplied) Material A, B, H	J Dia Min (As Supplied) Material G	J Dia Max (As Recovered)	P (As Recovered) ±10%	R (As Recovered) ±10%
01	0.920 (23.4)	0.410 (10.4)	0.920 (23.4)	0.470 (11.9)	0.240 (6.1)	0.840 (21.3)	0.650 (16.5)
02	1.120 (28.4)	0.610 (15.5)	1.120 (28.4)	0.580 (14.7)	0.260 (6.6)	1.330 (33.8)	0.760 (19.3)
03	1.220 (31.0)	0.710 (18.0)	1.220 (31.0)	0.630 (16.0)	0.280 (7.1)	1.440 (36.6)	0.830 (21.1)
04	1.420 (36.1)	0.890 (22.6)	1.420 (36.1)	0.730 (18.5)	0.330 (8.4)	1.720 (43.7)	0.900 (22.9)
05	1.680 (42.7)	1.120 (28.4)	1.680 (42.7)	0.870 (22.1)	0.390 (9.9)	2.110 (53.6)	1.140 (29.0)
06	2.040 (51.8)	1.380 (35.1)	2.040 (51.8)	1.390 (35.3)	0.630 (16.0)	3.070 (78.0)	1.320 (33.5)
07	2.600 (66.0)	1.770 (45.0)	2.600 (66.0)	1.800 (45.7)	0.800 (20.3)	3.840 (97.5)	1.640 (41.7)
08	3.220 (81.8)	2.400 (61.0)	3.220 (81.8)	2.250 (57.2)	1.000 (25.4)	4.640 (117.9)	2.030 (51.6)

TABLE I: Dash Number and Dimensions (Continued from Above)

Dash No.	T (As Recovered) Ref	HW (As Recovered) ±20%	JW Max (As Recovered)	S (As Recovered) ±10%	U (As Recovered) ±10%	K (As Recovered) ±10%	L (As Recovered) ±10%
01	0.040 (1.0)	0.050 (1.3)	0.050 (1.3)	0.450 (11.4)	0.470 (11.9)	0.600 (15.2)	0.580 (14.7)
02	0.040 (1.0)	0.060 (1.5)	0.050 (1.3)	0.470 (11.9)	1.020 (25.9)	0.750 (19.1)	0.980 (24.9)
03	0.040 (1.0)	0.070 (1.8)	0.070 (1.8)	0.470 (11.9)	1.090 (27.7)	0.750 (19.1)	0.980 (24.9)
04	0.040 (1.0)	0.070 (1.8)	0.070 (1.8)	0.470 (11.9)	1.160 (29.5)	0.750 (19.1)	1.180 (30.0)
05	0.070 (1.8)	0.080 (2.0)	0.080 (2.0)	0.470 (11.9)	1.470 (37.3)	0.760 (19.3)	1.300 (33.0)
06	0.070 (1.8)	0.130 (3.3)	0.130 (3.3)	0.530 (13.5)	2.500 (63.5)	1.000 (25.4)	2.120 (53.8)
07	0.080 (2.0)	0.150 (3.8)	0.150 (3.8)	0.640 (16.3)	2.750 (69.9)	1.000 (25.4)	2.800 (71.1)
08	0.080 (2.0)	0.160 (4.1)	0.160 (4.1)	0.640 (16.3)	3.120 (79.2)	1.000 (25.4)	3.150 (80.0)

TABLE II: Shrink Boot Materials

Material Code	Compound	Material Description	Color Code
A	2071	Flexible Polyolefin	WHITE
B	2040	General Purpose Polyolefin	RED
G	2010	Zero Halogen Polyolefin	GREEN
H	2025	High Performance Elastomer	BLUE

TABLE III: Adhesive Description

Symbol	Adhesive Description
C	Zero Halogen / Hot Melt

APPLICATION NOTES

1. See bag identification for matching boot number, not number on boot. See part number development for full description.
2. Encircled material letter designator located on O.D. approximately mid length along the "J" end. See part number development for full description.
3. Metric dimensions (mm) are in parentheses.

Dimensions in inches (millimeters) and are subject to change without notice.

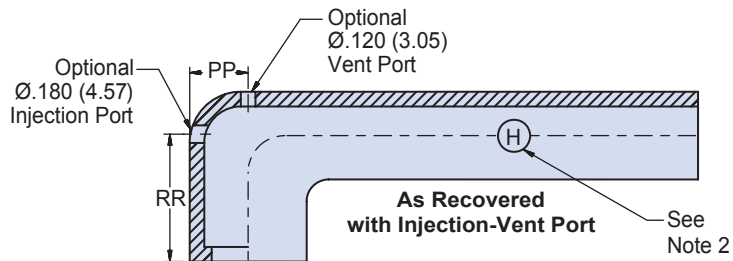
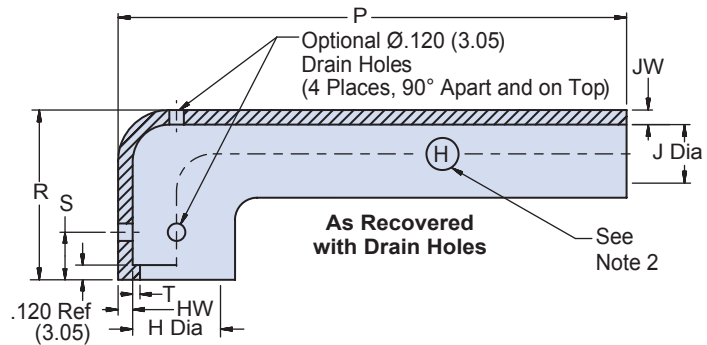
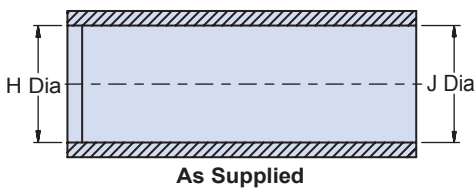
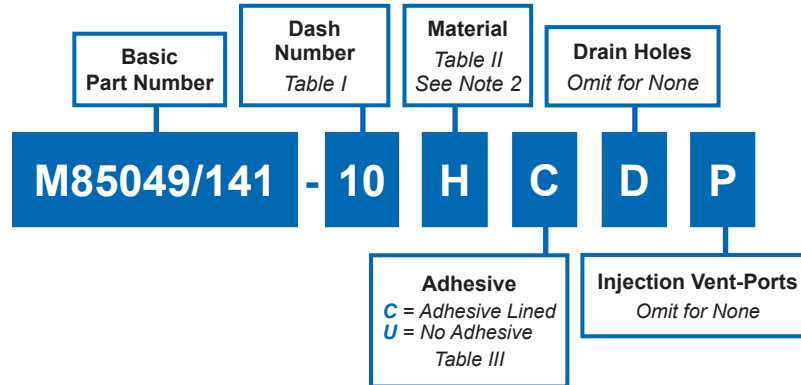

Dimensions in inches (millimeters) and are subject to change without notice.

AS85049/141 90° Lipped Low Profile Heat Shrink Boot



AS85049

B

TABLE I: Dash Number and Dimensions (Continued Below)

Dash No.	H Dia Min (As Supplied)	H Dia Max (As Recovered)	J Dia Min (As Supplied) Material A, B, H	J Dia Max (As Supplied) Material G	J Dia Max (As Recovered)	P (As Recovered) ±10%	R (As Recovered) Ref
09	0.880 (22.4)	0.450 (11.4)	0.880 (22.4)	0.550 (14.0)	0.250 (6.4)	4.140 (105.2)	0.730 (18.5)
10	1.010 (25.7)	0.590 (15.0)	1.010 (25.7)	0.630 (16.0)	0.300 (7.6)	4.880 (124.0)	0.780 (19.8)
11	1.160 (29.5)	0.740 (18.8)	1.160 (29.5)	0.720 (18.3)	0.330 (8.4)	5.760 (146.3)	0.820 (20.8)
12	1.340 (34.0)	0.900 (22.9)	1.340 (34.0)	0.840 (21.3)	0.390 (9.9)	6.780 (172.2)	0.860 (21.8)
13	1.470 (37.3)	1.160 (29.5)	1.470 (37.3)	0.910 (23.1)	0.430 (10.9)	7.290 (185.2)	0.960 (24.4)
14	1.720 (43.7)	1.340 (34.0)	1.720 (43.7)	1.070 (27.2)	0.480 (12.2)	8.410 (213.6)	1.080 (27.4)
15	1.970 (50.0)	1.620 (41.1)	1.970 (50.0)	1.240 (31.5)	0.570 (14.5)	8.840 (224.5)	1.160 (29.5)
16	2.470 (62.7)	1.850 (47.0)	2.470 (62.7)	1.540 (39.1)	0.710 (18.0)	8.950 (227.3)	1.310 (33.3)
17	2.730 (69.3)	2.350 (59.7)	2.730 (69.3)	1.700 (43.2)	0.790 (20.1)	9.190 (233.4)	1.380 (35.1)
18	3.220 (81.8)	2.640 (67.1)	3.220 (81.8)	2.010 (51.1)	0.910 (23.1)	9.330 (237.0)	1.750 (44.5)

TABLE I: Dash Number and Dimensions (Continued from Above)

Dash No.	T (As Recovered) Ref	HW (As Recovered) ±20%	JW Max (As Recovered)	S (As Recovered) ±10%	PP (As Recovered) ±10%	RR (As Recovered) ±10%
09	0.040 (1.0)	0.060 (1.5)	0.060 (1.5)	0.470 (11.9)	0.270 (6.9)	0.490 (12.4)
10	0.040 (1.0)	0.060 (1.5)	0.060 (1.5)	0.470 (11.9)	0.330 (8.4)	0.590 (15.0)
11	0.040 (1.0)	0.070 (1.8)	0.060 (1.5)	0.470 (11.9)	0.410 (10.4)	0.610 (15.5)
12	0.040 (1.0)	0.070 (1.8)	0.060 (1.5)	0.470 (11.9)	0.480 (12.2)	0.620 (15.7)
13	0.070 (1.8)	0.080 (2.0)	0.060 (1.5)	0.470 (11.9)	0.610 (15.5)	0.700 (17.8)
14	0.070 (1.8)	0.080 (2.0)	0.060 (1.5)	0.470 (11.9)	0.720 (18.3)	0.780 (19.8)
15	0.070 (1.8)	0.090 (2.3)	0.060 (1.5)	0.470 (11.9)	0.830 (21.1)	0.820 (20.8)
16	0.080 (2.0)	0.100 (2.5)	0.060 (1.5)	0.630 (16.0)	0.950 (24.1)	0.920 (23.4)
17	0.080 (2.0)	0.100 (2.5)	0.060 (1.5)	0.630 (16.0)	1.180 (30.0)	0.930 (23.6)
18	0.080 (2.0)	0.100 (2.5)	0.060 (1.5)	0.630 (16.0)	1.310 (33.3)	1.230 (31.2)

TABLE II: Shrink Boot Materials

Material Code	Compound	Material Description	Color Code
A	2071	Flexible Polyolefin	WHITE
B	2040	General Purpose Polyolefin	RED
G	2010	Zero Halogen Polyolefin	GREEN
H	2025	High Performance Elastomer	BLUE

TABLE III: Adhesive Description

Symbol	Adhesive Description
C	Zero Halogen / Hot Melt

APPLICATION NOTES

1. See bag identification for matching boot number, not number on boot. See part number development for full description.
2. Encircled material letter designator located on O.D. approximately mid length along the "J" end. See part number development for full description.
3. Metric dimensions (mm) are in parentheses.

Dimensions in inches (millimeters) and are subject to change without notice.

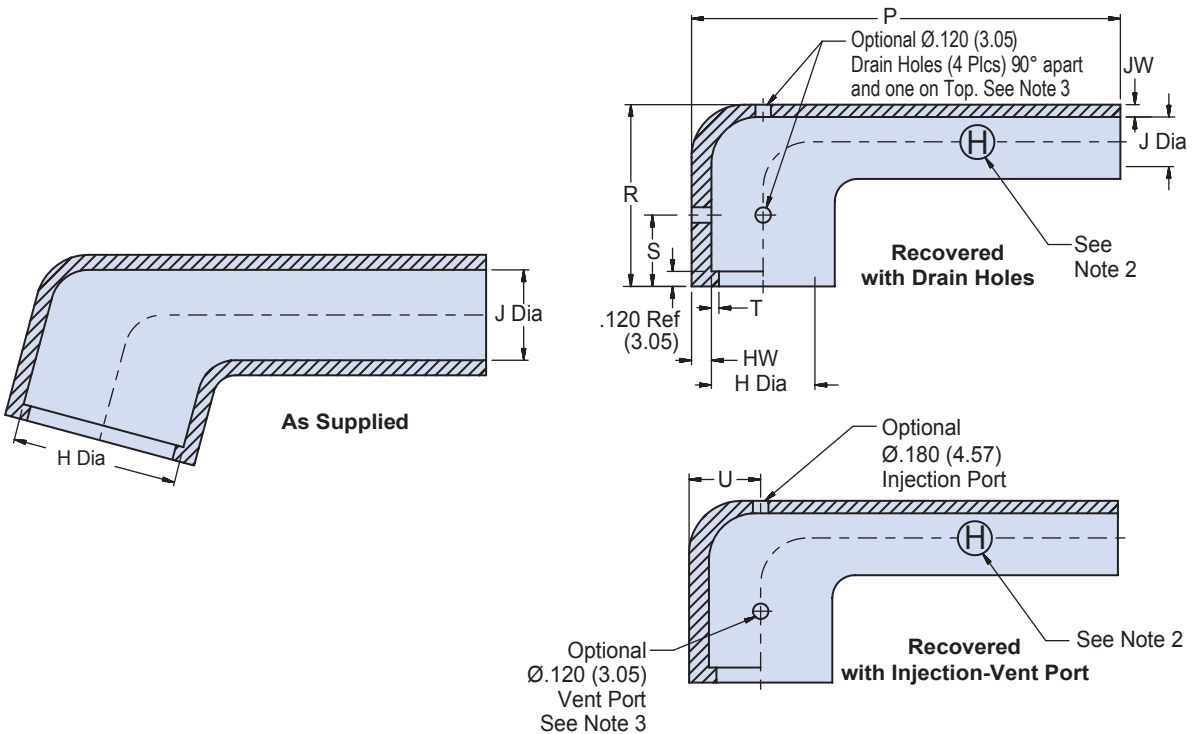
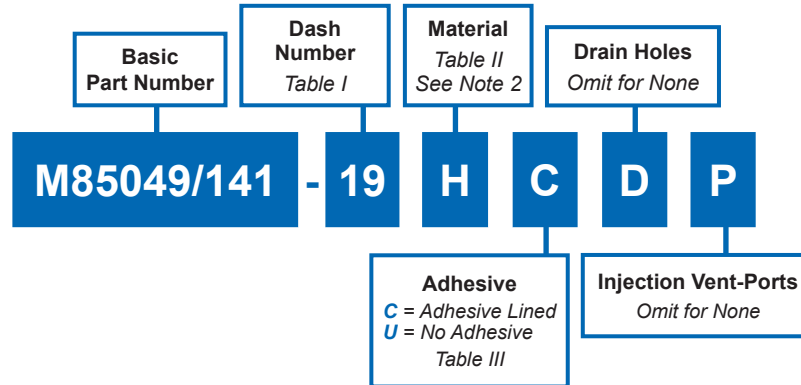

Dimensions in inches (millimeters) and are subject to change without notice.

AS85049/141

90° Lipped Miniature Low Profile Heat Shrink Boot



AS85049

B

TABLE I: Dash Number and Dimensions (Continued Below)

Dash No.	H Dia Min (As Supplied)	H Dia Max (As Recovered)	J Dia Min (As Supplied) Material A, B, H	J Dia Max (As Supplied) Material G	J Dia Max (As Recovered)	P (As Recovered) ±10%	R (As Recovered) Ref
19	0.760 (19.3)	0.510 (13.0)	0.250 (6.4)	0.180 (4.6)	0.080 (2.0)	1.750 (44.5)	0.640 (16.3)
20	1.030 (26.2)	0.750 (19.1)	0.300 (7.6)	0.220 (5.6)	0.100 (2.5)	2.650 (67.3)	0.710 (18.0)
21	1.350 (34.3)	1.020 (25.9)	0.380 (9.7)	0.260 (6.6)	0.120 (3.0)	3.200 (81.3)	0.740 (18.8)
22	1.720 (43.7)	1.340 (34.0)	0.450 (11.4)	0.310 (7.9)	0.140 (3.6)	4.550 (115.6)	0.840 (21.3)

TABLE I: Dash Number and Dimensions (Continued from Above)

Dash No.	T (As Recovered) Ref	HW (As Recovered) ±20%	JW Max (As Recovered)	S (As Recovered) ±10%	U (As Recovered) ±10%
19	0.040 (1.0)	0.060 (1.5)	0.050 (1.1)	0.470 (11.90)	0.220 (5.6)
20	0.040 (1.0)	0.070 (1.8)	0.050 (1.1)	0.470 (11.90)	0.330 (8.4)
21	0.040 (1.0)	0.070 (1.8)	0.050 (1.1)	0.470 (11.90)	0.450 (11.4)
22	0.070 (1.8)	0.070 (1.8)	0.050 (1.1)	0.470 (11.90)	0.610 (15.5)

TABLE II: Shrink Boot Materials

Material Code	Compound	Material Description	Color Code
A	2071	Flexible Polyolefin	WHITE
B	2040	General Purpose Polyolefin	RED
G	2010	Zero Halogen Polyolefin	GREEN
H	2025	High Performance Elastomer	BLUE

TABLE III: Adhesive Description

Symbol	Adhesive Description
C	Zero Halogen / Hot Melt

APPLICATION NOTES

1. See bag identification for matching boot number, not number on boot. See part number development for full description.
2. Encircled material letter designator located on O.D. approximately mid length along the "J" end. See part number development for full description.
3. Dimensions applicable for both injection and vent ports.
4. Metric dimensions (mm) are in parentheses.

Dimensions in inches (millimeters) and are subject to change without notice.

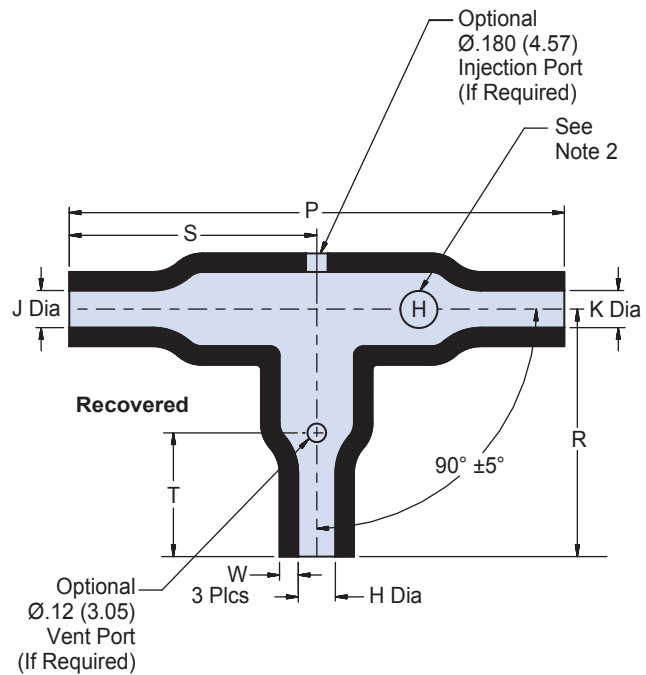
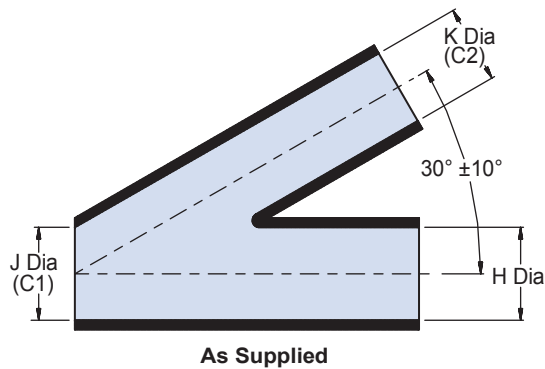
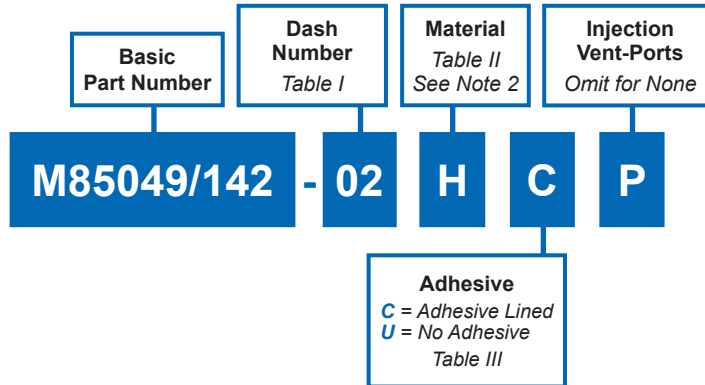

Dimensions in inches (millimeters) and are subject to change without notice.

AS85049/142 Tee Transition Wide Body Heat Shrink Boot



AS85049

B

TABLE I: Dash Number and Dimension

Dash No.	H, J, K Dia Min (As Supplied)	H, J, K Dia Max (As Recovered)	P (As Recovered) ±10%	R (As Recovered) ±10%	S (As Recovered) ±10%	T (As Recovered) ±10%	W (As Recovered) ±20%
01	0.260 (6.6)	0.140 (3.6)	1.170 (29.7)	0.580 (14.7)	0.590 (15.0)	N/A	0.040 (1.0)
02	0.520 (13.2)	0.270 (6.9)	2.310 (58.7)	1.160 (29.5)	1.160 (29.5)	0.690 (17.5)	0.060 (1.5)
03	1.060 (26.9)	0.530 (13.5)	4.730 (120.1)	2.360 (59.9)	2.370 (60.2)	1.400 (35.6)	0.090 (2.3)
04	2.190 (55.6)	1.190 (30.2)	9.700 (246.4)	4.850 (123.2)	4.850 (123.2)	2.790 (70.9)	0.120 (3.0)

TABLE II: Shrink Boot Materials

Material Code	Compound	Material Description	Color Code
A	2071	Flexible Polyolefin	WHITE
B	2040	General Purpose Polyolefin	RED
G	2010	Zero Halogen Polyolefin	GREEN
H	2025	High Performance Elastomer	BLUE

TABLE III: Adhesive Description

Symbol	Adhesive Description
C	Zero Halogen / Hot Melt

APPLICATION NOTES

1. See bag identification for matching boot number, matching dash number on boot. See part number development for full description.
2. Encircled material letter designator located on O.D. approximately mid length along the "K" end. See part number development for full description.
3. Metric dimensions (mm) are in parentheses.

Dimensions in inches (millimeters) and are subject to change without notice.

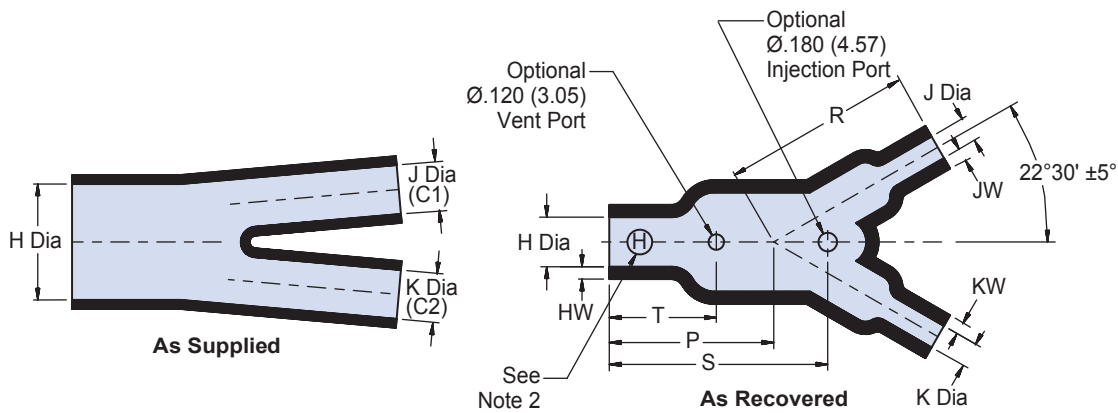
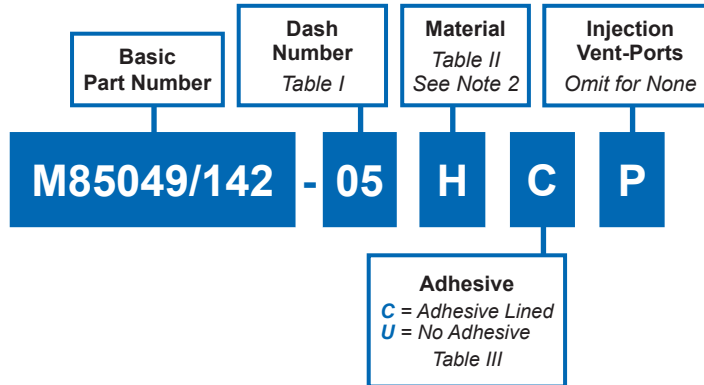

Dimensions in inches (millimeters) and are subject to change without notice.

AS85049/142 Wye Transition Wide Body Heat Shrink Boot



AS85049

TABLE I: Dash Number and Dimensions

Dash No.	H Dia Min (As Supplied)	H Dia Max (As Recovered)	J & K Dia Min (As Supplied)	J & K Dia Max (As Recovered)	P (As Recovered) Ref	R (As Recovered) Ref	S (As Recovered) ±10%	T (As Recovered) ±10%	HW (As Recovered) ±20%	JW & KW (As Recovered) ±20%
05	0.520 (13.2)	0.240 (6.1)	0.260 (6.6)	0.130 (3.3)	0.880 (22.4)	0.760 (19.3)	0.940 (23.9)	0.610 (15.5)	0.060 (1.5)	0.040 (1.0)
06	1.060 (26.9)	0.490 (12.4)	0.520 (13.2)	0.240 (6.1)	1.500 (38.1)	1.700 (43.2)	2.100 (53.3)	1.300 (33.0)	0.100 (2.5)	0.060 (1.5)
07	1.520 (38.6)	0.710 (18.0)	1.060 (26.9)	0.490 (12.4)	2.580 (65.5)	3.100 (78.7)	3.100 (78.7)	2.200 (55.9)	0.120 (3.0)	0.100 (2.5)
08	2.190 (55.6)	1.020 (25.9)	1.060 (26.9)	0.500 (12.7)	3.350 (85.1)	3.700 (94.0)	4.400 (111.8)	2.800 (71.1)	0.180 (4.6)	0.100 (2.5)

B

TABLE II: Shrink Boot Materials

Material Code	Compound	Material Description	Color Code
A	2071	Flexible Polyolefin	WHITE
B	2040	General Purpose Polyolefin	RED
G	2010	Zero Halogen Polyolefin	GREEN
H	2025	High Performance Elastomer	BLUE

TABLE III: Adhesive Description

Symbol	Adhesive Description
C	Zero Halogen / Hot Melt

APPLICATION NOTES

1. See bag identification for matching boot number, matching dash number on boot. See part number development for full description.
2. Encircled material letter designator located on O.D. approximately mid length along the "K" end. See part number development for full description.
3. Metric dimensions (mm) are in parentheses.

Dimensions in inches (millimeters) and are subject to change without notice.

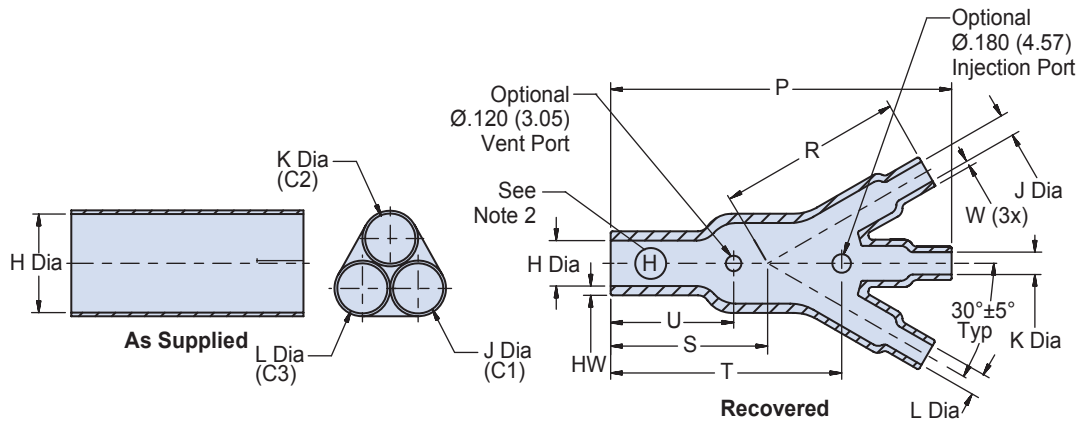
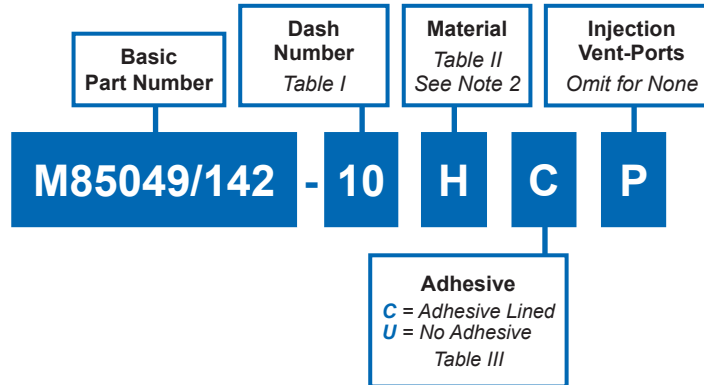

Dimensions in inches (millimeters) and are subject to change without notice.

AS85049/142 1:3 Transition Wide Body Heat Shrink Boot



AS85049

B

TABLE I: Dash Number and Dimensions (Continued Below)

Dash No.	H Dia Min (As Supplied)	H Dia Max (As Recovered)	J, K, L Dia Min (As Supplied)	J, K, L Dia Max (As Recovered)	P (As Recovered) ±10%	R (As Recovered) Ref
09	0.520 (13.2)	0.260 (6.6)	0.260 (6.6)	0.140 (3.6)	1.820 (46.2)	1.000 (25.4)
10	1.060 (26.9)	0.530 (13.5)	0.520 (13.2)	0.270 (6.9)	3.670 (93.2)	1.980 (50.3)
11	1.520 (38.6)	0.750 (19.1)	0.760 (19.3)	0.380 (9.7)	5.320 (135.1)	2.900 (73.7)
12	2.190 (55.6)	1.000 (25.4)	1.060 (26.9)	0.490 (12.4)	7.560 (192.0)	4.060 (103.1)
13	3.600 (91.4)	2.150 (54.6)	1.800 (45.7)	1.080 (27.4)	15.37 (390.4)	8.310 (211.1)

TABLE I: Dash Number and Dimensions (Continued from Above)

Dash No.	S (As Recovered) Ref	U (As Recovered) ±10%	T (As Recovered) ±10%	HW (As Recovered) ±20%	W (As Recovered) ±20%
09	0.820 (20.8)	0.620 (15.7)	1.200 (30.5)	0.060 (1.5)	0.040 (1.0)
10	1.690 (42.9)	1.300 (33.0)	2.250 (57.2)	0.100 (2.5)	0.060 (1.5)
11	2.420 (61.5)	1.800 (45.7)	3.500 (88.9)	0.120 (3.0)	0.070 (1.8)
12	3.500 (88.9)	2.800 (71.1)	4.800 (121.9)	0.180 (4.6)	0.120 (3.0)
13	7.060 (179.3)	5.00 (127.0)	10.00 (254.0)	0.280 (7.1)	0.180 (4.6)

TABLE II: Shrink Boot Materials

Material Code	Compound	Material Description	Color Code
A	2071	Flexible Polyolefin	WHITE
B	2040	General Purpose Polyolefin	RED
G	2010	Zero Halogen Polyolefin	GREEN
H	2025	High Performance Elastomer	BLUE

TABLE III: Adhesive Description

Symbol	Adhesive Description
C	Zero Halogen / Hot Melt

APPLICATION NOTES

1. See bag identification for matching boot number, matching dash number on boot. See part number development for full description.
2. Encircled material letter designator located on O.D. approximately mid length along the "H" end. See part number development for full description.
3. Metric dimensions (mm) are in parentheses.

Dimensions in inches (millimeters) and are subject to change without notice.

WHY GLENAIR?

ONE GOOD REASON TO SOURCE YOUR BACKSHELLS FROM GLENAIR



*Outstanding
Customer Service!*

OUTSTANDING CUSTOMER SERVICE

**Sales, service, and support professionals standing by...
when and where you need them**



MIL-DTL-38999 Qualified Connector Accessories



MIL-DTL-38999

Industry Specification Number	Part Identification Number	Military Part Number Superseded	Glenair Commercial Part Number	Description	Glenair Connector Designator/Interface	Page No.
MIL-DTL-38999 MIL-DTL-38999	MS27501 MS27502	MS20048 MS20047	660-012 660-013	Protective Plug Cover Protective Receptacle Cover	MIL-DTL-38999 Series I	C-2
MIL-DTL-38999	MS27510 MS27511	MS27352 MS27353	660-014 660-015	Protective Plug Cover Protective Receptacle Cover	MIL-DTL-38999 Series II	C-3
MIL-DTL-38999/22	D38999/22	---	650HS010	Dummy Storage Receptacle, Threaded Coupling	MIL-DTL-38999, Series III	C-4
MIL-DTL-38999/28	D38999/28	---	Consult Factory	Jam Nut with Safety Wire Holes	MIL-DTL-38999 Series III & IV; EN3645	C-5
MIL-DTL-38999/32 MIL-DTL-38999/33	D38999/32 D38999/33	---	660-023 660-024	Composite or Metal Threaded Plug Cover Composite or Metal Threaded Receptacle Cover	MIL-DTL-38999, Series III	C-6
MIL-DTL-38999/50	D38999/50	---	650HS007	Dummy Storage Receptacle, Bayonet Coupling	MIL-DTL-38999, Series IV	C-7

C

Dimensions in inches (millimeters) and are subject to change without notice.

© 2013 Glenair, Inc.

U.S. CAGE Code 06324

Printed in U.S.A.

GLENAIR, INC. • 1211 AIR WAY • GLENDALE, CA 91201-2497 • 818-247-6000 • FAX 818-500-9912
www.glenair.com C-1 E-Mail: sales@glenair.com



MS27501 and MS27502 Protective Plug and Receptacle Covers

MATING CONNECTOR

MIL-DTL-38999, Series I

Basic Part Number

MS27501 = Plug Cover
MS27502 = Receptacle Cover

Shell Size

19

Attachment Option

A = No Attachment
C = Chain
N = Chain with Ring (MS27502 Only)

MS27501

B

C

L

Finish

A = Gold Iridite over Cadmium over Nickel
B = 500 Hour Cadmium Olive Drab
C = Anodize
F = Electroless Nickel
T = Nickel Fluorocarbon Polymer
Z = Zinc Nickel

Length (Inches)

L = 5.0 (127.0)
M = 6.0 (152.4) MS27501 Only
N = 7.0 (177.8) MS27501 Only
(Omit for Standard)

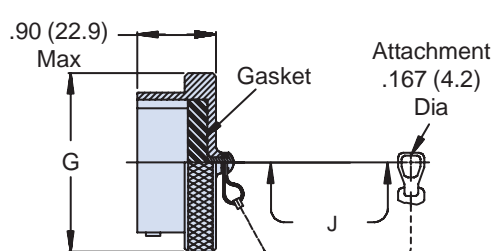

MS27501 Plug Cover

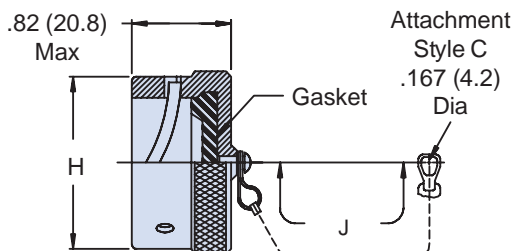

MS27502 Receptacle Cover

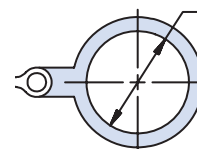

MS27502
Attachment
Type N

TABLE I: Shell Size, Attachment and Dimensions

Shell Size	G Dia Max	H Max	J Attachment Length (Inches)	K Dia Min
9	.820 (20.8)	.820 (20.8)	3.000 (76.2)	.700 (17.8)
11	.940 (23.9)	.940 (23.9)	3.000 (76.2)	.840 (21.3)
13	1.070 (27.2)	1.100 (27.9)	3.500 (88.9)	1.010 (25.7)
15	1.190 (30.2)	1.220 (31.0)	3.500 (88.9)	1.140 (29.0)
17	1.320 (33.5)	1.340 (34.0)	3.500 (88.9)	1.260 (32.0)
19	1.440 (36.6)	1.460 (37.1)	3.500 (88.9)	1.390 (35.3)
21	1.570 (39.9)	1.580 (40.1)	4.000 (101.6)	1.510 (38.4)
23	1.690 (42.9)	1.700 (43.2)	4.000 (101.6)	1.640 (41.7)
25	1.820 (46.2)	1.830 (46.5)	4.000 (101.6)	1.760 (44.7)

APPLICATION NOTES

1. Assembly identified with manufacturer's name and part number, space permitting.
2. For complete dimensions, see the applicable Military Specification.
3. Metric dimensions (mm) are in parentheses.

Dimensions in inches (millimeters) and are subject to change without notice.

MS27510 and MS27511 Protective Plug and Receptacle Covers



MIL-DTL-38999

MATING CONNECTOR
MIL-DTL-38999, Series II

Basic Part Number
MS27510 = Plug Cover
MS27511 = Receptacle Cover

Attachment Option
A = No Attachment
C = Chain
N = Chain with Ring (MS27511 Only)
R = Rope (MS27511 Only)

MS27511 B 19 C L

Finish
A = Gold Iridite over Cadmium over Nickel
B = 500 Hour Cadmium Olive Drab
C = Anodize
F = Electroless Nickel

Length (Inches)
L = 5.0 (127.0)
M = 6.0 (152.4) MS27510 Only
N = 7.0 (177.8) MS27510 Only
(Omit for Standard Length. Not Applicable to Style R—MS27511 Only)

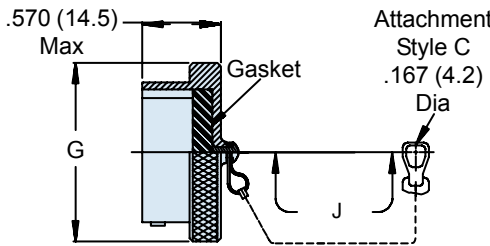
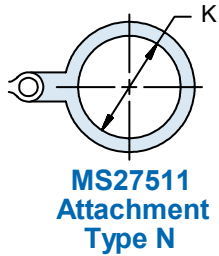

MS27510 Plug Cover

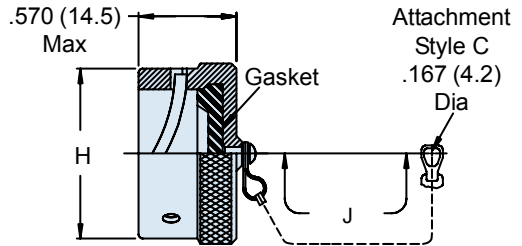

MS27511 Receptacle Cover

TABLE I: Shell Size, Attachment and Dimensions

Shell Size	G Dia Max	H Dia Max	J Std. Chain or Rope Length	K Dia Min
8	.720 (18.3)	.630 (16.0)	3.000 (76.2)	.890 (22.6)
10	.850 (21.6)	.761 (19.3)	3.000 (76.2)	1.010 (25.7)
12	1.000 (25.4)	.936 (23.8)	3.500 (88.9)	1.140 (29.0)
14	1.130 (28.7)	1.074 (27.3)	3.500 (88.9)	1.260 (32.0)
16	1.250 (31.8)	1.172 (29.8)	3.500 (88.9)	1.390 (35.3)
18	1.380 (35.1)	1.304 (33.1)	3.500 (88.9)	1.510 (38.4)
20	1.500 (38.1)	1.435 (36.4)	4.000 (101.6)	1.640 (41.7)
22	1.630 (41.4)	1.560 (39.6)	4.000 (101.6)	1.760 (44.7)
24	1.750 (44.5)	1.688 (42.9)	4.000 (101.6)	1.890 (48.0)

APPLICATION NOTES

1. Assembly identified with manufacturer's name and part number, space permitting.
2. For complete dimensions, see the applicable Military Specification.
3. Metric dimensions (mm) are in parentheses.

Dimensions in inches (millimeters) and are subject to change without notice.

D38999/22 Dummy Storage Receptacle Threaded Coupling

MATING CONNECTOR

MIL-DTL-38999 Series III

Shell
Size Code

D38999/22 **B** **W**

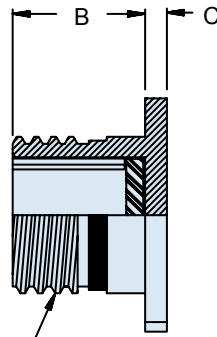
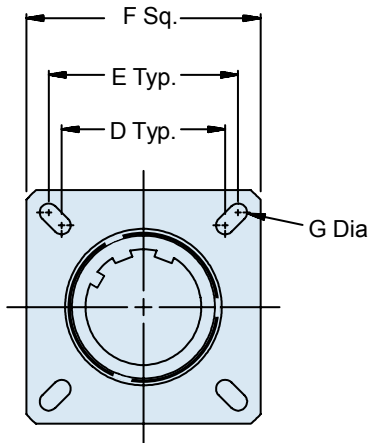
 Basic
Part No.

A Thread

Class per Spec

C = Aluminum Anodize
F = Aluminum, Electroless Nickel
H = Stainless Steel, Passivated (Space Grade)
J = Composite, Cadmium Plated, Olive Drab
K = Corrosion-Resistant Steel Passivate
M = Composite, Electroless Nickel Plated
N = Stainless Steel, Electrodeposited Nickel
Y = Stainless Steel, Passivated

TABLE I: Shell Size Code and Dimensions

Shell Size Code	Shell Size Ref.	A Thread	B -0.0		C		D	
			Max		+0.012	(0.3)		
A (See Note 4)	9	.625-.1P-3LTS	.820	(20.83)	.098	(2.5)	.594	(15.09)
AA (See Note 5)	9	.625-.1P-3LTS	.820	(20.83)	.098	(2.5)	.594	(15.09)
B	11	.750-.1P-3LTS	.820	(20.83)	.098	(2.5)	.719	(18.26)
C	13	.875-.1P-3LTS	.820	(20.83)	.098	(2.5)	.812	(20.62)
D	15	1.000-.1P-3LTS	.820	(20.83)	.098	(2.5)	.906	(23.01)
E	17	1.187-.1P-3LTS	.820	(20.83)	.098	(2.5)	.969	(24.61)
F	19	1.250-.1P-3LTS	.820	(20.83)	.098	(2.5)	1.062	(26.97)
G	21	1.375-.1P-3LTS	.790	(20.07)	.126	(3.2)	1.156	(29.36)
H	23	1.500-.1P-3LTS	.790	(20.07)	.126	(3.2)	1.250	(31.75)
J	25	1.625-.1P-3LTS	.790	(20.07)	.126	(3.2)	1.375	(34.93)

TABLE I: Shell Size Code and Dimensions

Shell Size Code	Shell Size Ref.	E	F -0.0		Ø G	
			+0.012	(0.3)	+0.008	(0.2)
A	9	.719 (18.26)	.937 (23.8)	.128 (3.25)		
B	11	.812 (20.62)	1.031 (26.2)	.128 (3.25)		
C	13	.906 (23.01)	1.126 (28.6)	.128 (3.25)		
D	15	.969 (24.61)	1.220 (31.0)	.128 (3.25)		
E	17	1.062 (26.97)	1.311 (33.3)	.128 (3.25)		
F	19	1.156 (29.36)	1.437 (36.5)	.128 (3.25)		
G	21	1.250 (31.75)	1.563 (39.7)	.128 (3.25)		
H	23	1.375 (34.93)	1.689 (42.9)	.154 (3.91)		
J	25	1.500 (38.10)	1.811 (46.0)	.154 (3.91)		

APPLICATION NOTES

1. Assembly to be identified with manufacturer's name and part number, space permitting.
2. For complete dimensions, see the applicable Military Specification.
3. Metric dimensions (mm) are in parentheses.
4. Shell size code "A" is for polarization C, E and N only.
5. Shell size code "AA" is for polarization A, B and D only.

Dimensions in inches (millimeters) and are subject to change without notice.

D38999/28 Jam Nut



MIL-DTL-38999

CONNECTOR DESIGNATOR:

H MIL-DTL-38999
Series III and IV, EN3645

Material and Finish

C = Aluminum Anodize
F = Aluminum, Electroless Nickel
K = Corrosion-Resistant Steel Passivate
W = Aluminum, Cadmium Olive Drab over Electroless Nickel

Basic
Part Number

D38999/28 - 11 A

Dash No.

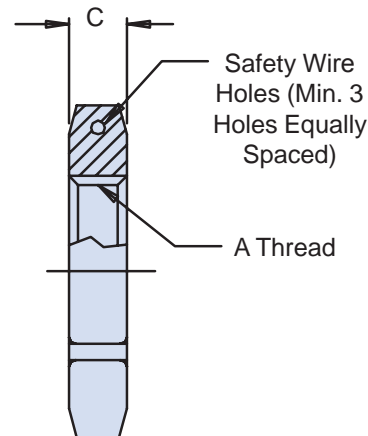
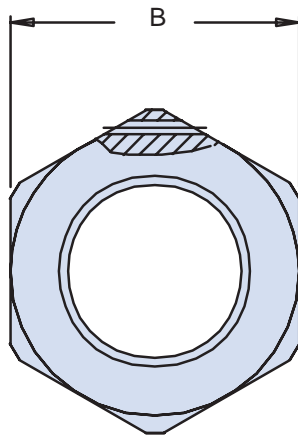

TABLE I: Reference for Connector Shell Size

Dash No.	Shell Size		A Thread Class 2B	B Hex Max		C	
	Series III	Series IV				±.018 -.000	(.45) (.00)
1	9	--	M17 X 1 - 6H*	.945	(24.00)	.125	(3.17)
2	11	--	M20 X 1 - 6H*	1.063	(27.00)	.125	(3.17)
3	13	11	M25 X 1 - 6H	1.260	(32.00)	.125	(3.17)
4	15	13	M28 X 1 - 6H	1.417	(36.00)	.125	(3.17)
5	--	15	M31 X 1 - 6H	1.614	(41.00)	.125	(3.17)
6	17	--	M32 X 1 - 6H	1.457	(37.00)	.125	(3.17)
7	--	17	M34 X 1 - 6H	1.614	(41.00)	.125	(3.17)
8	19	--	M35 X 1 - 6H	1.614	(41.00)	.125	(3.17)
9	21	19	M38 X 1 - 6H	1.811	(46.00)	.125	(3.17)
10	23	21	M41 X 1 - 6H	1.969	(50.00)	.125	(3.17)
11	25	23	M44 X 1 - 6H	2.017	(51.23)	.125	(3.17)
12	--	25	M47 X 1 - 6H	2.165	(55.00)	.125	(3.17)

*Modified Minor Diameter

APPLICATION NOTES

1. Assembly identified with manufacturer's name and part number, space permitting.
2. For complete dimensions, see the applicable Military Specification.
3. Metric dimensions (mm) are in parentheses.

Dimensions in inches (millimeters) and are subject to change without notice.



D38999/32 and D38999/33 Composite or Metal Protective Covers Plug and Receptacle • MIL-DTL-38999 Series III Threaded

MATING CONNECTOR

MIL-DTL-38999, Series III Threaded

Basic Part Number

D38999/32 = Plug Cover
D38999/33 = Receptacle Cover

Shell Size
Designator

Attachment Style
R or N

D38999/32

W

15

N

APPLICATION NOTES

1. Assembly identified with manufacturer's name and part number, space permitting.
2. For complete dimensions, see the applicable Military Specification.
3. Metric dimensions (mm) are in parentheses.

Material and Finish

C = Aluminum Anodize
F = Aluminum, Electroless Nickel
H = Stainless Steel, Passivated (Space Grade)
J = Composite, Cadmium Plated, Olive Drab
K = Corrosion-Resistant Steel Passivate
M = Composite, Electroless Nickel Plated
W = Aluminum, 500 Hour Cadmium Olive Drab

D38999/32 PLUG COVER

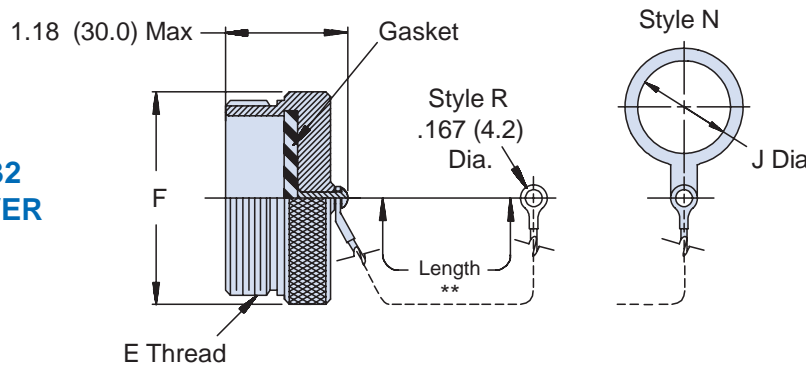

** Rope Length
5.000 (127.0)
+.50 (+13.0)
-.25 (-7.0)

D38999/33 RECEPTACLE COVER

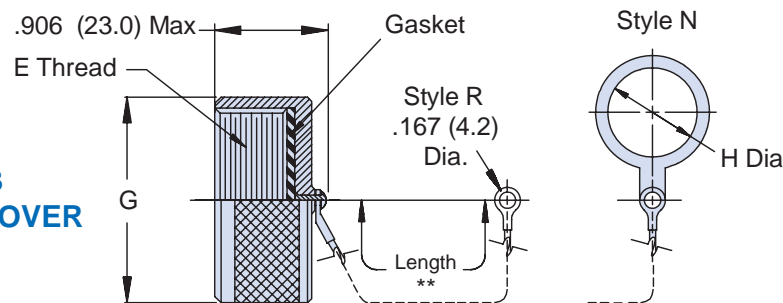

TABLE I: Shell Size, Thread and Dimensions

Shell Size	E Thread	F Max	G Max	H Min	J Min
9	.6250-0.1P-0.3L-TS	.906 (23.0)	.906 (23.0)	.694 (17.6)	.512 (13.0)
11	.7500-0.1P-0.3L-TS	1.024 (26.0)	1.102 (28.0)	.865 (22.0)	.709 (18.0)
13	.8750-0.1P-0.3L-TS	1.220 (31.0)	1.220 (31.0)	.989 (25.1)	.787 (20.0)
15	1.0000-0.1P-0.3L-TS	1.300 (33.0)	1.260 (32.0)	1.178 (29.9)	.906 (23.0)
17	1.1875-0.1P-0.3L-TS	1.457 (37.0)	1.457 (37.0)	1.260 (32.0)	1.024 (26.0)
19	1.2500-0.1P-0.3L-TS	1.575 (40.0)	1.535 (39.0)	1.428 (36.3)	1.142 (29.0)
21	1.3750-0.1P-0.3L-TS	1.732 (44.0)	1.654 (42.0)	1.506 (38.3)	1.260 (32.0)
23	1.5000-0.1P-0.3L-TS	1.811 (46.0)	1.772 (45.0)	1.678 (42.6)	1.339 (34.0)
25	1.6250-0.1P-0.3L-TS	1.969 (50.0)	1.929 (49.0)	1.750 (44.5)	1.535 (39.0)

Dimensions in inches (millimeters) and are subject to change without notice.

D38999/50 Dummy Stowage Receptacle Bayonet Coupling



MIL-DTL-38999

MATING CONNECTOR
MIL-DTL-38999 Series IV

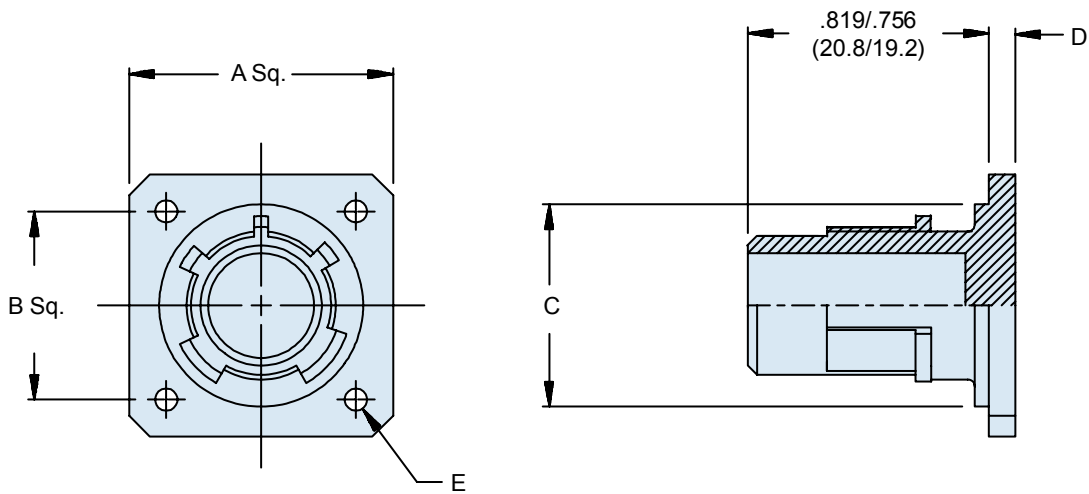
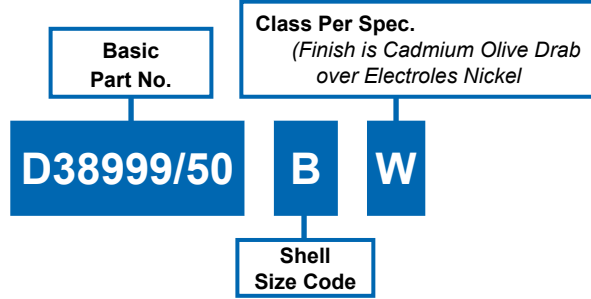

TABLE I: Dash Number, Cable Entry and Backshell Dimensions

Shell Size Code	Shell Size Ref.	A		B		C		D		Ø E	
		±.043	(±1.10)	BSC		+ 0	(0.00)	±.010	(±0.25)	±.008	(±0.2)
						-.015	(-0.39)				
B	11	1.030	(26.15)	.812	(20.62)	.793	(20.15)	.093	(2.35)	.130	(3.3)
C	13	1.124	(28.55)	.906	(23.02)	.919	(23.35)	.093	(2.35)	.130	(3.3)
D	15	1.219	(30.95)	.969	(24.62)	1.044	(26.52)	.093	(2.35)	.130	(3.3)
E	17	1.313	(33.35)	1.062	(26.98)	1.170	(29.72)	.093	(2.35)	.130	(3.3)
F	19	1.439	(36.55)	1.156	(29.36)	1.294	(32.87)	.093	(2.35)	.130	(3.3)
G	21	1.561	(39.65)	1.250	(31.76)	1.419	(36.05)	.124	(3.15)	.130	(3.3)
H	23	1.687	(42.85)	1.375	(34.92)	1.544	(39.22)	.124	(3.15)	.150	(3.8)
J	25	1.813	(46.05)	1.500	(38.10)	1.669	(42.40)	.124	(3.15)	.150	(3.8)

APPLICATION NOTES

1. Assembly to be identified with manufacturer's name and part number, space permitting.
2. For complete dimensions, see the applicable Military Specification.
3. Metric dimensions (mm) are in parentheses.

Dimensions in inches (millimeters) and are subject to change without notice.

WHY GLENAIR?

ANOTHER GOOD REASON

**TO SOURCE YOUR BACKSHELLS
FROM GLENAIR**



*Paul Winkler
Glenair Northern California
Sales Group*

NATIONWIDE TECH SUPPORT

**Technical support and application engineering is offered
nationwide by over 100 Glenair field representatives**



MIL-DTL-28840

Qualified Backshells and Connector Accessories



MIL-DTL-28840

Industry Specification Number	Part Identification Number	Military Part Number Superseded	Glenair Commercial Part Number	Description	Glenair Connector Designator/Interface	Page No.
MIL-DTL-28840/1	M28840/1	--	620GS051	Straight Non-Self-Locking Strain Relief	"G" MIL-DTL-28840	D-2
MIL-DTL-28840/2	M28840/2	--	620GA051	90° Non-Self-Locking Strain Relief	"G" MIL-DTL-28840	D-3
MIL-DTL-28840/3	M28840/3	--	620GB051	45° Non-Self-Locking Strain Relief	"G" MIL-DTL-28840	D-4
MIL-DTL-28840/4	M28840/4	--	--	Metal-Core Conduit	"G" MIL-DTL-28840	D-5
MIL-DTL-28840/5	M28840/5	--	--	Straight Backshell for Metal-Core Conduit	"G" MIL-DTL-28840	D-6
MIL-DTL-28840/6	M28840/6 A M28840/6 B	--	390AB001 370 Series	Strt. EMI/RFI Environmental Backshell, Style A Straight Environmental Backshell, Style B	"G" MIL-DTL-28840	D-7 D-8
MIL-DTL-28840/7	M28840/7	--	650GS001	Dummy Storage Receptacle, Threaded Coupling	"G" MIL-DTL-28840	D-9
MIL-DTL-28840/8	M28840/8- M28840/8 A	--	390-061	90° Environmental Backshell, Style A 90° EMI/RFI Environmental Backshell, Style B	"G" MIL-DTL-28840	D-10 D-11
MIL-DTL-28840/9	M28840/9 B M28840/9 A	--	390-061	45° Environmental Backshell, Style A 45° EMI/RFI Environmental Backshell	"G" MIL-DTL-28840	D-12 D-13
MIL-DTL-28840/13 MIL-DTL-28840/15	M28840/13 M28840/15	--	660-010 660-011	Protective Threaded Receptacle Cover Protective Threaded Plug Cover	MIL-DTL-28840	D-14
MIL-DTL-28840/22	M28840/22	--	--	Metal-Core Conduit Bushing	"G" MIL-DTL-28840	D-15
MIL-DTL-28840/23	M28840/23	--	Consult Factory	E Nut, Non-Self-Locking	"G" MIL-DTL-28840	D-16
MIL-DTL-28840/24	M28840/24	--	Consult Factory	Gasket	"G" MIL-DTL-28840	D-17

D

Dimensions in inches (millimeters) and are subject to change without notice.

© 2013 Glenair, Inc.

U.S. CAGE Code 06324

Printed in U.S.A.



MIL-DTL-28840/1 Straight Non-Self-Locking Strain Relief

CONNECTOR DESIGNATOR:

G MIL-DTL-28840

Basic
Part Number

Designator

M28840/1

J

W

Material and Finish

D = Corrosion Resistant Steel,
Cadmium Plate, Black

W = Aluminum, Cadmium Olive Drab

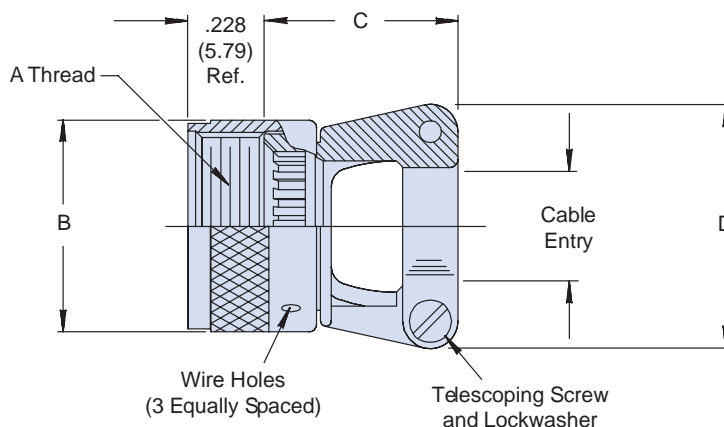

TABLE I: Shell Size, Cable Entry and Backshell Dimensions

Designator	Shell Size Ref.	A Thread Class 2B	C Max	E Max	F Max	Cable Entry					
						Closed		Open			
A	11	.750 - 20 UNEF	1.028 (26.1)	1.091 (27.7)	.903 (22.9)	.177 (4.5)	.286 (7.3)	.177 (4.5)	.286 (7.3)	.177 (4.5)	.286 (7.3)
B	13	.875 - 20 UNEF	1.141 (29.0)	1.091 (27.7)	.977 (24.8)	.177 (4.5)	.286 (7.3)	.177 (4.5)	.286 (7.3)	.177 (4.5)	.286 (7.3)
C	15	1.000 - 20 UNEF	1.263 (32.1)	1.091 (27.7)	1.151 (29.2)	.250 (6.4)	.416 (10.6)	.250 (6.4)	.416 (10.6)	.250 (6.4)	.416 (10.6)
D	17	1.125 - 18 UNEF	1.387 (35.2)	1.206 (30.6)	1.281 (32.5)	.291 (7.4)	.476 (12.1)	.291 (7.4)	.476 (12.1)	.291 (7.4)	.476 (12.1)
E	19	1.250 - 18 UNEF	1.513 (38.4)	1.320 (33.5)	1.406 (35.7)	.348 (8.8)	.626 (15.9)	.348 (8.8)	.626 (15.9)	.348 (8.8)	.626 (15.9)
F	23	1.438 - 18 UNEF	1.703 (43.3)	1.445 (36.7)	1.576 (40.0)	.429 (10.9)	.831 (21.1)	.429 (10.9)	.831 (21.1)	.429 (10.9)	.831 (21.1)
G	25	1.562 - 18 UNEF	1.825 (46.4)	1.570 (39.9)	1.666 (42.3)	.523 (13.3)	.956 (24.3)	.523 (13.3)	.956 (24.3)	.523 (13.3)	.956 (24.3)
H	29	1.875 - 16 UN	2.143 (54.4)	1.721 (43.7)	2.046 (52.0)	.643 (16.3)	1.081 (27.5)	.643 (16.3)	1.081 (27.5)	.643 (16.3)	1.081 (27.5)
J	33	2.062 - 16 UNS	2.329 (59.2)	1.908 (48.5)	2.209 (56.1)	.704 (17.9)	1.187 (30.1)	.704 (17.9)	1.187 (30.1)	.704 (17.9)	1.187 (30.1)

APPLICATION NOTES

1. Assembly to be identified with manufacturer's name and part number, space permitting.
2. Cable Entry is defined as the accommodation entry for the wire bundle or cable. Dimensions are not intended for inspection criteria.
3. For complete dimensions, see the applicable Military Specification.
4. Metric dimensions (mm) are in parentheses.

Dimensions in inches (millimeters) and are subject to change without notice.

MIL-DTL-28840/2 90° Non-Self-Locking Strain Relief



MIL-DTL-28840

CONNECTOR DESIGNATOR:	
G	MIL-DTL-28840

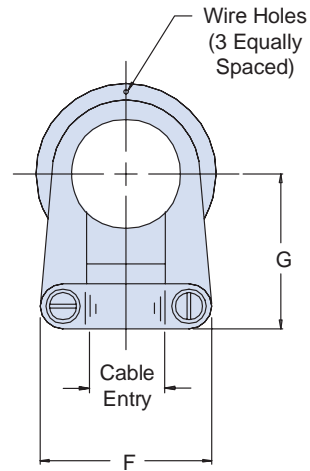
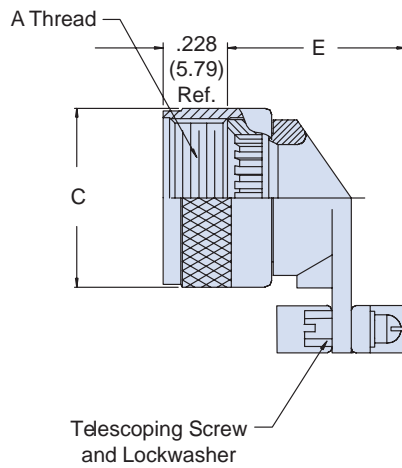
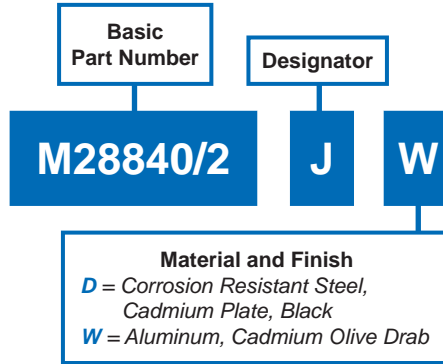

TABLE I: Shell Size, Cable Entry and Backshell Dimensions

Designator	Shell Size Ref.	A Thread Class 2B	C Max	E Max	F Max	G Max	Cable Entry			
							Min	Max	Min	Max
A	11	.750 - 20 UNEF	1.028 (26.1)	1.071 (27.2)	.903 (22.9)	.929 (23.6)	.177 (4.5)	.286 (7.3)	.177 (4.5)	.286 (7.3)
B	13	.875 - 20 UNEF	1.141 (29.0)	1.071 (27.2)	.977 (24.8)	.929 (23.6)	.177 (4.5)	.286 (7.3)	.177 (4.5)	.286 (7.3)
C	15	1.000 - 20 UNEF	1.263 (32.1)	1.280 (32.5)	1.151 (29.2)	1.056 (26.8)	.250 (6.4)	.416 (10.6)	.250 (6.4)	.416 (10.6)
D	17	1.125 - 18 UNEF	1.387 (35.2)	1.392 (35.4)	1.281 (32.5)	1.233 (31.3)	.291 (7.4)	.476 (12.1)	.291 (7.4)	.476 (12.1)
E	19	1.250 - 18 UNEF	1.513 (38.4)	1.517 (38.5)	1.406 (35.7)	1.296 (32.9)	.348 (8.8)	.626 (15.9)	.348 (8.8)	.626 (15.9)
F	23	1.438 - 18 UNEF	1.703 (43.3)	1.642 (41.7)	1.576 (40.0)	1.358 (34.5)	.429 (10.9)	.831 (21.1)	.429 (10.9)	.831 (21.1)
G	25	1.562 - 18 UNEF	1.825 (46.4)	1.767 (44.9)	1.666 (42.3)	1.420 (36.1)	.523 (13.3)	.956 (24.3)	.523 (13.3)	.956 (24.3)
H	29	1.875 - 16 UN	2.143 (54.4)	1.905 (48.4)	2.046 (52.0)	1.634 (41.5)	.643 (16.3)	1.081 (27.5)	.643 (16.3)	1.081 (27.5)
J	33	2.062 - 16 UNS	2.329 (59.2)	1.968 (50.0)	2.209 (56.1)	1.859 (47.2)	.704 (17.9)	1.187 (30.1)	.704 (17.9)	1.187 (30.1)

APPLICATION NOTES

1. Assembly to be identified with manufacturer's name and part number, space permitting.
2. Cable Entry is defined as the accommodation entry for the wire bundle or cable. Dimensions are not intended for inspection criteria.
3. For complete dimensions, see the applicable Military Specification.
4. Metric dimensions (mm) are in parentheses.

Dimensions in inches (millimeters) and are subject to change without notice.



MIL-DTL-28840/3 45° Non-Self-Locking Strain Relief

CONNECTOR DESIGNATOR:

G MIL-DTL-28840

Basic
Part Number

Designator

M28840/3

J

W

Material and Finish

D = Corrosion Resistant Steel,
Cadmium Plate, Black
W = Aluminum, Cadmium Olive Drab

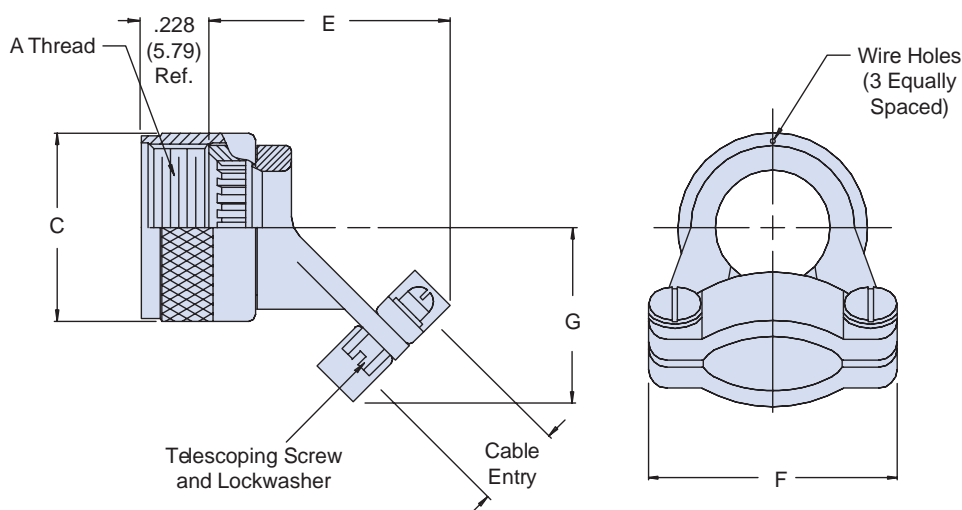

TABLE I: Shell Size, Cable Entry and Backshell Dimensions

Designator	Shell Size Ref.	A Thread Class 2B	C Max	E Max	F Max	G Max	Cable Entry			
							Min	Max	Min	Max
A	11	.750 - 20 UNEF	1.028 (26.1)	1.650 (41.9)	.903 (22.9)	.929 (23.6)	.177 (4.5)	.286 (7.3)	.177 (4.5)	.286 (7.3)
B	13	.875 - 20 UNEF	1.141 (29.0)	1.650 (41.9)	.977 (24.8)	.929 (23.6)	.177 (4.5)	.286 (7.3)	.177 (4.5)	.286 (7.3)
C	15	1.000 - 20 UNEF	1.263 (32.1)	1.765 (44.8)	1.151 (29.2)	1.056 (26.8)	.250 (6.4)	.416 (10.6)	.250 (6.4)	.416 (10.6)
D	17	1.125 - 18 UNEF	1.387 (35.2)	1.874 (47.6)	1.281 (32.5)	1.233 (31.3)	.291 (7.4)	.476 (12.1)	.291 (7.4)	.476 (12.1)
E	19	1.250 - 18 UNEF	1.513 (38.4)	1.918 (48.7)	1.406 (35.7)	1.296 (32.9)	.348 (8.8)	.626 (15.9)	.348 (8.8)	.626 (15.9)
F	23	1.438 - 18 UNEF	1.703 (43.3)	1.962 (49.8)	1.576 (40.0)	1.358 (34.5)	.429 (10.9)	.831 (21.1)	.429 (10.9)	.831 (21.1)
G	25	1.562 - 18 UNEF	1.825 (46.4)	2.006 (51.0)	1.666 (42.3)	1.420 (36.1)	.523 (13.3)	.956 (24.3)	.523 (13.3)	.956 (24.3)
H	29	1.875 - 16 UN	2.143 (54.4)	2.301 (58.4)	2.046 (52.0)	1.634 (41.5)	.643 (16.3)	1.081 (27.5)	.643 (16.3)	1.081 (27.5)
J	33	2.062 - 16 UNS	2.329 (59.2)	2.389 (60.7)	2.209 (56.1)	1.859 (47.2)	.704 (17.9)	1.187 (30.1)	.704 (17.9)	1.187 (30.1)

APPLICATION NOTES

1. Assembly to be identified with manufacturer's name and part number, space permitting.
2. Cable Entry is defined as the accommodation entry for the wire bundle or cable. Dimensions are not intended for inspection criteria.
3. For complete dimensions, see the applicable Military Specification.
4. Metric dimensions (mm) are in parentheses.

Dimensions in inches (millimeters) and are subject to change without notice.

M28840/4 Metal Core Conduit



MIL-DTL-28840

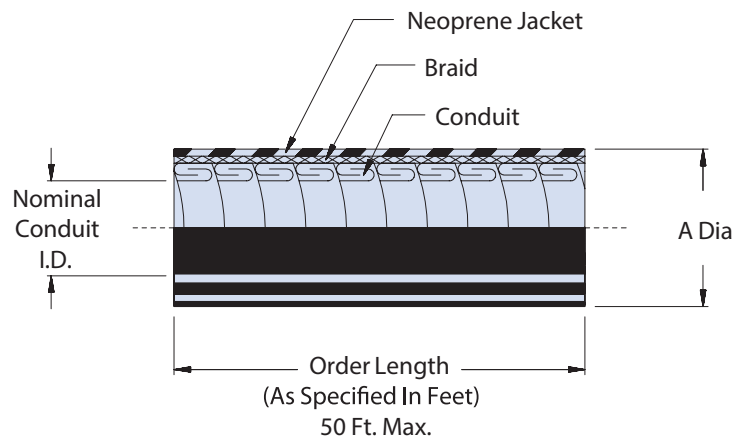
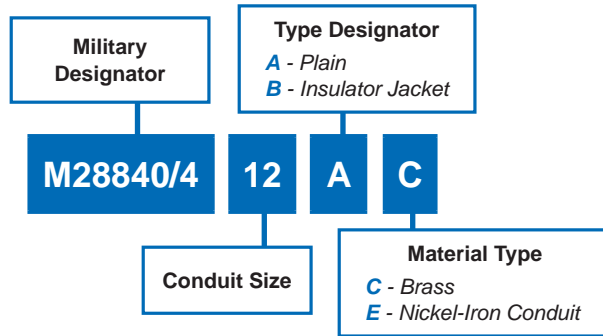

D

Size	Nominal Conduit Inside Diameter	A Diameter Over Shield ± .010 (0.25)	L	B Diameter Max Over Jacket
03	.375 (9.52)	.525 (13.34)	50 ft. Max.	.688 (17.47)
04	.500 (12.70)	.650 (16.51)		.812 (20.62)
05	.625 (15.87)	.765 (19.43)		.937 (23.79)
06	.750 (19.05)	.925 (23.50)		1.078 (27.38)
08	1.00 (25.40)	1.210 (30.73)		1.437 (36.49)
10	1.25 (31.75)	1.455 (36.96)		1.695 (43.05)
12	1.500 (38.10)	1.725 (43.82)		1.956 (49.68)
16	2.000 (50.80)	2.200 (55.88)		2.469 (62.71)

Dimensions in inches (millimeters) and are subject to change without notice.



M28840/5 Backshell for Metal Core Conduit

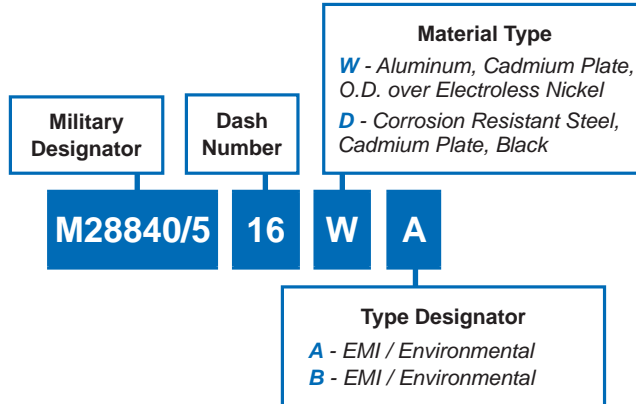

D

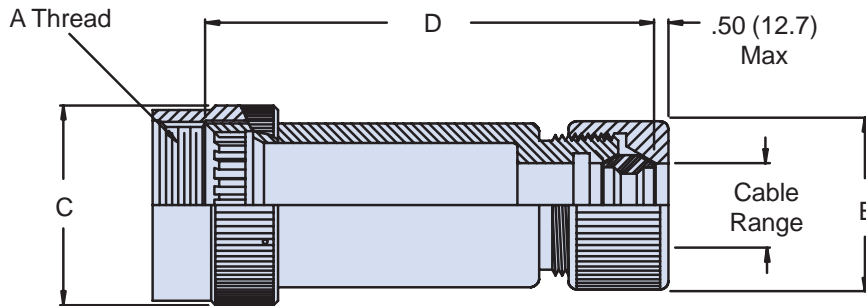

STYLE A - EMI/Non-Environmental
(Plain Conduit)

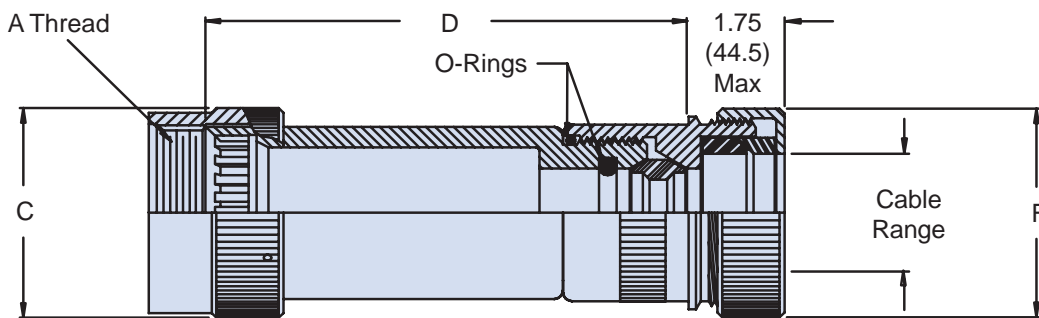

STYLE B - EMI/Environmental
(Jacket Conduit)

Dimensions in inches (millimeters) and are subject to change without notice.

MIL-DTL-28840/6 Style A Straight EMI/RFI Environmental Backshell



MIL-DTL-28840

CONNECTOR DESIGNATOR:	
G	MIL-DTL-28840

Material and Finish
D = Corrosion Resistant Steel, Cadmium Plate, Black
W = Aluminum, Cadmium Olive Drab

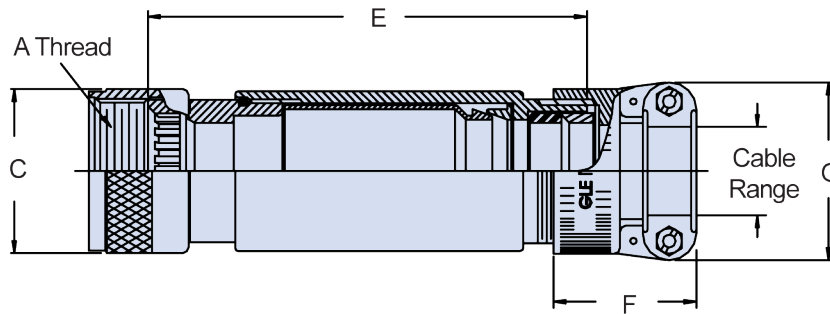
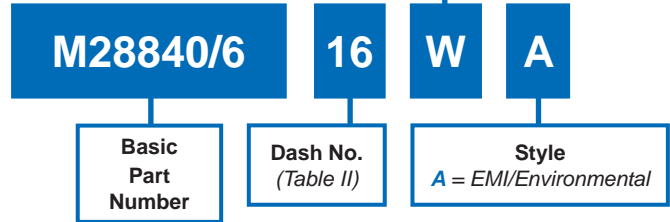

TABLE I: Shell Size and Dimensions

Shell Size	A Thread Class 2B	C Dia Max
11	.750 - 20 UNEF	1.028 (26.1)
13	.875 - 20 UNEF	1.141 (29.0)
15	1.000 - 20 UNEF	1.263 (32.1)
17	1.125 - 18 UNEF	1.387 (35.2)
19	1.250 - 18 UNEF	1.513 (38.4)
23	1.438 - 18 UNEF	1.703 (43.3)
25	1.562 - 18 UNEF	1.825 (46.4)
29	1.875 - 16 UN	2.143 (54.4)
33	2.062 - 16 UNS	2.329 (59.2)

APPLICATION NOTES

- For complete dimensions see the applicable Military Specification.
- Metric dimensions (mm) are in parentheses.
- Cable Range is defined as the accommodation range for the wire bundle or cable. Dimensions shown are not intended for inspection criteria.

TABLE II: Dash Number, Shell Size, Dimensions and Cable Range

Dash No.	Shell Size	E ± .120 (3.0)	F Ref Dim	G Ref Dim	Cable Range	
					Min	Max
01	11	3.62 (91.9)	1.281 (32.5)	.938 (23.8)	.188 (4.8)	.312 (7.9)
02	13	3.62 (91.9)	1.281 (32.5)	.938 (23.8)	.188 (4.8)	.312 (7.9)
03	13	3.62 (91.9)	1.281 (32.5)	1.125 (28.6)	.281 (7.1)	.438 (11.1)
04	15	3.62 (91.9)	1.281 (32.5)	.938 (23.8)	.188 (4.8)	.312 (7.9)
05	15	3.62 (91.9)	1.281 (32.5)	1.125 (28.6)	.281 (7.1)	.438 (11.1)
06	15	3.62 (91.9)	1.281 (32.5)	1.312 (33.3)	.344 (8.7)	.562 (14.3)
07	15	4.12 (104.6)	1.312 (33.3)	1.593 (40.5)	.438 (11.1)	.750 (19.1)
08	17	4.12 (104.6)	1.281 (32.5)	1.312 (33.3)	.375 (9.5)	.625 (15.9)
09	17	4.12 (104.6)	1.312 (33.3)	1.593 (40.5)	.438 (11.1)	.750 (19.1)
10	17	4.12 (104.6)	1.406 (35.7)	1.750 (44.5)	.625 (15.9)	.938 (23.8)
11	19	4.12 (104.6)	1.281 (32.5)	1.312 (33.3)	.375 (9.5)	.625 (15.9)
12	19	4.12 (104.6)	1.406 (35.7)	1.750 (44.5)	.625 (15.9)	.938 (23.8)
13	23	4.62 (117.3)	1.312 (33.3)	1.593 (40.5)	.438 (11.1)	.750 (19.1)
14	23	4.62 (117.3)	1.406 (35.7)	1.750 (44.5)	.625 (15.9)	.938 (23.8)
15	23	4.62 (117.3)	1.593 (40.5)	2.093 (53.2)	.812 (20.6)	1.188 (30.2)
16	25	4.62 (117.3)	1.406 (35.7)	1.750 (44.5)	.625 (15.9)	.938 (23.8)
17	25	5.12 (130.0)	1.593 (40.5)	2.093 (53.2)	.812 (20.6)	1.188 (30.2)
18	25	5.12 (130.0)	1.593 (40.5)	2.093 (53.2)	.875 (22.2)	1.250 (31.8)
19	25	5.12 (130.0)	1.625 (41.3)	2.343 (59.5)	1.000 (25.4)	1.380 (35.1)
20	29	5.12 (130.0)	1.593 (40.5)	2.093 (53.2)	.812 (20.6)	1.188 (30.2)
21	29	5.12 (130.0)	1.625 (41.3)	2.343 (59.5)	1.000 (25.4)	1.380 (35.1)
22	33	5.12 (130.0)	1.625 (41.3)	2.343 (59.5)	1.000 (25.4)	1.380 (35.1)
23	33	5.12 (130.0)	1.900 (48.3)	2.750 (69.9)	1.250 (31.8)	1.625 (41.3)
24	11	3.62 (91.9)	1.281 (32.5)	1.125 (28.6)	.281 (7.1)	.438 (11.1)
25	11	3.62 (91.9)	1.281 (32.5)	1.312 (33.3)	.344 (8.7)	.562 (14.3)
26	13	3.62 (91.9)	1.281 (32.5)	1.312 (33.3)	.344 (8.7)	.562 (14.3)
27	13	4.12 (104.6)	1.281 (32.5)	1.312 (33.3)	.375 (9.5)	.625 (15.9)
28	15	4.12 (104.6)	1.281 (32.5)	1.312 (33.3)	.375 (9.5)	.625 (15.9)

Dimensions in inches (millimeters) and are subject to change without notice.



MIL-DTL-28840/6 Style B Straight Environmental Backshell

CONNECTOR DESIGNATOR:

G MIL-DTL-28840

Basic
Part Number

M28840/6

Material and Finish

D = Corrosion Resistant Steel,
Cadmium Plate, Black
W = Aluminum, Cadmium Olive Drab

16

Dash Number
(Table II)

W

B

Style Designator
B = Environmental

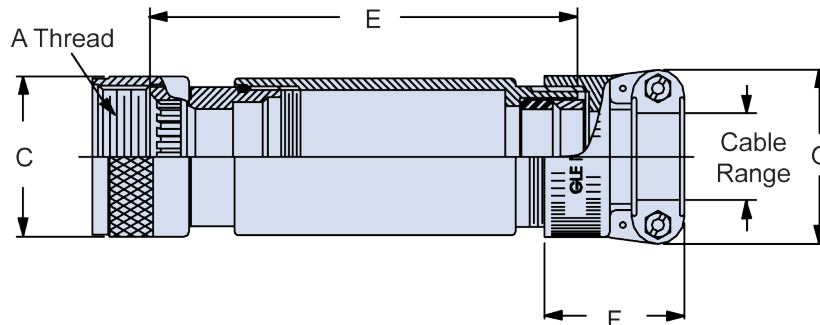

APPLICATION NOTES

- For complete dimensions see the applicable Military Specification.
- Metric dimensions (mm) are in parentheses.
- Cable Range is defined as the accommodation range for the wire bundle or cable. Dimensions shown are not intended for inspection criteria.

TABLE I: Shell Size

Shell Size	A Thread Class 2B	C Dia Max
11	.750 - 20 UNEF	1.030 (26.2)
13	.875 - 20 UNEF	1.140 (29.0)
15	1.000 - 20 UNEF	1.260 (32.0)
17	1.125 - 18 UNEF	1.390 (35.3)
19	1.250 - 18 UNEF	1.510 (38.4)
23	1.438 - 18 UNEF	1.700 (43.2)
25	1.563 - 18 UNEF	1.820 (46.2)
29	1.875 - 16 UN	2.140 (54.4)
33	2.063 - 16 UNS	2.330 (59.2)

TABLE II: Dash Number and Dimensions

Dash No.	Shell Size Ref.	E ± .12 (3.0)	F Ref. Dim	G Ref. Dim	Cable Range	
					Min	Max
01	11	3.620 (91.9)	1.281 (32.5)	.938 (23.8)	.188 (4.8)	.312 (7.9)
02	13	3.620 (91.9)	1.281 (32.5)	.938 (23.8)	.188 (4.8)	.312 (7.9)
03	13	3.620 (91.9)	1.281 (32.5)	1.125 (28.6)	.281 (7.1)	.438 (11.1)
04	15	3.620 (91.9)	1.281 (32.5)	.938 (23.8)	.188 (4.8)	.312 (7.9)
05	15	3.620 (91.9)	1.281 (32.5)	1.125 (28.6)	.281 (7.1)	.438 (11.1)
06	15	3.620 (91.9)	1.281 (32.5)	1.312 (33.3)	.344 (8.7)	.562 (14.3)
07	15	4.120 (104.6)	1.312 (33.3)	1.593 (40.5)	.438 (11.1)	.750 (19.1)
08	17	4.120 (104.6)	1.281 (32.5)	1.312 (33.3)	.375 (9.5)	.625 (15.9)
09	17	4.120 (104.6)	1.312 (33.3)	1.593 (40.5)	.438 (11.1)	.750 (19.1)
10	17	4.120 (104.6)	1.406 (35.7)	1.750 (44.5)	.625 (15.9)	.938 (23.8)
11	19	4.120 (104.6)	1.281 (32.5)	1.312 (33.3)	.375 (9.5)	.625 (15.9)
12	19	4.120 (104.6)	1.406 (35.7)	1.750 (44.5)	.625 (15.9)	.938 (23.8)
13	23	4.620 (117.3)	1.312 (33.3)	1.593 (40.5)	.438 (11.1)	.750 (19.1)
14	23	4.620 (117.3)	1.406 (35.7)	1.750 (44.5)	.625 (15.9)	.938 (23.8)
15	23	4.620 (117.3)	1.593 (40.5)	2.003 (50.9)	.812 (20.6)	1.188 (30.2)
16	25	4.620 (117.3)	1.406 (35.7)	1.750 (44.5)	.625 (15.9)	.938 (23.8)
17	25	5.120 (130.0)	1.593 (40.5)	2.093 (53.2)	.812 (20.6)	1.188 (30.2)
18	25	5.120 (130.0)	1.593 (40.5)	2.093 (53.2)	.875 (22.2)	1.250 (31.8)
19	25	5.120 (130.0)	1.625 (41.3)	2.343 (59.5)	1.000 (25.4)	1.380 (35.1)
20	29	5.120 (130.0)	1.593 (40.5)	2.093 (53.2)	.812 (20.6)	1.188 (30.2)
21	29	5.120 (130.0)	1.625 (41.3)	2.343 (59.5)	1.000 (25.4)	1.380 (35.1)
22	33	5.120 (130.0)	1.625 (41.3)	2.343 (59.5)	1.000 (25.4)	1.380 (35.1)
23	33	5.120 (130.0)	1.900 (48.3)	2.750 (69.9)	1.250 (31.8)	1.625 (41.3)
24	11	3.620 (91.9)	1.281 (32.5)	1.125 (28.6)	.281 (7.1)	.438 (11.1)
25	11	3.620 (91.9)	1.281 (32.5)	1.312 (33.3)	.344 (8.7)	.562 (14.3)
26	13	3.620 (91.9)	1.281 (32.5)	1.312 (33.3)	.344 (8.7)	.562 (14.3)
27	13	4.120 (104.6)	1.281 (32.5)	1.312 (33.3)	.375 (9.5)	.625 (15.9)
28	15	4.120 (104.6)	1.281 (32.5)	1.312 (33.3)	.375 (9.5)	.625 (15.9)

Dimensions in inches (millimeters) and are subject to change without notice.

M28840/7 Dummy Storage Receptacle Threaded Coupling



MIL-DTL-28840

MATING CONNECTOR
MIL-DTL-28840

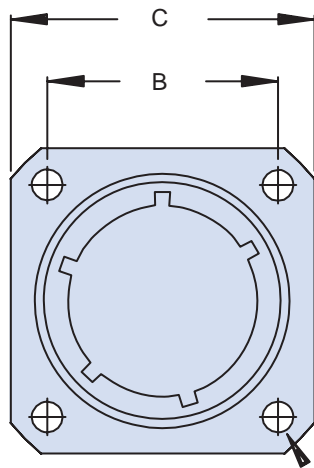
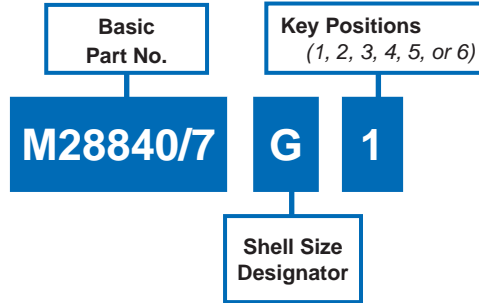

D Dia
4 Holes

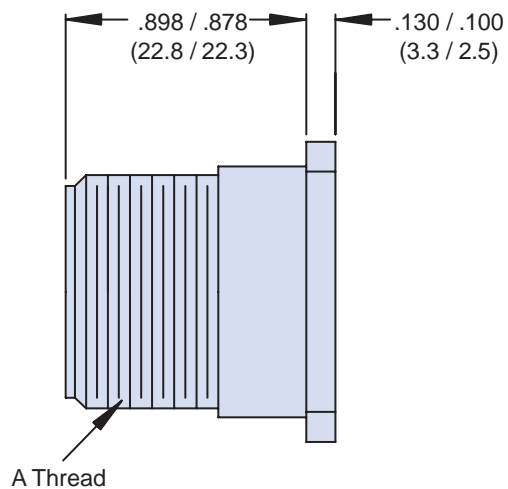

TABLE I: Dash Number, Cable Entry and Backshell Dimensions

Shell Size Designator	Shell Size Ref.	E Thread	B Dim	C Max	D Max
A	11	0.750-0.1P-0.2L-DS	.750 (19.1)	1.043 (26.5)	.130 (3.3)
B	13	0.875-0.1P-0.2L-DS	.843 (21.4)	1.158 (29.4)	.130 (3.3)
C	15	1.062-0.1P-0.2L-DS	.968 (24.6)	1.278 (32.5)	.130 (3.3)
D	17	1.125-0.1P-0.2L-DS	1.015 (25.8)	1.403 (35.6)	.130 (3.3)
E	19	1.312-0.1P-0.2L-DS	1.140 (29.0)	1.528 (38.8)	.130 (3.3)
F	23	1.500-0.1P-0.2L-DS	1.281 (32.5)	1.738 (44.1)	.130 (3.3)
G	25	1.625-0.1P-0.2L-DS	1.392 (35.4)	1.838 (46.7)	.157 (4.0)
H	29	1.812-0.1P-0.2L-DS	1.568 (39.8)	2.158 (54.8)	.157 (4.0)
J	33	2.000-0.1P-0.2L-DS	1.734 (44.0)	2.348 (59.6)	.183 (4.6)

APPLICATION NOTES

1. Assembly to be identified with manufacturer's name and part number, space permitting.
2. For complete dimensions, see the applicable Military Specification.
3. Material/Finish: Aluminum Alloy/Cadmium Olive Drab.
4. Metric dimensions (mm) are in parentheses.

Dimensions in inches (millimeters) and are subject to change without notice.





MIL-DTL-28840/8 Style A 90° EMI/RFI Environmental Backshell

CONNECTOR DESIGNATOR:

G MIL-DTL-28840

Material and Finish

D = Corrosion Resistant Steel, Cadmium Plate, Black
W = Aluminum, Cadmium Olive Drab

M28840/8

16

W

A

**Basic
Part
Number**

**Dash No.
(Table II)**

**Style
A = EMI/Environmental**

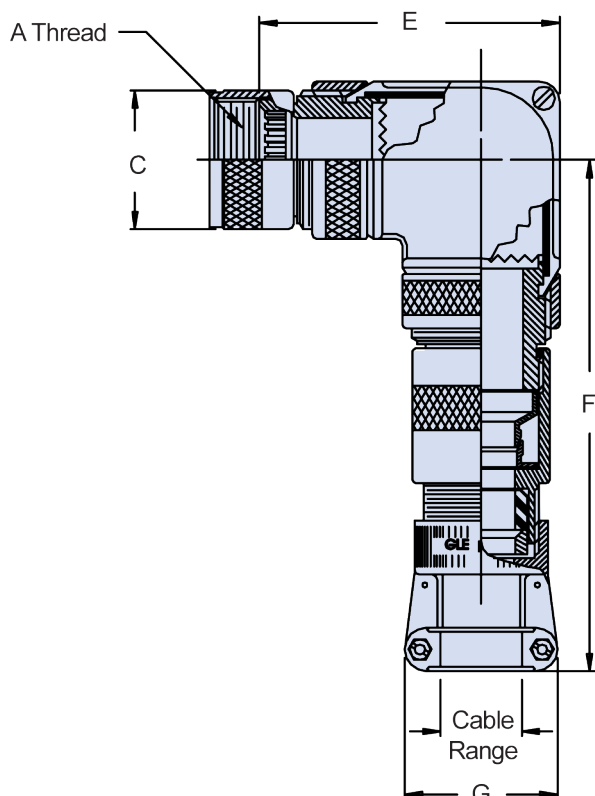

TABLE II: Dash Number, Shell Size, Dimensions and Cable Range

Dash No.	Shell Size	E Max Envelope	F Max	G Ref Dim	Cable Range	
					Min	Max
01	11	2.614 (66.4)	5.332 (135.4)	.938 (23.8)	.188 (4.8)	.312 (7.9)
02	13	2.614 (66.4)	5.332 (135.4)	.938 (23.8)	.188 (4.8)	.312 (7.9)
03	13	2.614 (66.4)	5.332 (135.4)	1.125 (28.6)	.281 (7.1)	.438 (11.1)
04	15	2.864 (72.7)	5.457 (138.6)	.938 (23.8)	.188 (4.8)	.312 (7.9)
05	15	2.864 (72.7)	5.457 (138.6)	1.125 (28.6)	.281 (7.1)	.438 (11.1)
06	15	2.864 (72.7)	5.457 (138.6)	1.312 (33.3)	.344 (8.7)	.562 (14.3)
07	15	3.114 (79.1)	5.682 (144.3)	1.593 (40.5)	.438 (11.1)	.750 (19.1)
08	17	3.114 (79.1)	5.682 (144.3)	1.312 (33.3)	.375 (9.5)	.625 (15.9)
09	17	3.114 (79.1)	5.713 (145.1)	1.593 (40.5)	.438 (11.1)	.750 (19.1)
10	17	3.114 (79.1)	5.807 (147.5)	1.750 (44.5)	.625 (15.9)	.938 (23.8)
11	19	3.114 (79.1)	5.682 (144.3)	1.312 (33.3)	.375 (9.5)	.625 (15.9)
12	19	3.364 (85.4)	5.832 (148.1)	1.750 (44.5)	.625 (15.9)	.938 (23.8)
13	23	3.364 (85.4)	5.738 (145.7)	1.593 (40.5)	.438 (11.1)	.750 (19.1)
14	23	3.364 (85.4)	5.832 (148.1)	1.750 (44.5)	.625 (15.9)	.938 (23.8)
15	23	3.364 (85.4)	6.019 (152.9)	2.093 (53.2)	.812 (20.6)	1.188 (30.2)
16	25	3.364 (85.4)	5.832 (148.1)	1.750 (44.5)	.625 (15.9)	.938 (23.8)
17	25	3.364 (85.4)	6.019 (152.9)	2.093 (53.2)	.812 (20.6)	1.188 (30.2)
18	25	3.614 (91.8)	6.144 (156.1)	2.093 (53.2)	.875 (22.2)	1.250 (31.8)
19	25	3.614 (91.8)	6.176 (156.9)	2.343 (59.5)	1.000 (25.4)	1.380 (35.1)
20	29	3.614 (91.8)	6.144 (156.1)	2.093 (53.2)	.812 (20.6)	1.188 (30.2)
21	29	3.614 (91.8)	6.176 (156.9)	2.343 (59.5)	1.000 (25.4)	1.380 (35.1)
22	33	4.114 (104.5)	6.426 (163.2)	2.343 (59.5)	1.000 (25.4)	1.380 (35.1)
23	33	4.114 (104.5)	6.701 (170.2)	2.750 (69.9)	1.250 (31.8)	1.625 (41.3)
24	11	2.614 (66.4)	5.332 (135.4)	1.125 (28.6)	.281 (7.1)	.438 (11.1)
25	11	2.864 (72.7)	5.457 (138.6)	1.312 (33.3)	.344 (8.7)	.562 (14.3)
26	13	2.864 (72.7)	5.457 (138.6)	1.312 (33.3)	.344 (8.7)	.562 (14.3)
27	13	3.114 (79.1)	5.682 (144.3)	1.312 (33.3)	.375 (9.5)	.625 (15.9)
28	15	3.114 (79.1)	5.682 (144.3)	1.312 (33.3)	.375 (9.5)	.625 (15.9)

TABLE I: Shell Size and Dimensions

Shell Size	A Thread Class 2B	C Dia Max
11	.750 - 20 UNEF	1.028 (26.1)
13	.875 - 20 UNEF	1.141 (29.0)
15	1.000 - 20 UNEF	1.263 (32.1)
17	1.125 - 18 UNEF	1.387 (35.2)
19	1.250 - 18 UNEF	1.513 (38.4)
23	1.438 - 18 UNEF	1.703 (43.3)
25	1.562 - 18 UNEF	1.825 (46.4)
29	1.875 - 16 UN	2.143 (54.4)
33	2.062 - 16 UNS	2.329 (59.2)

APPLICATION NOTES

- For complete dimensions see the applicable Military Specification.
- Metric dimensions (mm) are in parentheses.
- Cable Range is defined as the accommodation range for the wire bundle or cable. Dimensions shown are not intended for inspection criteria.

Dimensions in inches (millimeters) and are subject to change without notice.

MIL-DTL-28840/8 Style B 90° Environmental Backshell



MIL-DTL-28840

CONNECTOR DESIGNATOR:

G MIL-DTL-28840

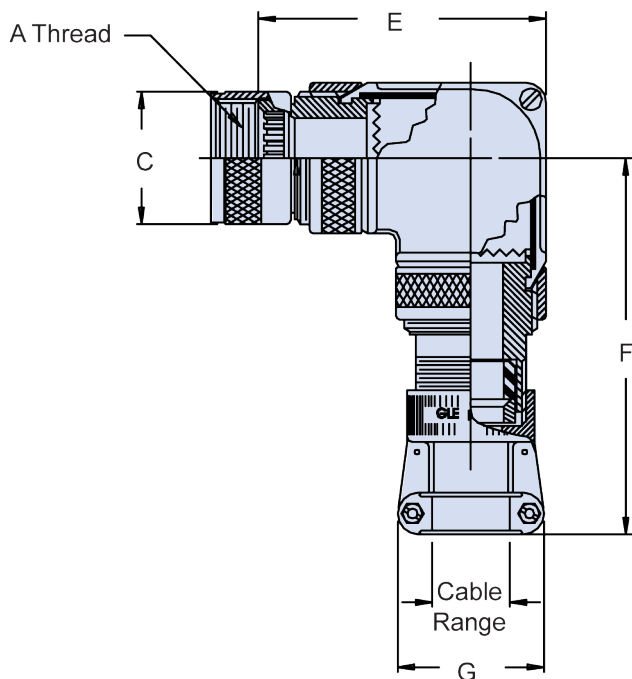
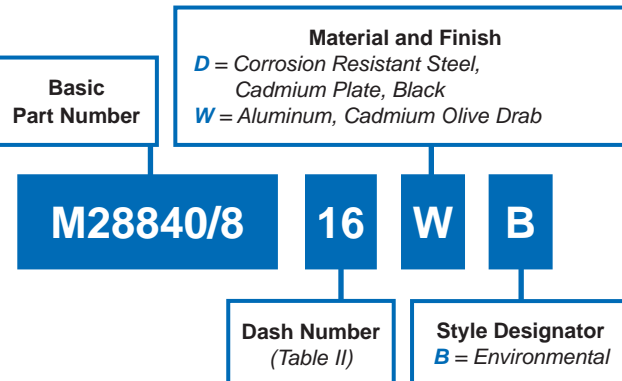

TABLE I: Shell Size

Shell Size	A Thread Class 2B	C Dia Max
11	.750 - 20 UNEF	1.030 (26.2)
13	.875 - 20 UNEF	1.140 (29.0)
15	1.000 - 20 UNEF	1.260 (32.0)
17	1.125 - 18 UNEF	1.390 (35.3)
19	1.250 - 18 UNEF	1.510 (38.4)
23	1.438 - 18 UNEF	1.700 (43.2)
25	1.563 - 18 UNEF	1.820 (46.2)
29	1.875 - 16 UN	2.140 (54.4)
33	2.063 - 16 UNS	2.330 (59.2)

TABLE II: Dash Number and Dimensions

Dash No.	Shell Size Ref.	E Max Envelope	F Max	G Ref. Dim	Cable Range	
					Min	Max
01	11	2.614 (66.4)	2.962 (75.2)	.938 (23.8)	.188 (4.8)	.312 (7.9)
02	13	2.614 (66.4)	2.962 (75.2)	.938 (23.8)	.188 (4.8)	.312 (7.9)
03	13	2.614 (66.4)	2.962 (75.2)	1.125 (28.6)	.281 (7.1)	.438 (11.1)
04	15	2.864 (72.7)	3.087 (78.4)	.938 (23.8)	.188 (4.8)	.312 (7.9)
05	15	2.864 (72.7)	3.087 (78.4)	1.125 (28.6)	.281 (7.1)	.438 (11.1)
06	15	2.864 (72.7)	3.087 (78.4)	1.312 (33.3)	.344 (8.7)	.562 (14.3)
07	15	3.114 (79.1)	3.312 (84.1)	1.593 (40.5)	.438 (11.1)	.750 (19.1)
08	17	3.114 (79.1)	3.312 (84.1)	1.312 (33.3)	.375 (9.5)	.625 (15.9)
09	17	3.114 (79.1)	3.343 (84.9)	1.593 (40.5)	.438 (11.1)	.750 (19.1)
10	17	3.114 (79.1)	3.437 (87.3)	1.750 (44.5)	.625 (15.9)	.938 (23.8)
11	19	3.114 (79.1)	3.312 (84.1)	1.312 (33.3)	.375 (9.5)	.625 (15.9)
12	19	3.364 (85.4)	3.462 (87.9)	1.750 (44.5)	.625 (15.9)	.938 (23.8)
13	23	3.364 (85.4)	3.368 (85.5)	1.593 (40.5)	.438 (11.1)	.750 (19.1)
14	23	3.364 (85.4)	3.462 (87.9)	1.750 (44.5)	.625 (15.9)	.938 (23.8)
15	23	3.364 (85.4)	3.649 (92.7)	2.093 (53.2)	.812 (20.6)	1.188 (30.2)
16	25	3.364 (85.4)	3.462 (87.9)	1.750 (44.5)	.625 (15.9)	.938 (23.8)
17	25	3.364 (85.4)	3.649 (92.7)	2.093 (53.2)	.812 (20.6)	1.188 (30.2)
18	25	3.614 (91.8)	3.774 (95.9)	2.093 (53.2)	.875 (22.2)	1.250 (31.8)
19	25	3.614 (91.8)	3.806 (96.7)	2.343 (59.5)	1.000 (25.4)	1.380 (35.1)
20	29	3.614 (91.8)	3.774 (95.9)	2.093 (53.2)	.812 (20.6)	1.188 (30.2)
21	29	3.614 (91.8)	3.806 (96.7)	2.343 (59.5)	1.000 (25.4)	1.380 (35.1)
22	33	4.114 (104.5)	4.056 (103.0)	2.343 (59.5)	1.000 (25.4)	1.380 (35.1)
23	33	4.114 (104.5)	4.331 (110.0)	2.750 (69.9)	1.250 (31.8)	1.625 (41.3)
24	11	2.614 (66.4)	2.962 (75.2)	1.125 (28.6)	.281 (7.1)	.438 (11.1)
25	11	2.864 (72.7)	3.087 (78.4)	1.312 (33.3)	.344 (8.7)	.562 (14.3)
26	13	2.864 (72.7)	3.087 (78.4)	1.312 (33.3)	.344 (8.7)	.562 (14.3)
27	13	3.114 (79.1)	3.312 (84.1)	1.312 (33.3)	.375 (9.5)	.625 (15.9)
28	15	3.114 (79.1)	3.312 (84.1)	1.312 (33.3)	.375 (9.5)	.625 (15.9)

APPLICATION NOTES

- For complete dimensions see the applicable Military Specification.
- Metric dimensions (mm) are in parentheses.
- Cable Range is defined as the accommodation range for the wire bundle or cable. Dimensions shown are not intended for inspection criteria.

Dimensions in inches (millimeters) and are subject to change without notice.

© 2013 Glenair, Inc.

U.S. CAGE Code 06324

Printed in U.S.A.



MIL-DTL-28840/9 Style A 45° EMI/RFI Environmental Backshell

CONNECTOR DESIGNATOR:

G MIL-DTL-28840

Material and Finish

D = Corrosion Resistant Steel, Cadmium Plate, Black
W = Aluminum, Cadmium Olive Drab

M28840/9

16

W

A

Basic
Part
Number

Dash No.
(Table II)

Style
A = EMI/Environmental

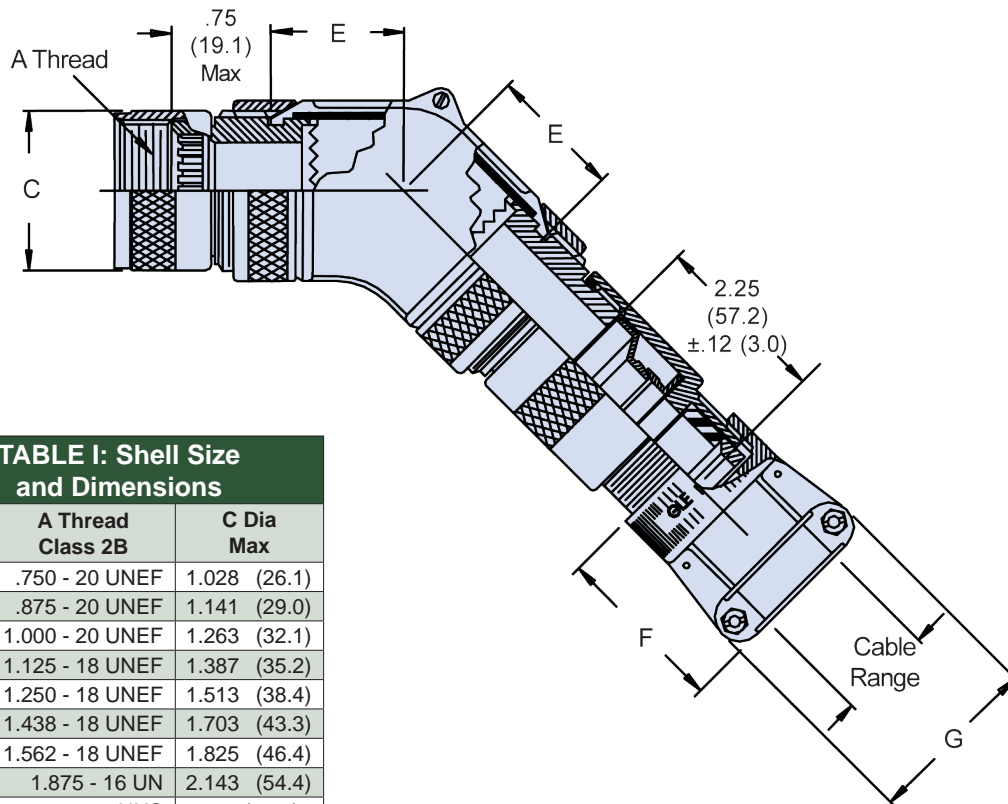

TABLE I: Shell Size and Dimensions

Shell Size	A Thread Class 2B	C Dia Max
11	.750 - 20 UNEF	1.028 (26.1)
13	.875 - 20 UNEF	1.141 (29.0)
15	1.000 - 20 UNEF	1.263 (32.1)
17	1.125 - 18 UNEF	1.387 (35.2)
19	1.250 - 18 UNEF	1.513 (38.4)
23	1.438 - 18 UNEF	1.703 (43.3)
25	1.562 - 18 UNEF	1.825 (46.4)
29	1.875 - 16 UN	2.143 (54.4)
33	2.062 - 16 UNS	2.329 (59.2)

APPLICATION NOTES

- For complete dimensions see the applicable Military Specification.
- Metric dimensions (mm) are in parentheses.
- Cable Range is defined as the accommodation range for the wire bundle or cable. Dimensions shown are not intended for inspection criteria.

Dimensions in inches (millimeters) and are subject to change without notice.

MIL-DTL-28840/9 45° Environmental Backshell Style B



MIL-DTL-28840

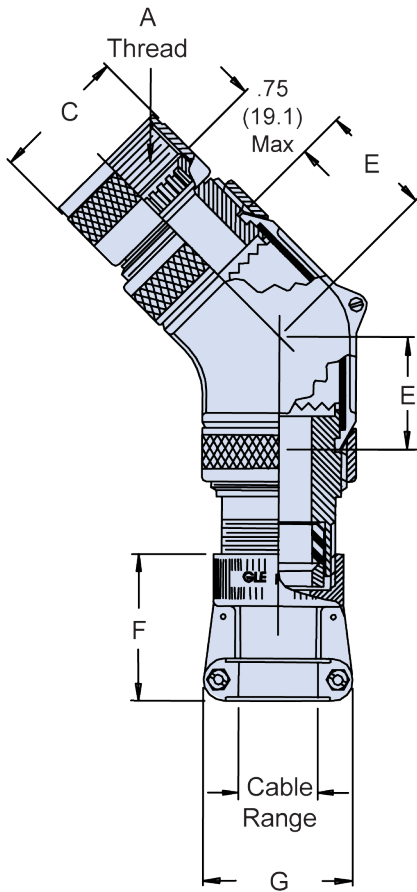

CONNECTOR DESIGNATOR:	
G	MIL-DTL-28840

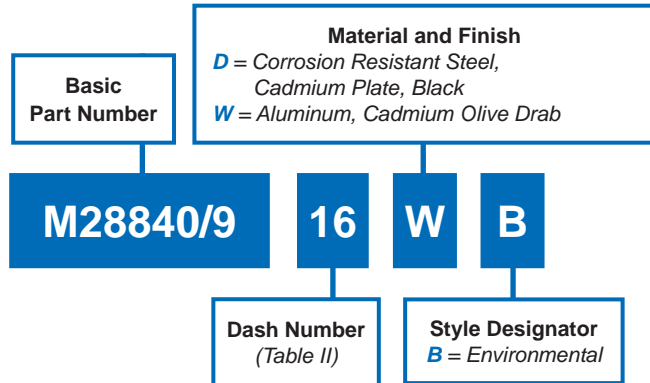

Shell Size	A Thread Class 2B	C Dia Max
11	.750 - 20 UNEF	1.030 (26.2)
13	.875 - 20 UNEF	1.140 (29.0)
15	1.000 - 20 UNEF	1.260 (32.0)
17	1.125 - 18 UNEF	1.390 (35.3)
19	1.250 - 18 UNEF	1.510 (38.4)
23	1.438 - 18 UNEF	1.700 (43.2)
25	1.563 - 18 UNEF	1.820 (46.2)
29	1.875 - 16 UN	2.140 (54.4)
33	2.063 - 16 UNS	2.330 (59.2)

Dash No.	Shell Size Ref.	E Max	F Ref. Dim	G Ref. Dim	Cable Range	
					Min	Max
01	11	1.031 (26.2)	1.281 (32.5)	.938 (23.8)	.188 (4.8)	.312 (7.9)
02	13	1.031 (26.2)	1.281 (32.5)	.938 (23.8)	.188 (4.8)	.312 (7.9)
03	13	1.031 (26.2)	1.281 (32.5)	1.125 (28.6)	.281 (7.1)	.438 (11.1)
04	15	1.156 (29.4)	1.281 (32.5)	.938 (23.8)	.188 (4.8)	.312 (7.9)
05	15	1.156 (29.4)	1.281 (32.5)	1.125 (28.6)	.281 (7.1)	.438 (11.1)
06	15	1.156 (29.4)	1.281 (32.5)	1.312 (33.3)	.344 (8.7)	.562 (14.3)
07	15	1.281 (32.5)	1.312 (33.3)	1.593 (40.5)	.438 (11.1)	.750 (19.1)
08	17	1.281 (32.5)	1.281 (32.5)	1.312 (33.3)	.375 (9.5)	.625 (15.9)
09	17	1.281 (32.5)	1.312 (33.3)	1.593 (40.5)	.438 (11.1)	.750 (19.1)
10	17	1.281 (32.5)	1.406 (35.7)	1.750 (44.5)	.625 (15.9)	.938 (23.8)
11	19	1.281 (32.5)	1.281 (32.5)	1.312 (33.3)	.375 (9.5)	.625 (15.9)
12	19	1.406 (35.7)	1.406 (35.7)	1.750 (44.5)	.625 (15.9)	.938 (23.8)
13	23	1.406 (35.7)	1.312 (33.3)	1.593 (40.5)	.438 (11.1)	.750 (19.1)
14	23	1.406 (35.7)	1.406 (35.7)	1.750 (44.5)	.625 (15.9)	.938 (23.8)
15	23	1.406 (35.7)	1.593 (40.5)	2.093 (53.2)	.812 (20.6)	1.188 (30.2)
16	25	1.406 (35.7)	1.406 (35.7)	1.750 (44.5)	.625 (15.9)	.938 (23.8)
17	25	1.406 (35.7)	1.593 (40.5)	2.093 (53.2)	.812 (20.6)	1.188 (30.2)
18	25	1.531 (38.9)	1.593 (40.5)	2.093 (53.2)	.875 (22.2)	1.250 (31.8)
19	25	1.531 (38.9)	1.625 (41.3)	2.343 (59.5)	1.000 (25.4)	1.380 (35.1)
20	29	1.531 (38.9)	1.593 (40.5)	2.093 (53.2)	.812 (20.6)	1.188 (30.2)
21	29	1.531 (38.9)	1.625 (41.3)	2.343 (59.5)	1.000 (25.4)	1.380 (35.1)
22	33	1.781 (45.2)	1.625 (41.3)	2.343 (59.5)	1.000 (25.4)	1.380 (35.1)
23	33	1.781 (45.2)	1.900 (48.3)	2.750 (69.9)	1.250 (31.8)	1.625 (41.3)
24	11	1.031 (26.2)	1.281 (32.5)	1.125 (28.6)	.281 (7.1)	.438 (11.1)
25	11	1.156 (29.4)	1.281 (32.5)	1.312 (33.3)	.344 (8.7)	.562 (14.3)
26	13	1.156 (29.4)	1.281 (32.5)	1.312 (33.3)	.344 (8.7)	.562 (14.3)
27	13	1.281 (32.5)	1.281 (32.5)	1.312 (33.3)	.375 (9.5)	.625 (15.9)
28	15	1.281 (32.5)	1.281 (32.5)	1.312 (33.3)	.375 (9.5)	.625 (15.9)

APPLICATION NOTES

- For complete dimensions see the applicable Military Specification.
- Metric dimensions (mm) are in parentheses.
- Cable Range is defined as the accommodation range for the wire bundle or cable. Dimensions shown are not intended for inspection criteria.

Dimensions in inches (millimeters) and are subject to change without notice.

D

M28840/13 and M28840/15 Protective Plug and Receptacle Covers

MATING CONNECTOR

MIL-DTL-28840

Basic Part Number

M28840/13 = Receptacle Cover
M28840/15 = Plug Cover

Shell Size Designator

M28840/13**H****A****W**

Material and Finish

D = Corrosion Resistant Steel,
Cadmium Plate, Black
W = Aluminum, 500 Hour, Cadmium O.D.

APPLICATION NOTES

1. Assembly identified with manufacturer's name and part number, space permitting.
2. For complete dimensions, see the applicable Military Specification.
3. Metric dimensions (mm) are in parentheses.

Attachment Style

A = Chain with Fastener
B = Chain with Ring for Jam Nut Receptacle (M28840/13 Only)
B = Chain with Ring (M28840/15 Only)
C = Chain with Ring for Cable Receptacle (M28840/13 Only)

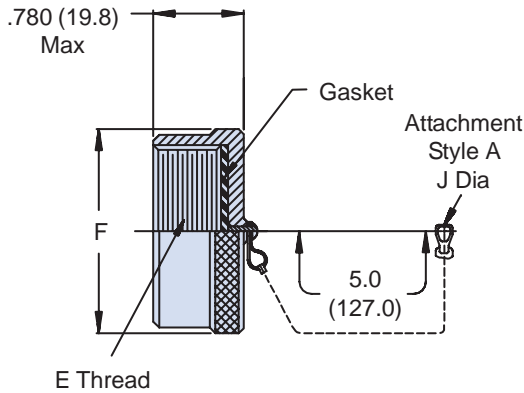

M28840/13 Receptacle Cover

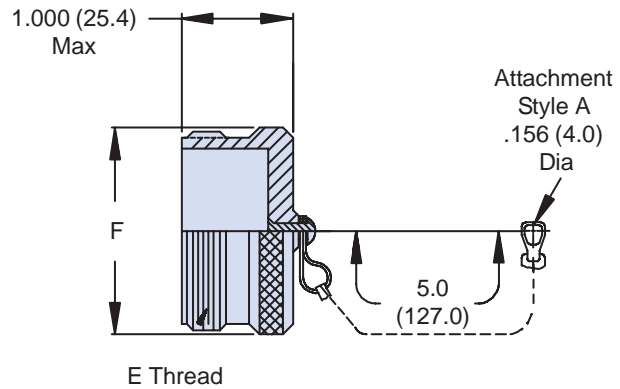

M28840/15 Plug Cover

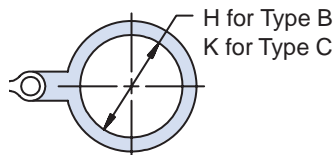

M28840/13 Attachment Types B & C

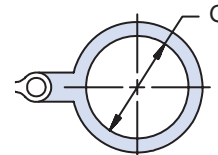

M28840/15 Attachment Type B

TABLE I: Shell Size Designator, Thread and Dimensions

Shell Size Desig.	Shell Size Ref.	E Thread	F Max	G Dia ± .010 (0.3)	H Dia ± .010 (0.3)	J Dia ± .005 (0.1)	K Dia ± .010 (0.3)
A	11	0.750-0.1P-0.2L-DS	1.028 (26.1)	.765 (19.4)	.890 (22.6)	.130 (3.3)	.765 (19.4)
B	13	0.875-0.1P-0.2L-DS	1.141 (29.0)	.890 (22.6)	1.015 (25.8)	.130 (3.3)	.890 (22.6)
C	15	1.062-0.1P-0.2L-DS	1.263 (32.1)	1.015 (25.8)	1.203 (30.6)	.130 (3.3)	1.015 (25.8)
D	17	1.125-0.1P-0.2L-DS	1.387 (35.2)	1.140 (29.0)	1.265 (32.1)	.130 (3.3)	1.140 (29.0)
E	19	1.312-0.1P-0.2L-DS	1.513 (38.4)	1.265 (32.1)	1.453 (36.9)	.130 (3.3)	1.265 (32.1)
F	23	1.500-0.1P-0.2L-DS	1.703 (43.3)	1.453 (36.9)	1.640 (41.7)	.130 (3.3)	1.453 (36.9)
G	25	1.625-0.1P-0.2L-DS	1.825 (46.4)	1.577 (40.1)	1.765 (44.8)	.156 (4.0)	1.577 (40.1)
H	29	1.812-0.1P-0.2L-DS	2.143 (54.4)	1.890 (48.0)	1.953 (49.6)	.156 (4.0)	1.890 (48.0)
J	33	2.000-0.1P-0.2L-DS	2.329 (59.2)	2.077 (52.8)	2.140 (54.4)	.193 (4.9)	2.077 (52.8)

Dimensions in inches (millimeters) and are subject to change without notice.

M28840/22 Metal Core Conduit Bushing



MIL-DTL-28840

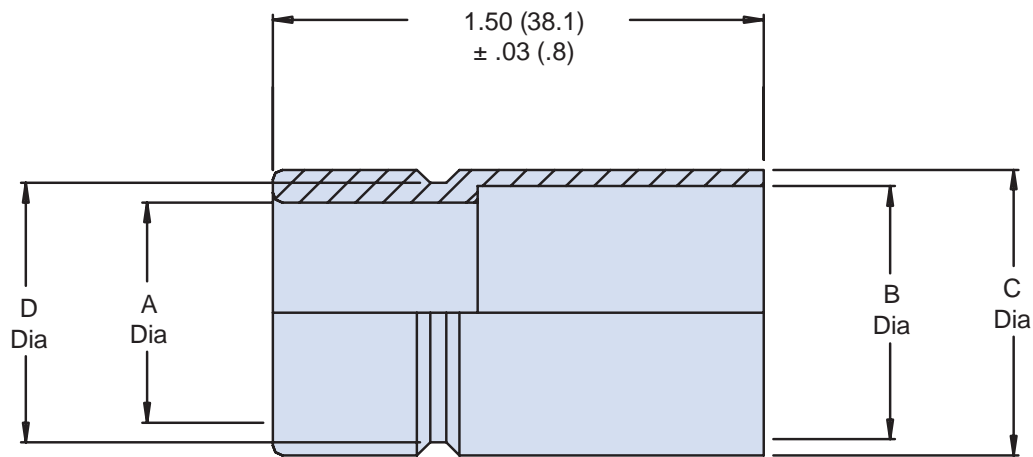
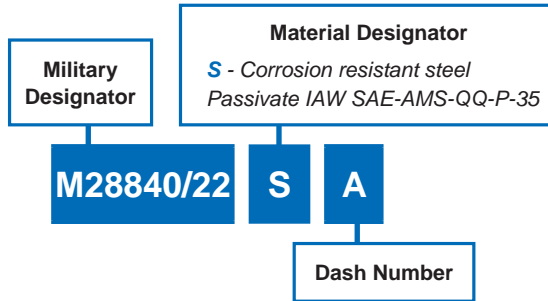

D

Size	MIL- DTL-28840/04 Size Ref.	A +.020 (.50) -.000 (.000)	B +.005 (.12) -.000 (.000)	C +.000 (.000) -.005 (.12)	D +.000 (.000) -.005 (.12)
03	03	.375 (9.53)	.540 (13.71)	.625 (15.87)	.525 (13.34)
04	04	.500 (12.70)	.665 (16.89)	.750 (19.05)	.650 (16.51)
05	05	.625 (15.87)	.780 (19.81)	.875 (22.23)	.775 (19.69)
06	06	.750 (19.05)	.940 (23.88)	1.000 (25.40)	.900 (22.86)
08	08	1.000 (25.40)	1.225 (31.12)	1.375 (34.93)	1.275 (32.39)
10	10	1.250 (31.75)	1.470 (37.34)	1.625 (41.28)	1.525 (38.74)
12	12	1.500 (38.10)	1.740 (44.20)	1.875 (47.65)	1.775 (45.09)
16	16	2.000 (50.80)	2.215 (56.26)	2.375 (60.33)	2.275 (57.79)

Dimensions in inches (millimeters) and are subject to change without notice.



MIL-DTL-28840/23 Non-Self-Locking E-Nut

CONNECTOR DESIGNATOR:
G MIL-DTL-28840

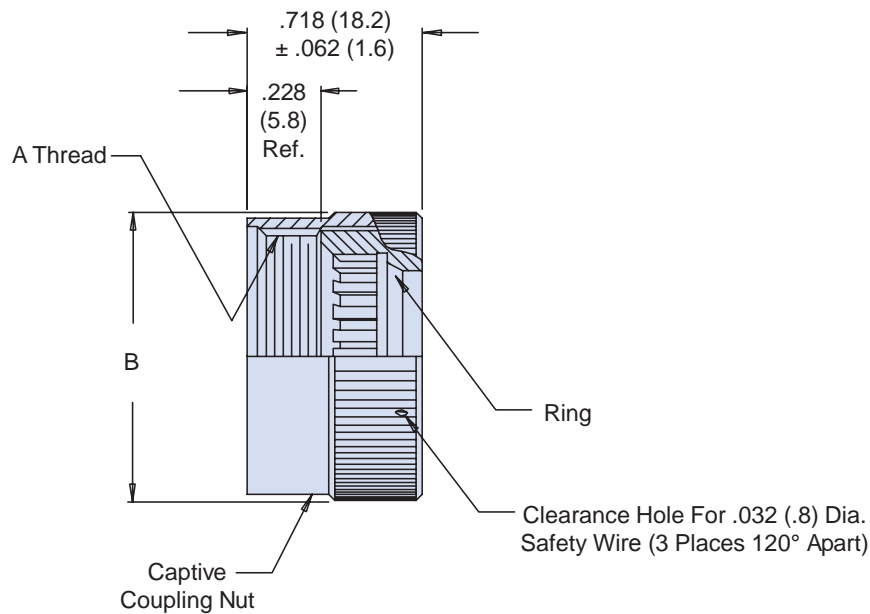
**Basic Part
Number**
**Shell
Size**
M28840/23
- J
W
Material and Finish
*D = Corrosion Resistant Steel,
Cadmium Plate, Black*
W = Aluminum, Cadmium Olive Drab

TABLE I: Shell Size, Shell Size Ref, Thread and Dimensions

Shell Size	Shell Size Ref.	A Thread Class 2B	Ø B Max
A	11	.750 - 20 UNEF	1.028 (26.1)
B	13	.875 - 20 UNEF	1.141 (29.0)
C	15	1.000 - 20 UNEF	1.263 (32.1)
D	17	1.125 - 18 UNEF	1.387 (35.2)
E	19	1.250 - 18 UNEF	1.513 (38.4)
F	23	1.438 - 18 UNEF	1.703 (43.3)
G	25	1.562 - 18 UNEF	1.825 (46.4)
H	29	1.875 - 16 UN	2.143 (54.4)
J	33	2.062 - 16 UNS	2.329 (59.2)

APPLICATION NOTES

1. Assembly to be identified with manufacturer's name and part number, space permitting.
2. For complete dimensions, see the applicable Military Specification.
3. Cable entry is defined as the accommodation range for the wire bundle or cable. Dimensions shown are not intended for inspection criteria.
4. Metric dimensions (mm) are in parentheses.

Dimensions in inches (millimeters) and are subject to change without notice.

M28840/24 Gasket



MIL-DTL-28840

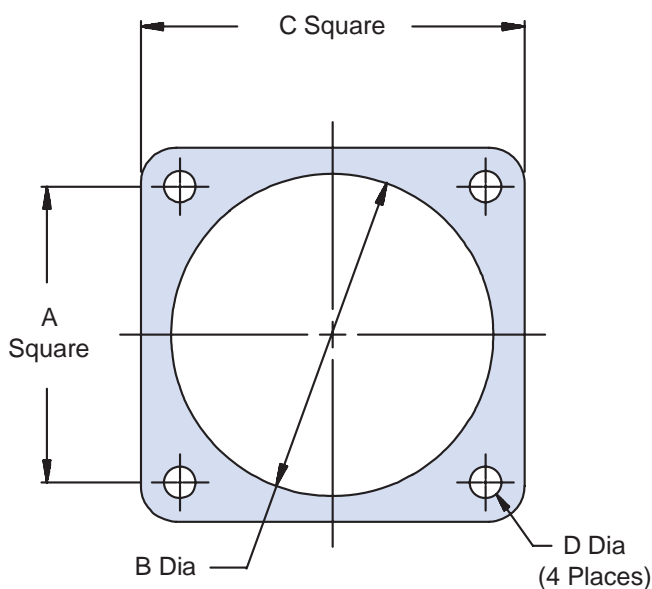
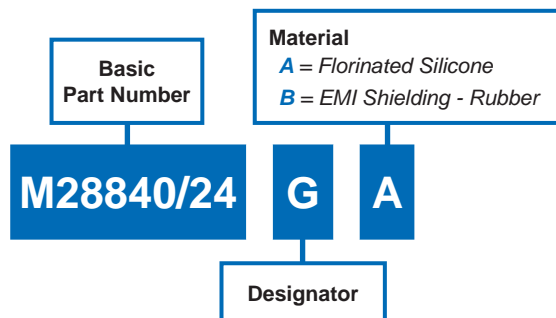

D

TABLE I: Reference for Connector Shell Size

Designator	Shell Size	A Sq.		Ø B		C Sq.		Ø D	
		±.010	(.3)	±.008	(.2)	±.008	(.2)	±.010	(.3)
A	11	.750	(19.1)	.758	(19.3)	1.031	(26.2)	.120	(3.0)
B	13	.843	(21.4)	.883	(22.4)	1.146	(29.1)	.120	(3.0)
C	15	.968	(24.6)	1.070	(27.2)	1.266	(32.2)	.120	(3.0)
D	17	1.015	(25.8)	1.133	(28.8)	1.391	(35.3)	.120	(3.0)
E	19	1.140	(29.0)	1.320	(33.5)	1.516	(38.5)	.120	(3.0)
F	23	1.281	(32.5)	1.508	(38.3)	1.726	(43.8)	.120	(3.0)
G	25	1.392	(35.4)	1.633	(41.5)	1.826	(46.4)	.147	(3.7)
H	29	1.568	(39.8)	1.883	(47.8)	2.146	(54.5)	.147	(3.7)
J	33	1.734	(44.0)	2.070	(52.6)	2.336	(59.3)	.173	(4.4)

- APPLICATION NOTES**
1. Assembly identified with manufacturer's name and part number, space permitting.
 2. For complete dimensions, see the applicable Military Specification.
 3. Metric dimensions (mm) are in parentheses.

Dimensions in inches (millimeters) and are subject to change without notice.

WHY GLENAIR?

ANOTHER GOOD REASON

**TO SOURCE YOUR BACKSHELLS
FROM GLENAIR**



Every Connector Accessory There Is!

“NO GAPS”

**Glenair supplies every active MS backshell and connector
accessory—no gaps—most with same-day availability**



MIL-DTL-83723

Qualified Backshells and Connector Accessories



MIL-DTL-83723

Industry Specification Number	Part Identification Number	Military Part Number Superseded	Glenair Commercial Part Number	Description	Glenair Connector Designator/Interface	Page No.
MIL-DTL-83723/27	M83723/27M	---	310KS002	Straight Shrink Boot Adapter	"K" MIL-DTL-83723 Series II	E-2
MIL-DTL-83723/35	M83723/35S M83723/35A M83723/35N	---	Consult Factory	Strt. Non-Environmental Strain Relief Backshell 90° Non-Environmental Strain Relief Backshell Non-Self-Locking E-Nut	"K" MIL-DTL-83723 Series II	E-3 E-4 E-5
MIL-DTL-83723/50	M83723/50 R M83723/50 B M83723/50 A	---	Consult Factory	Straight Qwik-Ty® Strain Relief 45° Qwik-Ty® Strain Relief 90° Qwik-Ty® Strain Relief	"K" MIL-DTL-83723 Series II	E-6
MIL-DTL-83723/59 MIL-DTL-83723/60	M83723/59-1 M83723/60-1	MS27292 MS27293	660-021 660-022	Protective Plug Cover, Threaded Coupling Protective Receptacle Cover, Threaded Coupling	MIL-DTL-83723, Series III	E-7
MIL-DTL-83723/59 MIL-DTL-83723/60	M83723/59-2 M83723/60-2	MS27294 MS27295	660-019 660-020	Protective Plug Cover Bayonet Coupling Protective Receptacle Cover Bayonet Coupling	MIL-DTL-83723, Series III	E-8
MIL-DTL-83723/70	M83723/70	---	Consult Factory	Straight Quick Disconnect Receptacle Adapter	---	E-9

E

Dimensions in inches (millimeters) and are subject to change without notice.

© 2013 Glenair, Inc.

U.S. CAGE Code 06324

Printed in U.S.A.

GLENAIR, INC. • 1211 AIR WAY • GLENDALE, CA 91201-2497 • 818-247-6000 • FAX 818-500-9912
www.glenair.com E-1 E-Mail: sales@glenair.com



M83723/27M

Straight Shrink Boot Adapter

CONNECTOR DESIGNATOR:
K MIL-DTL-83723 Series II

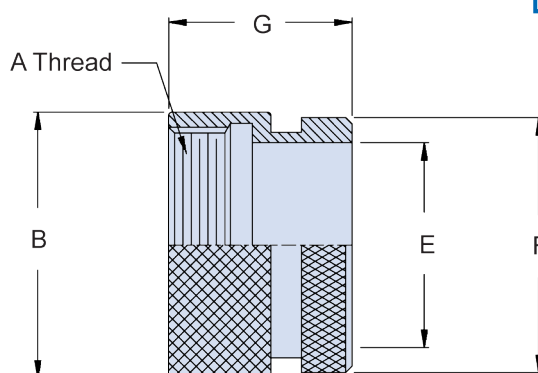
**Basic
Part Number**
**Shell
Size**
M83723/27M
22
M
**Backshell
Only**

TABLE I: Adapter Size, Shell Size, Thread and Dimensions

Adapter Size	Shell Size Ref.	A Thread Class 2B	B Dia Max	E Dia	F Dia Min	G Max
08	8S	.438 - 28 UNEF	.580 (14.7)	.250 (6.4)	.479 (12.2)	.830 (21.1)
10	10S	.500 - 28 UNEF	.640 (16.3)	.303 (7.7)	.539 (13.7)	.830 (21.1)
11	10SL	.562 - 24 UNEF	.700 (17.8)	.383 (9.7)	.608 (15.4)	.830 (21.1)
12	12	.625 - 24 UNEF	.760 (19.3)	.408 (10.4)	.659 (16.7)	.830 (21.1)
13	12S	.625 - 24 UNEF	.760 (19.3)	.408 (10.4)	.659 (16.7)	.830 (21.1)
14	14	.750 - 20 UNEF	.890 (22.6)	.490 (12.4)	.782 (19.9)	.830 (21.1)
16	14S	.750 - 20 UNEF	.890 (22.6)	.490 (12.4)	.782 (19.9)	.830 (21.1)
16	16	.875 - 20 UNEF	1.010 (25.7)	.609 (15.5)	.908 (23.1)	.996 (25.3)
17	16S	.875 - 20 UNEF	1.010 (25.7)	.609 (15.5)	.908 (23.1)	.830 (21.1)
18	18	1.000 - 20 UNEF	1.140 (29.0)	.730 (18.5)	1.025 (26.0)	.996 (25.3)
20	20	1.125 - 18 UNEF	1.260 (32.0)	.870 (22.1)	1.212 (30.8)	.996 (25.3)
22	22	1.250 - 18 UNEF	1.390 (35.3)	.978 (24.8)	1.343 (34.1)	.996 (25.3)
24	24	1.375 - 18 UNEF	1.520 (38.6)	1.090 (27.7)	1.450 (36.8)	.996 (25.3)
28	28	1.625 - 18 UNEF	1.760 (44.7)	1.250 (31.8)	1.671 (42.4)	1.076 (27.3)
32	32	1.875 - 16 UN	2.010 (51.1)	1.520 (38.6)	1.956 (49.7)	1.076 (27.3)
36	36	2.125 - 16 UN	2.260 (57.4)	1.756 (44.6)	2.164 (55.0)	1.076 (27.3)
40	40	2.375 - 16 UN	2.510 (63.8)	1.880 (47.8)	2.500 (63.5)	1.222 (31.0)

APPLICATION NOTES

- For complete dimensions see the applicable Military Specification.
- Finish: Electroless Nickel.
- Metric dimensions (mm) are in parentheses.

Dimensions in inches (millimeters) and are subject to change without notice.

M83723/35S Straight Non-Environmental Strain Relief Backshell



MIL-DTL-83723

CONNECTOR DESIGNATOR:	
K	MIL-DTL-83723 Series II

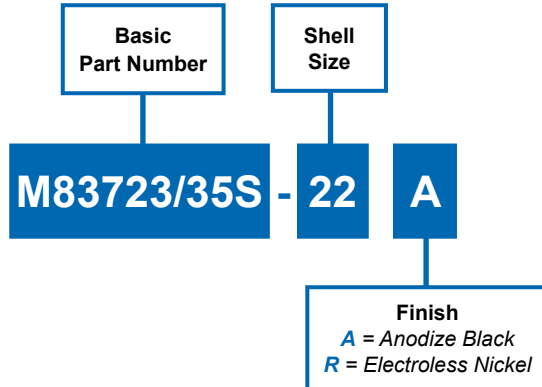

- APPLICATION NOTES**
- For complete dimensions see the applicable Military Specification.
 - Metric dimensions (mm) are in parentheses.
 - Cable Range is defined as the accommodation range for the wire bundle or cable. Dimensions shown are not intended for inspection criteria.

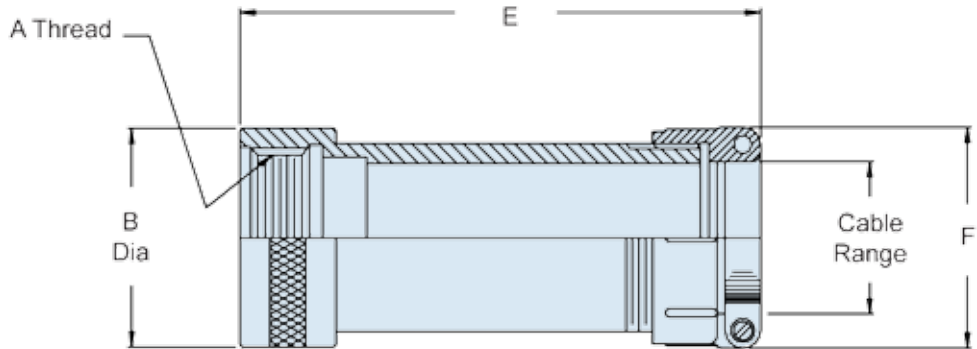

Shell Size	Shell Size (s) (Ref)	A Thread Class 2B	B Dia Max	E Max	F Max	Cable Range	
						Min	Max
08	8S	.438 - 28 UNEF	.585 (14.9)	1.290 (32.8)	.843 (21.4)	.125 (3.2)	.235 (6.0)
10	10S	.500 - 28 UNEF	.645 (16.4)	1.290 (32.8)	.843 (21.4)	.125 (3.2)	.235 (6.0)
11	10SL	.562 - 24 UNEF	.730 (18.5)	1.290 (32.8)	.906 (23.0)	.170 (4.3)	.297 (7.5)
13	12 & 12S	.625 - 24 UNEF	.770 (19.6)	1.290 (32.8)	1.085 (27.6)	.170 (4.3)	.297 (7.5)
15	14 & 14S	.750 - 20 UNEF	.910 (23.1)	1.368 (34.7)	1.093 (27.8)	.235 (6.0)	.422 (10.7)
16	16	.875 - 20 UNEF	1.035 (26.3)	1.587 (40.3)	1.275 (32.4)	.295 (7.5)	.547 (13.9)
17	16S	.875 - 20 UNEF	1.035 (26.3)	1.430 (36.3)	1.187 (30.1)	.295 (7.5)	.547 (13.9)
18	18	1.000 - 20 UNEF	1.170 (29.7)	1.695 (43.1)	1.475 (37.5)	.325 (8.3)	.610 (15.5)
20	20	1.125 - 18 UNEF	1.300 (33.0)	1.695 (43.1)	1.500 (38.1)	.380 (9.7)	.735 (18.7)
22	22	1.250 - 18 UNEF	1.420 (36.1)	1.695 (43.1)	1.710 (43.4)	.380 (9.7)	.735 (18.7)
24	24	1.375 - 18 UNEF	1.535 (39.0)	1.931 (49.0)	1.719 (43.7)	.500 (12.7)	.922 (23.4)
28	28	1.625 - 18 UNEF	1.800 (45.7)	1.931 (49.0)	2.040 (51.8)	.500 (12.7)	.922 (23.4)
32	32	1.875 - 16 UNEF	2.035 (51.6)	1.869 (47.5)	2.332 (59.2)	.705 (17.9)	1.235 (31.4)
36	36	2.125 - 16 UN	2.270 (57.7)	1.869 (47.5)	2.312 (58.7)	.725 (18.4)	1.360 (34.5)
40	40	2.375 - 16 UN	2.780 (70.6)	2.875 (73.0)	2.950 (74.9)	.911 (23.1)	1.630 (41.4)

Dimensions in inches (millimeters) and are subject to change without notice.



M83723/35A

90° Non-Environmental Strain Relief Backshell

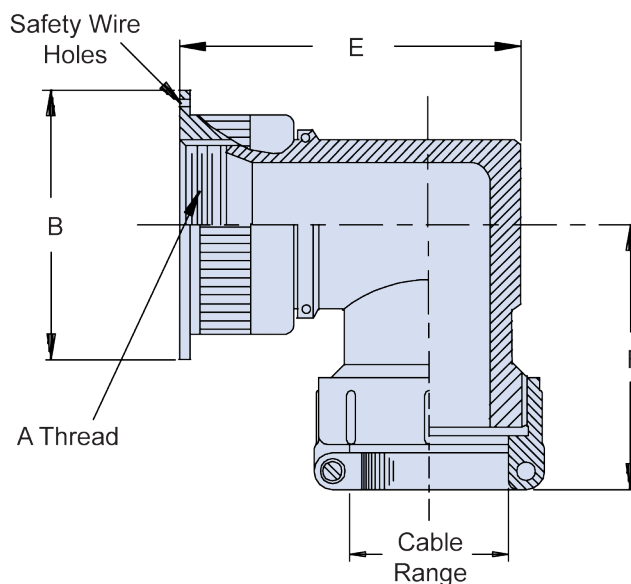
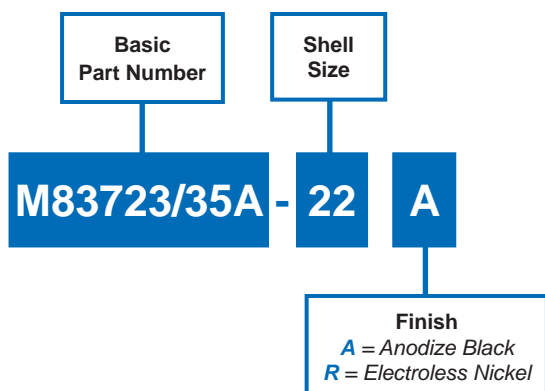
CONNECTOR DESIGNATOR:
K MIL-DTL-83723 Series II

TABLE I: Shell Size, Cable Range and Dimensions

Shell Size	A Thread Class 2B	B Dia Max	E Max	F Max	Cable Range	
					Min	Max
08	.438 - 28 UNEF	.805 (20.4)	1.187 (30.1)	1.220 (31.0)	.102 (2.6)	.235 (6.0)
10	.500 - 28 UNEF	.890 (22.6)	1.187 (30.1)	1.250 (31.8)	.102 (2.6)	.235 (6.0)
11	.562 - 24 UNEF	.975 (24.8)	1.312 (33.3)	1.280 (32.5)	.140 (3.6)	.297 (7.5)
13	.625 - 24 UNEF	1.005 (25.5)	1.312 (33.3)	1.280 (32.5)	.140 (3.6)	.297 (7.5)
12	.625 - 24 UNEF	1.005 (25.5)	1.468 (37.3)	1.280 (32.5)	.140 (3.6)	.297 (7.5)
15	.750 - 20 UNEF	1.130 (28.7)	1.437 (36.5)	1.405 (35.7)	.195 (5.0)	.422 (10.7)
14	.750 - 20 UNEF	1.130 (28.7)	1.594 (40.5)	1.405 (35.7)	.195 (5.0)	.422 (10.7)
17	.875 - 20 UNEF	1.255 (31.9)	1.531 (38.9)	1.529 (38.8)	.255 (6.5)	.547 (13.9)
16	.875 - 20 UNEF	1.255 (31.9)	1.687 (42.8)	1.529 (38.8)	.255 (6.5)	.547 (13.9)
18	1.000 - 20 UNEF	1.350 (34.3)	1.765 (44.8)	1.593 (40.5)	.285 (7.2)	.610 (15.5)
20	1.125 - 18 UNEF	1.475 (37.5)	2.000 (50.8)	1.655 (42.0)	.350 (8.9)	.735 (18.7)
22	1.250 - 18 UNEF	1.600 (40.6)	2.000 (50.8)	1.718 (43.6)	.350 (8.9)	.735 (18.7)
24	1.375 - 18 UNEF	1.725 (43.8)	2.265 (57.5)	1.894 (48.1)	.468 (11.9)	.922 (23.4)
28	1.625 - 18 UNEF	1.975 (50.2)	2.265 (57.5)	1.973 (50.1)	.468 (11.9)	.922 (23.4)
32	1.875 - 16 UN	2.225 (56.5)	2.578 (65.5)	2.187 (55.5)	.664 (16.9)	1.235 (31.4)
36	2.125 - 16 UN	2.475 (62.9)	2.815 (71.5)	2.405 (61.1)	.694 (17.6)	1.360 (34.5)
40	2.375 - 16 UN	2.750 (69.9)	5.800 (147.3)	5.100 (129.5)	.911 (23.1)	1.630 (41.4)

APPLICATION NOTES

- For complete dimensions see the applicable Military Specification.
- Metric dimensions (mm) are in parentheses.
- Cable Range is defined as the accommodation range for the wire bundle or cable. Dimensions shown are not intended for inspection criteria.

Dimensions in inches (millimeters) and are subject to change without notice.

M83723/35N Non-Self-Locking E-Nut



MIL-DTL-83723

CONNECTOR DESIGNATOR:	
K	MIL-DTL-83723 Series II

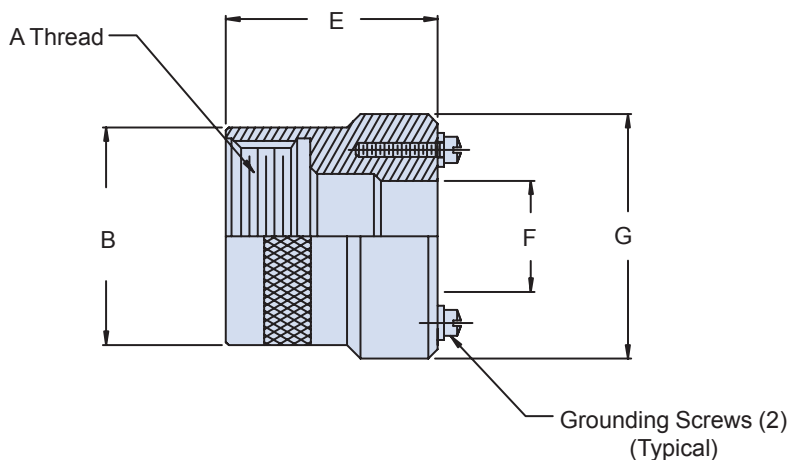
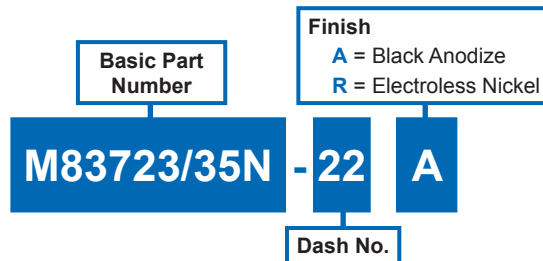

TABLE I: Dash Number, Shell Size, Thread and Dimensions

Dash No.	Shell Size Ref.	A Thread Class 2B	Ø B Max	E Max	F Max	G Max
08	8S	.438 - 28 UNEF	.59 (15.0)	.780 (19.8)	.257 (6.5)	.900 (22.9)
10	10S	.500 - 28 UNEF	.65 (16.5)	.780 (19.8)	.310 (7.9)	.900 (22.9)
11	10SL	.562 - 24 UNEF	.73 (18.5)	.780 (19.8)	.390 (9.9)	.980 (24.9)
13	12S	.625 - 24 UNEF	.77 (19.6)	.780 (19.8)	.415 (10.5)	.995 (25.3)
15	14S	.750 - 20 UNEF	.91 (23.1)	.780 (19.8)	.497 (12.6)	1.160 (29.5)
16	16	.875 - 20 UNEF	1.03 (26.2)	.970 (24.6)	.616 (15.6)	1.260 (32.0)
17	16S	.875 - 20 UNEF	1.03 (26.2)	.780 (19.8)	.616 (15.6)	1.260 (32.0)
18	18	1.000 - 20 UNEF	1.17 (29.7)	1.050 (26.7)	.735 (18.7)	1.455 (37.0)
20	33	1.125 - 18 UNEF	1.30 (33.0)	1.050 (26.7)	.875 (22.2)	1.580 (40.1)
22	20	1.250 - 18 UNEF	1.42 (36.1)	1.050 (26.7)	.983 (25.0)	1.580 (40.1)
24	22	1.375 - 18 UNEF	1.54 (39.1)	.970 (24.6)	1.095 (27.8)	1.890 (48.0)
28	28	1.625 - 18 UNEF	1.80 (45.7)	.970 (24.6)	1.255 (31.9)	1.890 (48.0)
32	32	1.875 - 16 UN	2.04 (51.8)	.970 (24.6)	1.525 (38.7)	2.215 (56.3)
36	36	2.125 - 16 UN	2.27 (57.7)	.970 (24.6)	1.760 (44.7)	2.405 (61.1)
40	40	2.375 - 16 UN	2.78 (70.6)	1.450 (36.8)	2.020 (51.3)	2.781 (70.6)

APPLICATION NOTES

- For complete dimensions, see the applicable Military Specification.
- Metric dimensions (mm) are indicated in parentheses.

Dimensions in inches (millimeters) and are subject to change without notice.

© 2013 Glenair, Inc.

Mil-Spec Backshells

U.S. CAGE Code 06324

Rev. 8.29.14

Printed in U.S.A.





M83723/50

Straight, 45° and 90° Qwik-Ty® Strain Reliefs

Non-Self-Locking

CONNECTOR DESIGNATOR:
K MIL-DTL-83723, Series II

Basic Part Number

M83723/50R = Straight
 M83723/50B = 45°
 M83723/50A = 90°

Angular Function

R = Straight
 B = 45°
 A = 90°

Shell Size
Finish

A = Black Anodize
 N = Electroless Nickel

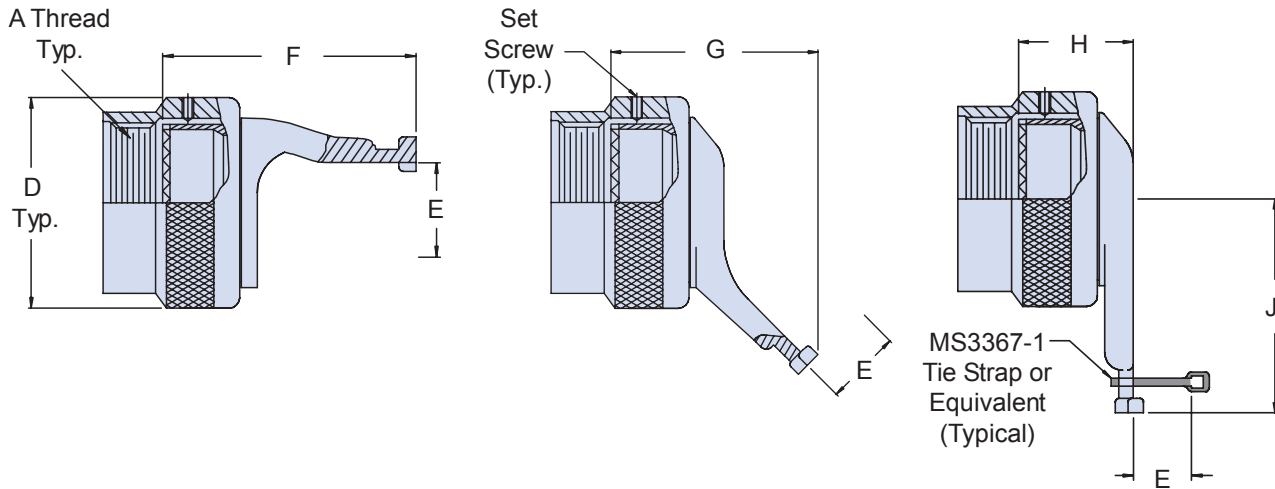
M83723/50
R
22
N

TABLE I: Shell Size, Thread, Cable Entry and Backshell Dimensions

Shell Size	A Thread Class 2B	D Dia Max	E Max Cable Entry	F Max	G Max	H Max	J Max
08	.438 - 28 UNEF	.620 (15.7)	.240 (6.1)	1.060 (26.9)	.740 (18.8)	.710 (18.0)	.880 (22.4)
10	.500 - 28 UNEF	.730 (18.5)	.295 (7.5)	1.060 (26.9)	.740 (18.8)	.710 (18.0)	.940 (23.9)
11	.562 - 24 UNEF	.730 (18.5)	.375 (9.5)	1.060 (26.9)	.740 (18.8)	.710 (18.0)	.940 (23.9)
12	.625 - 24 UNEF	.860 (21.8)	.400 (10.2)	1.120 (28.4)	.740 (18.8)	.710 (18.0)	1.000 (25.4)
13	.625 - 24 UNEF	.860 (21.8)	.400 (10.2)	1.120 (28.4)	.740 (18.8)	.710 (18.0)	1.000 (25.4)
14	.750 - 20 UNEF	.980 (24.9)	.482 (12.2)	1.300 (33.0)	2.010 (51.1)	.710 (18.0)	1.320 (33.5)
15	.750 - 20 UNEF	.980 (24.9)	.482 (12.2)	1.310 (33.3)	2.020 (51.3)	.710 (18.0)	1.320 (33.5)
16	.875 - 20 UNEF	1.110 (28.2)	.601 (15.3)	1.300 (33.0)	2.010 (51.1)	.710 (18.0)	1.370 (34.8)
17	.875 - 20 UNEF	1.110 (28.2)	.601 (15.3)	1.300 (33.0)	2.010 (51.1)	.710 (18.0)	1.370 (34.8)
18	1.000 - 20 UNEF	1.220 (31.0)	.722 (18.3)	1.360 (34.5)	2.170 (55.1)	.730 (18.5)	1.470 (37.3)
20	1.125 - 18 UNEF	1.350 (34.3)	.862 (21.9)	1.500 (38.1)	2.250 (57.2)	.740 (18.8)	1.510 (38.4)
22	1.250 - 18 UNEF	1.470 (37.3)	.970 (24.6)	1.620 (41.1)	2.250 (57.2)	.630 (16.0)	1.570 (39.9)
24	1.375 - 18 UNEF	1.590 (40.4)	1.082 (27.5)	1.680 (42.7)	2.330 (59.2)	.630 (16.0)	1.640 (41.7)
28	1.625 - 18 UNEF	1.970 (50.0)	1.241 (31.5)	1.710 (43.4)	2.330 (59.2)	.630 (16.0)	1.710 (43.4)

APPLICATION NOTES

1. Assembly identified with manufacturer's name and part number, space permitting.
2. For complete dimensions, see the applicable Military Specification.
3. Cable entry is defined as the accommodation range for the wire bundle or cable. Dimensions shown are not intended for inspection criteria.
4. Metric dimensions (mm) are in parentheses.

Dimensions in inches (millimeters) and are subject to change without notice.

M83723/59-1, M83723/60-1, MS27292 and MS27294 Threaded Protective Plug and Receptacle Covers



MIL-DTL-83723

MATING CONNECTOR
MIL-DTL-83723, Series III Threaded

Superseded Part Number

Basic Part Number
MS27292 = Plug Cover
MS27294 = Receptacle Cover

Dash Number
MS27292 - 1

See Note 3

Basic Part Number
M83723/59-1 = Plug Cover
M83723/60-1 = Receptacle Cover

Shell Size
10

Attachment Style
C = 5.0" (127.0) Chain
P = 8.0" (203.2) Chain
R = 5.0" (127.0) Rope
T = 8.0" (203.2) Rope
N = No Attachment

M83723/59-1 10 A C

Finish
A = Black Anodize
R = Electroless Nickel
W = Cadmium over Electroless Nickel

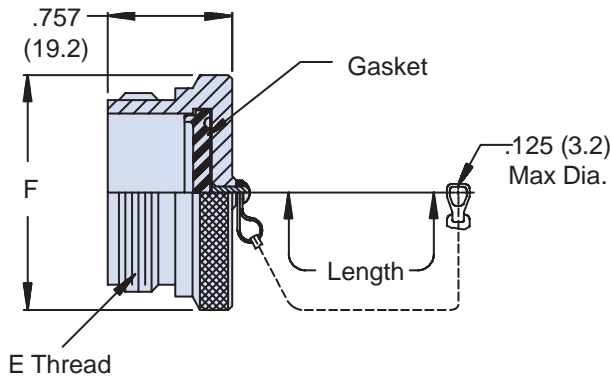

**M83723/59-1 PLUG COVER
M27292 PLUG COVER (SEE NOTE 3)**

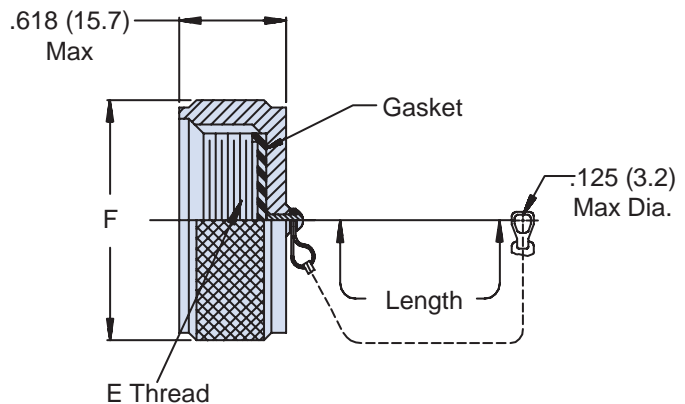

**M83723/60-1 RECEPTACLE COVER
M27294 RECEPTACLE COVER (SEE NOTE 3)**

TABLE I: Shell Size, Dash Number, Thread and Dimensions

Shell Size	M27292 M27294 Dash No.	E Thread Class 2A/2B	K Dia Max
8	7	9/16- 24 UNEF	.776 (19.7)
10	1	11/16- 24 UNEF	.906 (23.0)
12	2	7/8- 20 UNEF	1.078 (27.4)
14	3	15/16- 20 UNEF	1.141 (29.0)
16	4	1 1/16- 18 UNEF	1.266 (32.2)
18	5	1 3/16- 18 UNEF	1.375 (34.9)
20	8	1 5/16- 18 UNEF	1.510 (38.4)
22	6	1 7/16- 18 UNEF	1.625 (41.3)
24	9	1 9/16- 18 UNEF	1.760 (44.7)

- APPLICATION NOTES**
1. Assembly identified with manufacturer's name and part number, space permitting.
 2. For complete dimensions, see the applicable Military Specification.
 3. MS27292 and MS27294 have a black anodize finish. Dash numbers 1, 2 and 7 have a 3.0-inch (76.2) wire rope attachment. Other dash numbers have a 5-inch (127.0) wire rope attachment.
 4. Metric dimensions (mm) are in parentheses.

Dimensions in inches (millimeters) and are subject to change without notice.



M83723/59-2, M83723/60-2, MS27293 and MS29295
Protective Plug and Receptacle Covers
Bayonet Coupling

MATING CONNECTOR
MIL-DTL-83723 Bayonet

Attachment Style
C = 5.0" (127.0) Chain
P = 8.0" (203.2) Chain
R = 5.0" (127.0) Rope
T = 8.0" (203.2) Rope
N = No Attachment

Basic Part Number
M83723/59-2 = Plug Cover
M83723/60-2 = Receptacle Cover

Shell Size

M83723/59-2

10

A

C

Finish
A = Black Anodize
R = Electroless Nickel
W = Cadmium over Electroless Nickel

Superseded Part Number

Basic Part Number
MS27293 = Plug Cover
MS27295 = Receptacle Cover

Dash Number
1

MS27293 - 1

See Note 3

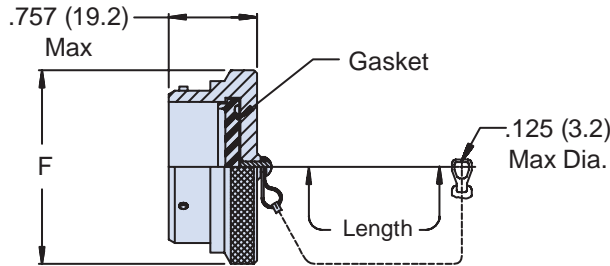

M83723/59-2 PLUG COVER
M27293 PLUG COVER (SEE NOTE 3)

TABLE I: Shell Size, Dash Number and Dimensions

Shell Size	M27292 M27294 Dash No.	F Dia Max
8	7	.776 (19.7)
10	1	.906 (23.0)
12	2	1.078 (27.4)
14	3	1.141 (29.0)
16	4	1.266 (32.2)
18	5	1.375 (34.9)
20	8	1.510 (38.4)
22	6	1.625 (41.3)
24	9	1.760 (44.7)

Dimensions in inches (millimeters) and are subject to change without notice.

M83723/70 Series III Quick-Disconnect Receptacle Adapter



MIL-DTL-83723

Basic Part Number

M83723/70

Dash No.

W 22

Material and Finish

- A = Aluminum, Black Anodize*
- R = Aluminum, Electroless Nickel*
- G = Corrosion-Resistant Steel Passivate*
- W = Aluminum, Cadmium Olive Drab over Electroless Nickel*

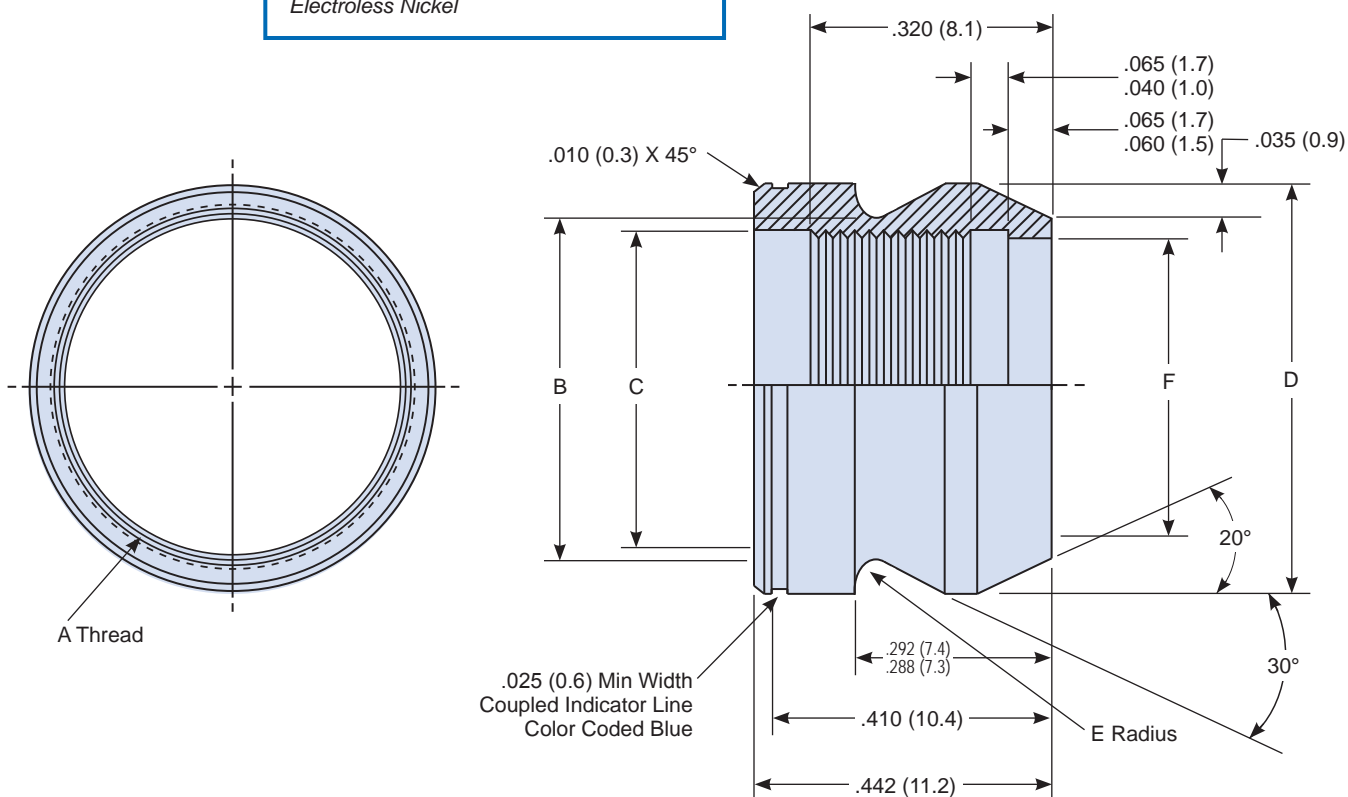

APPLICATION NOTES

1. Dimensions are in inches and apply after plating.
2. Metric equivalents are in parentheses and given for information only.
3. Unless otherwise specified, tolerances shall be $\pm .005$ (0.13) for three decimal places, $\pm .01$ (0.25) for two decimal places and $\pm 1/2^\circ$ for all angles.
4. Coupling indicator line shall be color coded blue and $.025 \pm .010$ (0.64 \pm 0.25) wide.

Dimensions in inches (millimeters) and are subject to change without notice.

© 2013 Glenair, Inc.

U.S. CAGE Code 06324

Printed in U.S.A.





M83723/70 Straight Adapter

TABLE I: Shell Size, Thread, Teeth and Dimensions

Shell Size	A Coupling Thread UNEF-2B	B Dia	C Dia	D Dia	E Radius	F Dia
8	.5625-24	.607 (15.42)	.579 (14.71)	.689 (17.50)	.036 (0.91)	.525 (13.34)
		.603 (15.32)	.575 (14.61)	.685 (17.40)	.031 (0.79)	
10	.6875-24	.732 (18.59)	.714 (18.14)	.814 (20.68)	.036 (0.91)	.650 (16.51)
		.728 (18.49)	.710 (18.03)	.810 (20.57)	.031 (0.79)	
12	.875-20	.918 (23.34)	.894 (22.71)	1.001 (25.43)	.036 (0.91)	.840 (21.34)
		.915 (23.24)	.890 (22.61)	.997 (25.32)	.031 (0.79)	
14	.9375-20	.982 (24.94)	.954 (24.23)	1.064 (27.03)	.036 (0.91)	.900 (22.86)
		.978 (24.84)	.950 (24.13)	1.060 (26.92)	.031 (0.79)	
16	1.0625-18	1.107 (28.12)	1.079 (27.41)	1.189 (30.20)	.036 (0.91)	1.025 (26.04)
		1.103 (28.02)	1.075 (27.31)	1.185 (30.10)	.031 (0.79)	
18	1.1875-18	1.232 (31.29)	1.204 (30.58)	1.330 (33.78)	.044 (1.12)	1.150 (29.21)
		1.228 (31.19)	1.200 (30.48)	1.326 (33.68)	.039 (0.99)	
20	1.3125-18	1.357 (34.47)	1.329 (33.76)	1.455 (36.96)	.044 (1.12)	1.275 (32.39)
		1.353 (34.37)	1.325 (33.66)	1.451 (36.86)	.039 (0.99)	
22	1.4375-18	1.482 (37.64)	1.454 (36.93)	1.580 (40.13)	.044 (1.12)	1.400 (35.56)
		1.478 (37.54)	1.450 (36.83)	1.576 (40.03)	.039 (0.99)	
24	1.5625-18	1.607 (40.82)	1.579 (40.11)	1.705 (43.31)	.044 (1.12)	1.525 (38.74)
		1.603 (40.72)	1.575 (40.01)	1.701 (43.21)	.039 (0.99)	

Dimensions in inches (millimeters) and are subject to change without notice.

AS81511 Qualified Backshells and Connector Accessories



SECTION F • AS81511 QUALIFIED PRODUCTS • SECTION F

Industry Specification Number	Part Identification Number	Military Part Number Superseded	Glenair Commercial Part Number	Description	Glenair Connector Designator/Interface	Page No.
AS81511/13	M81511/13	---	620JS001	Straight Non-Self-Locking Strain Relief	"J" AS81511 Series I, II, III & IV	F-2
AS81511/14	M81511/14 A M81511/14 B	---	390JS012 390JS012	Straight EMI/RFI Environmental Backshell A Straight EMI/RFI Environmental Backshell B	"J" AS81511 Series I, II, III & IV	F-3
AS81511/14	M81511/14 C M81511/14 D	---	380JS008 380JS008	Str. EMI/RFI Non-Environmental Backshell C Str. EMI/RFI Non-Environmental Backshell D	"J" AS81511 Series I, II, III & IV	F-5
AS81511/17 AS81511/18	M81511/17 M81511/18	---	660-017 660-018	Protective Plug Cover Protective Receptacle Cover	AS81511 Series I, II, III & IV	F-7
AS81511/19	M81511/19	---	650JS002	Dummy Storage Receptacle	AS81511 Series I, II, III & IV	F-8
AS81511/20	M81511/20	---	Consult Factory	Jam Nut	AS81511 Series I, II, III & IV	F-9
AS81511/29	M81511/29	---	660-016	Protective Plug Cover	AS81511 Series I, II, III & IV	F-7
AS81511/30	M81511/30	---	650JS001	Dummy Storage Receptacle Bayonet Coupling	MIL-DTL-26500 and MIL-DTL-83723, Series III	F-10

Dimensions in inches (millimeters) and are subject to change without notice.

CONNECTOR DESIGNATOR:

J AS81511 Series I, II, III & IV
Basic
Part Number

Shell Size

M81511/13**16****A1**

Adapter Connector Class Designator

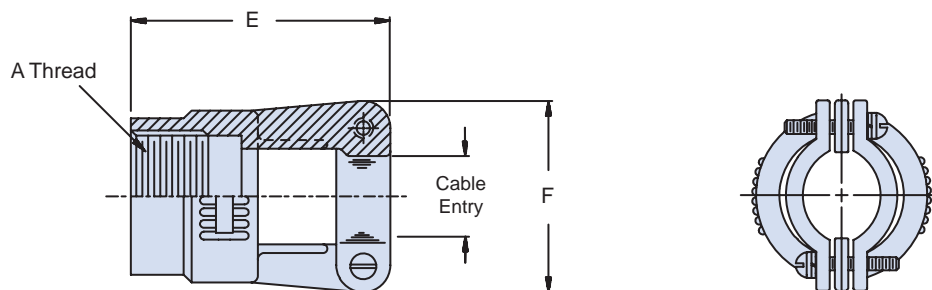
*A1 = Classes E, H, and P**B1 = Classes A, B, C, F, G, and T*
TABLE I: Shell Size, Cable Entry and Backshell Dimensions

Shell Size	A Thread Class 2B	E Max	F Max	Cable Entry			
				Min		Max	
08	.500 - 28 UNEF	1.375 (34.9)	.775 (19.7)	.062 (1.6)	.125 (3.2)	.062 (1.6)	.125 (3.2)
10	.625 - 28 UN	1.375 (34.9)	.955 (24.3)	.125 (3.2)	.250 (6.4)	.125 (3.2)	.250 (6.4)
14	.875 - 28 UN	1.375 (34.9)	1.145 (29.1)	.250 (6.4)	.500 (12.7)	.250 (6.4)	.500 (12.7)
16	1.000 - 28 UN	1.375 (34.9)	1.210 (30.7)	.375 (9.5)	.625 (15.9)	.375 (9.5)	.625 (15.9)
18	1.125 - 28 UN	1.375 (34.9)	1.330 (33.8)	.500 (12.7)	.750 (19.1)	.500 (12.7)	.750 (19.1)
20	1.250 - 28 UN	1.452 (36.9)	1.470 (37.3)	.625 (15.9)	.875 (22.2)	.625 (15.9)	.875 (22.2)
22	1.375 - 28 UN	1.452 (36.9)	1.580 (40.1)	.750 (19.1)	1.000 (25.4)	.750 (19.1)	1.000 (25.4)
24	1.500 - 28 UN	1.452 (36.9)	1.720 (43.7)	.750 (19.1)	1.125 (28.6)	.750 (19.1)	1.125 (28.6)

APPLICATION NOTES

1. Assembly to be identified with manufacturer's name and part number, space permitting.
2. Cable Entry is defined as the accommodation entry for the wire bundle or cable. Dimensions are not intended for inspection criteria.
3. For complete dimensions, see the applicable Military Specification.
4. Metric dimensions (mm) are in parentheses.

Dimensions in inches (millimeters) and are subject to change without notice.

AS81511/14 Straight EMI/RFI Environmental Backshell A & B



AS81511

CONNECTOR DESIGNATOR:

J AS81511 Series I, II, III & IV

Basic Part Number

Dash Number (Table I)

M81511/14 - 050

TABLE I: Dash Number and Dimensions

Dash No.	Shell Size	Function	A Thread Class 2B	Length Ref.	Cable Range	
					Min	Max
001	08	A	.500 - 28 UNEF	2.22 (56.4)	.062 (1.6)	.125 (3.2)
002	08	A	.500 - 28 UNEF	2.22 (56.4)	.125 (3.2)	.250 (6.4)
003	08	B	.500 - 28 UNEF	2.72 (69.1)	.062 (1.6)	.125 (3.2)
004	08	B	.500 - 28 UNEF	2.72 (69.1)	.125 (3.2)	.250 (6.4)
005	08	A	.500 - 28 UNEF	2.72 (69.1)	.062 (1.6)	.125 (3.2)
006	08	A	.500 - 28 UNEF	2.72 (69.1)	.125 (3.2)	.250 (6.4)
007	08	B	.500 - 28 UNEF	3.22 (81.8)	.062 (1.6)	.125 (3.2)
008	08	B	.500 - 28 UNEF	3.22 (81.8)	.125 (3.2)	.250 (6.4)
009	10	A	.625 - 28 UN	2.22 (56.4)	.125 (3.2)	.250 (6.4)
010	10	A	.625 - 28 UN	2.22 (56.4)	.250 (6.4)	.375 (9.5)
011	10	A	.625 - 28 UN	2.22 (56.4)	.375 (9.5)	.500 (12.7)
012	10	B	.625 - 28 UN	2.72 (69.1)	.125 (3.2)	.250 (6.4)
013	10	B	.625 - 28 UN	2.72 (69.1)	.250 (6.4)	.375 (9.5)
014	10	B	.625 - 28 UN	2.72 (69.1)	.375 (9.5)	.500 (12.7)
015	10	A	.625 - 28 UN	2.72 (69.1)	.125 (3.2)	.250 (6.4)
016	10	A	.625 - 28 UN	2.72 (69.1)	.250 (6.4)	.375 (9.5)
017	10	A	.625 - 28 UN	2.72 (69.1)	.375 (9.5)	.500 (12.7)
018	10	B	.625 - 28 UN	3.22 (81.8)	.125 (3.2)	.250 (6.4)
019	10	B	.625 - 28 UN	3.22 (81.8)	.250 (6.4)	.375 (9.5)
020	10	B	.625 - 28 UN	3.22 (81.8)	.375 (9.5)	.500 (12.7)
021	14	A	.875 - 28 UN	2.22 (56.4)	.250 (6.4)	.375 (9.5)
022	14	A	.875 - 28 UN	2.22 (56.4)	.375 (9.5)	.500 (12.7)
023	14	A	.875 - 28 UN	2.22 (56.4)	.500 (12.7)	.625 (15.9)
024	14	B	.875 - 28 UN	2.72 (69.1)	.250 (6.4)	.375 (9.5)
025	14	B	.875 - 28 UN	2.72 (69.1)	.375 (9.5)	.500 (12.7)
026	14	B	.875 - 28 UN	2.72 (69.1)	.500 (12.7)	.625 (15.9)
027	14	A	.875 - 28 UN	2.72 (69.1)	.250 (6.4)	.375 (9.5)
028	14	A	.875 - 28 UN	2.72 (69.1)	.375 (9.5)	.500 (12.7)
029	14	A	.875 - 28 UN	2.72 (69.1)	.500 (12.7)	.625 (15.9)
030	14	B	.875 - 28 UN	3.22 (81.8)	.250 (6.4)	.375 (9.5)
031	14	B	.875 - 28 UN	3.22 (81.8)	.375 (9.5)	.500 (12.7)
032	14	B	.875 - 28 UN	3.22 (81.8)	.500 (12.7)	.625 (15.9)
033	16	A	1.000 - 28 UN	2.22 (56.4)	.250 (6.4)	.375 (9.5)
034	16	A	1.000 - 28 UN	2.22 (56.4)	.375 (9.5)	.500 (12.7)
035	16	A	1.000 - 28 UN	2.22 (56.4)	.500 (12.7)	.625 (15.9)
036	16	B	1.000 - 28 UN	2.72 (69.1)	.250 (6.4)	.375 (9.5)
037	16	B	1.000 - 28 UN	2.72 (69.1)	.375 (9.5)	.500 (12.7)

Table I Continued on Page F-4

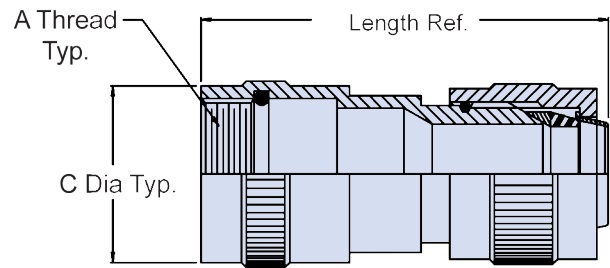

Function "A" Adapter Assembly

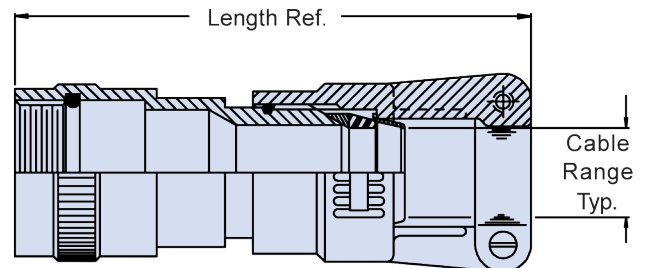

Function "B" Adapter Assembly

APPLICATION NOTES

1. For complete dimensions see the applicable Military Specification.
2. Metric dimensions (mm) are in parentheses.
3. Cable Range is defined as the accommodation range for the wire bundle or cable. Dimensions shown are not intended for inspection criteria.
4. For functions C and D see page F-5.

Dimensions in inches (millimeters) and are subject to change without notice.

© 2013 Glenair, Inc.

U.S. CAGE Code 06324

Printed in U.S.A.

TABLE I: Dash Number and Dimensions (Continued from Page F-3)

Dash No.	Shell Size	Function	A Thread Class 2B	C Dia Max	Length Ref.	Cable Range	
						Min	Max
038	16	B	1.000 - 28 UN	1.056 (26.8)	2.72 (69.1)	.500 (12.7)	.625 (15.9)
039	16	A	1.000 - 28 UN	1.056 (26.8)	2.72 (69.1)	.250 (6.4)	.375 (9.5)
040	16	A	1.000 - 28 UN	1.056 (26.8)	2.72 (69.1)	.375 (9.5)	.500 (12.7)
041	16	A	1.000 - 28 UN	1.056 (26.8)	2.72 (69.1)	.500 (12.7)	.625 (15.9)
042	16	B	1.000 - 28 UN	1.056 (26.8)	3.22 (81.8)	.250 (6.4)	.375 (9.5)
043	16	B	1.000 - 28 UN	1.056 (26.8)	3.22 (81.8)	.375 (9.5)	.500 (12.7)
044	16	B	1.000 - 28 UN	1.056 (26.8)	3.22 (81.8)	.500 (12.7)	.625 (15.9)
045	18	A	1.125 - 28 UN	1.180 (30.0)	2.22 (56.4)	.375 (9.5)	.500 (12.7)
046	18	A	1.125 - 28 UN	1.180 (30.0)	2.22 (56.4)	.500 (12.7)	.625 (15.9)
047	18	A	1.125 - 28 UN	1.180 (30.0)	2.22 (56.4)	.625 (15.9)	.750 (19.1)
048	18	B	1.125 - 28 UN	1.180 (30.0)	2.72 (69.1)	.375 (9.5)	.500 (12.7)
049	18	B	1.125 - 28 UN	1.180 (30.0)	2.72 (69.1)	.500 (12.7)	.625 (15.9)
050	18	B	1.125 - 28 UN	1.180 (30.0)	2.72 (69.1)	.625 (15.9)	.750 (19.1)
051	18	A	1.125 - 28 UN	1.180 (30.0)	2.72 (69.1)	.375 (9.5)	.500 (12.7)
052	18	A	1.125 - 28 UN	1.180 (30.0)	2.72 (69.1)	.500 (12.7)	.625 (15.9)
053	18	A	1.125 - 28 UN	1.180 (30.0)	2.72 (69.1)	.625 (15.9)	.750 (19.1)
054	18	B	1.125 - 28 UN	1.180 (30.0)	3.22 (81.8)	.375 (9.5)	.500 (12.7)
055	18	B	1.125 - 28 UN	1.180 (30.0)	3.22 (81.8)	.500 (12.7)	.625 (15.9)
056	18	B	1.125 - 28 UN	1.180 (30.0)	3.22 (81.8)	.625 (15.9)	.750 (19.1)
113	20	A	1.250 - 28 UN	1.305 (33.1)	2.30 (58.4)	.500 (12.7)	.625 (15.9)
114	20	A	1.250 - 28 UN	1.305 (33.1)	2.30 (58.4)	.625 (15.9)	.750 (19.1)
115	20	A	1.250 - 28 UN	1.305 (33.1)	2.30 (58.4)	.750 (19.1)	.875 (22.2)
116	20	B	1.250 - 28 UN	1.305 (33.1)	2.80 (71.1)	.500 (12.7)	.625 (15.9)
117	20	B	1.250 - 28 UN	1.305 (33.1)	2.80 (71.1)	.625 (15.9)	.750 (19.1)
118	20	B	1.250 - 28 UN	1.305 (33.1)	2.80 (71.1)	.750 (19.1)	.875 (22.2)
119	20	A	1.250 - 28 UN	1.305 (33.1)	2.80 (71.1)	.500 (12.7)	.625 (15.9)
120	20	A	1.250 - 28 UN	1.305 (33.1)	2.80 (71.1)	.625 (15.9)	.750 (19.1)
121	20	A	1.250 - 28 UN	1.305 (33.1)	2.80 (71.1)	.750 (19.1)	.875 (22.2)
122	20	B	1.250 - 28 UN	1.305 (33.1)	3.30 (83.8)	.500 (12.7)	.625 (15.9)
123	20	B	1.250 - 28 UN	1.305 (33.1)	3.30 (83.8)	.625 (15.9)	.750 (19.1)
124	20	B	1.250 - 28 UN	1.305 (33.1)	3.30 (83.8)	.750 (19.1)	.875 (22.2)
125	22	A	1.375 - 28 UN	1.430 (36.3)	2.30 (58.4)	.625 (15.9)	.750 (19.1)
126	22	A	1.375 - 28 UN	1.430 (36.3)	2.30 (58.4)	.750 (19.1)	.875 (22.2)
127	22	A	1.375 - 28 UN	1.430 (36.3)	2.30 (58.4)	.875 (22.2)	1.000 (25.4)
128	22	B	1.375 - 28 UN	1.430 (36.3)	2.80 (71.1)	.625 (15.9)	.750 (19.1)
129	22	B	1.375 - 28 UN	1.430 (36.3)	2.80 (71.1)	.750 (19.1)	.875 (22.2)
130	22	B	1.375 - 28 UN	1.430 (36.3)	2.80 (71.1)	.875 (22.2)	1.000 (25.4)
131	22	A	1.375 - 28 UN	1.430 (36.3)	2.80 (71.1)	.625 (15.9)	.750 (19.1)
132	22	A	1.375 - 28 UN	1.430 (36.3)	2.80 (71.1)	.750 (19.1)	.875 (22.2)
133	22	A	1.375 - 28 UN	1.430 (36.3)	2.80 (71.1)	.875 (22.2)	1.000 (25.4)
134	22	B	1.375 - 28 UN	1.430 (36.3)	3.30 (83.8)	.625 (15.9)	.750 (19.1)
135	22	B	1.375 - 28 UN	1.430 (36.3)	3.30 (83.8)	.750 (19.1)	.875 (22.2)
136	22	B	1.375 - 28 UN	1.430 (36.3)	3.30 (83.8)	.875 (22.2)	1.000 (25.4)
137	24	A	1.500 - 28 UN	1.555 (39.5)	2.30 (58.4)	.750 (19.1)	.875 (22.2)
138	24	A	1.500 - 28 UN	1.555 (39.5)	2.30 (58.4)	.875 (22.2)	1.000 (25.4)
139	24	A	1.500 - 28 UN	1.555 (39.5)	2.30 (58.4)	1.000 (25.4)	1.125 (28.6)
140	24	B	1.500 - 28 UN	1.555 (39.5)	2.80 (71.1)	.750 (19.1)	.875 (22.2)
141	24	B	1.500 - 28 UN	1.555 (39.5)	2.80 (71.1)	.875 (22.2)	1.000 (25.4)
142	24	B	1.500 - 28 UN	1.555 (39.5)	2.80 (71.1)	1.000 (25.4)	1.125 (28.6)
143	24	A	1.500 - 28 UN	1.555 (39.5)	2.80 (71.1)	.750 (19.1)	.875 (22.2)
144	24	A	1.500 - 28 UN	1.555 (39.5)	2.80 (71.1)	.875 (22.2)	1.000 (25.4)
145	24	A	1.500 - 28 UN	1.555 (39.5)	2.80 (71.1)	1.000 (25.4)	1.125 (28.6)
146	24	B	1.500 - 28 UN	1.555 (39.5)	3.30 (83.8)	.750 (19.1)	.875 (22.2)
147	24	B	1.500 - 28 UN	1.555 (39.5)	3.30 (83.8)	.875 (22.2)	1.000 (25.4)
148	24	B	1.500 - 28 UN	1.555 (39.5)	3.30 (83.8)	1.000 (25.4)	1.125 (28.6)

Dimensions in inches (millimeters) and are subject to change without notice.

AS81511/14 Functions C and D Straight EMI/RFI Non-Environmental Backshell



AS81511

CONNECTOR DESIGNATOR:

J AS81511 Series I, II, III & IV

Basic Part Number

Dash Number (Table I)

M81511/14

100

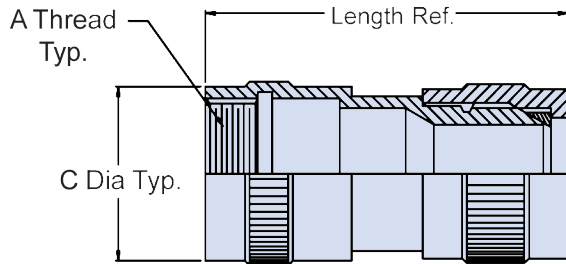

Function "C" Adapter Assembly

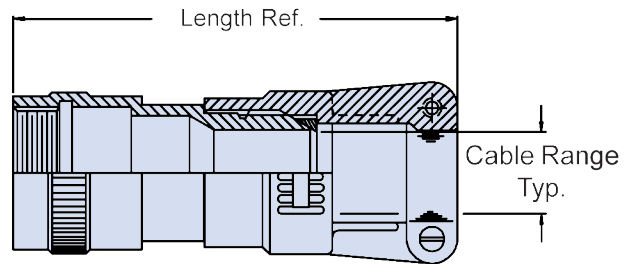

Function "D" Adapter Assembly

TABLE I: Dash Number and Dimensions							
Dash No.	Shell Size	Function	A Thread Class 2B	C Dia Max	Length Ref.	Cable Range	
						Min	Max
057	08	C	.500 - 28 UNEF	.555 (14.1)	1.71 (43.4)	.062 (1.6)	.125 (3.2)
058	08	C	.500 - 28 UNEF	.555 (14.1)	1.71 (43.4)	.125 (3.2)	.250 (6.4)
059	08	D	.500 - 28 UNEF	.555 (14.1)	2.47 (62.7)	.062 (1.6)	.125 (3.2)
060	08	D	.500 - 28 UNEF	.555 (14.1)	2.47 (62.7)	.125 (3.2)	.250 (6.4)
061	08	C	.500 - 28 UNEF	.555 (14.1)	2.21 (56.1)	.062 (1.6)	.125 (3.2)
062	08	C	.500 - 28 UNEF	.555 (14.1)	2.21 (56.1)	.125 (3.2)	.250 (6.4)
063	08	D	.500 - 28 UNEF	.555 (14.1)	2.97 (75.4)	.062 (1.6)	.125 (3.2)
064	08	D	.500 - 28 UNEF	.555 (14.1)	2.97 (75.4)	.125 (3.2)	.250 (6.4)
065	10	C	.625 - 28 UN	.680 (17.3)	1.71 (43.4)	.125 (3.2)	.250 (6.4)
066	10	C	.625 - 28 UN	.680 (17.3)	1.71 (43.4)	.250 (6.4)	.375 (9.5)
067	10	C	.625 - 28 UN	.680 (17.3)	1.71 (43.4)	.375 (9.5)	.500 (12.7)
068	10	D	.625 - 28 UN	.680 (17.3)	2.47 (62.7)	.125 (3.2)	.250 (6.4)
069	10	D	.625 - 28 UN	.680 (17.3)	2.47 (62.7)	.250 (6.4)	.375 (9.5)
070	10	D	.625 - 28 UN	.680 (17.3)	2.47 (62.7)	.375 (9.5)	.500 (12.7)
071	10	C	.625 - 28 UN	.680 (17.3)	2.21 (56.1)	.125 (3.2)	.250 (6.4)
072	10	C	.625 - 28 UN	.680 (17.3)	2.21 (56.1)	.250 (6.4)	.375 (9.5)
073	10	C	.625 - 28 UN	.680 (17.3)	2.21 (56.1)	.375 (9.5)	.500 (12.7)
074	10	D	.625 - 28 UN	.680 (17.3)	2.97 (75.4)	.125 (3.2)	.250 (6.4)
075	10	D	.625 - 28 UN	.680 (17.3)	2.97 (75.4)	.250 (6.4)	.375 (9.5)
076	10	D	.625 - 28 UN	.680 (17.3)	2.97 (75.4)	.375 (9.5)	.500 (12.7)
077	14	C	.875 - 28 UN	.930 (23.6)	1.71 (43.4)	.250 (6.4)	.375 (9.5)
078	14	C	.875 - 28 UN	.930 (23.6)	1.71 (43.4)	.375 (9.5)	.500 (12.7)
079	14	C	.875 - 28 UN	.930 (23.6)	1.71 (43.4)	.500 (12.7)	.625 (15.9)
080	14	D	.875 - 28 UN	.930 (23.6)	2.47 (62.7)	.250 (6.4)	.375 (9.5)
081	14	D	.875 - 28 UN	.930 (23.6)	2.47 (62.7)	.375 (9.5)	.500 (12.7)
082	14	D	.875 - 28 UN	.930 (23.6)	2.47 (62.7)	.500 (12.7)	.625 (15.9)
083	14	C	.875 - 28 UN	.930 (23.6)	2.21 (56.1)	.250 (6.4)	.375 (9.5)
084	14	C	.875 - 28 UN	.930 (23.6)	2.21 (56.1)	.375 (9.5)	.500 (12.7)
085	14	C	.875 - 28 UN	.930 (23.6)	2.21 (56.1)	.500 (12.7)	.625 (15.9)
086	14	D	.875 - 28 UN	.930 (23.6)	2.97 (75.4)	.250 (6.4)	.375 (9.5)
087	14	D	.875 - 28 UN	.930 (23.6)	2.97 (75.4)	.375 (9.5)	.500 (12.7)
088	14	D	.875 - 28 UN	.930 (23.6)	2.97 (75.4)	.500 (12.7)	.625 (15.9)

Table I Continued on Next Column (Right)

TABLE I: Dash Number and Dimensions (Continued)							
Dash No.	Shell Size	Function	A Thread Class 2B	C Dia Max	Length Ref.	Cable Range	
						Min	Max
089	16	C	1.000 - 28 UN	1.056 (26.8)	1.71 (43.4)	.250 (6.4)	.375 (9.5)
090	16	C	1.000 - 28 UN	1.056 (26.8)	1.71 (43.4)	.375 (9.5)	.500 (12.7)
091	16	C	1.000 - 28 UN	1.056 (26.8)	1.71 (43.4)	.500 (12.7)	.625 (15.9)
092	16	D	1.000 - 28 UN	1.056 (26.8)	2.47 (62.7)	.250 (6.4)	.375 (9.5)
093	16	D	1.000 - 28 UN	1.056 (26.8)	2.47 (62.7)	.375 (9.5)	.500 (12.7)
094	16	D	1.000 - 28 UN	1.056 (26.8)	2.47 (62.7)	.500 (12.7)	.625 (15.9)
095	16	C	1.000 - 28 UN	1.056 (26.8)	2.21 (56.1)	.250 (6.4)	.375 (9.5)
096	16	C	1.000 - 28 UN	1.056 (26.8)	2.21 (56.1)	.375 (9.5)	.500 (12.7)
097	16	C	1.000 - 28 UN	1.056 (26.8)	2.21 (56.1)	.500 (12.7)	.625 (15.9)
098	16	D	1.000 - 28 UN	1.056 (26.8)	2.97 (75.4)	.250 (6.4)	.375 (9.5)
099	16	D	1.000 - 28 UN	1.056 (26.8)	2.97 (75.4)	.375 (9.5)	.500 (12.7)
100	16	D	1.000 - 28 UN	1.056 (26.8)	2.97 (75.4)	.500 (12.7)	.625 (15.9)
101	18	C	1.125 - 28 UN	1.180 (30.0)	1.71 (43.4)	.375 (9.5)	.500 (12.7)
102	18	C	1.125 - 28 UN	1.180 (30.0)	1.71 (43.4)	.500 (12.7)	.625 (15.9)
103	18	C	1.125 - 28 UN	1.180 (30.0)	1.71 (43.4)	.625 (15.9)	.750 (19.1)
104	18	D	1.125 - 28 UN	1.180 (30.0)	2.47 (62.7)	.375 (9.5)	.500 (12.7)
105	18	D	1.125 - 28 UN	1.180 (30.0)	2.47 (62.7)	.500 (12.7)	.625 (15.9)
106	18	D	1.125 - 28 UN	1.180 (30.0)	2.47 (62.7)	.625 (15.9)	.750 (19.1)
107	18	C	1.125 - 28 UN	1.180 (30.0)	2.21 (56.1)	.375 (9.5)	.500 (12.7)
108	18	C	1.125 - 28 UN	1.180 (30.0)	2.21 (56.1)	.500 (12.7)	.625 (15.9)
109	18	C	1.125 - 28 UN	1.180 (30.0)	2.21 (56.1)	.625 (15.9)	.750 (19.1)
110	18	D	1.125 - 28 UN	1.180 (30.0)	2.97 (75.4)	.375 (9.5)	.500 (12.7)
111	18	D	1.125 - 28 UN	1.180 (30.0)	2.97 (75.4)	.500 (12.7)	.625 (15.9)
112	18	D	1.125 - 28 UN	1.180 (30.0)	2.97 (75.4)	.625 (15.9)	.750 (19.1)
149	20	C	1.250 - 28 UN	1.305 (33.1)	1.78 (45.2)	.500 (12.7)	.625 (15.9)
150	20	C	1.250 - 28 UN	1.305 (33.1)	1.78 (45.2)	.625 (15.9)	.750 (19.1)
151	20	C	1.250 - 28 UN	1.305 (33.1)	1.78 (45.2)	.750 (19.1)	.875 (22.2)
152	20	D	1.250 - 28 UN	1.305 (33.1)	2.55 (64.8)	.500 (12.7)	.625 (15.9)
153	20	D	1.250 - 28 UN	1.305 (33.1)	2.55 (64.8)	.625 (15.9)	.750 (19.1)
154	20	D	1.250 - 28 UN	1.305 (33.1)	2.55 (64.8)	.750 (19.1)	.875 (22.2)
155	20	C	1.250 - 28 UN	1.305 (33.1)	2.28 (57.9)	.500 (12.7)	.625 (15.9)
156	20	C	1.250 - 28 UN	1.305 (33.1)	2.28 (57.9)	.625 (15.9)	.750 (19.1)

Table I Continued on Page F-6

Dimensions in inches (millimeters) and are subject to change without notice.



AS81511/14 Functions C and D Straight EMI/RFI Non-Environmental Backshell

TABLE I: Dash Number and Dimensions (Continued from Page F-5)

Dash No.	Shell Size	Function	A Thread Class 2B	C Dia Max	Length Ref.	Cable Range	
						Min	Max
157	20	C	1.250 - 28 UN	1.305 (33.1)	2.28 (57.9)	.750 (19.1)	.875 (22.2)
158	20	D	1.250 - 28 UN	1.305 (33.1)	3.05 (77.5)	.500 (12.7)	.625 (15.9)
159	20	D	1.250 - 28 UN	1.305 (33.1)	3.05 (77.5)	.625 (15.9)	.750 (19.1)
160	20	D	1.250 - 28 UN	1.305 (33.1)	3.05 (77.5)	.750 (19.1)	.875 (22.2)
161	22	C	1.375 - 28 UN	1.430 (36.3)	1.78 (45.2)	.625 (15.9)	.750 (19.1)
162	22	C	1.375 - 28 UN	1.430 (36.3)	1.78 (45.2)	.750 (19.1)	.875 (22.2)
163	22	C	1.375 - 28 UN	1.430 (36.3)	1.78 (45.2)	.875 (22.2)	1.000 (25.4)
164	22	D	1.375 - 28 UN	1.430 (36.3)	2.55 (64.8)	.625 (15.9)	.750 (19.1)
165	22	D	1.375 - 28 UN	1.430 (36.3)	2.55 (64.8)	.750 (19.1)	.875 (22.2)
166	22	D	1.375 - 28 UN	1.430 (36.3)	2.55 (64.8)	.875 (22.2)	1.000 (25.4)
167	22	C	1.375 - 28 UN	1.430 (36.3)	2.28 (57.9)	.625 (15.9)	.750 (19.1)
168	22	C	1.375 - 28 UN	1.430 (36.3)	2.28 (57.9)	.750 (19.1)	.875 (22.2)
169	22	C	1.375 - 28 UN	1.430 (36.3)	2.28 (57.9)	.875 (22.2)	1.000 (25.4)
170	22	D	1.375 - 28 UN	1.430 (36.3)	3.05 (77.5)	.625 (15.9)	.750 (19.1)
171	22	D	1.375 - 28 UN	1.430 (36.3)	3.05 (77.5)	.750 (19.1)	.875 (22.2)
172	22	D	1.375 - 28 UN	1.430 (36.3)	3.05 (77.5)	.875 (22.2)	1.000 (25.4)
173	24	C	1.500 - 28 UN	1.555 (39.5)	1.78 (45.2)	.750 (19.1)	.875 (22.2)
174	24	C	1.500 - 28 UN	1.555 (39.5)	1.78 (45.2)	.875 (22.2)	1.000 (25.4)
175	24	C	1.500 - 28 UN	1.555 (39.5)	1.78 (45.2)	1.000 (25.4)	1.125 (28.6)
176	24	D	1.500 - 28 UN	1.555 (39.5)	2.55 (64.8)	.750 (19.1)	.875 (22.2)
177	24	D	1.500 - 28 UN	1.555 (39.5)	2.55 (64.8)	.875 (22.2)	1.000 (25.4)
178	24	D	1.500 - 28 UN	1.555 (39.5)	2.55 (64.8)	1.000 (25.4)	1.125 (28.6)
179	24	C	1.500 - 28 UN	1.555 (39.5)	2.28 (57.9)	.750 (19.1)	.875 (22.2)
180	24	C	1.500 - 28 UN	1.555 (39.5)	2.28 (57.9)	.875 (22.2)	1.000 (25.4)
181	24	C	1.500 - 28 UN	1.555 (39.5)	2.28 (57.9)	1.000 (25.4)	1.125 (28.6)
182	24	D	1.500 - 28 UN	1.555 (39.5)	3.05 (77.5)	.750 (19.1)	.875 (22.2)
183	24	D	1.500 - 28 UN	1.555 (39.5)	3.05 (77.5)	.875 (22.2)	1.000 (25.4)
184	24	D	1.500 - 28 UN	1.555 (39.5)	3.05 (77.5)	1.000 (25.4)	1.125 (28.6)
171	22	D	1.375 - 28 UN	1.430 (36.3)	3.05 (77.5)	.750 (19.1)	.875 (22.2)
172	22	D	1.375 - 28 UN	1.430 (36.3)	3.05 (77.5)	.875 (22.2)	1.000 (25.4)
173	24	C	1.500 - 28 UN	1.555 (39.5)	1.78 (45.2)	.750 (19.1)	.875 (22.2)
174	24	C	1.500 - 28 UN	1.555 (39.5)	1.78 (45.2)	.875 (22.2)	1.000 (25.4)
175	24	C	1.500 - 28 UN	1.555 (39.5)	1.78 (45.2)	1.000 (25.4)	1.125 (28.6)
176	24	D	1.500 - 28 UN	1.555 (39.5)	2.55 (64.8)	.750 (19.1)	.875 (22.2)
177	24	D	1.500 - 28 UN	1.555 (39.5)	2.55 (64.8)	.875 (22.2)	1.000 (25.4)
178	24	D	1.500 - 28 UN	1.555 (39.5)	2.55 (64.8)	1.000 (25.4)	1.125 (28.6)
179	24	C	1.500 - 28 UN	1.555 (39.5)	2.28 (57.9)	.750 (19.1)	.875 (22.2)
180	24	C	1.500 - 28 UN	1.555 (39.5)	2.28 (57.9)	.875 (22.2)	1.000 (25.4)
181	24	C	1.500 - 28 UN	1.555 (39.5)	2.28 (57.9)	1.000 (25.4)	1.125 (28.6)
182	24	D	1.500 - 28 UN	1.555 (39.5)	3.05 (77.5)	.750 (19.1)	.875 (22.2)
183	24	D	1.500 - 28 UN	1.555 (39.5)	3.05 (77.5)	.875 (22.2)	1.000 (25.4)
184	24	D	1.500 - 28 UN	1.555 (39.5)	3.05 (77.5)	1.000 (25.4)	1.125 (28.6)

APPLICATION NOTES

1. For complete dimensions see the applicable Military Specification.
2. Metric dimensions (mm) are in parentheses.
3. Cable Range is defined as the accommodation range for the wire bundle or cable. Dimensions shown are not intended for inspection criteria.
4. For functions A and B see page F-3.

Dimensions in inches (millimeters) and are subject to change without notice.

AS81511/17, AS81511/18 and AS81511/29 Protective Plug and Receptacle Covers



AS81511

MATING CONNECTOR
AS81511

Basic Part Number
M81511/17 = Plug Cover Series 2
M81511/18 = Receptacle Cover Series 1 and 2
M81511/29 = Plug Cover Series 1

M81511/17 - 16

Shell Size

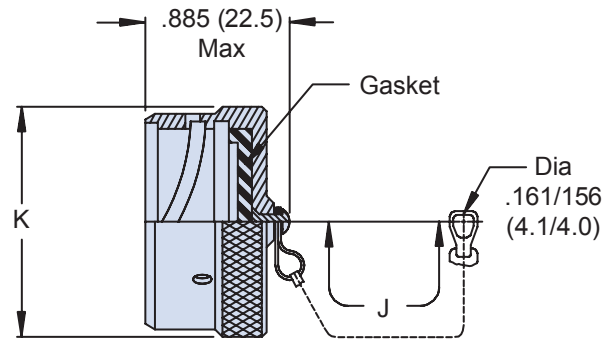
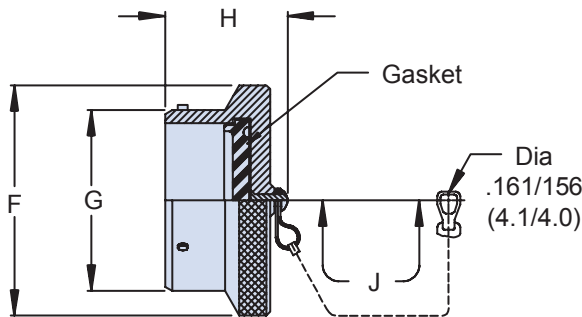

M81511/29 Plug Cover - Series 1
M81511/17 Plug Cover - Series 2

M81511/18 Receptacle Cover
Series 1 and 2

TABLE I: Shell Size, Attachment and Dimensions						
Shell Size	F Dia Max	G Dia +.000(0.0) -.006(0.2)	H Max		J ± One Link	K Dia Max
			M81511/29	M81511/17		
08	.845 (21.5)	.553 (14.0)	1.125 (28.6)	.985 (25.0)	3.0 (76.2)	.844 (21.4)
10	.970 (24.6)	.678 (17.2)	1.125 (28.6)	.985 (25.0)	3.0 (76.2)	.969 (24.6)
14	1.220 (31.0)	.928 (23.6)	1.125 (28.6)	.985 (25.0)	3.5 (88.9)	1.219 (31.0)
16	1.345 (34.2)	1.054 (26.8)	1.125 (28.6)	.985 (25.0)	3.5 (88.9)	1.345 (34.2)
18	1.470 (37.3)	1.178 (29.9)	1.125 (28.6)	.985 (25.0)	3.5 (88.9)	1.469 (37.3)
20*	1.595 (40.5)	1.303 (33.1)	1.125 (28.6)	—	3.5 (88.9)	1.594 (40.5)
22*	1.720 (43.7)	1.428 (36.3)	1.125 (28.6)	—	3.5 (88.9)	1.719 (43.7)
24*	1.845 (46.9)	1.553 (39.4)	1.125 (28.6)	—	3.5 (88.9)	1.844 (46.8)

* Not Applicable for M81511/17 or M81511/18

APPLICATION NOTES
1. Assembly identified with manufacturer's name and part number, space permitting.
2. For complete dimensions, see the applicable Military Specification.
3. Metric dimensions (mm) are in parentheses.

Dimensions in inches (millimeters) and are subject to change without notice.

© 2013 Glenair, Inc.

Mil-Spec Backshells

U.S. CAGE Code 06324

Rev. 8.29.14

Printed in U.S.A.

F

MATING CONNECTOR

AS81511 Series 2

**Basic
Part No.**
Finish:

 1 = Cadmium Olive Drab
 2 = Dull Chromium over Nickel

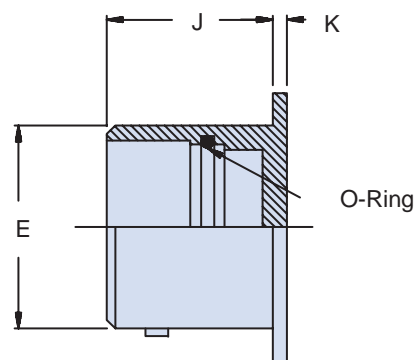
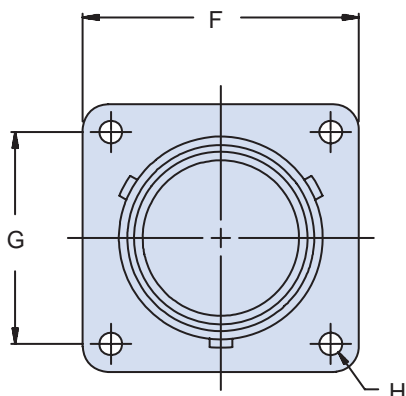
M81511/19 - 14 1
Shell Size

**TABLE I: Dash Number, Cable Entry
and Backshell Dimensions**

Shell Size	Ø E		F Sq.		G Sq.		H		J		K	
	±.003	(.1)	±.008	(.2)	±.005	(.1)	±.005	(0.1)	±.010	(.3)	±.005	(.1)
08	.550	(14.0)	.812	(20.6)	.594	(15.1)	.121	(3.1)	.645	(16.4)	.070	(1.8)
10	.675	(17.1)	.937	(23.8)	.719	(18.3)	.121	(3.1)	.645	(16.4)	.070	(1.8)
14	.925	(23.5)	1.125	(28.6)	.906	(23.0)	.121	(3.1)	.645	(16.4)	.070	(1.8)
16	1.051	(26.7)	1.250	(31.8)	.969	(24.6)	.121	(3.1)	.645	(16.4)	.070	(1.8)
18	1.175	(29.8)	1.343	(34.1)	1.062	(27.0)	.121	(3.1)	.645	(16.4)	.070	(1.8)

APPLICATION NOTES

1. Assembly to be identified with manufacturer's name and part number, space permitting.
2. For complete dimensions, see the applicable Military Specification.
3. Metric dimensions (mm) are in parentheses.

Dimensions in inches (millimeters) and are subject to change without notice.

AS81511/20 Jam Nut



AS81511

**MATING
CONNECTOR**

AS81511

M81511/20

8

1

**Basic
Part Number**

**Shell Size
Table I**

Material / Finish

- 1 = 150°C Maximum Temperature, Aluminum Material / Cadmium, Olive Drab over Electroless Nickel
- 2 = 175°C-200°C Temperature Range, Aluminum Material / Electroless Nickel, Grade A

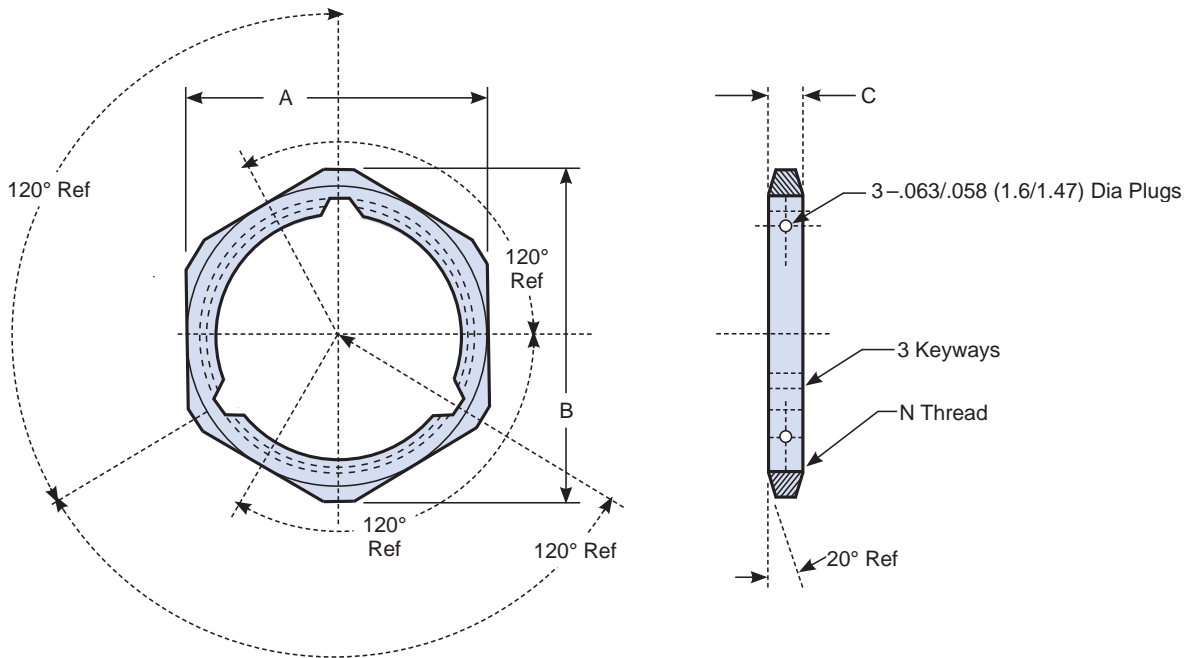

TABLE I: Reference for Connector Shell Size

Part No.	Tem Rating (C)	Shell Size (Ref)	A Across Flats	B	C	N Thread	Weight (Pounds) (Ref)
M81511 20-08-1	150°	8	.882 (22.40)	.977 (24.82)	.140 (3.56)	5-8-20UN-2B	.0038
M81511 20-08-2	175-200°	8	.870 (22.10)	.960 (24.38)	.125 (3.18)	5-8-20UN-2B	.0038
M81511 20-10-1	150°	10	.944 (23.98)	1.084 (27.53)	.140 (3.56)	3-4-20UNEF-2B	.0044
M81511 20-10-2	175-200°	10	.932 (23.67)	1.067 (27.10)	.125 (3.18)	3-4-20UNEF-2B	.0044
M81511 20-14-1	150°	14	1.194 (30.33)	1.373 (34.87)	.140 (3.56)	1-20UNEF-2B	.0057
M81511 20-14-2	175-200°	14	1.182 (30.02)	1.356 (34.44)	.125 (3.18)	1-20UNEF-2B	.0057
M81511 20-16-1	150°	16	1.319 (33.50)	1.517 (38.53)	.140 (3.56)	1-1-8-20UN-2B	.0071
M81511 20-16-2	175-200°	16	1.307 (33.20)	1.500 (38.10)	.125 (3.18)	1-1-8-20UN-2B	.0071
M81511 20-18-1	150°	18	1.444 (36.68)	1.662 (42.21)	.140 (3.56)	1-1-4-20UN-2B	.0079
M81511 20-18-2	175-200°	18	1.432 (36.37)	1.645 (41.78)	.125 (3.18)	1-1-4-20UN-2B	.0079
M81511 20-20-1	150°	20	1.632 (41.45)	1.772 (45.01)	.140 (3.56)	1-3-8-20UN-2B	.0091
M81511 20-20-2	175-200°	20	1.620 (41.15)	1.755 (44.58)	.125 (3.18)	1-3-8-20UN-2B	.0091
M81511 20-22-1	150°	22	1.694 (43.03)	1.950 (49.53)	.140 (3.56)	1-1-2-20UN-2B	.0102
M81511 20-22-2	175-200°	22	1.682 (42.72)	1.933 (49.10)	.125 (3.18)	1-1-2-20UN-2B	.0102
M81511 20-24-1	150°	24	1.882 (47.80)	2.086 (52.98)	.140 (3.56)	1-5-8-20UN-2B	.0123
M81511 20-24-2	175-200°	24	1.870 (47.50)	2.065 (52.45)	.125 (3.18)	1-5-8-20UN-2B	.0123

APPLICATION NOTES

1. The nut is aluminum, plugs are polytetrafluoroethylene.
2. This nut is used with MIL-C-81511 '3, '4, '23, '24, '27, '28, '32 and '37 receptacles.
3. Dimensions apply after plating.
4. For complete dimensions, see the applicable Military Specification.
5. Metric dimensions (mm) are in parentheses.

Dimensions in inches (millimeters) and are subject to change without notice.

F

MATING CONNECTOR

AS81511 Series 1

**Basic
Part No.**
Finish:

 1 = Cadmium Olive Drab
 2 = Dull Chromium over Nickel

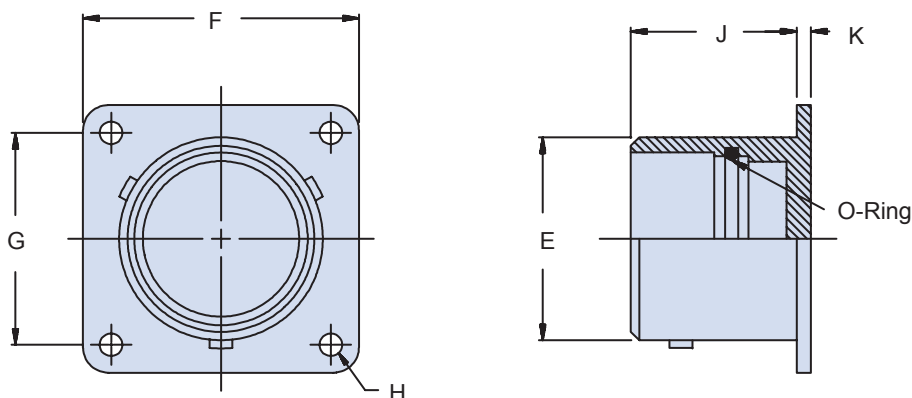
M81511/30 - 14 1
Shell Size

**TABLE I: Dash Number, Cable Entry
and Backshell Dimensions**

Shell Size	Ø E		F Sq.		G Sq.		H		J		K	
	±.003	(.1)	±.008	(.2)	±.005	(.1)	±.005	(0.1)	±.010	(.3)	±.005	(.1)
08	.550	(14.0)	.812	(20.6)	.594	(15.1)	.121	(3.1)	.645	(16.4)	.070	(1.8)
10	.675	(17.1)	.937	(23.8)	.719	(18.3)	.121	(3.1)	.645	(16.4)	.070	(1.8)
14	.925	(23.5)	1.125	(28.6)	.906	(23.0)	.121	(3.1)	.645	(16.4)	.070	(1.8)
16	1.051	(26.7)	1.250	(31.8)	.969	(24.6)	.121	(3.1)	.645	(16.4)	.070	(1.8)
18	1.175	(29.8)	1.343	(34.1)	1.062	(27.0)	.121	(3.1)	.645	(16.4)	.070	(1.8)
20	1.300	(33.0)	1.467	(37.3)	1.156	(29.4)	.121	(3.1)	.645	(16.4)	.070	(1.8)
22	1.425	(36.2)	1.562	(39.7)	1.250	(31.8)	.121	(3.1)	.645	(16.4)	.070	(1.8)
24	1.550	(39.4)	1.703	(43.3)	1.375	(34.9)	.148	(3.8)	.645	(16.4)	.070	(1.8)

APPLICATION NOTES

1. Assembly to be identified with manufacturer's name and part number, space permitting.
2. For complete dimensions, see the applicable Military Specification.
3. Metric dimensions (mm) are in parentheses.

Dimensions in inches (millimeters) and are subject to change without notice.

Miscellaneous Qualified Backshells and Connector Accessories



Industry Specification Number	Part Identification Number	Military Part Number Superseded	Glenair Commercial Part Number	Description	Glenair Connector Designator/Interface	Page No.
AS25042 AS25043	MS25042 MS25043	MS25042 MS25043	660-004 660-005	Threaded Protective Plug Cover Threaded Protective Receptacle Cover	AS50151	G-2
MS17349 MS17350	MS17349 MS17350	—	660-007 660-006	Threaded Protective Receptacle Cover Threaded Protective Plug Cover	MIL-DTL-22992	G-3
MS27291	MS27291	—	620ES050	Straight Non-Self-Locking Strain Relief	"E" MIL-DTL-26500	G-4
MIL-DTL-26500	MS27558	—	G2221-A	90° Non-Self-Locking Strain Relief	"E" MIL-DTL-26500	G-5
MIL-DTL-26500	MS27559	—	G2221-B	90° Non-Self-Locking Strain Relief	"E" MIL-DTL-26500	G-6
—	MS27741	—	410-003	TAG® Ring for Reliable Terminations	—	G-7
AS50151	MS3105	—	650BS001	Dummy Storage Receptacle, Threaded Coupling	AS50151	G-8
—	MS3115	—	650DS001	Dummy Storage Receptacle, Bayonet Coupling	MIL-DTL-26482	G-9
—	MS3180 MS3181	—	660-008 660-009	Protective Plug Cover, Bayonet Coupling Protective Receptacle Cover, Bayonet Coupling	MIL-DTL-26482	G-10
—	MS27512	MS3186	Consult Factory	Jam Nut with Safety Wire Holes	AS50151; MIL-DTL-26482; MIL-DTL-26500; MIL-DTL-83723 Series I; MIL-DTL-83723, Series III MIL-DTL-38999 Series I; MIL-DTL38999 Series II; MIL-DTL-28840; MIL-DTL-27599	G-11
—	M29504/04	—	Consult Factory	Fiber Optic Pin Terminus, Size 16	MIL-DTL-29504	G-13
—	M29504/05	—	Consult Factory	Fiber Optic Socket Terminus, Size 16	MIL-DTL-29504	G-14
MIL-DTL-83513/05	M83513/05	—	Consult Factory	Micro-D Jackscrew Kits	MIL-DTL-83513/05	G-15
MIL-DTL-83538/9	M83538/9S	—	Consult Factory	Straight Adapter and Extender	MIL-DTL-83538/4	G-16
MIL-S-81824/1	M81824/1	—	070-001	In-Line Splice, Insulated and Environmental	—	G-17

Dimensions in inches (millimeters) and are subject to change without notice.



AS25042 and AS25043 Protective Plug and Receptacle Covers

MATING CONNECTOR

AS50151

Basic Part Number

MS25042 = Plug Cover
MS25043 = Receptacle Cover

Shell Size
(Table I)

Finish

D = Cadmium, O.D.
DA = Black Anodize

MS25042

- 20

D

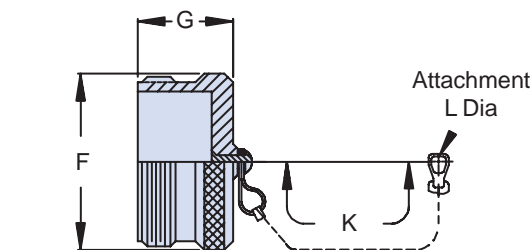

MS25042 Plug Cover

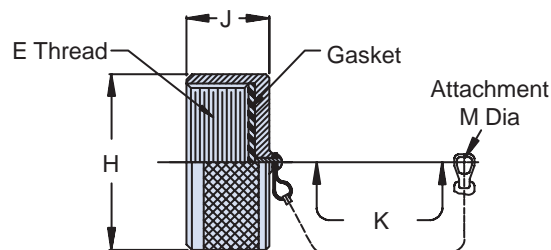

MS25043 Receptacle Cover

TABLE I: Shell Size, Thread, Attachment and Dimensions

Shell Size	E Thread	F Dia Max	G Max	H Max	J Max	K Attachment Length (Inches)	L Dia Min	M Dia Min
8	1/2- 28 UNEF	.562 (14.3)	.656 (16.7)	.688 (17.5)	.469 (11.9)	4.00 (101.6)	.151 (3.8)	.135 (3.4)
10	5/8- 24 UNEF	.687 (17.4)	.656 (16.7)	.815 (20.7)	.469 (11.9)	4.00 (101.6)	.151 (3.8)	.135 (3.4)
12	3/4- 20 UNEF	.812 (20.6)	.844 (21.4)	1.000 (25.4)	.469 (11.9)	4.50 (114.3)	.151 (3.8)	.135 (3.4)
14	7/8- 20 UNEF	.937 (23.8)	.844 (21.4)	1.125 (28.6)	.469 (11.9)	4.50 (114.3)	.151 (3.8)	.135 (3.4)
16	1- 20 UNEF	1.062 (27.0)	.844 (21.4)	1.188 (30.2)	.469 (11.9)	4.50 (114.3)	.151 (3.8)	.135 (3.4)
18	1 1/8- 18 UNEF	1.187 (30.1)	.844 (21.4)	1.344 (34.1)	.469 (11.9)	4.50 (114.3)	.151 (3.8)	.135 (3.4)
20	1 1/4- 18 UNEF	1.312 (33.3)	.844 (21.4)	1.469 (37.3)	.469 (11.9)	5.00 (127.0)	.182 (4.6)	.135 (3.4)
22	1 3/8- 18 UNEF	1.437 (36.5)	.844 (21.4)	1.594 (40.5)	.469 (11.9)	5.00 (127.0)	.182 (4.6)	.135 (3.4)
24	1 1/2- 18 UNEF	1.562 (39.7)	.844 (21.4)	1.719 (43.7)	.469 (11.9)	5.50 (139.7)	.182 (4.6)	.166 (4.2)
28	1 3/4- 18 UNS	1.812 (46.0)	.844 (21.4)	1.969 (50.0)	.531 (13.5)	7.75 (196.9)	.182 (4.6)	.166 (4.2)
32	2- 18 UNS	2.062 (52.4)	.844 (21.4)	2.219 (56.4)	.531 (13.5)	7.75 (196.9)	.213 (5.4)	.182 (4.6)
36	2 1/4- 16 UN	2.312 (58.7)	.844 (21.4)	2.469 (62.7)	.531 (13.5)	7.75 (196.9)	.213 (5.4)	.182 (4.6)
40	2 1/2- 16 UN	2.562 (65.1)	.844 (21.4)	2.719 (69.1)	.531 (13.5)	7.75 (196.9)	.213 (5.4)	.182 (4.6)
44	2 3/4- 16 UN	2.812 (71.4)	.844 (21.4)	2.969 (75.4)	.531 (13.5)	7.75 (196.9)	.213 (5.4)	.182 (4.6)
48	3- 16 UN	3.062 (77.8)	.844 (21.4)	3.188 (81.0)	.531 (13.5)	7.75 (196.9)	.213 (5.4)	.182 (4.6)

APPLICATION NOTES

1. Assembly identified with manufacturer's name and part number, space permitting.
2. For complete dimensions, see the applicable Military Specification.
3. Metric dimensions (mm) are in parentheses.

Dimensions in inches (millimeters) and are subject to change without notice.

MS17349 and MS17350 Protective Plug and Receptacle Covers



MATING CONNECTOR
MIL-DTL-22992

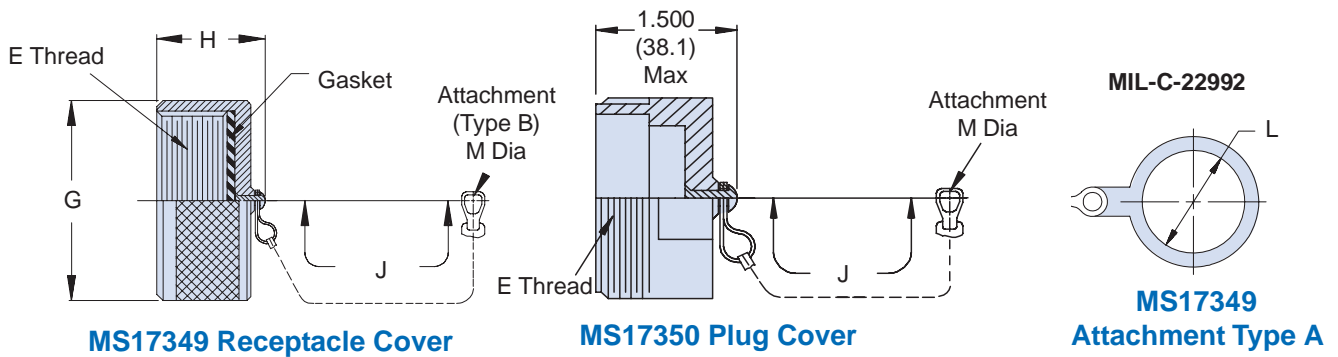
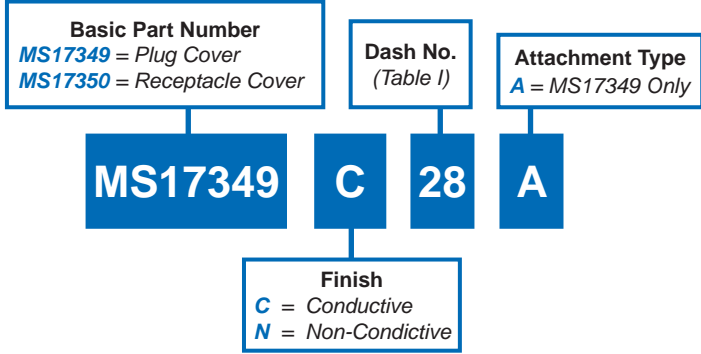

TABLE I: Dash Number, Thread, Attachment and Dimensions						
Dash No.	E Thread	G Max	H Max	J Chain Length (Inches)	L Min	M Dia Min
12	.8750-0.1P-0.2L-DS	1.094 (27.8)	.765 (19.4)	5.00 (127.0)	1.016 (25.8)	.150 (3.8)
14	1.0000-0.1P-0.2L-DS	1.219 (31.0)	.765 (19.4)	5.00 (127.0)	1.141 (29.0)	.150 (3.8)
16	1.1250-0.1P-0.2L-DS	1.344 (34.1)	.980 (24.9)	5.00 (127.0)	1.266 (32.2)	.150 (3.8)
18	1.2500-0.1P-0.2L-DS	1.469 (37.3)	.980 (24.9)	5.00 (127.0)	1.391 (35.3)	.177 (4.5)
20	1.3750-0.1P-0.2L-DS	1.562 (39.7)	.980 (24.9)	5.00 (127.0)	1.516 (38.5)	.177 (4.5)
22	1.5000-0.1P-0.2L-DS	1.688 (42.9)	.980 (24.9)	6.00 (152.4)	1.641 (41.7)	.177 (4.5)
24	1.7500-0.1P-0.2L-DS	1.938 (49.2)	.980 (24.9)	6.00 (152.4)	1.891 (48.0)	.177 (4.5)
28	2.0000-0.1P-0.2L-DS	2.219 (56.4)	.980 (24.9)	6.00 (152.4)	2.141 (54.4)	.177 (4.5)
32	2.2500-0.1P-0.2L-DS	2.469 (62.7)	.980 (24.9)	6.00 (152.4)	2.391 (60.7)	.199 (5.1)
36	2.5000-0.1P-0.2L-DS	2.719 (69.1)	.980 (24.9)	6.00 (152.4)	2.641 (67.1)	.199 (5.1)
40	2.7500-0.1P-0.2L-DS	2.969 (75.4)	.980 (24.9)	6.00 (152.4)	2.891 (73.4)	.199 (5.1)
44	3.0000-0.1P-0.2L-DS	3.219 (81.8)	.980 (24.9)	6.00 (152.4)	3.141 (79.8)	.199 (5.1)

APPLICATION NOTES
1. Assembly identified with manufacturer's name and part number, space permitting.
2. For complete dimensions, see the applicable Military Specification.
3. Metric dimensions (mm) are in parentheses.

Dimensions in inches (millimeters) and are subject to change without notice.





MS27291

Straight Non-Self-Locking Strain Relief

CONNECTOR DESIGNATOR:
E MIL-DTL-26500

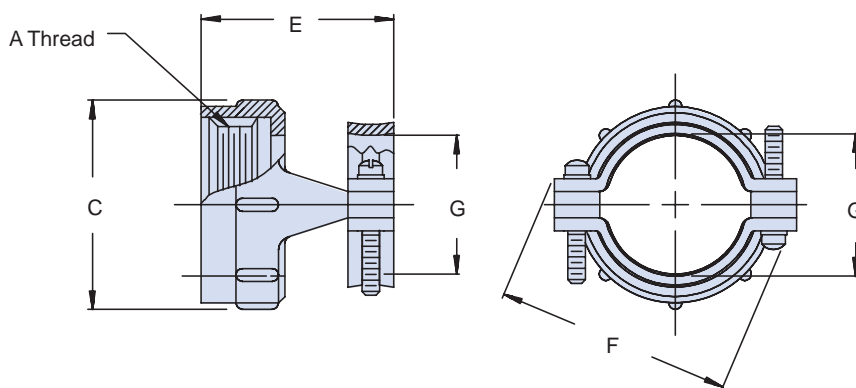
**Basic
Part Number**
**Dash
Number**
MS27291 - 401

TABLE I: Dash Number, Shell Size, Thread and Dimensions

Dash No. For Use with Class Connectors		Shell Size Ref.	A Thread Class 2B	C Max	E		F Max		Ø G	
R and F	G				±.015	(.4)			±.005	(.1)
1	101	10	.562 - 24 UNEF	.731 (18.6)	.935 (23.7)	.914 (23.2)	.270 (6.9)			
2	201	12	.750 - 20 UNEF	.919 (23.3)	.935 (23.7)	1.026 (26.1)	.400 (10.2)			
3	301	14	.812 - 20 UNEF	.981 (24.9)	1.170 (29.7)	1.090 (27.7)	.460 (11.7)			
4	401	16	.938 - 20 UNEF	1.106 (28.1)	1.170 (29.7)	1.250 (31.8)	.610 (15.5)			
5	501	18	1.062 - 18 UNEF	1.231 (31.3)	1.170 (29.7)	1.358 (34.5)	.690 (17.5)			
6	601	22	1.312 - 18 UNEF	1.481 (37.6)	1.170 (29.7)	1.604 (40.7)	.940 (23.9)			
13	701	8	.438 - 28 UNEF	.606 (15.4)	.935 (23.7)	.789 (20.0)	.186 (4.7)			
14	801	20	1.188 - 18 UNEF	1.356 (34.4)	1.170 (29.7)	1.481 (37.6)	.816 (20.7)			
15	901	24	1.438 - 18 UNEF	1.606 (40.8)	1.170 (29.7)	1.729 (43.9)	1.066 (27.1)			

APPLICATION NOTES

1. Finish: Class R and F—anodize, Class G, Chrome Plated
2. Assembly to be identified with manufacturer's name and part number, space permitting.
3. For complete dimensions, see the applicable Military Specification.
4. Metric dimensions (mm) are in parentheses.

Dimensions in inches (millimeters) and are subject to change without notice.

MS27558 90° Non-Self-Locking Strain Relief



CONNECTOR DESIGNATOR:	
E	MIL-DTL-26500

Basic Part Number	Dash Number
MS27558	- 3

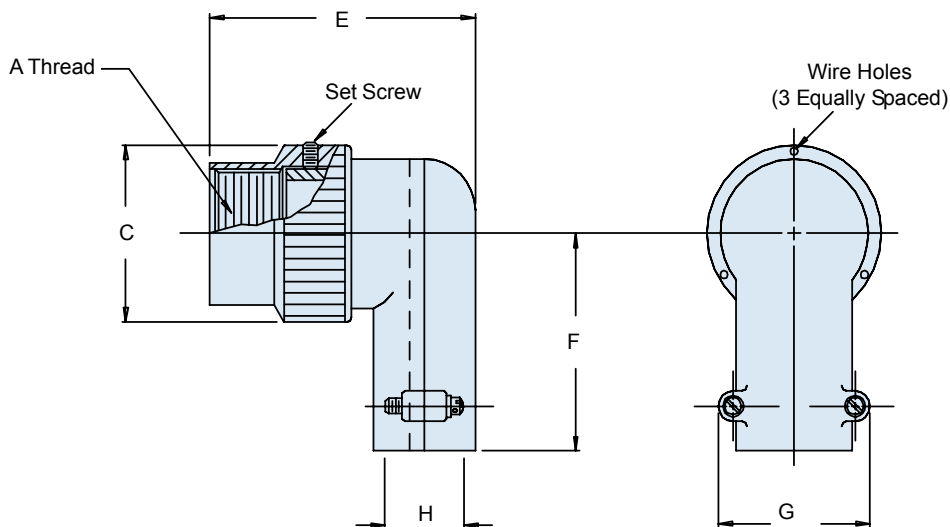

TABLE I: Dash Number, Shell Size, Thread and Dimensions											
Dash No.	Shell Size Ref.	A Thread Class 2B	C Max	E Max	F Max	G Max	H Dia				
1*	8	.437 - 28 UNEF	.672 (17.1)	1.200 (30.5)	.602 (15.3)	.892 (22.7)	.240 (6.1)				
2	10	.562 - 24 UNEF	.797 (20.2)	1.320 (33.5)	.650 (16.5)	1.072 (27.2)	.365 (9.3)				
3	12	.750 - 20 UNEF	1.016 (25.8)	1.320 (33.5)	.740 (18.8)	1.072 (27.2)	.365 (9.3)				
4	14	.812 - 20 UNEF	1.110 (28.2)	1.487 (37.8)	.775 (19.7)	1.108 (28.1)	.515 (13.1)				
5	16	.938 - 20 UNEF	1.234 (31.3)	1.470 (37.3)	.830 (21.1)	1.108 (28.1)	.515 (13.1)				
6	18	1.062 - 18 UNEF	1.360 (34.5)	1.588 (40.3)	.897 (22.8)	1.233 (31.3)	.640 (16.3)				
7	20	1.188 - 18 UNEF	1.485 (37.7)	1.759 (44.7)	.955 (24.3)	1.477 (37.5)	.775 (19.7)				
8	22	1.312 - 18 UNEF	1.610 (40.9)	1.759 (44.7)	1.015 (25.8)	1.477 (37.5)	.775 (19.7)				
9	24	1.438 - 18 UNEF	1.735 (44.1)	2.027 (51.5)	1.077 (27.4)	1.727 (43.9)	1.060 (26.9)				

* Consult Factory

- ### APPLICATION NOTES
1. Finish: Anodize.
 2. Assembly to be identified with manufacturer's name and part number, space permitting.
 3. For complete dimensions, see the applicable Military Specification.
 4. Metric dimensions (mm) are in parentheses.

Dimensions in inches (millimeters) and are subject to change without notice.



MS27559 90° Non-Self-Locking Strain Relief

CONNECTOR DESIGNATOR:
E MIL-DTL-26500

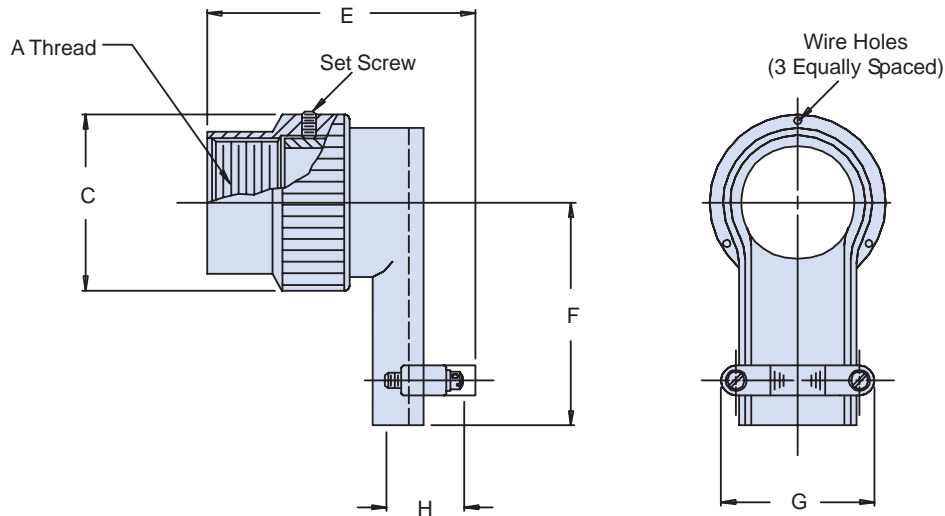
**Basic
Part Number**
**Dash
Number**
MS27559 - 4

TABLE I: Dash Number, Shell Size, Thread and Dimensions

Dash No.	Shell Size Ref.	A Thread Class 2B	C Max	E Max	F Max	G Max	H Dia
1	8	.437 - 28 UNEF	.672 (17.1)	1.173 (29.8)	.602 (15.3)	.892 (22.7)	.201 (5.1)
2	10	.562 - 24 UNEF	.797 (20.2)	1.293 (32.8)	.650 (16.5)	1.072 (27.2)	.320 (8.1)
3	12	.750 - 20 UNEF	1.016 (25.8)	1.293 (32.8)	.740 (18.8)	1.072 (27.2)	.320 (8.1)
4	14	.812 - 20 UNEF	1.110 (28.2)	1.460 (37.1)	.775 (19.7)	1.108 (28.1)	.452 (11.5)
5	16	.938 - 20 UNEF	1.234 (31.3)	1.443 (36.7)	.830 (21.1)	1.108 (28.1)	.508 (12.9)
6	18	1.062 - 18 UNEF	1.360 (34.5)	1.561 (39.6)	.897 (22.8)	1.233 (31.3)	.571 (14.5)
7	20	1.188 - 18 UNEF	1.485 (37.7)	1.732 (44.0)	.955 (24.3)	1.477 (37.5)	.748 (19.0)
8	22	1.312 - 18 UNEF	1.610 (40.9)	1.732 (44.0)	1.015 (25.8)	1.477 (37.5)	.748 (19.0)
9	24	1.438 - 18 UNEF	1.735 (44.1)	2.000 (50.8)	1.077 (27.4)	1.727 (43.9)	.996 (25.3)

APPLICATION NOTES

1. Finish: Anodize.
2. Assembly to be identified with manufacturer's name and part number, space permitting.
3. For complete dimensions, see the applicable Military Specification.
4. Metric dimensions (mm) are in parentheses.

Dimensions in inches (millimeters) and are subject to change without notice.

MS27741
TAG® Ring
 For Reliable Shield Terminations

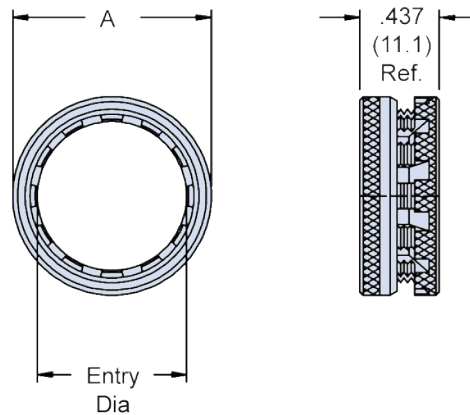
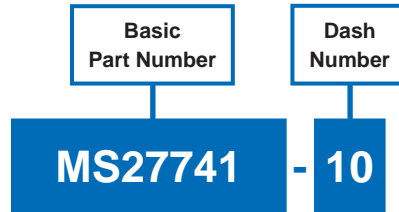

TABLE I: Shell Size, Entry, Slots and Weight

Dash No.	A Dia Max	Entry Dia	No. of Slots	Weight in Grams
2	.545 (13.8)	.250 (6.4)	3	2.268
3	.670 (17.0)	.375 (9.5)	4	2.722
4	.795 (20.2)	.500 (12.7)	6	3.175
5	.920 (23.4)	.625 (15.9)	8	4.082
6	1.045 (26.5)	.750 (19.1)	10	4.536
7	1.170 (29.7)	.875 (22.2)	10	4.990
8	1.295 (32.9)	1.000 (25.4)	12	5.443
9	1.420 (36.1)	1.125 (28.6)	15	6.350
10	1.687 (42.8)	1.250 (31.8)	15	10.433
11	1.812 (46.0)	1.375 (34.9)	15	14.515

APPLICATION NOTES

1. For complete dimensions see the applicable Military Specification.
2. Finish:
Body and Nut - Gold Iridite
Spring - Gold Plate
3. Metric dimensions (mm) are in parentheses.

Dimensions in inches (millimeters) and are subject to change without notice.



AS31051

Dummy Storage Receptacle Threaded Coupling

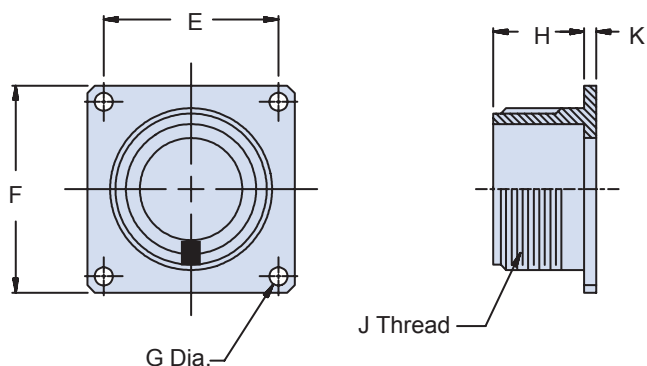
MATING CONNECTOR
AS50151
**Basic
Part No.**
Dash No.
MS3105 - 16

**TABLE I: Dash Number, Cable Entry
and Backshell Dimensions**

Shell Size	E		F Max	G Max		H Max		J Thread Class 2A	K Max		
	±.005	(.1)									
8S	.594	(15.1)	.906	(23.0)	.130	(3.3)	.593	(15.1)	1/2-28 UNEF	.156	(4.0)
10S	.719	(18.3)	1.031	(26.2)	.130	(3.3)	.593	(15.1)	5/8-24 UNEF	.156	(4.0)
12S	.812	(20.6)	1.125	(28.6)	.130	(3.3)	.593	(15.1)	3/4-20 UNEF	.156	(4.0)
12	.812	(20.6)	1.125	(28.6)	.130	(3.3)	.781	(19.8)	3/4-20 UNEF	.156	(4.0)
14S	.906	(23.0)	1.219	(31.0)	.130	(3.3)	.593	(15.1)	7/8-20 UNEF	.156	(4.0)
14	.906	(23.0)	1.219	(31.0)	.130	(3.3)	.781	(19.8)	7/8-20 UNEF	.156	(4.0)
16S	.969	(24.6)	1.312	(33.3)	.130	(3.3)	.593	(15.1)	1-20 UNEF	.156	(4.0)
16	.969	(24.6)	1.312	(33.3)	.130	(3.3)	.781	(19.8)	1-20 UNEF	.156	(4.0)
18	1.062	(27.0)	1.406	(35.7)	.130	(3.3)	.781	(19.8)	1 1/8-18 UNEF	.203	(5.2)
20	1.156	(29.4)	1.531	(38.9)	.130	(3.3)	.781	(19.8)	1 1/4-18 UNEF	.203	(5.2)
22	1.250	(31.8)	1.656	(42.1)	.130	(3.3)	.781	(19.8)	1 3/8-18 UNEF	.203	(5.2)
24	1.375	(34.9)	1.781	(45.2)	.157	(4.0)	.843	(21.4)	1 1/2-18 UNEF	.203	(5.2)
28	1.562	(39.7)	2.031	(51.6)	.157	(4.0)	.843	(21.4)	1 3/4-18 UNS	.203	(5.2)
32	1.750	(44.5)	2.281	(57.9)	.183	(4.6)	.906	(23.0)	2-18 UNS	.359	(9.1)
36	1.938	(49.2)	2.531	(64.3)	.183	(4.6)	.906	(23.0)	2 1/4-16 UN	.359	(9.1)
40	2.188	(55.6)	2.781	(70.6)	.183	(4.6)	.906	(23.0)	2 1/2-16 UN	.359	(9.1)
44	2.375	(60.3)	3.031	(77.0)	.183	(4.6)	.906	(23.0)	2 3/4-16 UN	.359	(9.1)
48	2.625	(66.7)	3.281	(83.3)	.183	(4.6)	.906	(23.0)	3-16 UN	.359	(9.1)

APPLICATION NOTES

1. Assembly to be identified with manufacturer's name and part number, space permitting.
2. For complete dimensions, see the applicable Military Specification.
3. Metric dimensions (mm) are in parentheses.

Dimensions in inches (millimeters) and are subject to change without notice.

MS3115 Dummy Storage Receptacle Bayonet Coupling



MATING CONNECTOR
MIL-DTL-26482

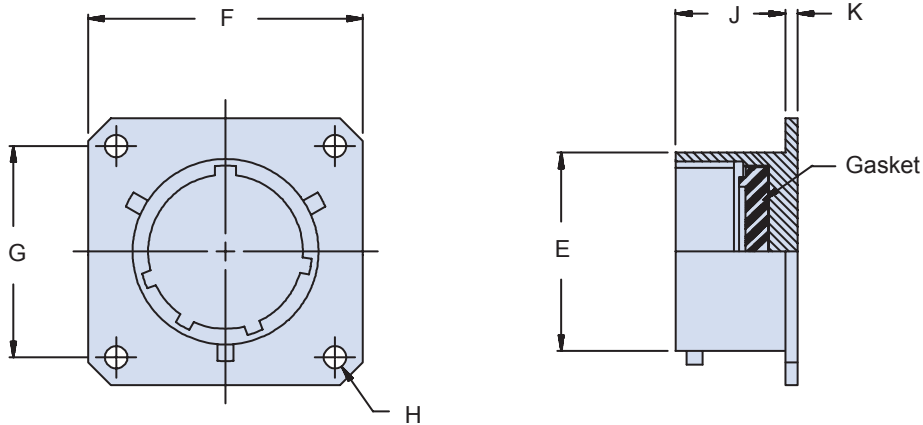
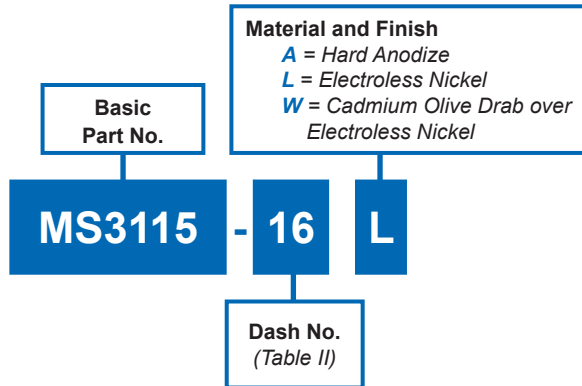

TABLE I: Dash Number, Cable Entry and Backshell Dimensions

Shell Size	E		F		G		Ø H		J		K	
	±.003	(.1)	Max	Dim	±.005	(0.1)	±.016	(.4)	±.016	(.4)		
8	.471	(12.0)	.828	(21.0)	.594	(15.1)	.120	(3.0)	.478	(12.1)	.062	(1.6)
10	.588	(14.9)	.954	(24.2)	.719	(18.3)	.120	(3.0)	.478	(12.1)	.062	(1.6)
12	.748	(19.0)	1.047	(26.6)	.812	(20.6)	.120	(3.0)	.478	(12.1)	.062	(1.6)
14	.873	(22.2)	1.141	(29.0)	.906	(23.0)	.120	(3.0)	.478	(12.1)	.062	(1.6)
16	.998	(25.3)	1.234	(31.3)	.969	(24.6)	.120	(3.0)	.478	(12.1)	.062	(1.6)
18	1.123	(28.5)	1.328	(33.7)	1.062	(27.0)	.120	(3.0)	.478	(12.1)	.062	(1.6)
20	1.248	(31.7)	1.453	(36.9)	1.156	(29.4)	.120	(3.0)	.572	(14.5)	.094	(2.4)
22	1.373	(34.9)	1.578	(40.1)	1.250	(31.8)	.120	(3.0)	.572	(14.5)	.094	(2.4)
24	1.498	(38.0)	1.703	(43.3)	1.375	(34.9)	.147	(3.7)	.605	(15.4)	.094	(2.4)

APPLICATION NOTES

1. Assembly to be identified with manufacturer's name and part number, space permitting.
2. For complete dimensions, see the applicable Military Specification.
3. Metric dimensions (mm) are in parentheses.

Dimensions in inches (millimeters) and are subject to change without notice.

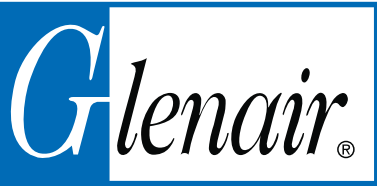

MS3180 and MS3181 Protective Plug and Receptacle Covers

MATING CONNECTOR
MIL-DTL-26482

Attachment Option
C = Chain
N = Chain with Ring (MS3181 Only)
R = Wire Rope

Length
L = Chain or Rope Length of 5 Inches (127.0 mm). Omit for Standard (See K in Table I)

Prior Revision D Available:

Finish is Cadmium Olive Drab

Attachment Option (Omit for None)
C = Chain
N = Chain with Ring (MS3181 Only)

MS3180 - 12 C

Basic Part Number
MS3180 = Plug Cover
MS3181 = Receptacle Cover

Shell Size

NOTE: prior revision parts will NOT carry the "JAN" marking

MS3180 - 12 C A L

Basic Part Number
MS3180 = Plug Cover
MS3181 = Receptacle Cover

Shell Size (Table I)

Finish
A = Anodize

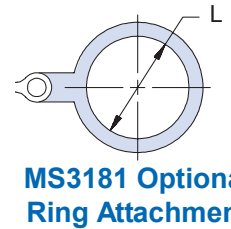
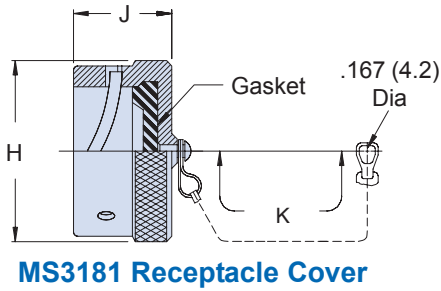
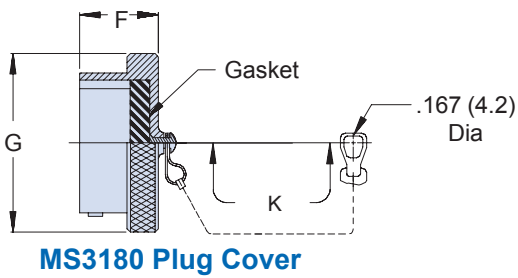

TABLE I: Shell Size, Dimensions and Attachment

Shell Size	F Max	G Dia Max	H Dia Max	J Max	K Standard Length (Inches)	L Min
8	.562 (14.3)	.719 (18.3)	.734 (18.6)	.562 (14.3)	3.00 (76.2)	.578 (14.7)
10	.562 (14.3)	.844 (21.4)	.859 (21.8)	.562 (14.3)	3.00 (76.2)	.703 (17.9)
12	.562 (14.3)	1.000 (25.4)	1.000 (25.4)	.562 (14.3)	3.50 (88.9)	.891 (22.6)
14	.562 (14.3)	1.125 (28.6)	1.125 (28.6)	.562 (14.3)	3.50 (88.9)	1.016 (25.8)
16	.562 (14.3)	1.250 (31.8)	1.250 (31.8)	.562 (14.3)	3.50 (88.9)	1.141 (29.0)
18	.562 (14.3)	1.375 (34.9)	1.375 (34.9)	.562 (14.3)	3.50 (88.9)	1.266 (32.2)
20	.625 (15.9)	1.500 (38.1)	1.500 (38.1)	.562 (14.3)	4.00 (101.6)	1.391 (35.3)
22	.625 (15.9)	1.625 (41.3)	1.625 (41.3)	.562 (14.3)	4.00 (101.6)	1.516 (38.5)
24	.658 (16.7)	1.750 (44.5)	1.750 (44.5)	.602 (15.3)	4.00 (101.6)	1.641 (41.7)

- APPLICATION NOTES**
1. Assembly identified with manufacturer's name and part number, space permitting.
 2. For complete dimensions, see the applicable Military Specification.
 3. Metric dimensions (mm) are in parentheses.

Dimensions in inches (millimeters) and are subject to change without notice.
Mil-Spec Backshells and Accessories U.S. CAGE Code 06324

MS3186 Jam Nut with Safety Wire Holes

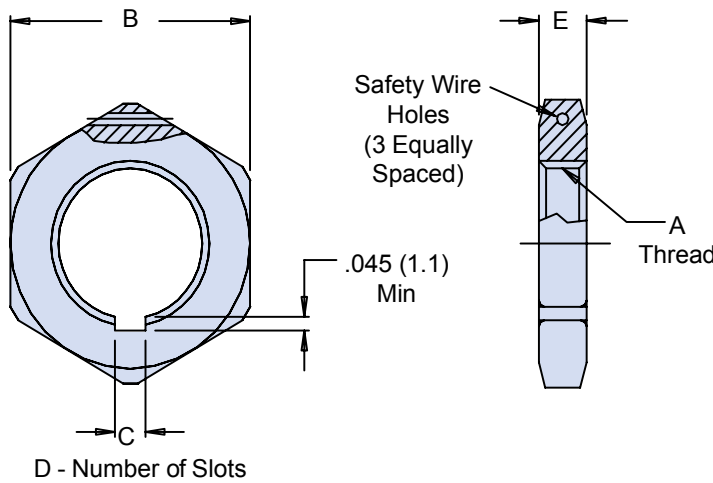

Basic Part Number	Material A = Aluminum S = Steel C = CRES	Dash No.
MS3186	A	- 113
		B

Finish

- A = Black Anodize (Material 'A' only)
- B = Black Cadmium over Corrosion Resistant Steel (Material 'C' only)
- C = Clear Cadmium (Material 'A' only)
- E = Electrodeposited Nickel
- N = Electroless Nickel (Space Use Only)
- P = Passivated (Material 'C' only)
- T = Tin Plate (Material 'S' only)
- W = 1,000 Hour Cadmium Olive Drab over Electroless Nickel

TABLE I: Reference for Connector Shell Size

Dash No.	AS50151	MIL-DTL-26482	MIL-DTL-26500	MIL-DTL-83723 I	MIL-DTL-83723 III	MIL-DTL-38999 I	MIL-DTL-38999 II	MIL-DTL-28840	MIL-DTL-27599
101	8S	--	--	--	--	--	--	--	--
102	--	8	--	8	--	--	--	--	--
103	10S, 10SL	--	--	--	--	--	--	--	--
104	--	--	8	--	--	--	--	--	--
105	--	--	--	--	8	--	--	--	--
106	--	10	--	10	--	9	--	--	9
107	12S, 12	--	10	--	10	--	--	--	--
108	--	--	--	--	--	11	--	--	11
109	14S, 14	12	--	12	--	--	8	11	8
110	--	--	12	--	12	--	--	--	--
111	16S, 16	14	14	14	14	13	10	13	10, 13
112	--	--	16	--	16 Bay	--	--	--	--
113	18	16	--	16	16 Thd	15	12	--	12, 15
114	--	--	--	--	--	--	--	15	--
115	--	--	18	--	--	--	--	--	14, 17
116	20	18	--	18	18	17	14	17	--
117	22	20	20	20	20	19	16	--	16, 19
118	--	--	--	--	--	--	--	19	--
119	--	--	22	--	--	--	--	--	--
120	24	22	--	22	22	21	18	--	18, 21
121	--	24	24	24	24	23	20	23	20, 23
122	28	--	--	--	--	25	22	25	22, 25
123	--	--	--	--	--	--	24	--	24
124	--	--	--	--	--	--	--	29	--
125	32	--	--	--	--	--	--	--	--
126	--	--	--	--	--	--	--	33	--
127	36	--	--	--	--	--	--	--	--
128	40	--	--	--	--	--	--	--	--
129	44	--	--	--	--	--	--	--	--
130	48	--	--	--	--	--	--	--	--

Dimensions in inches (millimeters) and are subject to change without notice.



MS3186 Jam Nut with Safety Wire Holes

TABLE I: Reference for Connector Shell Size

Dash No.	A Thread	B		C		D Min. No. of Slots	Ø E	
		±.017	(.4)	Max			±.017	(.4)
101	.500 -28 UNEF-2B	.687	(17.4)	None		None	.125	(3.2)
102	.5625 - 24 UNEF-2B	.750	(19.1)	.135	(3.4)	2	.125	(3.2)
103	.625 - 24 UNEF-2B	.812	(20.6)	None		None	.125	(3.2)
104	.625 - 20 UN-2B	.812	(20.6)	.135	(3.4)	2	.125	(3.2)
105	.625 - 20 UN-2B	.812	(20.6)	None		2	.125	(3.2)
106	.6875 - 24 UNEF-2B	.875	(22.2)	.135	(3.4)	1	.125	(3.2)
107	.750 - 20 UNEF-2B	.937	(23.8)	None		2	.125	(3.2)
108	.8125 - 20 UNEF-2B	1.000	(25.4)	.135	(3.4)	1	.125	(3.2)
109	.875 - 20 UNEF-2B	1.062	(27.0)	.135	(3.4)	1	.125	(3.2)
110	.9375 - 20 UNEF-2B	1.123	(28.5)	None		1	.125	(3.2)
111	1.000 - 20 UNEF-2B	1.188	(30.2)	.135	(3.4)	1	.125	(3.2)
112	1.125 - 20 UN-2B	1.312	(33.3)	.135	(3.4)	1	.125	(3.2)
113	1.125 - 18 UNEF-2B	1.312	(33.3)	.135	(3.4)	1	.125	(3.2)
114	1.1875 - 18 UNEF-2B	1.375	(34.9)	None		None	.125	(3.2)
115	1.250 - 20 UN-2B	1.438	(36.5)	None		None	.125	(3.2)
116	1.250 - 18 UNEF-2B	1.438	(36.5)	.135	(3.4)	1	.125	(3.2)
117	1.375 - 18 UNEF-2B	1.562	(39.7)	.192	(4.9)	1	.125	(3.2)
118	1.4375 - 18 UNEF-2B	1.625	(41.3)	None		None	.125	(3.2)
119	1.500 - 20 UN-2B	1.688	(42.9)	None		None	.125	(3.2)
120	1.500 - 18 UNEF-2B	1.688	(42.9)	.192	(4.9)	1	.125	(3.2)
121	1.625 - 18 UNEF-2B	1.812	(46.0)	.192	(4.9)	1	.125	(3.2)
122	1.750 - 18 UNS-2B	2.000	(50.8)	.192	(4.9)	1	.125	(3.2)
123	1.875 - 16 UN-2B	2.125	(54.0)	None		None	.125	(3.2)
124	1.9375 - 16 UN-2B	2.187	(55.5)	None		None	.189	(4.8)
125	2.000 - 18 UNS-2B	2.250	(57.2)	None		None	.189	(4.8)
126	2.125 - 16 UN-2B	2.375	(60.3)	None		None	.189	(4.8)
127	2.250 - 16 UN-2B	2.500	(63.5)	None		None	.189	(4.8)
128	2.500 - 16 UN-2B	2.750	(69.9)	None		None	.189	(4.8)
129	2.750 - 16 UN-2B	3.000	(76.2)	None		None	.189	(4.8)
130	3.000 - 16 UN-2B	3.250	(82.6)	None		None	.189	(4.8)

APPLICATION NOTES

1. Assembly identified with manufacturer's name and part number, space permitting.
2. For complete dimensions, see the applicable Military Specification.
3. Metric dimensions (mm) are in parentheses.

Dimensions in inches (millimeters) and are subject to change without notice.

M29504/04

181-002

Size 16 MIL-DTL-38999 Series III Type
Fiber Optic Pin Terminus

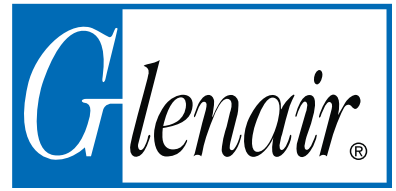

Misc. Backshells
and Accessories



Ultra low dB loss QPL'd pin terminus for MIL-DTL-38999 Series III



Part Number	Fiber Size Core/Cladding/Coating	Ø A (Microns)	Ref. M29504/04-XXXX
181-002-125	9/125 (Singlemode)	125.5	M29504/04-4208
181-002-126S	9/125 (Singlemode)	126.0	M29504/04-4209
181-002-126	50/125 & 62.5/125	126.0	M29504/04-4210
181-002-127	50/125 & 62.5/125	127.0	M29504/04-4040
181-002-142	100/140	142.0	M29504/04-4043
181-002-144	100/140	144.0	N/A
181-002-145	100/140	145.0	M29504/04-4044
181-002-156	62.5/125/155 (Polyimide)	156.0	M29504/04-4211
181-002-157	62.5/125/155 (Polyimide)	157.0	M29504/04-4212
181-002-173	100/140/172 (Polyimide)	173.0	M29504/04-4087
181-002-175	100/140/172 (Polyimide)	175.0	M29504/04-4213
181-002-231	200/230	231.0	N/A
181-002-236	200/233	236.0	M29504/04-4214
181-002-286	200/280	286.0	M29504/04-4215
181-002-448	400/440	448.0	M29504/04-4216
181-002-533	486/500	533.0	N/A

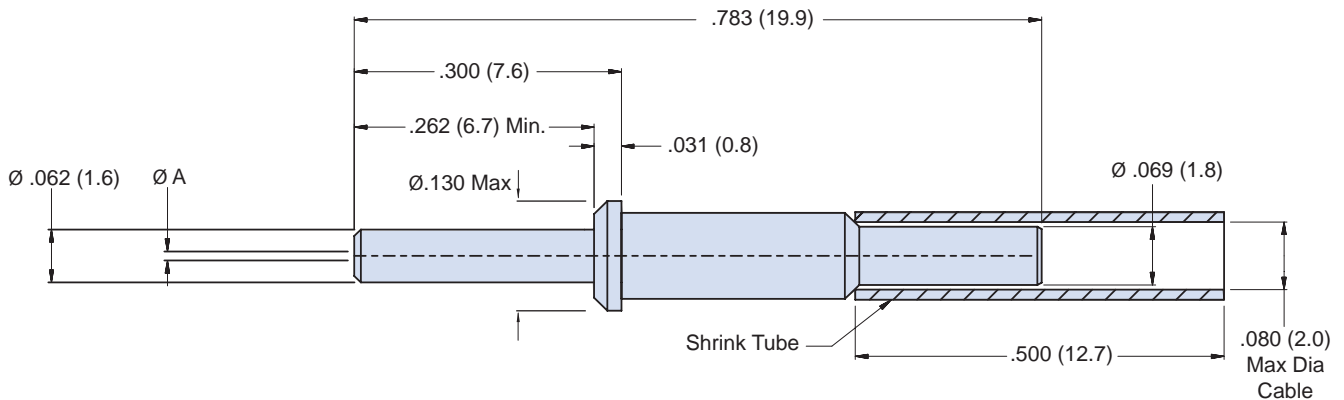

Material and Finish

Ferrule: Zirconia Ceramic
Terminus Assembly: Stainless Steel/Passivate
Shrink Tube: Kynar

Notes

See Glenair assembly procedure GAP-015 for complete termination instructions.
Recommended Insertion/Extraction tool: P/N M81969/14-03 or equivalent

Dimensions in inches (millimeters) and are subject to change without notice.

© 2013 Glenair, Inc.

U.S. CAGE Code 06324

Printed in U.S.A.

G

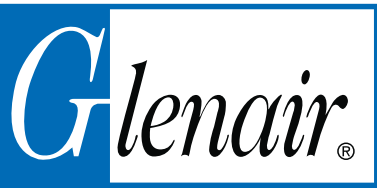

M29504/05
181-001
Size 16 MIL-DTL-38999 Series III Type
Fiber Optic Socket Terminus



Ultra low dB loss QPL'd socket terminus for MIL-DTL-38999 Series III



Part Number	Fiber Size Core/Cladding/Coating (Microns)	Ø A (Microns)	Ref. M29504/05-XXXX
181-001-125	9/125 (Singlemode)	125.5	M29504/05-4237
181-001-126S	9/125 (Singlemode)	126.0	M29504/05-4238
181-001-126	50/125 & 62.5/125	126.0	M29504/05-4239
181-001-127	50/125 & 62.5/125	127.0	M29504/05-4046
181-001-142	100/140	142.0	M29504/05-4049
181-001-144	100/140	144.0	N/A
181-001-145	100/140	145.0	M29504/05-4050
181-001-156	62.5/125/155 (Polyimide)	156.0	M29504/05-4240
181-001-157	62.5/125/155 (Polyimide)	157.0	M29504/05-4241
181-001-173	100/140/172 (Polyimide)	173.0	M29504/05-4088
181-001-175	100/140/172 (Polyimide)	175.0	M29504/05-4242
181-001-231	200/230	231.0	N/A
181-001-236	200/233	236.0	M29504/05-4243
181-001-286	200/280	286.0	M29504/05-4244
181-001-448	400/440	448.0	M29504/05-4245
181-001-533	486/500	533.0	N/A

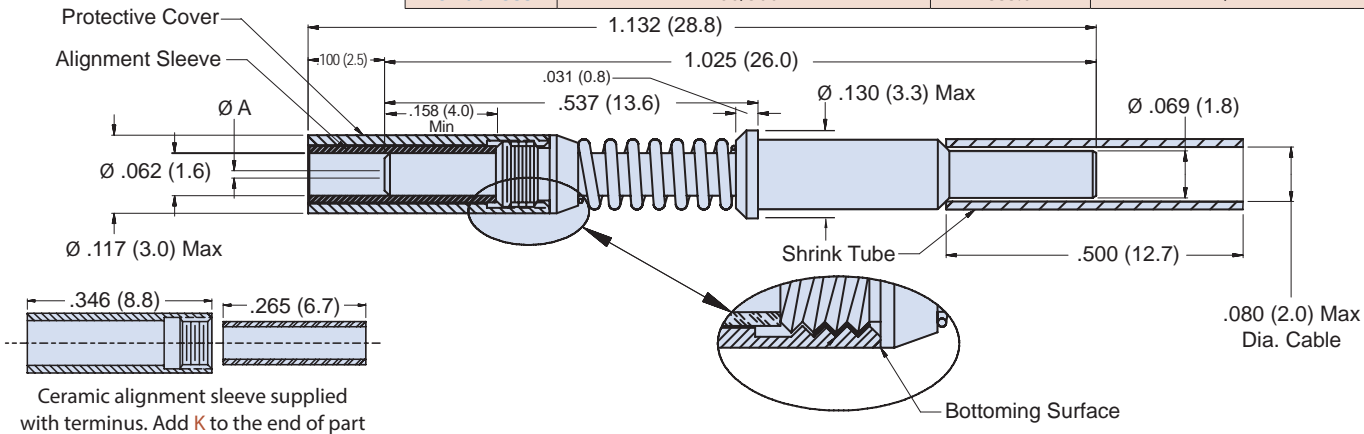

Ceramic alignment sleeve supplied with terminus. Add **K** to the end of part number development to supply with optional stainless steel alignment sleeve e.g. 181-001-126**K**.

Table II: Accessories

Part Number	Description
181-001-S	Ceramic Alignment Sleeve
181-001-K	Stainless Steel Alignment Sleeve
181-001-C	Protective cover

Material and Finish
 Ferrule: Zirconia Ceramic
 Alignment Sleeve: Zirconia Ceramic or Stainless Steel/Passivate.
 Terminus Assembly: Stainless Steel/Passivate
 Spacer, Spring, and Cover: Stainless Steel/Passivate • Shrink Tube: Kynar

Notes
 Alignment Sleeve & Protective Cover can also be ordered separately (Table II).
 See assembly procedure GAP-015 for complete termination instructions.
 Recommended Insertion/Extraction tool: P/N M81969/14-03 or equivalent

Dimensions in inches (millimeters) and are subject to change without notice.





© 2013 Glenair, Inc. U.S. CAGE Code 06324 Printed in U.S.A.

MIL-DTL-83513/05 Micro-D Jackscrew Kits

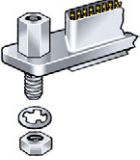
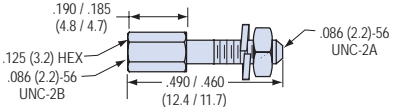
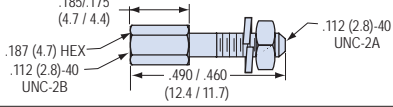
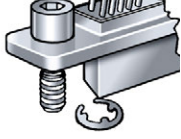
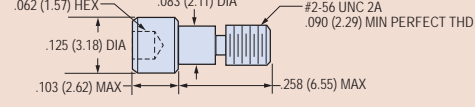
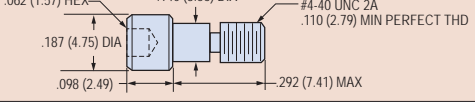

Order One Kit Per Connector. Jackpost kits contain two posts, two hex nuts and 2 lockwashers. Jackscrew kits contain 2 screws and 2 e-rings. Packaged one kit (two screws or posts) per bag.

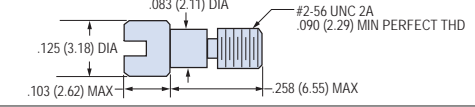
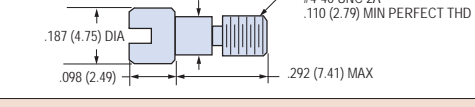
Mil Spec Hardware Kits feature 300 series stainless steel.

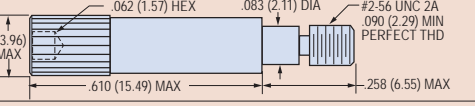
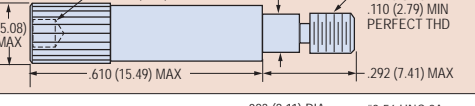
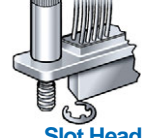
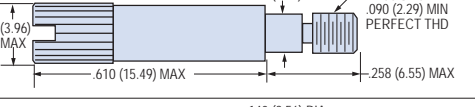
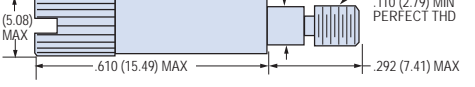
MIL SPEC JACKSCREW KITS				
Configuration	Connector Size, Thread Size	Mil Spec Part Number	Glenair Part Number	Dimensions
 Jackpost	Sizes 9 to 69 Contacts. Mil Spec Size A to G #2-56 UNC	M83513/05-07	080-00-00-100	
	Size 100 Only Mil Spec Size H #4-40 UNC	M83513/05-17	080-00-00-101	
 Hex Head Jackscrew Low Profile	Sizes 9 to 69 Contacts. Mil Spec Size A to G #2-56 UNC-2A	M83513/05-02	080-00-00-502	
	Size 100 Only Mil Spec Size H #4-40 UNC-2A	M83513/05-12	080-00-00-512	
 Slot Head Jackscrew Low Profile	Sizes 9 to 69 Contacts. Mil Spec Size A to G #2-56 UNC-2A	M83513/05-05	080-00-00-505	
	Size 100 Only Mil Spec Size H #4-40 UNC-2A	M83513/05-15	080-00-00-515	
 Hex Head Jackscrew Extended	Sizes 9 to 69 Contacts. Mil Spec Size A to G #2-56 UNC-2A	M83513/05-03	080-00-00-503	
	Size 100 Only Mil Spec Size H #4-40 UNC-2A	M83513/05-13	080-00-00-513	
 Slot Head Jackscrew Extended	Sizes 9 to 69 Contacts. Mil Spec Size A to G #2-56 UNC-2A	M83513/05-06	080-00-00-506	
	Size 100 Only Mil Spec Size H #4-40 UNC-2A	M83513/05-16	080-00-00-516	

Dimensions in inches (millimeters) and are subject to change without notice.

M83538/9S Straight Adapter and Extender

CONNECTOR DESIGNATOR:

MIL-DTL-83538/4

Basic
Part NumberShell
Size

M83538/9S - 09

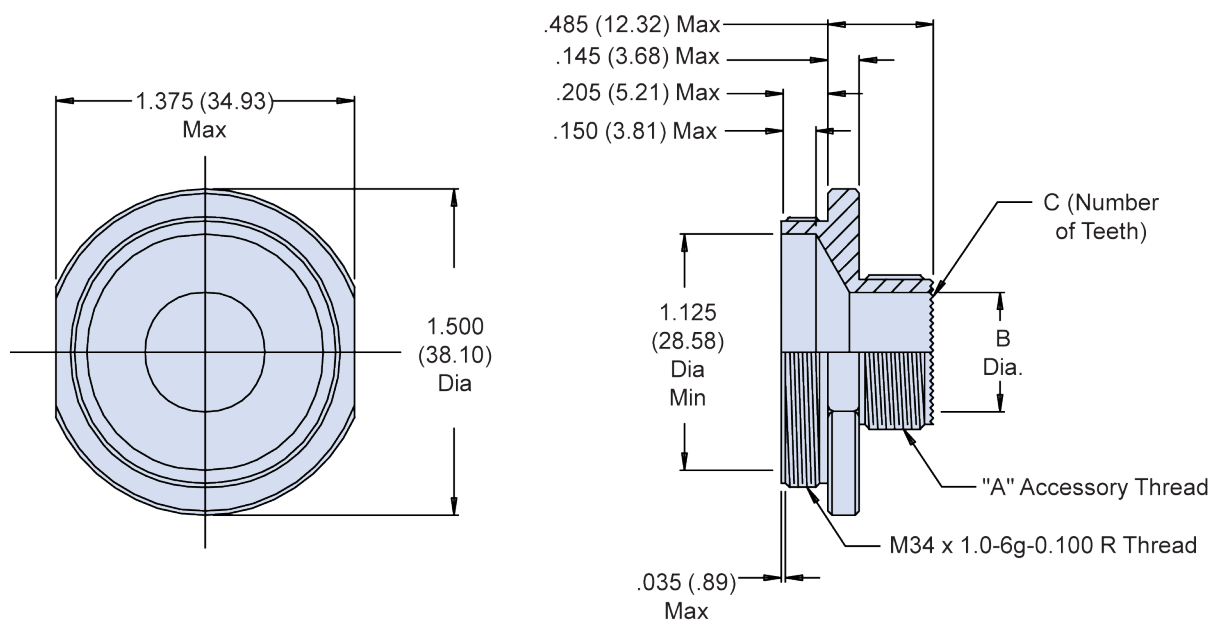

TABLE I: Shell Size, Thread, Teeth and Dimensions

Shell Size	"A" Accessory Thread	B Dia ±.005 (0.13)	C Number of Teeth
09	M12x1.0-6g 0.100R	.332 (8.18)	12
11	M15x1.0-6g 0.100R	.440 (11.18)	16
13	M18x1.0-6g 0.100R	.559 (14.20)	20
15	M22x1.0-6g 0.100R	.716 (18.19)	24
17	M25x1.0-6g 0.100R	.834 (21.18)	28
19	M28x1.0-6g 0.100R	.952 (24.18)	32
21	M31x1.0-6g 0.100R	1.070 (27.18)	36
23	M34x1.0-6g 0.100R	1.188 (30.18)	40

APPLICATION NOTES

- For complete dimensions see the applicable Military Specification.
- Material is corrosion resistant steel.
- Metric dimensions (mm) are in parentheses.

Dimensions in inches (millimeters) and are subject to change without notice.

M81824/1 • 070-001
MIL-Qualified Splice
In-Line, Insulated, Environmental



Misc. Backshells
and Accessories

Product Series	Size <i>(Table I, Page G-18)</i>
M81824/1	1

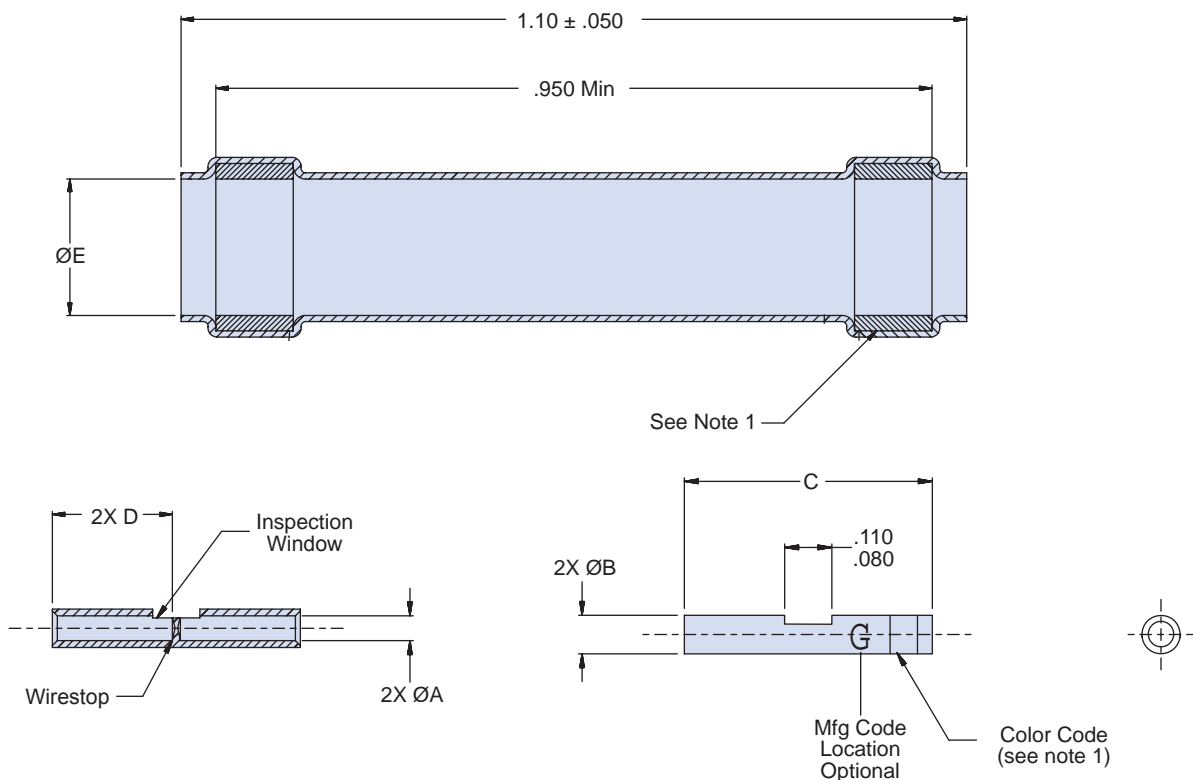

APPLICATION NOTES

1. For complete dimensions see the applicable Military Specification.
2. One seal ring must be color coded per Table I. Splice to have matching circumferential color stripe.
3. Metric dimensions (mm) are in parentheses.
4. Material and Finish:
 Splice – Copper UNS C10100 ASTM F68 or ASTM B187.
 Finish – Tin plate per ASTM B 545, .00010 min thick over nickel per AMS-QQ-N-290.
 Sealing material – Thermally stabilized thermoplastic.
 Shrink Sleeve – transparent, heat shrinkable, cross-linked polyvinylidene fluoride per AMS-DTL-23053/8.

Dimensions in inches (millimeters) and are subject to change without notice.



Size	Wire Range	A Dia	B Dia	C	D	E Dia		Mil Ref	Color Code (note 1)
						Min (Free State)	After Recovery Ref		
01	20–26 AWG	.050 (1.27)	.080 (2.03)	.510 (12.95)	.245 (6.22)	.085 (2.2)	.025 (0.6)	M81824/1-1	Red
		.045 (1.14)	.075 (1.90)	.490 (12.45)	.225 (5.72)				
02	16–20 AWG	.069 (1.75)	.106 (2.69)	.585 (14.86)	.280 (7.11)	.110 (2.8)	.025 (0.6)	M81824/1-2	Blue
		.064 (1.63)	.101 (2.57)	.565 (14.35)	.260 (6.60)				
03	12–16 AWG	.102 (2.59)	.153 (3.89)	.585 (14.86)	.280 (7.11)	.170 (4.3)	.025 (0.6)	M81824/1-3	Yellow
		.097 (2.46)	.147 (3.74)	.565 (14.35)	.260 (6.60)				

ASSEMBLY INSTRUCTIONS

Step A

- Strip wires per Table II. Ends must be cut cleanly and at right angles to the axial plane of the wire. The wire must not be deformed while making cuts.

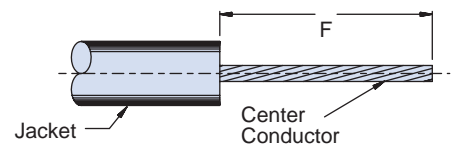

Step B

- Slide Insulation Sleeve onto one of the wires

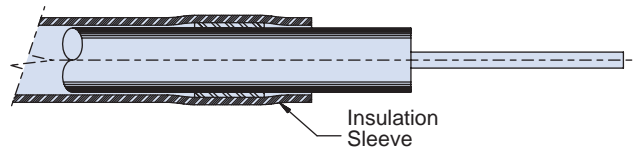

Step C

- Insert one wire into barrel of crimp splice and crimp using crimp tool and dies listed in Table II.
- Repeat for second wire.

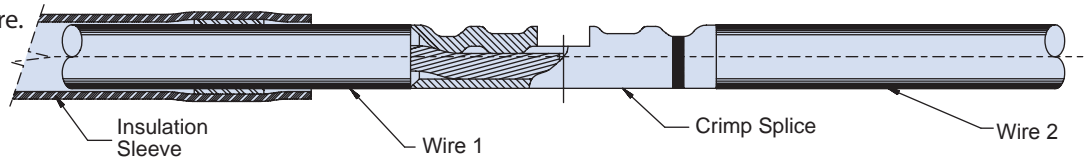

Step D

- Slide Insulation Sleeve over the splice until centered.
- Apply heat using acceptable heat source for military equipment as qualified by the services for Class 2 splices. Sealing rings shall melt and insulation sleeve shall seal around crimp splice and wires.

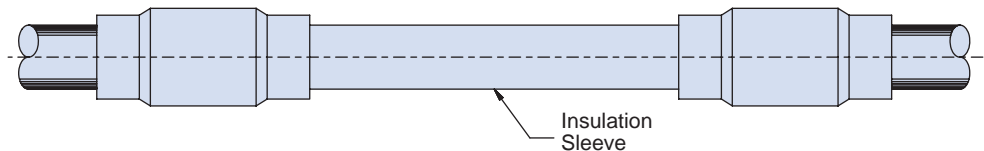

Part No.	Wire Range	F	Crimp Tool Data
070-00101	20, 22, 24, 26	.24	Crimp Tool: M22520/5-01 Crimp Dies: M22520/5-102, -103
070-00102	16, 18, 20	.28	OR Crimp Tool: M22520/10-01 Crimp Dies: M22520/10-103, -104
070-00103	12, 14, 16	.28	OR Crimp Tool: M22520/37-01 Crimp Dies: None

Dimensions in inches (millimeters) and are subject to change without notice.

Backshell-to-Connector Assembly Tools



Industry Specification Number	Part Identification Number	Military Part Number Superseded	Glenair Commercial Part Number	Description	Glenair Connector Designator/Interface	Page No.
--	--	--	TG37	Connector Wrench for MIL-DTL-26500 and MIL-DTL-83723 Series III	MIL-DTL-26500; MIL-DTL-83723 Series III	H-2
--	MS3481	--	TG39	Connector Wrench for MIL-DTL-26482, Ser. I & II; MIL-DTL-83723, Ser. I & NAS 1599	MIL-DTL-26482 Series I & II; MIL-DTL-83723 Series I; NAS 1599	H-3
--	--	--	TG47	Connector Wrench for MIL-DTL-22992, Classes C, J and R	MIL-DTL-22992, Classes C, J and R	H-4
--	--	--	TG48	Connector Wrench for MIL-DTL-38999, Series II	MIL-DTL-38999 Series II	H-5
--	--	--	TG52	Connector Wrench for MIL-C-81511, Series II and IV	MIL-C-81511 Series II & IV	H-6
--	--	--	TG60	Connector Wrench for MIL-DTL-27599 and MIL-DTL-38999, Series I	MIL-DTL-27599; MIL-DTL-38999 Series I	H-7
--	--	--	TG83	Wrench for SJT Connectors (LN29729)	LN29729	H-8
--	--	--	TG90	Connector Wrench For MIL-DTL-38999, Ser III	MIL-DTL-38999 Series III	H-9
--	--	--	600B005	Plug and Receptacle Holder for MIL-DTL-501555 Series MS3100 Solder & Crimp and MIL-DTL-83723, Series II	MIL-DTL-50155 Series MS3100 Solder and Crimp; MIL-DTL-83723 Series II	H-10
--	--	--	600C005	Plug and Receptacle Holder for MIL-DTL-22992 Classes C, J and R	MIL-DTL-22992 Classes C, J and R	H-11
--	--	--	600D005	Plug and Receptacle Holder for MIL-DTL-26482, Series I and II, MIL-DTL-83723, Series I and NAS 1599	MIL-DTL-26482 Series I & II; MIL-DTL-83723 Series I; NAS 1599	H-12
--	--	--	600E005	Plug and Receptacle Holder for MIL-DTL-26500 and MIL-DTL-83723 Series III	MIL-DTL-26500; MIL-DTL-83723 Series III	H-13
--	--	--	600F005	Plug and Receptacle Holder for MIL-DTL-27599 and MIL-DTL-38999 Series I	MIL-DTL-27599; MIL-DTL-38999 Series I	H-14
--	--	--	600FF005	Plug and Receptacle Holder for MIL-DTL-38999, Series II	MIL-DTL-38999 Series II	H-15
--	--	--	600G005	Plug and Receptacle Holder for MIL-DTL-28840	MIL-DTL-28840	H-16
--	--	--	600H005	Plug and Receptacle Holder for MIL-DTL-38999, Series III	MIL-DTL-38999 Series III	H-17
--	--	--	600HH005	Plug and Receptacle Holder for MIL-DTL-38999, Series IV	MIL-DTL-38999 Series IV	H-18
--	--	--	600J005	Plug and Receptacle Holder for MIL-DTL-81511, Series I, II, III and IV	MIL-DTL-81511 Series I, II, III & IV	H-19

Dimensions in inches (millimeters) and are subject to change without notice.



TG37 Connector Wrench MIL-DTL-26500, MIL-DTL-83723 Series III

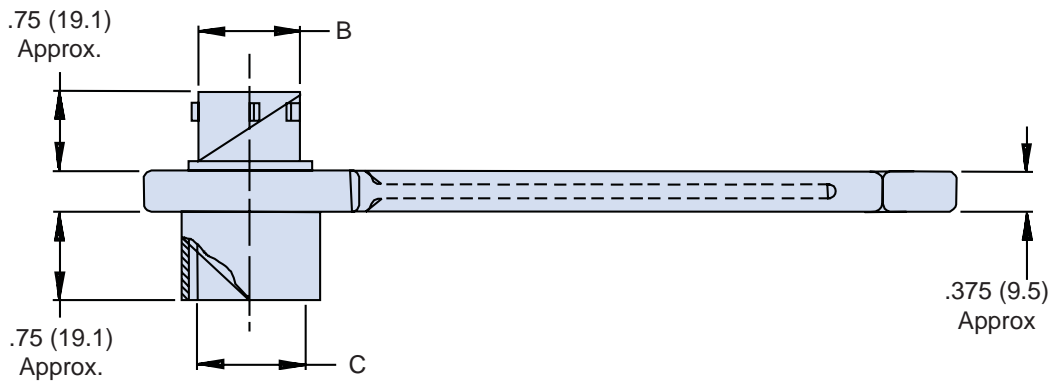
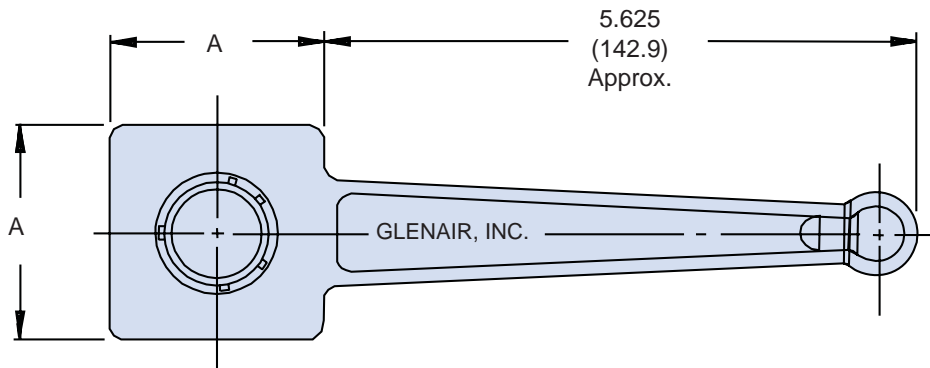
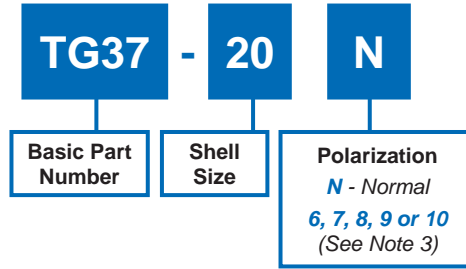

TABLE I: Dash Number and Dimensions

Dash No.	A Dim ± .062(1.6)	B Dia Ref	C Dia Ref
8	1.250 (31.8)	.424 (10.8)	.428 (10.9)
10	1.250 (31.8)	.526 (13.4)	.530 (13.5)
12	1.250 (31.8)	.696 (17.7)	.700 (17.8)
14	2.000 (50.8)	.765 (19.4)	.769 (19.5)
16	2.000 (50.8)	.892 (22.7)	.896 (22.8)
18	2.000 (50.8)	.998 (25.3)	1.002 (25.5)
20	2.000 (50.8)	1.123 (28.5)	1.127 (28.6)
22	2.000 (50.8)	1.248 (31.7)	1.252 (31.8)
24	2.000 (50.8)	1.373 (34.9)	1.377 (35.0)

APPLICATION NOTES

1. Metric dimensions (mm) are indicated in parentheses.
2. Material: Aluminum alloy with electroless nickel finish.
3. Polarization 10 not available for shell size 8.
4. Wrench has been designed to be used with both threaded and bayonet style connectors.

Dimensions in inches (millimeters) and are subject to change without notice.

TG39
Connector Wrench
MIL-DTL26482 Series I and II, MIL-DTL-83723 Series I and NAS 1599

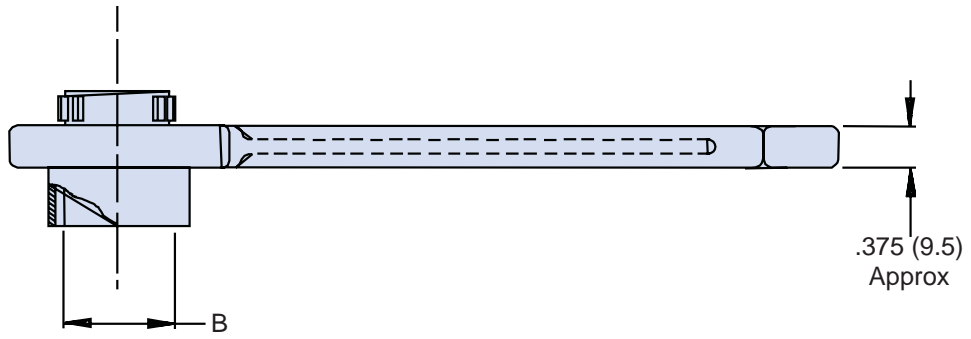
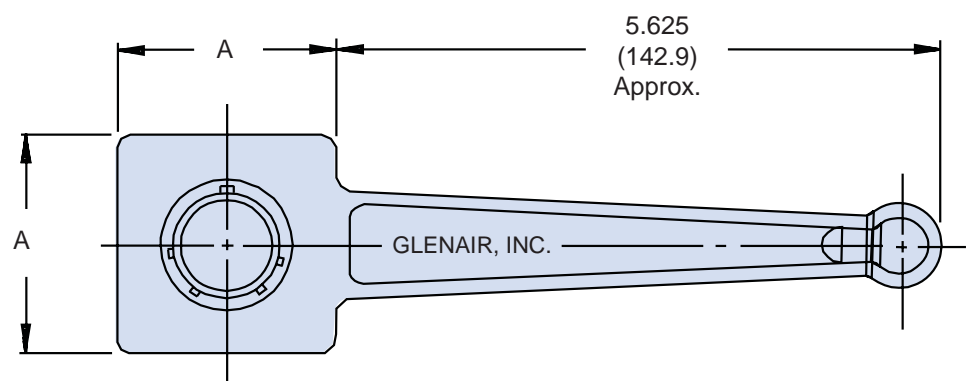
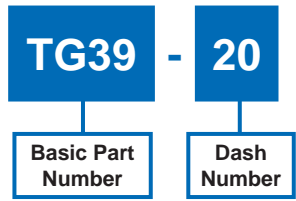

TABLE I: Shell Size and Dimensions

Shell Size	A Dim ± .062 (1.6)	B Dia Ref
8	1.250 (31.8)	.362 (9.2)
10	1.250 (31.8)	.490 (12.4)
12	1.250 (31.8)	.607 (15.4)
14	1.250 (31.8)	.732 (18.6)
16	2.000 (50.8)	.857 (21.8)
18	2.000 (50.8)	.962 (24.4)
20	2.000 (50.8)	1.087 (27.6)
22	2.000 (50.8)	1.212 (30.8)
24	2.000 (50.8)	1.337 (34.0)

- APPLICATION NOTES**
1. Metric dimensions (mm) are indicated in parentheses.
 2. Material: Aluminum alloy with electroless nickel finish.



Dimensions in inches (millimeters) and are subject to change without notice.



TG47 Connector Wrench MIL-DTL-22992 Classes C, J & R

TG47 - 20

Basic Part
Number

Dash
Number

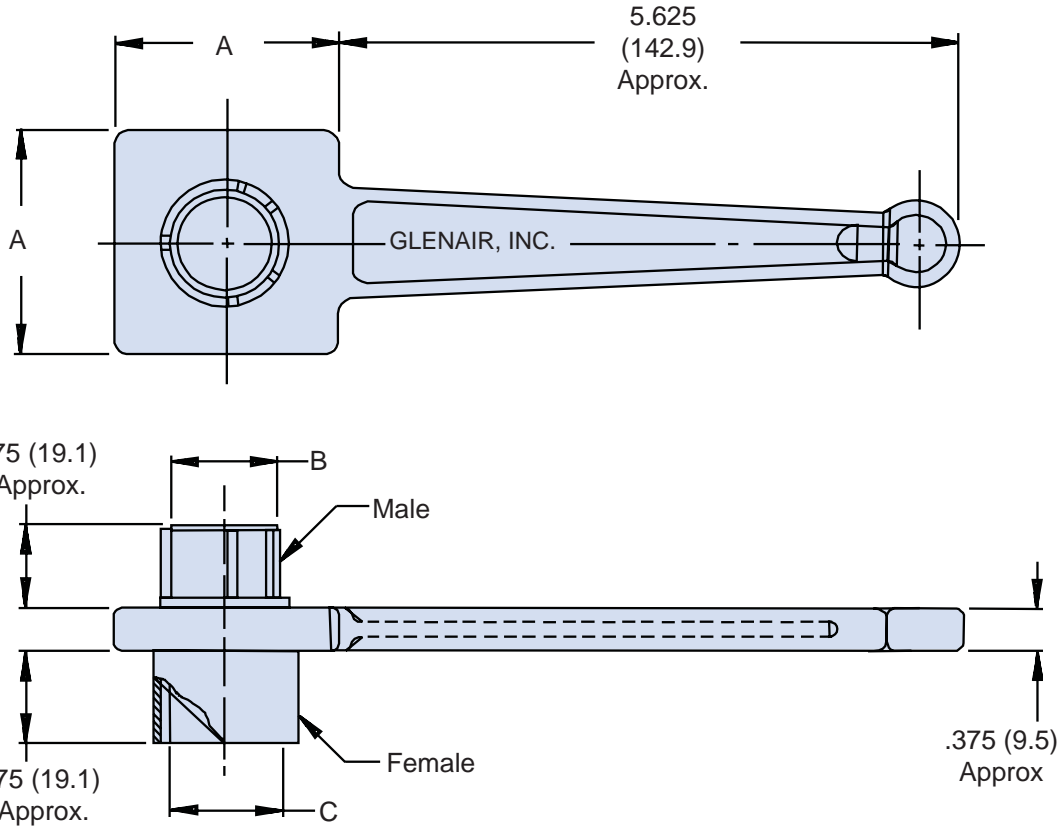

TABLE I: Shell Size and Dimensions

Shell Size	A Dim ± .062 (1.6)	B Dia Ref	C Dia Ref
12	1.250 (31.8)	.554 (14.1)	.567 (14.4)
14	2.000 (50.8)	.674 (17.1)	.692 (17.6)
16	2.000 (50.8)	.804 (20.4)	.817 (20.8)
18	2.000 (50.8)	.929 (23.6)	.942 (23.9)
20	2.000 (50.8)	1.052 (26.7)	1.068 (27.1)
22	2.750 (69.9)	1.177 (29.9)	1.192 (30.3)
24	2.750 (69.9)	1.302 (33.1)	1.317 (33.5)
28	2.750 (69.9)	1.522 (38.7)	1.536 (39.0)
32	2.750 (69.9)	1.772 (45.0)	1.786 (45.4)
36	2.750 (69.9)	1.982 (50.3)	2.005 (50.9)

APPLICATION NOTES

1. Metric dimensions (mm) are indicated in parentheses.
2. Material: Aluminum alloy with electroless nickel finish.

Dimensions in inches (millimeters) and are subject to change without notice.

TG48
Connector Wrench
MIL-DTL-38999 Series II



TG48 - **20**
 Basic Part Number Dash Number

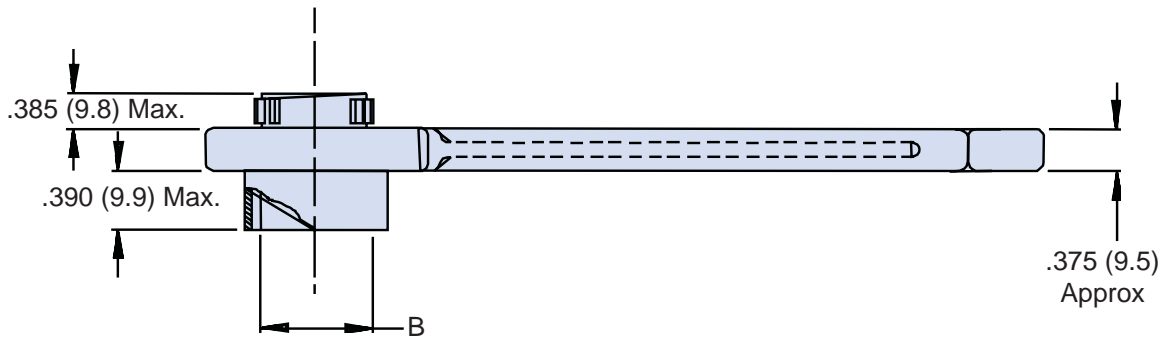
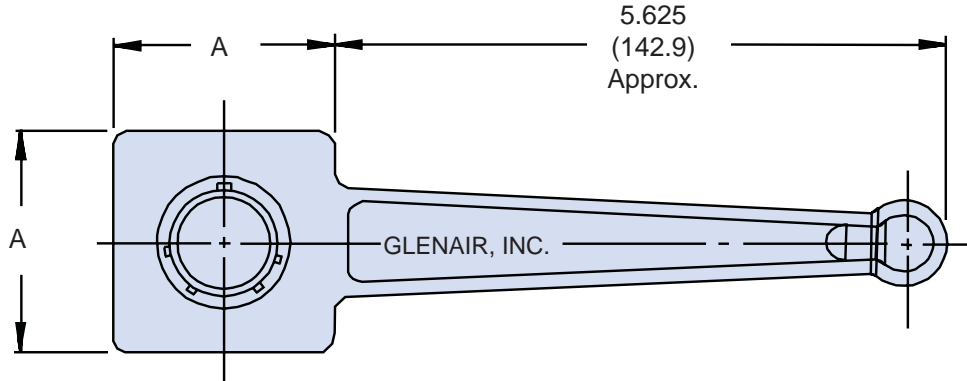

TABLE I: Shell Size and Dimensions

Shell Size	A Dim ± .062 (1.6)	B Dia Ref
8	1.250 (31.8)	.362 (9.2)
10	1.250 (31.8)	.490 (12.4)
12	1.250 (31.8)	.607 (15.4)
14	1.250 (31.8)	.732 (18.6)
16	2.000 (50.8)	.857 (21.8)
18	2.000 (50.8)	.962 (24.4)
20	2.000 (50.8)	1.087 (27.6)
22	2.000 (50.8)	1.212 (30.8)
24	2.000 (50.8)	1.337 (34.0)

APPLICATION NOTES

1. Metric dimensions (mm) are indicated in parentheses.
2. Material: Aluminum alloy with electroless nickel finish.



Dimensions in inches (millimeters) and are subject to change without notice.

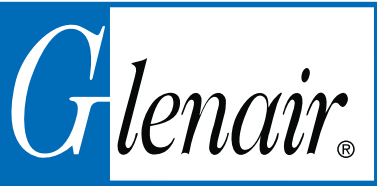

TG52 Connector Wrench MIL-C-81511 Series II & IV

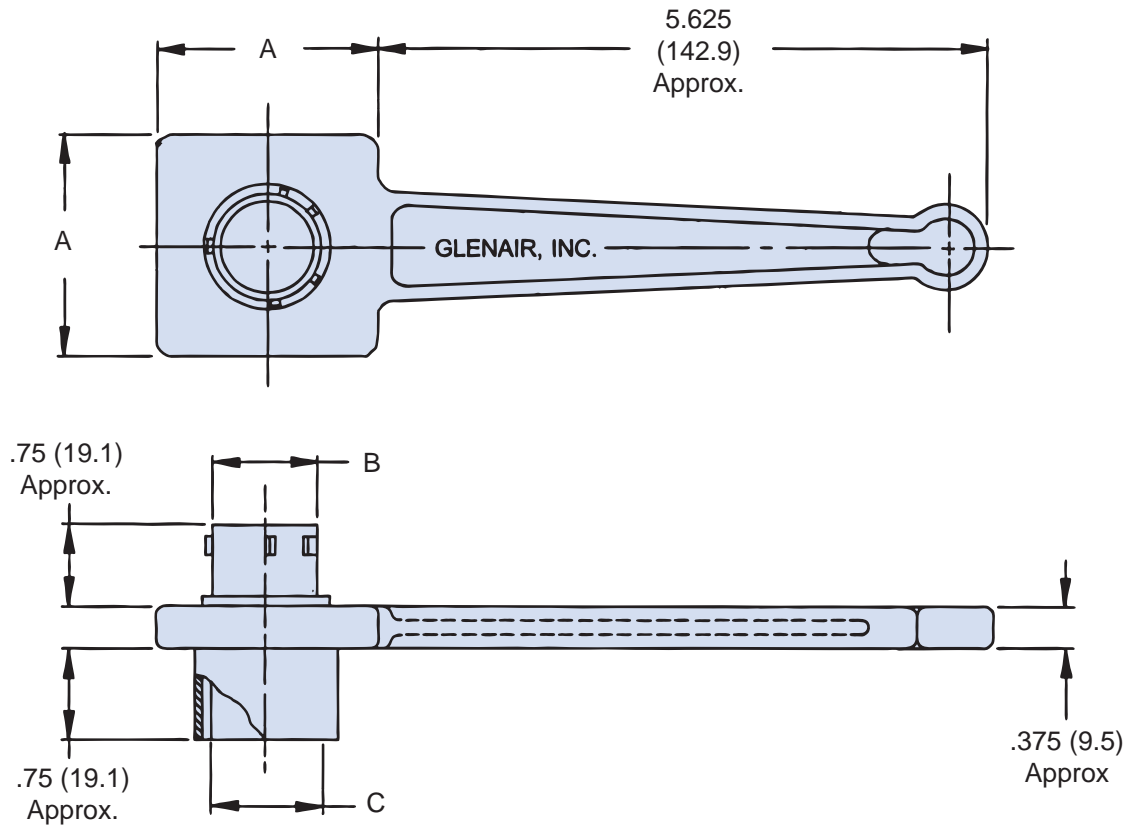
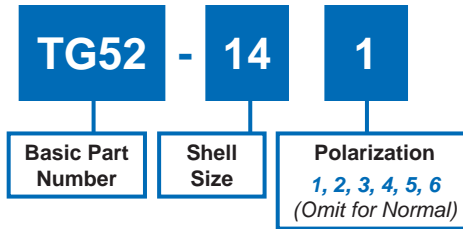

TABLE I: Shell Size and Dimensions

Shell Size	A Dim ± .062 (1.6)	B Dia Ref	C Dia Ref
8	1.250 (31.8)	.382 (9.7)	.386 (9.8)
10	1.250 (31.8)	.507 (12.9)	.511 (13.0)
14	2.000 (50.8)	.757 (19.2)	.761 (19.3)
16	2.000 (50.8)	.883 (22.4)	.887 (22.5)
18	2.000 (50.8)	1.007 (25.6)	1.011 (25.7)

APPLICATION NOTES

1. Metric dimensions (mm) are indicated in parentheses.
2. Material: Aluminum alloy with electroless nickel finish.

Dimensions in inches (millimeters) and are subject to change without notice.

TG60
Connector Wrench
 MIL-DTL-27599, MIL-DTL-38999 Series I



TG60 - 15
 Basic Part Number Shell size

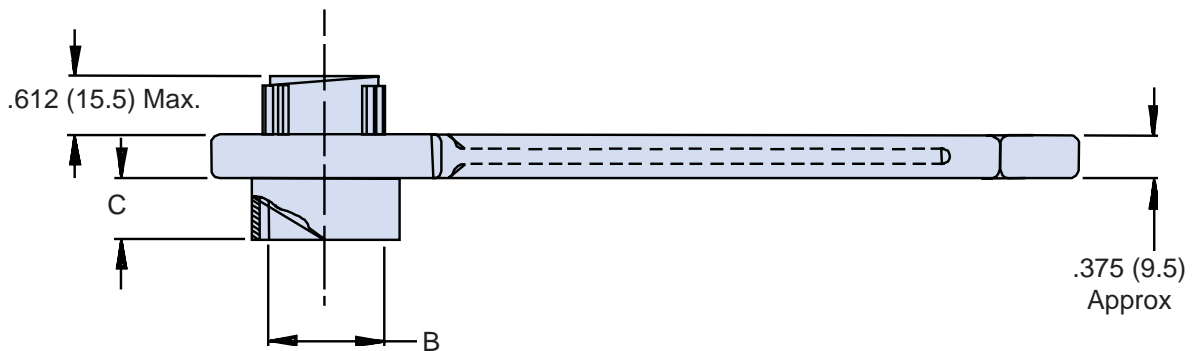
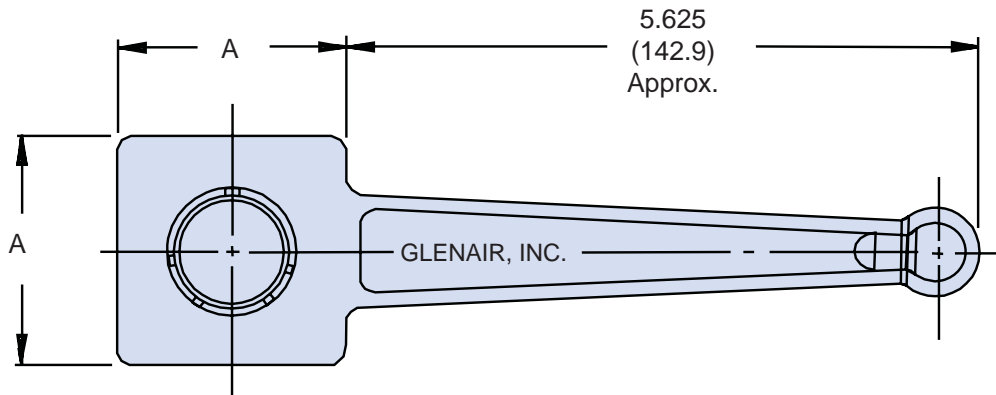

TABLE I: Shell Size and Dimensions

Shell Size	A Dim Ref	B Dia Ref	C Dia Ref
9	1.250 (31.8)	.442 (11.2)	.647 (16.4)
11	1.250 (31.8)	.570 (14.5)	.647 (16.4)
13	1.250 (31.8)	.687 (17.4)	.647 (16.4)
15	2.000 (50.8)	.812 (20.6)	.647 (16.4)
17	2.000 (50.8)	.937 (23.8)	.647 (16.4)
19	2.000 (50.8)	1.042 (26.5)	.647 (16.4)
21	2.000 (50.8)	1.167 (29.6)	.617 (15.7)
23	2.000 (50.8)	1.292 (32.8)	.617 (15.7)
25	2.000 (50.8)	1.417 (36.0)	.617 (15.7)

APPLICATION NOTES

1. Metric dimensions (mm) are indicated in parentheses.
2. Material: Aluminum alloy with electroless nickel finish.

Dimensions in inches (millimeters) and are subject to change without notice.





TG83
Wrench for SJT Connectors
(LN29729)

TG83

20

Basic Part Number

Shell size

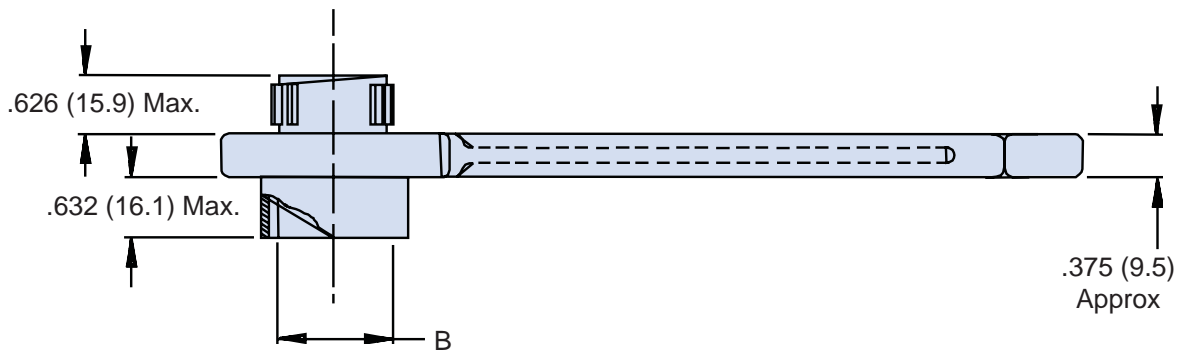
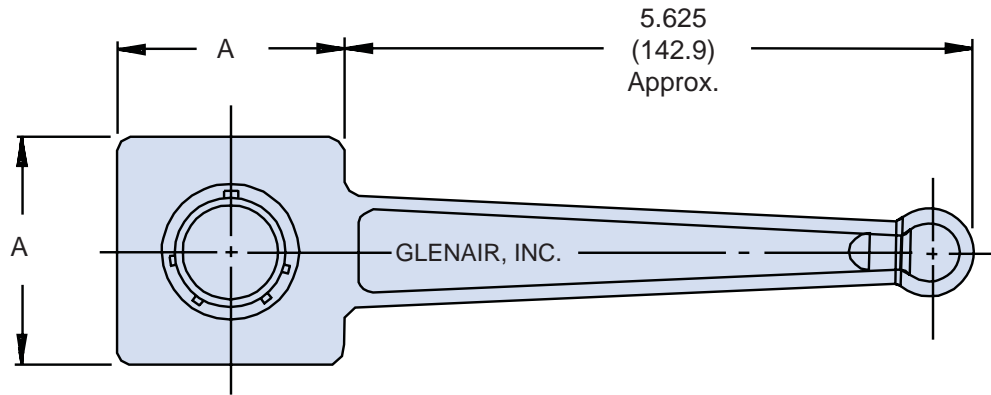

TABLE I: Shell Size and Dimensions

Shell Size	A Dim ± .062 (1.6)	B Dia Ref
8	1.250 (31.8)	.362 (9.2)
10	1.250 (31.8)	.490 (12.4)
12	1.250 (31.8)	.607 (15.4)
14	1.250 (31.8)	.732 (18.6)
16	2.000 (50.8)	.857 (21.8)
18	2.000 (50.8)	.962 (24.4)
20	2.000 (50.8)	1.087 (27.6)
22	2.000 (50.8)	1.212 (30.8)
24	2.000 (50.8)	1.337 (34.0)

APPLICATION NOTES

1. Metric dimensions (mm) are indicated in parentheses.
2. Material: Aluminum alloy with electroless nickel finish.

Dimensions in inches (millimeters) and are subject to change without notice.

TG90
Connector Wrench
MIL-DTL-38999 Series III

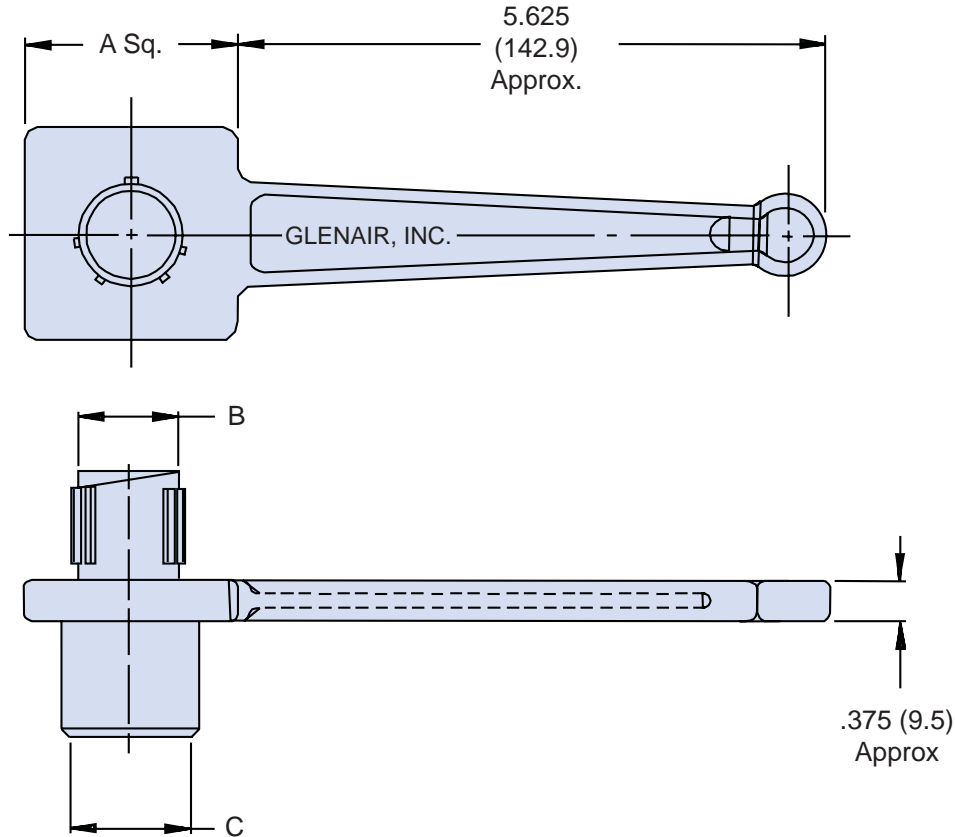
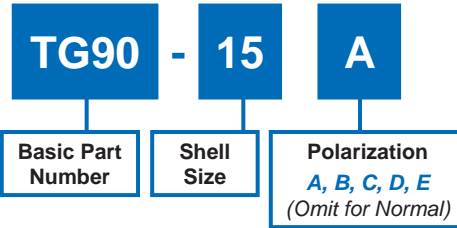

TABLE I: Shell Size and Dimensions

Shell Size	A Dim ± .062 (1.6)	B Dia Ref	C Dia Ref
09	1.250 (31.8)	.438 (11.1)	.441 (11.2)
11	1.250 (31.8)	.566 (14.4)	.569 (14.5)
13	1.250 (31.8)	.678 (17.2)	.682 (17.3)
15	2.000 (50.8)	.802 (20.4)	.811 (20.6)
17	2.000 (50.8)	.928 (23.6)	.931 (23.6)
19	2.000 (50.8)	1.032 (26.2)	1.037 (26.3)
21	2.000 (50.8)	1.155 (29.3)	1.162 (29.5)
23	2.750 (69.9)	1.283 (32.6)	1.288 (32.7)
25	2.750 (69.9)	1.407 (35.7)	1.411 (35.8)

APPLICATION NOTES

- Metric dimensions (mm) are indicated in parentheses.
- Material: Aluminum alloy with electroless nickel finish.



Dimensions in inches (millimeters) and are subject to change without notice.



600B005
Plug and Receptacle Holder
 AS50151 Series AS31001 Solder and Crimp,
 MIL-DTL-83723 Series II

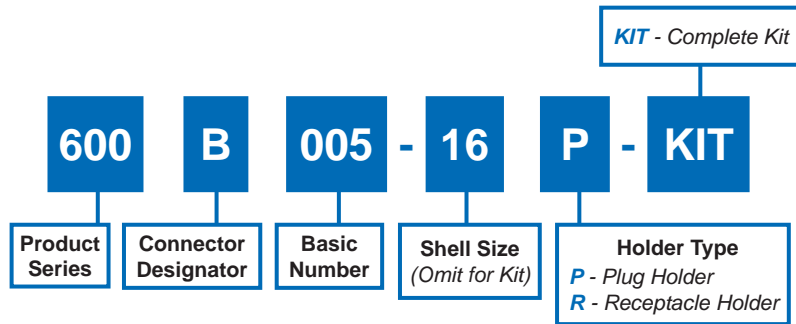

NO POLARIZATION REQUIRED

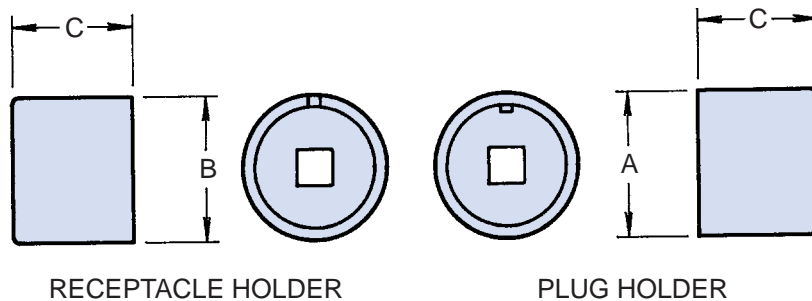

TABLE I: Dash Number, Torque and Dimensions

Dash No.	Torque Max (In/lbs)	A Dia Max	B Dia Max	C Dim Max
08	60	.456 (11.6)	.365 (9.3)	1.250 (31.8)
10	80	.575 (14.6)	.440 (11.2)	1.250 (31.8)
12	110	.691 (17.6)	.555 (14.1)	1.250 (31.8)
14	120	.816 (20.7)	.675 (17.1)	1.250 (31.8)
16	120	.941 (23.9)	.805 (20.4)	1.250 (31.8)
18	120	1.060 (26.9)	.930 (23.6)	1.250 (31.8)
20	140	1.185 (30.1)	1.050 (26.7)	1.250 (31.8)
22	140	1.310 (33.3)	1.175 (29.8)	1.250 (31.8)
24	140	1.435 (36.4)	1.300 (33.0)	1.250 (31.8)
28	150	1.685 (42.8)	1.520 (38.6)	1.250 (31.8)
32	150	1.935 (49.1)	1.777 (45.0)	1.250 (31.8)
36	150	2.177 (55.3)	1.980 (50.3)	1.250 (31.8)

APPLICATION NOTES
1. Also mates with MIL-C-83723, Series II.
2. Metric dimensions (mm) are indicated in parentheses.
3. Material: Case hardened carbon steel with electroless nickel finish.
4. Receptacle and plug holder drives: 1/4" - Shell sizes 08, 10, 12; 3/8" - Shell sizes 14 and up.

Dimensions in inches (millimeters) and are subject to change without notice.

600C005
Plug and Receptacle Holder
 MIL-DTL-22992 Classes C, J & R

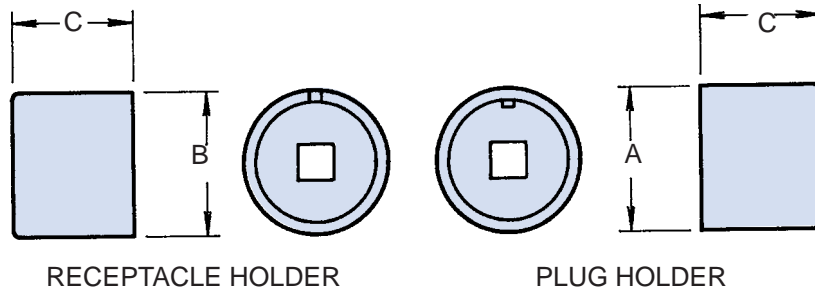
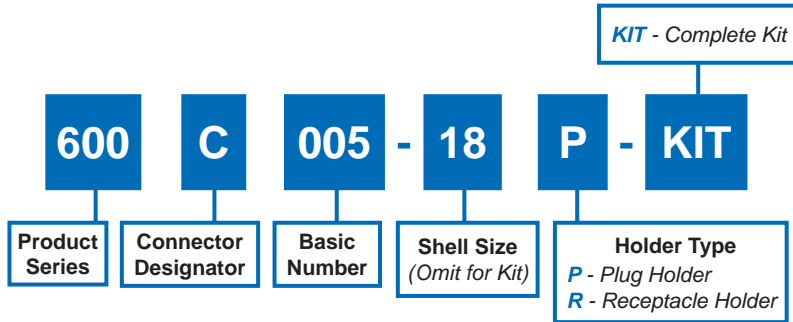

TABLE I: Dash Number, Torque and Dimensions

Dash No.	Torque Max (In/lbs)	A Dia Max	B Dia Max	C Dim Max
12	110	.824 (20.9)	.552 (14.0)	1.280 (32.5)
14	120	.950 (24.1)	.677 (17.2)	1.280 (32.5)
16	120	1.058 (26.9)	.802 (20.4)	1.280 (32.5)
18	120	1.183 (30.0)	.927 (23.5)	1.280 (32.5)
20	140	1.315 (33.4)	1.053 (26.7)	1.280 (32.5)
22	140	1.425 (36.2)	1.177 (29.9)	1.280 (32.5)
24	140	1.683 (42.7)	1.302 (33.1)	1.280 (32.5)
28	150	1.931 (49.0)	1.521 (38.6)	1.280 (32.5)
32	150	2.183 (55.4)	1.771 (45.0)	1.280 (32.5)
36	150	2.445 (62.1)	1.990 (50.5)	1.280 (32.5)

APPLICATION NOTES

1. Metric dimensions (mm) are indicated in parentheses.
2. Material: Case hardened carbon steel with electroless nickel finish.
3. Receptacle and plug holder drives: 1/4" - Shell size 12; 3/8" - Shell sizes 14 and up.
4. Consult Factory for larger sizes.

Dimensions in inches (millimeters) and are subject to change without notice.



600D005
Plug and Receptacle Holder
 MIL-DTL-26482 Series I & II,
 MIL-DTL-83723 Series I and NAS 1599

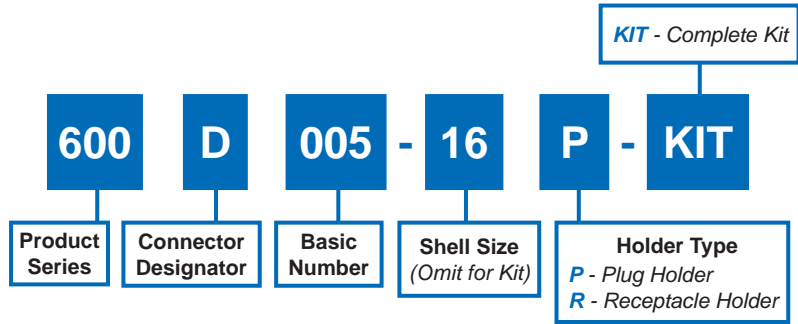

NO POLARIZATION REQUIRED

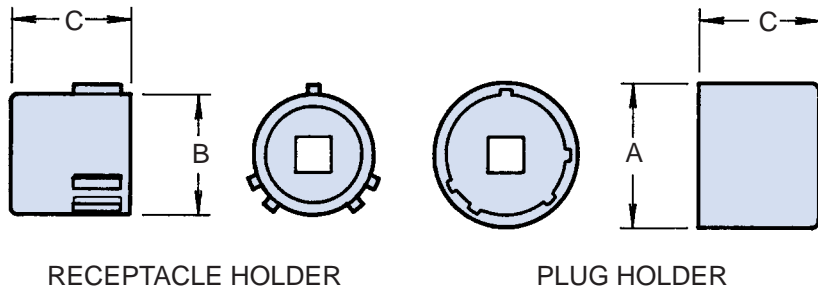

RECEPTACLE HOLDER

PLUG HOLDER

TABLE I: Dash Number, Torque and Dimensions

Dash No.	Torque Max (In/lbs)		A Dia Max	B Dia Max	C Dim Max
	Series I	Series II			
08	40	60	.478 (12.1)	.358 (9.1)	.910 (23.1)
10	40	80	.599 (15.2)	.486 (12.3)	.910 (23.1)
12	40	110	.758 (19.3)	.598 (15.2)	.910 (23.1)
14	40	120	.882 (22.4)	.723 (18.4)	.910 (23.1)
16	40	120	1.007 (25.6)	.848 (21.5)	.910 (23.1)
18	40	120	1.133 (28.8)	.948 (24.1)	.910 (23.1)
20	80	140	1.257 (31.9)	1.073 (27.3)	.910 (23.1)
22	80	140	1.382 (35.1)	1.198 (30.4)	.910 (23.1)
24	80	140	1.507 (38.3)	1.323 (33.6)	.910 (23.1)

APPLICATION NOTES

1. Also mates with MIL-C-83723, Series I; 40M39569.
2. Metric dimensions (mm) are indicated in parentheses.
3. Material: Case hardened carbon steel with electroless nickel finish.
4. Receptacle and plug holder drives: 1/4" - Shell sizes 08, 10, 12; 3/8" - Shell sizes 14 and up.

Dimensions in inches (millimeters) and are subject to change without notice.

600E005
Plug and Receptacle Holder
MIL-DTL-26500 and MIL-DTL-83723 Series III

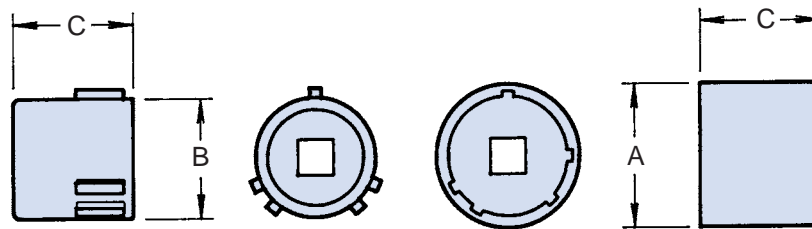
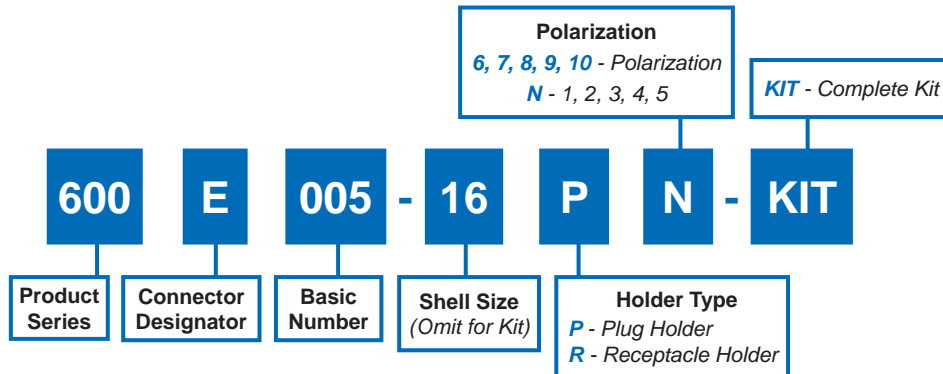

RECEPTACLE HOLDER

PLUG HOLDER

TABLE I: Dash Number, Torque and Dimensions

Dash No.	Torque Max (In/lbs)	A Dia Max	B Dia Max	C Dim Max
08	60	.537 (13.6)	.424 (10.8)	1.031 (26.2)
10	80	.660 (16.8)	.526 (13.4)	1.031 (26.2)
12	110	.830 (21.1)	.696 (17.7)	1.031 (26.2)
14	120	.899 (22.8)	.765 (19.4)	1.031 (26.2)
16	120	1.026 (26.1)	.892 (22.7)	1.031 (26.2)
18	120	1.132 (28.8)	.998 (25.3)	1.031 (26.2)
20	140	1.259 (32.0)	1.123 (28.6)	1.031 (26.2)
22	140	1.382 (35.1)	1.248 (31.7)	1.031 (26.2)
24	140	1.509 (38.3)	1.373 (34.9)	1.031 (26.2)
28*	150	1.740 (44.2)	1.623 (41.2)	1.031 (26.2)

* Non-Military standard shell size

APPLICATION NOTES

1. Metric dimensions (mm) are indicated in parentheses.
2. Material: Case hardened carbon steel with electroless nickel finish.
3. Receptacle and plug holder drives: 1/4" - Shell sizes 08, 10, 12; 3/8" - Shell sizes 14 and up.

Dimensions in inches (millimeters) and are subject to change without notice.



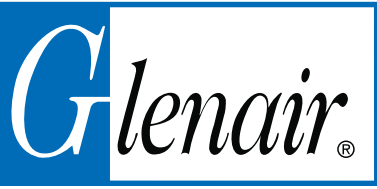

600F005
Plug and Receptacle Holder
 MIL-DTL-27599, MIL-DTL-38999 Series I

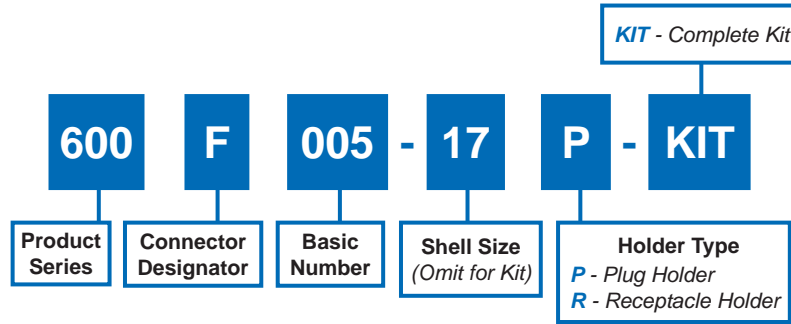

NO POLARIZATION REQUIRED

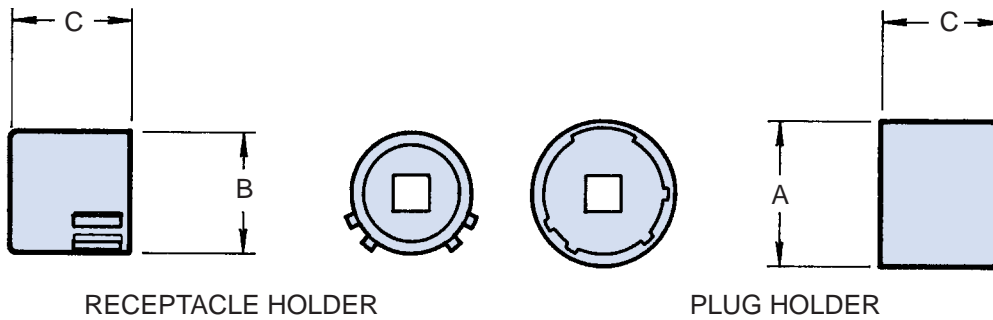

TABLE I: Dash Number, Torque and Dimensions

Dash No.	Torque Max (In/lbs)	A Dia Max	B Dia Max	C Dim Max
09	40	.577 (14.7)	.438 (11.1)	1.031 (26.2)
11	40	.709 (18.0)	.566 (14.4)	1.031 (26.2)
13	40	.829 (21.1)	.678 (17.2)	1.031 (26.2)
15	40	.954 (24.2)	.803 (20.4)	1.031 (26.2)
17	40	1.107 (28.1)	.928 (23.6)	1.031 (26.2)
19	40	1.190 (30.2)	1.033 (26.2)	1.031 (26.2)
21	80	1.315 (33.4)	1.158 (29.4)	1.031 (26.2)
23	80	1.440 (36.6)	1.283 (32.6)	1.031 (26.2)
25	80	1.565 (39.8)	1.408 (35.8)	1.031 (26.2)

APPLICATION NOTES
1. Metric dimensions (mm) are indicated in parentheses.
2. Material: Case hardened carbon steel with electroless nickel finish.
3. Receptacle and plug holder drives: 1/4" - Shell sizes 08, 10, 12; 3/8" - Shell sizes 14 and up.

Dimensions in inches (millimeters) and are subject to change without notice.

600FF005
Plug and Receptacle Holder
MIL-DTL-38999 Series II

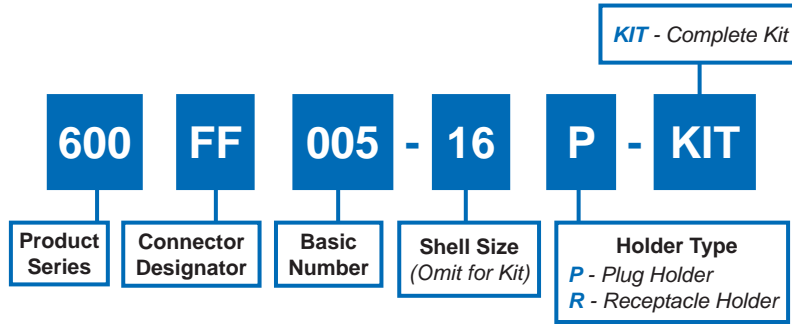

NO POLARIZATION REQUIRED

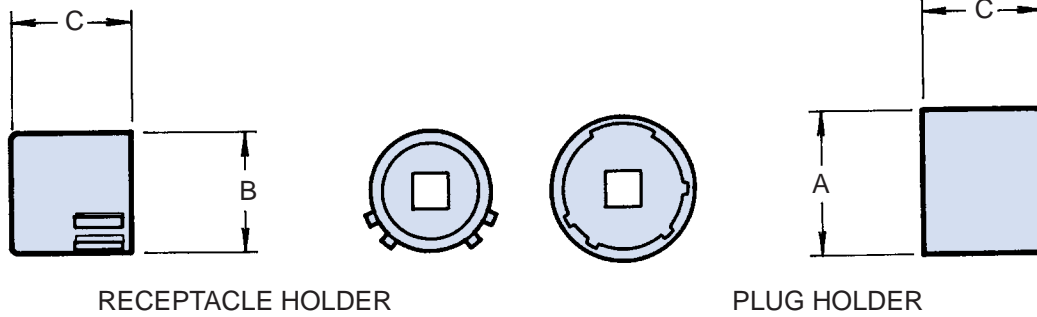

TABLE I: Dash Number, Torque and Dimensions

Dash No.	Torque Max (In/lbs)	A Dia Max	B Dia Max	C Dim Max
08	40	.478 (12.1)	.358 (9.1)	.910 (23.1)
10	40	.599 (15.2)	.486 (12.3)	.910 (23.1)
12	40	.758 (19.3)	.603 (15.3)	.910 (23.1)
14	40	.882 (22.4)	.728 (18.5)	.910 (23.1)
16	40	1.007 (25.6)	.853 (21.7)	.910 (23.1)
18	40	1.133 (28.8)	.958 (24.3)	.910 (23.1)
20	80	1.257 (31.9)	1.083 (27.5)	.910 (23.1)
22	80	1.382 (35.1)	1.208 (30.7)	.910 (23.1)
24	80	1.507 (38.3)	1.333 (33.9)	.910 (23.1)

APPLICATION NOTES
1. Also mates with 40M38277.
2. Metric dimensions (mm) are indicated in parentheses.
3. Material: Case hardened carbon steel with electroless nickel finish.
4. Receptacle and plug holder drives: 1/4" - Shell sizes 08, 10, 12; 3/8" - Shell sizes 14 and up.

Dimensions in inches (millimeters) and are subject to change without notice.



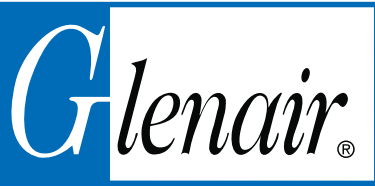

600G005 Plug and Receptacle Holder MIL-DTL-28840

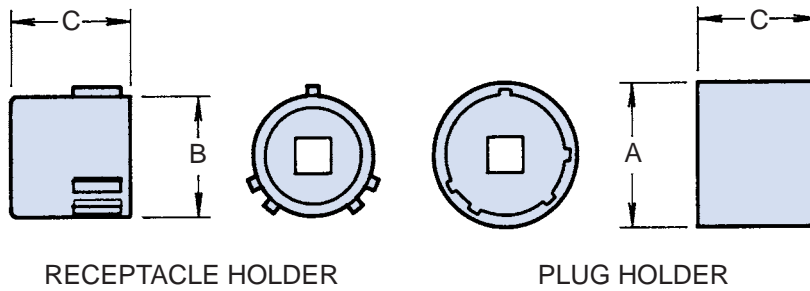
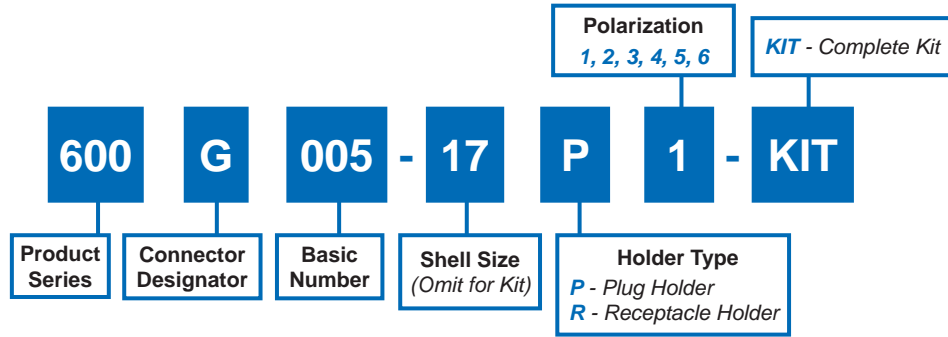

TABLE I: Dash Number, Torque and Dimensions

Dash No.	Torque Max (In/lbs)	A Dia Max	B Dia Max	C Dim Max
11	80	.697 (17.7)	.502 (12.8)	.945 (24.0)
13	110	.822 (20.8)	.626 (15.9)	.945 (24.0)
15	120	.995 (25.3)	.798 (20.3)	.945 (24.0)
17	120	1.058 (26.9)	.868 (22.0)	.945 (24.0)
19	120	1.245 (31.6)	1.035 (26.3)	.945 (24.0)
23	140	1.433 (36.4)	1.220 (31.0)	.945 (24.0)
25	140	1.558 (39.6)	1.381 (35.1)	.945 (24.0)
29	150	1.745 (44.3)	1.547 (39.3)	.945 (24.0)
33	150	1.933 (49.1)	1.739 (44.2)	.945 (24.0)

APPLICATION NOTES
1. Metric dimensions (mm) are indicated in parentheses.
2. Material: Case hardened carbon steel with electroless nickel finish.
3. Receptacle and plug holder drives: 1/4" - Shell sizes 08, 10, 12; 3/8" - Shell sizes 14 and up.

Dimensions in inches (millimeters) and are subject to change without notice.

H

600H005
Plug and Receptacle Holder
MIL-DTL-38999 Series III

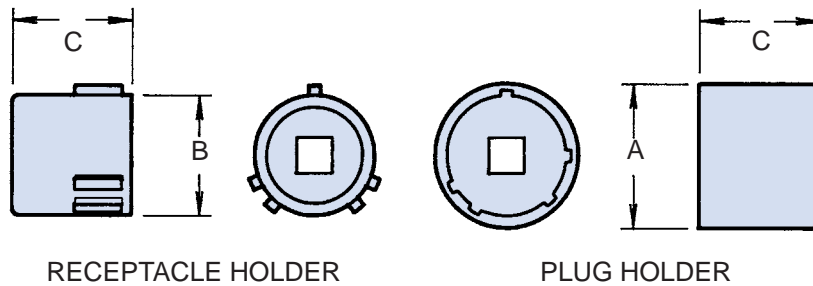
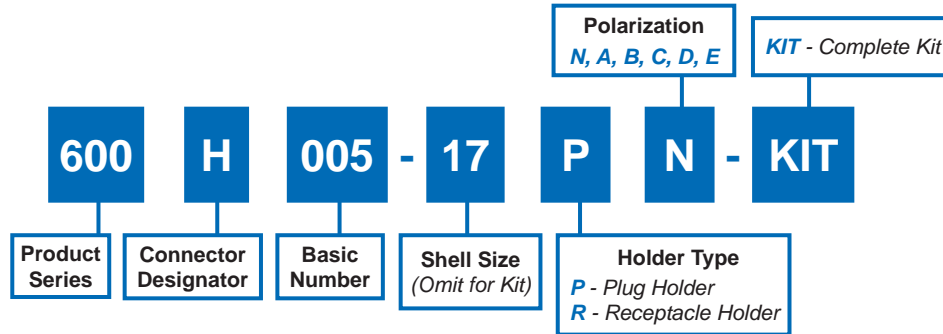

RECEPTACLE HOLDER

PLUG HOLDER

TABLE I: Dash Number, Torque and Dimensions

Shell Size	Commercial	Military Ref	Max Torque (± 5 Inch Lbs)		A Dia Max	B Dia Max	C Dim Max
			Metal	Composite			
09		A	60	35	.577 (14.7)	.438 (11.1)	1.031 (26.2)
11		B	80	35	.709 (18.0)	.566 (14.4)	1.031 (26.2)
13		C	110	40	.829 (21.1)	.678 (17.2)	1.031 (26.2)
15		D	120	40	.954 (24.2)	.803 (20.4)	1.031 (26.2)
17		E	120	40	1.107 (28.1)	.928 (23.6)	1.031 (26.2)
19		F	120	40	1.190 (30.2)	1.033 (26.2)	1.031 (26.2)
21		G	140	80	1.315 (33.4)	1.158 (29.4)	1.031 (26.2)
23		H	140	80	1.440 (36.6)	1.283 (32.6)	1.031 (26.2)
25		J	140	80	1.565 (39.8)	1.408 (35.8)	1.031 (26.2)

APPLICATION NOTES

1. Metric dimensions (mm) are indicated in parentheses.
2. Material: Case hardened carbon steel with electroless nickel finish.
3. Receptacle and plug holder drives:
 1/4" - Shell sizes 08, 10, 12; 3/8" - Shell sizes 14 and up.
4. Composite values apply when using Glenair 600-091, 600-157 or 600-007 tools.

Dimensions in inches (millimeters) and are subject to change without notice.



600HH005 Plug and Receptacle Holder MIL-DTL-38999 Series IV

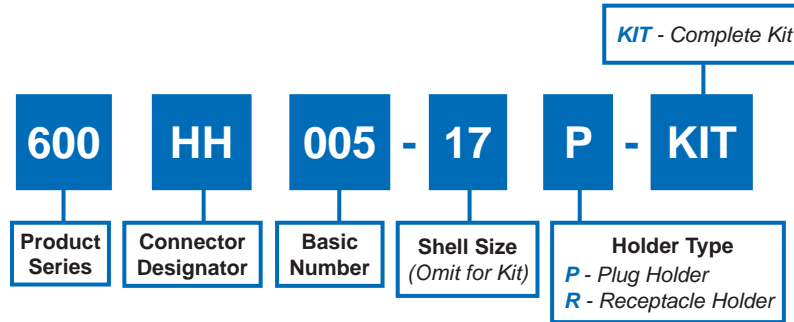

NO POLARIZATION REQUIRED

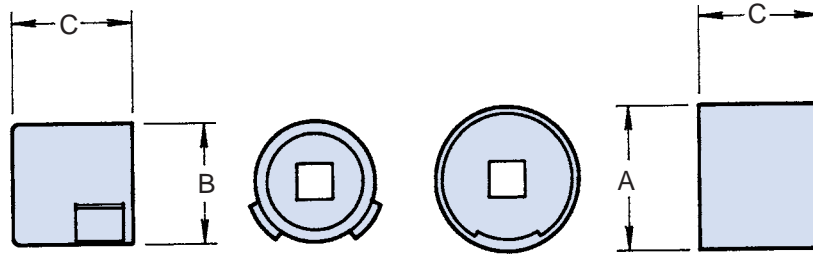

PLUG HOLDER

RECEPTACLE HOLDER

TABLE I: Dash Number, Torque and Dimensions

Shell Size		Max Torque (Inch Pounds)	A Dia Max	B Dia Max	C Dim Max
Commercial	Military Ref				
11	B	80	.830 (21.1)	.515 (13.1)	1.280 (32.5)
13	C	110	.950 (24.1)	.650 (16.5)	1.280 (32.5)
15	D	120	1.070 (27.2)	.775 (19.7)	1.280 (32.5)
17	E	120	1.200 (30.5)	.901 (22.9)	1.280 (32.5)
19	F	120	1.280 (32.5)	1.015 (25.8)	1.280 (32.5)
21	G	140	1.400 (35.6)	1.140 (29.0)	1.280 (32.5)
23	H	140	1.530 (38.9)	1.265 (32.1)	1.280 (32.5)
25	J	140	1.660 (42.2)	1.392 (35.4)	1.280 (32.5)

APPLICATION NOTES

- Metric dimensions (mm) are indicated in parentheses.
- Material: Case hardened carbon steel with electroless nickel finish.
- Receptacle and plug holder drives: 1/4" - Shell sizes 11 and 13; 3/8" - Shell sizes 15 and up.

Dimensions in inches (millimeters) and are subject to change without notice.

600J005
Plug and Receptacle Holder
MIL-DTL-81511 Series I, II, III & IV

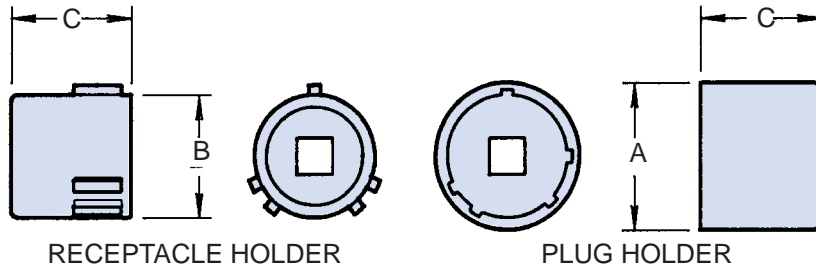
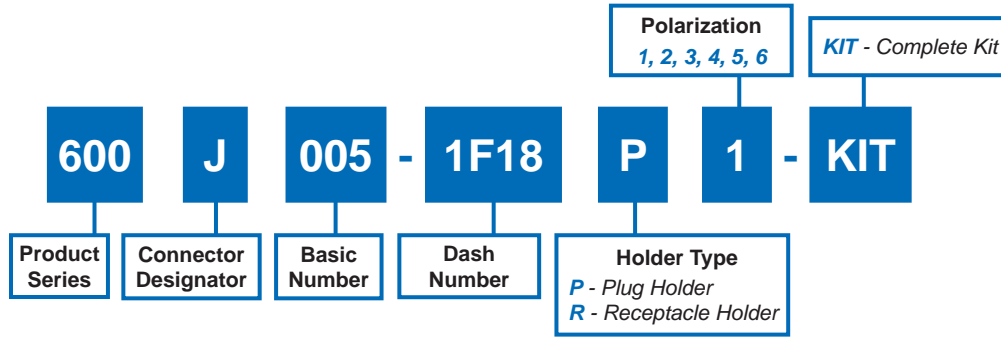

SERIES I and III: Dash Number, Shell Size, Torque and Dimensions

Dash Number	Shell Size		Max Torque (± 5 Inch Lbs)	A Dia Max	B Dia Max	C Dim Max
	Commercial	Military Ref				
1A08	08	A	40	.556 (14.1)	.394 (10.0)	.950 (24.1)
1B10	10	B	40	.681 (17.3)	.519 (13.2)	.950 (24.1)
1D14	14	D	40	.931 (23.6)	.769 (19.5)	.950 (24.1)
1E16	16	E	40	1.058 (26.9)	.895 (22.7)	.950 (24.1)
1F18	18	F	40	1.181 (30.0)	1.019 (25.9)	.950 (24.1)
1G20	20	G	40	1.306 (33.2)	1.144 (29.1)	.950 (24.1)
1H22	22	H	40	1.431 (36.3)	1.269 (32.2)	.950 (24.1)
1J24	24	J	40	1.556 (39.5)	1.394 (35.4)	.950 (24.1)

SERIES II and IV: Dash Number, Shell Size, Torque and Dimensions

Dash Number	Shell Size		Max Torque (± 5 Inch Lbs)	A Dia Max	B Dia Max	C Dim Max
	Commercial	Military Ref				
2A08	08	A	40	.544 (13.8)	.374 (9.5)	.950 (24.1)
2B10	10	B	40	.669 (17.0)	.499 (12.7)	.950 (24.1)
2D14	14	D	40	.919 (23.3)	.749 (19.0)	.950 (24.1)
2E16	16	E	40	1.045 (26.5)	.875 (22.2)	.950 (24.1)
2F18	18	F	40	1.169 (29.7)	.999 (25.4)	.950 (24.1)

APPLICATION NOTES

1. Metric dimensions (mm) are indicated in parentheses.
2. Material: Case hardened carbon steel with electroless nickel finish.
3. Receptacle and plug holder drives:
 1/4" - Shell sizes 08, 10 and 12; 3/8" - Shell sizes 14 and up.



Dimensions in inches (millimeters) and are subject to change without notice.

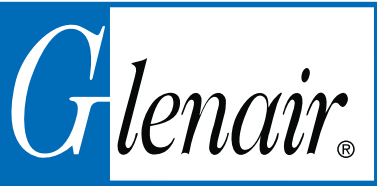

TG90 Connector Wrench MIL-DTL-38999 Series III

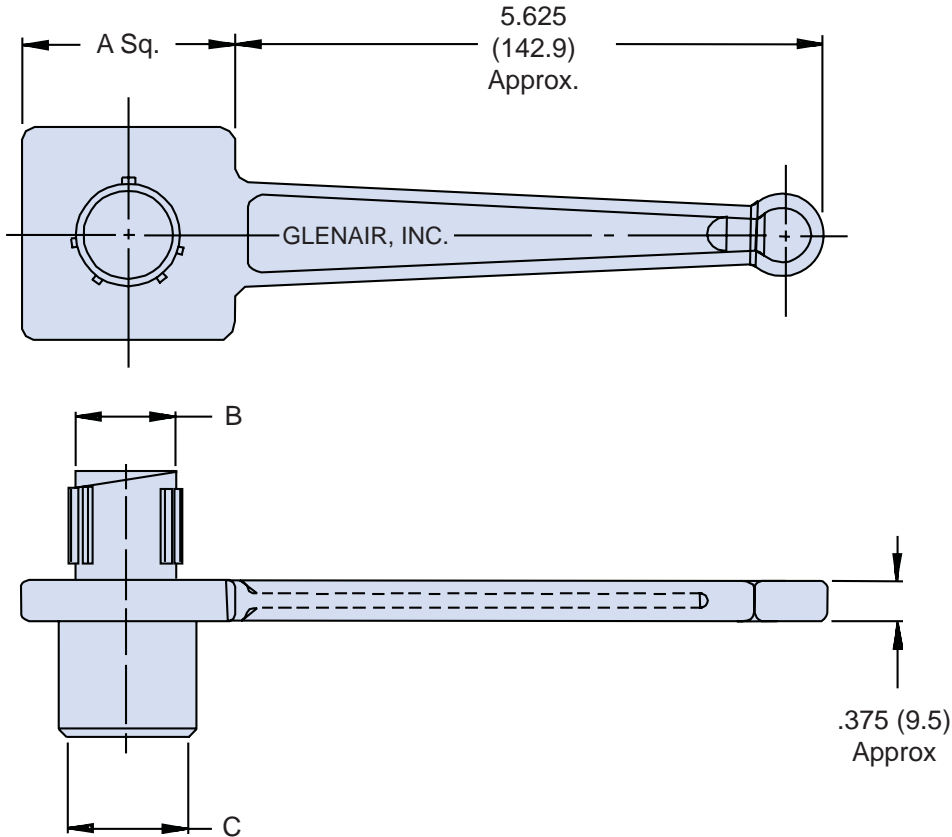
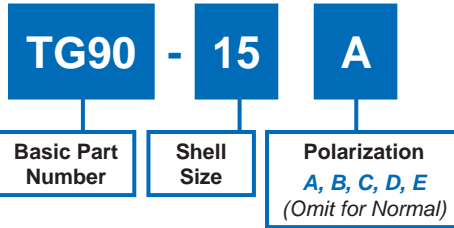

TABLE I: Shell Size and Dimensions

Shell Size	A Dim ± .062 (1.6)	B Dia Ref	C Dia Ref
09	1.250 (31.8)	.438 (11.1)	.441 (11.2)
11	1.250 (31.8)	.566 (14.4)	.569 (14.5)
13	1.250 (31.8)	.678 (17.2)	.682 (17.3)
15	2.000 (50.8)	.802 (20.4)	.811 (20.6)
17	2.000 (50.8)	.928 (23.6)	.931 (23.6)
19	2.000 (50.8)	1.032 (26.2)	1.037 (26.3)
21	2.000 (50.8)	1.155 (29.3)	1.162 (29.5)
23	2.750 (69.9)	1.283 (32.6)	1.288 (32.7)
25	2.750 (69.9)	1.407 (35.7)	1.411 (35.8)

APPLICATION NOTES

1. Metric dimensions (mm) are indicated in parentheses.
2. Material: Aluminum alloy with electroless nickel finish.

Dimensions in inches (millimeters) and are subject to change without notice.

Military Standard Backshells and Accessories Quick-Reference Part Number to Page Number Index



Part Number	Page
AS25042	G-2
AS25043	
AS50151	G-8
AS81511/13	F-2
AS81511/14	F-3
AS81511/14	F-5
AS81511/17	F-7
AS81511/18	
AS81511/19	F-8
AS81511/20	F-9
AS81511/29	F-7
AS81511/30	F-10
AS85049/1	B-2
AS85049/2	B-3
AS85049/3	B-4 B-5 B-6
AS85049/4	B-7 B-9 B-11
AS85049/5	B-13 B-15 B-17
AS85049/6	B-19
AS85049/7	B-21
AS85049/8	B-23
AS85049/9	B-25
AS85049/10	B-27
AS85049/11	B-31
AS85049/14	B-35
AS85049/15	B-36
AS85049/16	B-36
AS85049/17	B-37
AS85049/18	B-38
AS85049/19	B-39
AS85049/20	B-41
AS85049/21	B-42
AS85049/23	B-43
AS85049/24	B-45
AS85049/25	B-47
AS85049/26	B-51 B-52
AS85049/27	B-53
AS85049/28	B-54

Part Number	Page
AS85049/29	B-55
AS85049/30	B-56
AS85049/31	B-57
AS85049/33	B-58
AS85049/34	B-59
AS85049/36	B-60
AS85049/37	B-61
AS85049/38	B-62
AS85049/39	B-63
AS85049/41	B-64
AS85049/42	B-65
AS85049/43	B-66
AS85049/44	B-67
AS85049/45	B-68
AS85049/46	B-69
AS85049/47	B-70
AS85049/48	B-71 B-72 B-73
AS85049/49	B-74
AS85049/50	B-75
AS85049/51	B-76
AS85049/52	B-77
AS85049/53	B-78
AS85049/54	
AS85049/55	
AS85049/56	B-79
AS85049/57	
AS85049/58	B-80
AS85049/59	B-81
AS85049/60	B-82 B-83
AS85049/61	B-84
AS85049/62	B-85
AS85049/63	B-86
AS85049/69	B-87
AS85049/74	B-88
AS85049/75	B-89
AS85049/76	B-90
AS85049/77	B-91
AS85049/78	B-92
AS85049/79	B-93
AS85049/80	B-94

Part Number	Page
AS85049/81	B-96
AS85049/82	B-97
AS85049/83	
AS85049/84	
AS85049/85	B-99
AS85049/86	
AS85049/87	
AS85049/88	B-101
AS85049/89	
AS85049/90	
AS85049/91	B-103
AS85049/92	
AS85049/93	B-104
AS85049/94	B-105
AS85049/95	B-106
AS85049/96	B-107
AS85049/103	B-108
AS85049/104	B-110
AS85049/105	B-112
AS85049/109	B-114
AS85049/111	B-116
AS85049/112	B-118
AS85049/114	B-120
AS85049/115	B-122
AS85049/118	B-124
AS85049/120	B-126
AS85049/121	B-128
AS85049/123	B-130
AS85049/124	B-132
AS85049/126	B-134
AS85049/127	B-136
AS85049/128-3	B-137
AS85049/128-4	
AS85049/130	B-138
AS85049/139	B-140
AS85049/140	B-142 B-144 B-146 B-148
AS85049/141	B-150 B-152 B-154
AS85049/142	B-156 B-158 B-160

Part Number	Page
MIL-DTL-26500	G-5
MIL-DTL-26500	G-6
MIL-DTL-28840/1	D-2
MIL-DTL-28840/2	D-3
MIL-DTL-28840/3	D-4
MIL-DTL-28840/4	D-5
MIL-DTL-28840/5	D-6
MIL-DTL-28840/6	D-7 D-8
MIL-DTL-28840/7	D-9
MIL-DTL-28840/8	D-10 D-11
MIL-DTL-28840/9	D-12 D-13
MIL-DTL-28840/13	D-14
MIL-DTL-28840/15	
MIL-DTL-28840/22	D-15
MIL-DTL-28840/23	D-16
MIL-DTL-28840/24	D-17
MIL-DTL-38999	C-2
MIL-DTL-38999	
MIL-DTL-38999	C-3
MIL-DTL-38999/22	C-4
MIL-DTL-38999/28	C-5
MIL-DTL-38999/32	C-6
MIL-DTL-38999/33	
MIL-DTL-38999/50	C-7
MIL-DTL-83513/05	G-15
MIL-DTL-83538/9	G-16
MIL-DTL-83723/27	E-2
MIL-DTL-83723/35	E-3 E-4 E-5
MIL-DTL-83723/50	E-6
MIL-DTL-83723/59	E-7
MIL-DTL-83723/60	
MIL-DTL-83723/59	E-8
MIL-DTL-83723/60	
MIL-DTL-83723/70	E-9
MIL-S-81824/1	G-17
MS17349	G-3
MS17350	
MS27291	G-4

Dimensions in inches (millimeters) and are subject to change without notice.



Out of This World
**INTERCONNECT
SOLUTIONS**

Glenair, Inc.

1211 Air Way • Glendale, California • 91201-2497
Telephone: 818-247-6000 • Fax: 818-500-9912 • sales@glenair.com
www.glenair.com

**Glenair Power
Products Group**

860 N. Main Street Extension
Wallingford, CT
06492

Telephone:
203-741-1115
Facsimile:
203-741-0053
sales@glenair.com

Glenair UK Ltd

40 Lower Oakham Way
Oakham Business Park
P.O. Box 37, Mansfield
Notts, NG18 5BY England

Telephone:
+44-1623-638100
Facsimile:
+44-1623-638111
sales@glenair.co.uk

Glenair Microway Systems

7000 North Lawndale Avenue
Lincolnwood, IL
60712

Telephone:
847-679-8833
Facsimile:
847-679-8849

Glenair Nordic AB

Gustav III : S Boulevard 46
S - 169 27 Solna
Sweden

Telephone:
+46-8-50550000
Facsimile:
+46-8-50550001
sales@glenair.se

Glenair Electric GmbH

Schaberweg 28
61348 Bad Homburg
Germany

Telephone:
06172 / 68 16 0
Facsimile:
06172 / 68 16 90
germany@glenair.com

Glenair Iberica

C/ La Vega, 16
45612 Velada
Spain

Telephone:
+34-925-89-29-88
Facsimile:
+34-925-89-29-87
sales@glenair.es

Glenair Italia S.p.A.

Via Del Lavoro, 7
40057 Quarto Inferiore –
Granarolo dell'Emilia
Bologna, Italy

Telephone:
+39-051-782811
Facsimile:
+39-051-782259
info@glenair.it

Glenair France SARL

7, Avenue Parmentier
Immeuble Central Parc #2
31200 Toulouse
France

Telephone:
+33-5-34-40-97-40
Facsimile:
+33-5-61-47-86-10
sales@glenair.fr

