

A

CONNECTOR DESIGNATOR:	
A	MIL-DTL-5015, -26482 Series II, and -83723 Series I and III
F	MIL-DTL-38999 Series I, II
H	MIL-DTL-38999 Series III and IV
SELF-LOCKING	
ROTATABLE COUPLING	
LOW PROFILE	

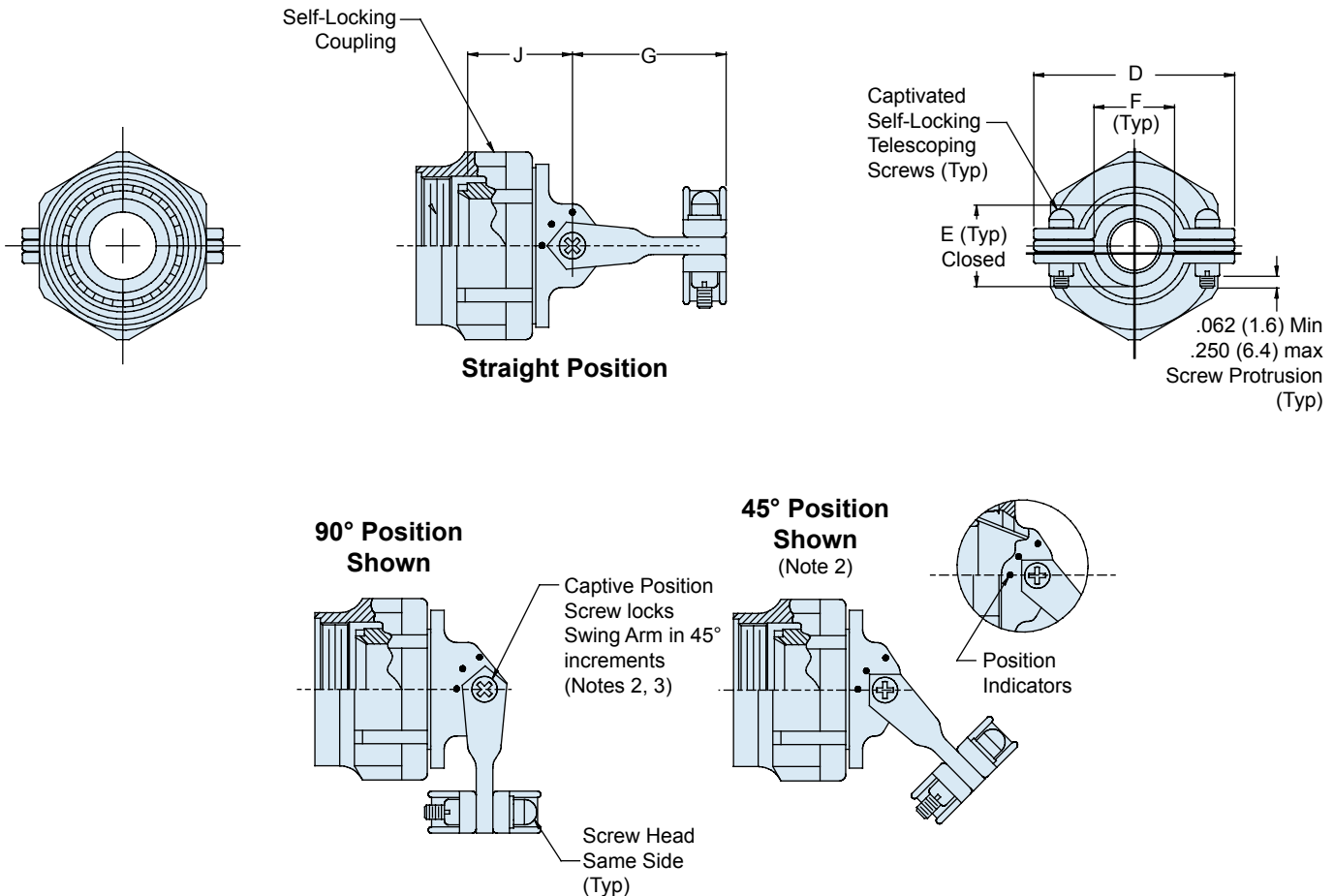
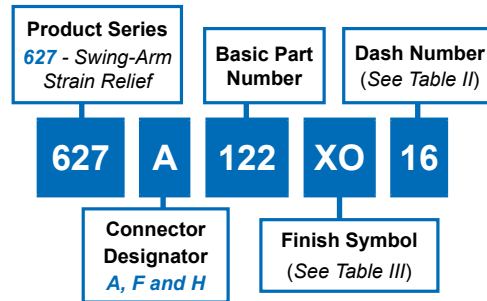

U.S. PATENT NO. 6419519

627-122 Composite Swing-Arm Strain Relief with Self-Locking Rotatable Coupling



Composite
Backshells

A

TABLE II: CONNECTOR SHELL SIZE ORDER NUMBER

Shell Size for Connector Designator*			E	F	G	H	J
A	F	H	±.06 (1.5)	Min	Max	Max	±.03 0.8
08	08	09	.265 (6.7)	.220 (5.9)	1.060 (26.9)	.980 (24.9)	.880 (22.4)
10	10	11	.310 (7.9)	.270 (6.9)	1.090 (27.7)	1.050 (26.7)	.910 (23.1)
12	12	13	.390 (9.9)	.350 (8.9)	1.180 (30.0)	1.200 (30.5)	.950 (24.1)
14	14	15	.506 (12.9)	.470 (11.9)	1.240 (31.5)	1.300 (33.0)	1.010 (25.7)
16	16	17	.591 (15.0)	.550 (14.0)	1.320 (33.5)	1.440 (36.6)	1.050 (26.7)
18	18	19	.661 (16.8)	.620 (15.7)	1.390 (35.3)	1.560 (39.6)	1.080 (30.0)
20	20	21	.744 (18.9)	.700 (17.8)	1.550 (39.4)	1.690 (42.9)	1.120 (28.4)
22	22	23	.826 (21.0)	.780 (19.8)	1.550 (39.4)	1.770 (45.0)	1.160 (29.5)
24	24	25	.896 (22.8)	.850 (21.6)	1.610 (40.9)	1.890 (48.0)	1.200 (30.5)

TABLE III: FINISH

Symbol	Finish Description
XB	No Plating - Black Color (Non-Conductive Finish)
XO	No Plating - Brown Color (Non-Conductive Finish)

APPLICATION NOTES

- Metric dimensions (mm) are in parentheses and are for reference only.
- Glenair series 600 Backshell assembly Tools are recommended for assembly and installation.
- Swing Arm locks in 45° increments— Sizes 08 thru 24, additional positioning increments are manufacturer's option.
- Captive Screw can remain engaged to the body when positioning the Arm. When tightened, the Screw shall not protrude into the inside surfaces.
- Coupling nut supplied unplated.
- Consult factory for additional entry sizes available.
- See Table I in Intro for front-end dimensional details.