



**319-064**  
**Composite Self-Locking Rotatable Coupling**  
 Swing-Arm Strain Relief with  
 Nickel/Copper EMI/RFI Shield Sock & Optional Split Ring

**CONNECTOR  
 DESIGNATOR**

MIL-DTL-38999 Series I, II (F)  
 (for Series II see note 6)  
 MIL-DTL-38999 Series III and IV (H)

**F-H**

**SELF-LOCKING**

**ROTATABLE  
 COUPLING**

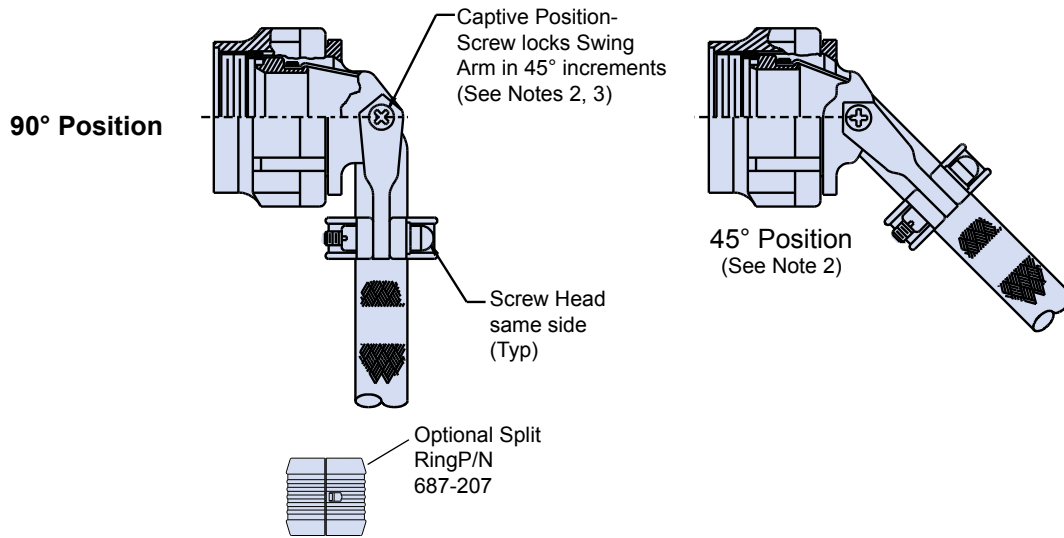
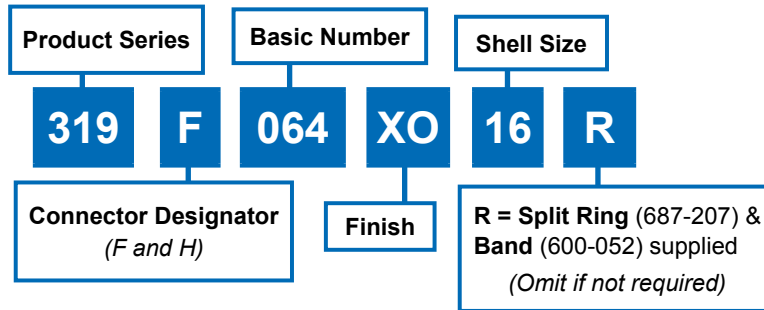

**U.S. PATENT NO. 6419519**

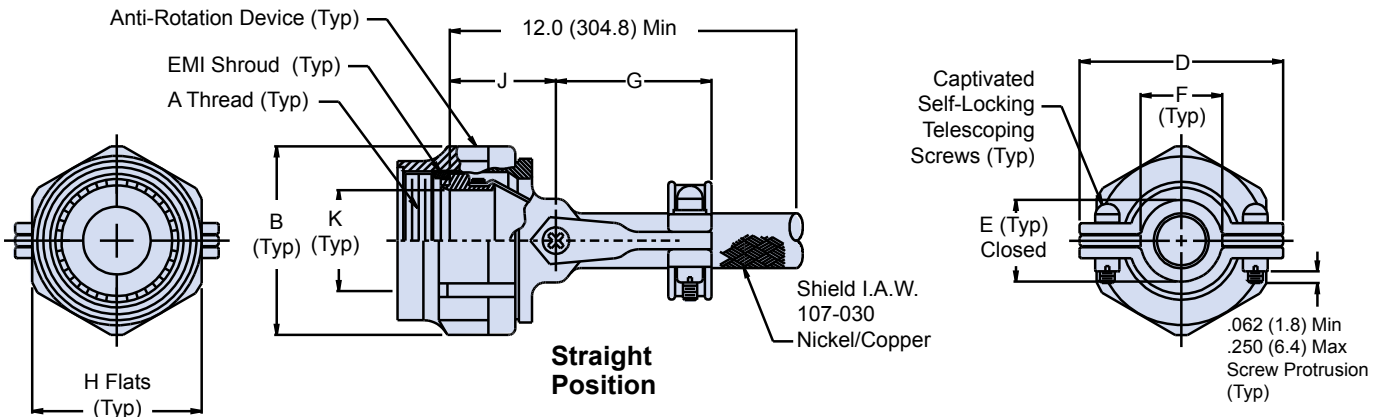

**H**

**319-064**  
**Composite Self-Locking Rotatable Coupling**  
**Composite Swing-Arm Strain Relief with**  
**Nickel/Copper EMI/RFI Shield Sock & Optional Split Ring**



**TABLE II: FINISHES**

Symbol	Finish
<b>XB</b>	Composite Material, No Plating, Color Black, Brass Interface Shroud and Adapter - Nickel Plated
<b>XMT</b>	Composite Material, No Plating, Color Black and Brown, Brass Interface Shroud and Adapter - Ni-PTFE 1000 Hour Grey™ (Nickel-Fluorocarbon Polymer)
<b>XN</b>	Composite Material, No Plating, Color Black and Brown, Brass Interface Shroud and Adapter - Selectively Cadmium Plated
<b>XO</b>	Composite Material, No Plating, Color Black and Brown, Brass Interface Shroud and Adapter - Nickel Plated

**TABLE III: CONNECTOR SHELL SIZE ORDER NUMBER**

Shell Size for Connector Designator		B Dia Max	D Max	E ±.06 (1.5)	F Min	G Max	H Flats		J ±.06 (1.5)	K Ref
F	H						Max	Min		
08	09	.812 (20.6)	.980 (24.9)	.265 (6.7)	.220 (5.9)	1.060 (26.9)	.750 (19.1)	.736 (18.7)	.940 (23.9)	.265 (6.7)
10	11	.938 (23.8)	1.050 (26.7)	.310 (7.9)	.270 (6.9)	1.090 (27.7)	.875 (22.2)	.860 (21.8)	.970 (24.6)	.370 (9.4)
12	13	1.125 (28.6)	1.200 (30.5)	.390 (9.9)	.350 (8.9)	1.180 (30.0)	1.000 (25.4)	.980 (24.9)	1.030 (26.2)	.506 (12.9)
14	15	1.250 (31.8)	1.300 (33.0)	.506 (12.9)	.470 (11.9)	1.240 (31.5)	1.125 (28.6)	1.100 (27.9)	1.090 (27.7)	.580 (14.7)
16	17	1.375 (34.9)	1.440 (36.6)	.591 (15.0)	.550 (14.0)	1.320 (33.5)	1.250 (31.8)	1.224 (31.1)	1.120 (28.4)	.705 (17.9)
18	19	1.500 (38.1)	1.560 (39.6)	.661 (16.8)	.620 (15.7)	1.390 (35.3)	1.375 (34.9)	1.469 (37.3)	1.150 (29.2)	.784 (19.9)
20	21	1.625 (41.3)	1.690 (42.9)	.744 (18.9)	.700 (17.8)	1.550 (39.4)	1.500 (38.1)	1.500 (38.1)	1.180 (30.0)	.909 (23.1)
22	23	1.750 (44.5)	1.770 (45.0)	.826 (21.0)	.780 (19.8)	1.550 (39.4)	1.625 (41.3)	1.581 (40.2)	1.250 (31.8)	1.034 (26.3)
24	25	1.875 (47.6)	1.890 (48.0)	.896 (22.8)	.850 (21.6)	1.610 (40.9)	1.750 (44.5)	1.960 (49.8)	1.280 (32.5)	1.149 (29.2)

Consult factory for additional entry sizes available.

**APPLICATION NOTES**

- Glenair series 600 Backshell assembly Tools are recommended for assembly and installation.
- Swing Arm locks in 45° increments—Sizes 08 thru 24, additional positioning increments are manufacturer's option.
- Captive Screw can remain engaged to the body when positioning the Arm. When tightened, the Screw shall not protrude into the inside surfaces.
- Fits Connector Designators: MIL-DTL-38999 Series I, II (F), MIL-DTL-38999 Series III and IV (H), MIL-DTL-5015 (A), and MIL-DTL-26482 (A).
- Metric dimensions (mm) are indicated in parentheses.
- For Mil-DTL-38999 Series II, add Mod Code -475. Backshell supplied less shroud.