

370-003
Water-Tight Cable Sealing Backshell
with Strain Relief
Low Profile - Rotatable Coupling

CONNECTOR
DESIGNATORS
A-F-H-L-S
ROTATABLE
COUPLING

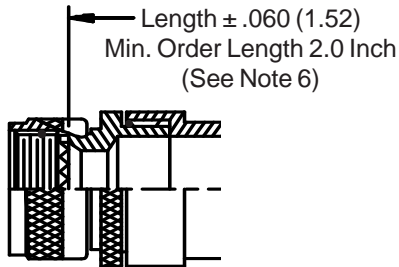

STYLE 2
(STRAIGHT
See Note 1)

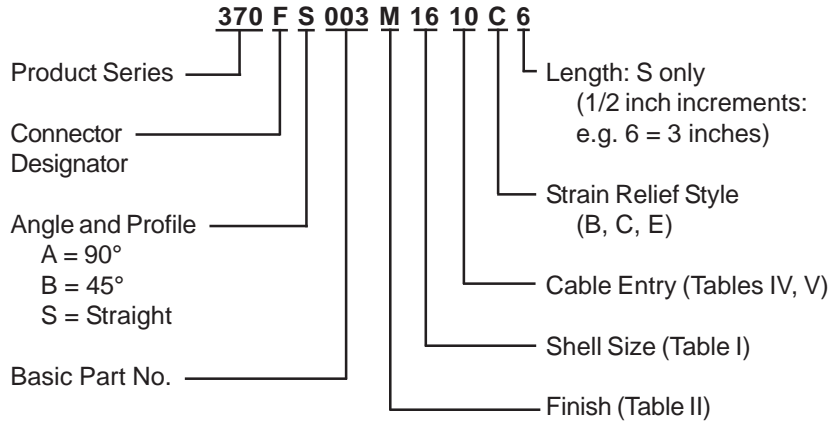
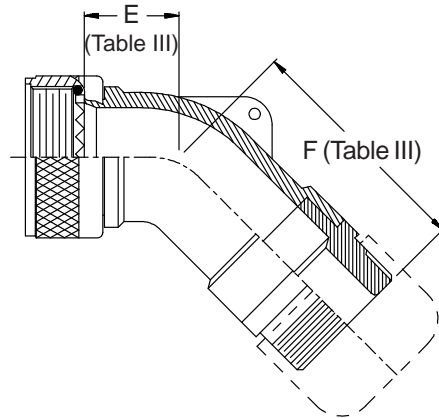
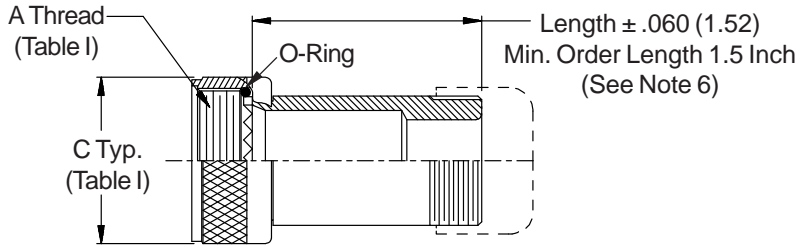

STYLE 2
(45° & 90°
See Note 1)

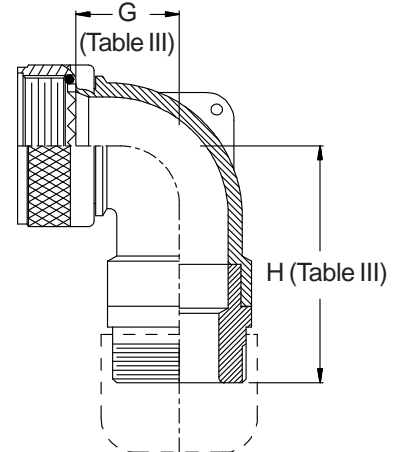

STYLE E
Medium Duty
(Table V)

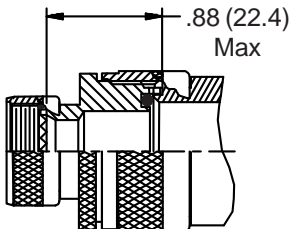

STYLE B
(Table IV)

STYLE C
Medium Duty
(Table IV)

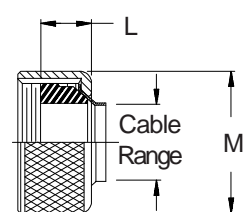
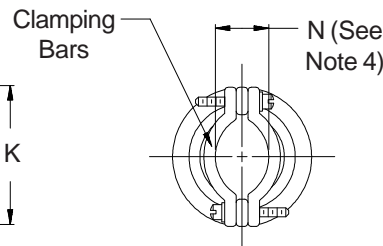
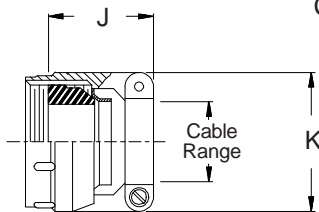
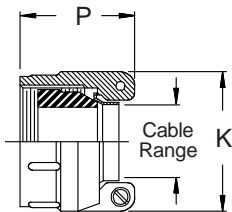

370-003
Water-Tight Cable Sealing Backshell
 with Strain Relief
 Low Profile - Rotatable Coupling



See inside back cover fold-out or pages 13 and 14 for unabridged Tables I and II.

Dash No.	J		K		N		Cable Range		P			
	Max		Max		Ref		Min	Max	Max			
03	1.219	(31.0)	.812	(20.6)	.135	(3.4)	.156	(4.0)	.219	(5.6)	1.031	(26.2)
04	1.219	(31.0)	.937	(23.8)	.203	(5.2)	.188	(4.8)	.312	(7.9)	1.031	(26.2)
06	1.219	(31.0)	1.062	(27.0)	.285	(7.2)	.281	(7.1)	.438	(11.1)	1.031	(26.2)
08	1.219	(31.0)	1.188	(30.2)	.350	(8.9)	.312	(7.9)	.531	(13.5)	1.031	(26.2)
10	1.281	(32.5)	1.312	(33.3)	.390	(9.9)	.375	(9.5)	.625	(15.9)	1.094	(27.8)
12	1.281	(32.5)	1.562	(39.7)	.460	(11.7)	.500	(12.7)	.750	(19.1)	1.219	(31.0)
16	1.406	(35.7)	1.750	(44.5)	.510	(13.0)	.625	(15.9)	.938	(23.8)	1.219	(31.0)
20	1.656	(42.1)	2.250	(57.2)	.695	(17.7)	.938	(23.8)	1.250	(31.8)	1.344	(34.1)
24	1.906	(48.4)	2.375	(60.3)	.715	(18.2)	1.000	(25.4)	1.375	(34.9)	1.547	(39.3)
28	1.906	(48.4)	2.625	(66.7)	.915	(23.2)	1.250	(31.8)	1.625	(41.3)	1.547	(39.3)
32	2.000	(50.8)	2.812	(71.4)	1.070	(27.2)	1.500	(38.1)	1.875	(47.6)	1.734	(44.0)

Shell Size		E		F		G		H	
Conn. Desig.	H	Max		Max		Max		Max	
A-F-L-S									
08	09	.457	(11.6)	1.810	(46.0)	.500	(12.7)	1.820	(46.2)
10	11	.520	(13.2)	1.869	(47.5)	.595	(15.1)	1.940	(49.3)
12	13	.582	(14.8)	1.929	(49.0)	.610	(15.5)	1.960	(49.8)
14	15	.645	(16.4)	2.359	(59.9)	.700	(17.8)	2.369	(60.2)
16	17	.738	(18.7)	2.469	(62.7)	.885	(22.5)	2.459	(62.5)
18	19	.926	(23.5)	2.659	(67.5)	.975	(24.8)	2.629	(66.8)
20	21	.926	(23.5)	2.659	(67.5)	.975	(24.8)	2.629	(66.8)
22	23	1.020	(25.9)	2.872	(72.9)	1.125	(28.6)	2.802	(71.2)
24	25	1.020	(25.9)	2.872	(72.9)	1.125	(28.6)	2.802	(71.2)
28		1.145	(29.1)	2.905	(73.8)	1.225	(31.1)	2.955	(75.1)
32		1.207	(30.7)	3.005	(76.3)	1.575	(40.0)	3.205	(81.4)
36		1.238	(31.4)	3.315	(84.2)	1.775	(45.1)	3.255	(82.7)

GLENAIR SYMBOL	FINISH
B	Cadmium Plate, Olive Drab
C	Anodize, Black
G	Hard Coat, Anodic
M	Electroless Nickel
NF	Cadmium Plate, Olive Drab Over Electroless Nickel
See Inside Back Cover for Additional Finish Options	

1. When maximum cable entry (page 21) is exceeded, Style 2 will be supplied. Dimensions E, F, G and H will not apply. Please consult factory.
2. Metric dimensions (mm) are indicated in parentheses.
3. Cable range is defined as the accommodations range for the wire bundle or cable. Dimensions shown are not intended for inspection criteria.
4. Saddles are bottomed on Clamp Ears.
5. Interface O-Ring not supplied with Connector Designator A.
6. Consult factory for shorter lengths on straight backshells.

Dash No.	L		M		Cable Range			
	Max		Max		Min	Max		
03	.739	(18.8)	.812	(20.6)	.156	(4.0)	.219	(5.6)
04	.739	(18.8)	.937	(23.8)	.188	(4.8)	.312	(7.9)
06	.739	(18.8)	1.062	(27.0)	.281	(7.1)	.438	(11.1)
08	.739	(18.8)	1.188	(30.2)	.312	(7.9)	.531	(13.5)
10	.791	(20.1)	1.312	(33.3)	.375	(9.5)	.625	(15.9)
12	.880	(22.4)	1.562	(39.7)	.500	(12.7)	.750	(19.1)
16	.901	(22.9)	1.750	(44.5)	.625	(15.9)	.938	(23.8)
20	1.031	(26.2)	2.250	(57.2)	.938	(23.8)	1.250	(31.8)
24	1.250	(31.8)	2.375	(60.3)	1.000	(25.4)	1.375	(34.9)
28	1.250	(31.8)	2.625	(66.7)	1.250	(31.8)	1.625	(41.3)
32	1.312	(33.3)	2.812	(71.4)	1.500	(38.1)	1.875	(47.6)