

**CONNECTOR
 DESIGNATORS
 A-F-H-L-S**
**ROTATABLE
 COUPLING**

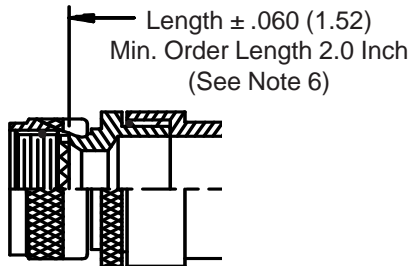

**STYLE 2
 (STRAIGHT
 See Note 1)**

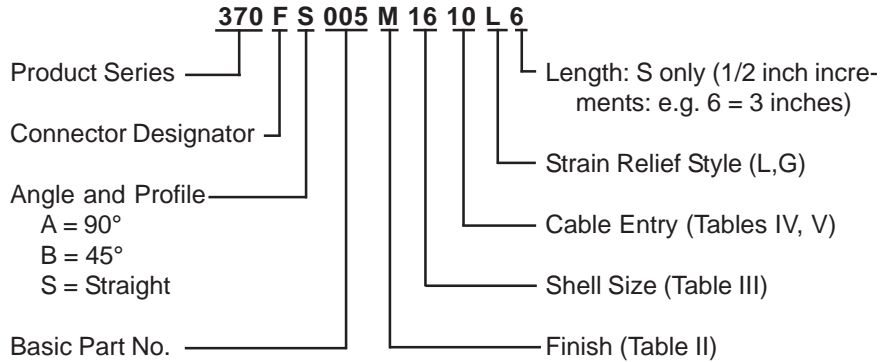
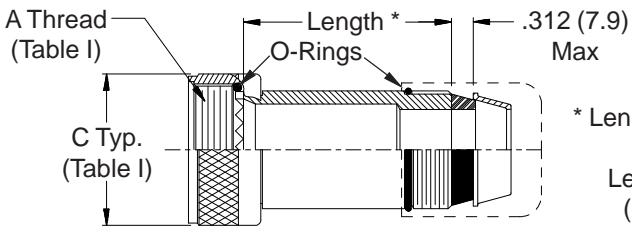

* Length ± .060 (1.52)
 Min. Order Length 1.5 Inch
 (See Note 6)

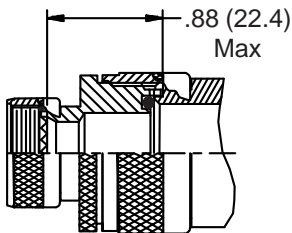

**STYLE 2
 (45° & 90°
 See Note 1)**

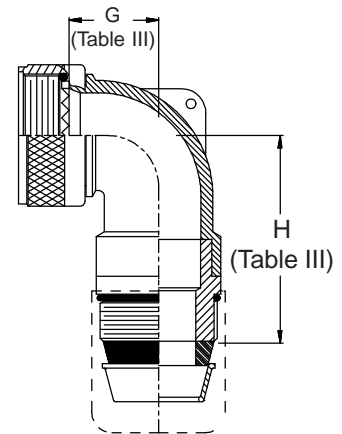
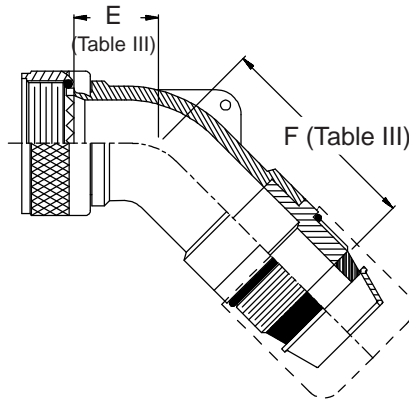

**STYLE L
 Light Duty (Table IV)**

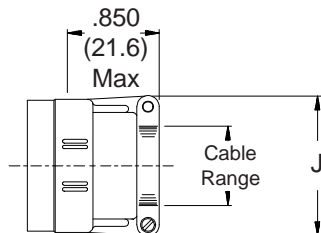

**STYLE G
 Light Duty (Table V)**

