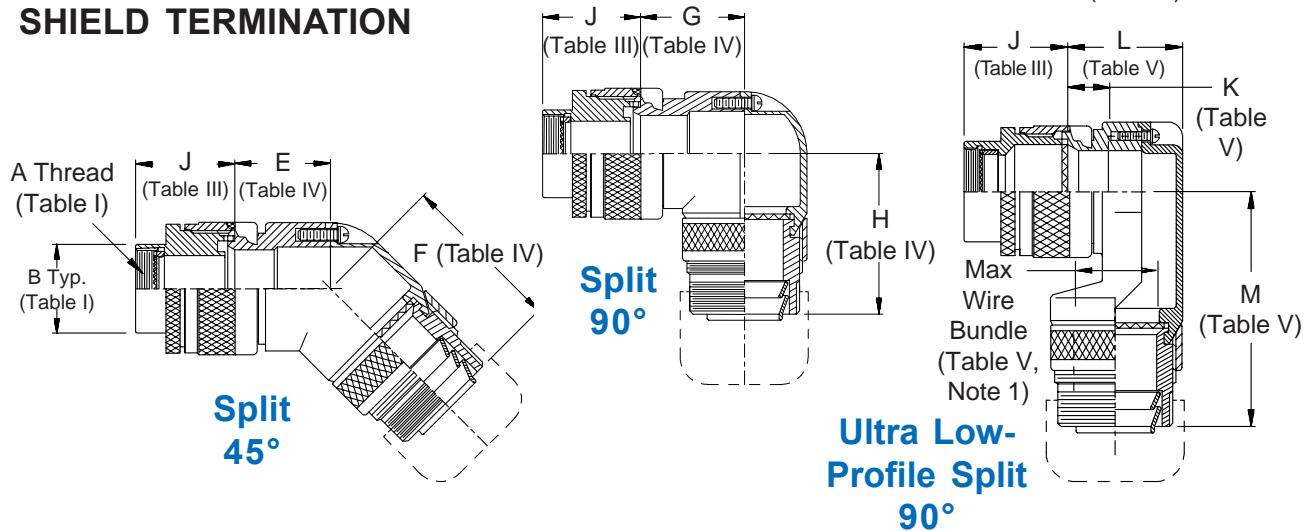
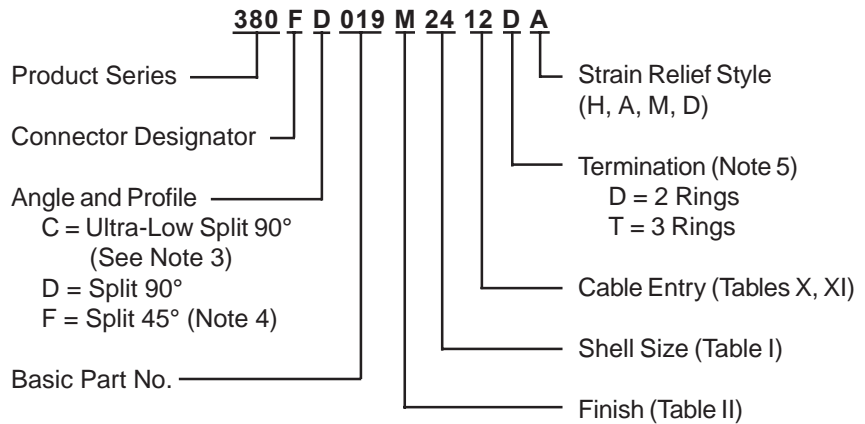
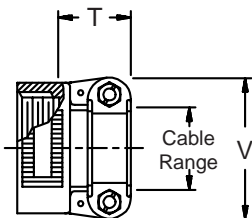
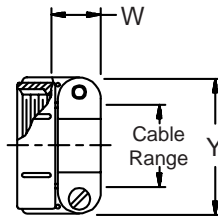
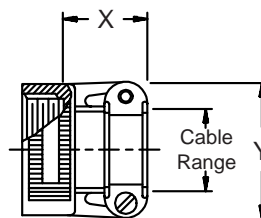
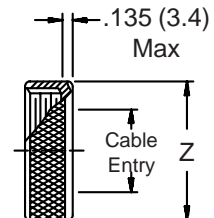

**CONNECTOR
DESIGNATORS**
A-B*-C-D-E-F
G-H-J-K-L-S

* Conn. Desig. B See Note 6

DIRECT COUPLING
**TYPE E INDIVIDUAL
AND/OR OVERALL**
SHIELD TERMINATION

STYLE H
 Heavy Duty
 (Table X)

STYLE A
 Medium Duty
 (Table XI)

STYLE M
 Medium Duty
 (Table XI)

STYLE D
 Medium Duty
 (Table XI)

1. Metric dimensions (mm) are indicated in parentheses.
2. Cable range is defined as the accommodations range for the wire bundle or cable. Dimensions shown are not intended for inspection criteria.
3. Function C Low Profile Elbow is available in Dash Numbers 03 thru 12 only.
4. Consult factory for available sizes of 45° (Symbol F).
5. Designate Symbol T for 3 ring termination of individual and overall braid. Designate D for standard 2 ring termination of individual or overall braid.
6. When using Connector Designator B refer to pages 18 and 19 for part number development.

380-019
EMI/RFI Non-Environmental Backshell
with Strain Relief
Type E - Direct Coupling - Split Shell



TABLE III: FRONT ADAPTER

Shell Size	J Max - Conn. Designator		
	A-E-F		
	J-H-L-S	D-B-G-K	C
08/09	1.180 (30.0)	1.440 (36.6)	
10/11	1.180 (30.0)	1.440 (36.6)	
12/13	1.180 (30.0)	1.440 (36.6)	1.735 (44.1)
14/15	1.180 (30.0)	1.440 (36.6)	1.915 (48.6)
16/17	1.380 (35.0)	1.560 (39.6)	1.915 (48.6)
18/19	1.380 (35.0)	1.560 (39.6)	1.915 (48.6)
20/21	1.380 (35.0)	1.560 (39.6)	1.915 (48.6)
22/23	1.380 (35.0)	1.560 (39.6)	1.915 (48.6)
24/25	1.380 (35.0)	1.560 (39.6)	1.915 (48.6)
28/29	1.610 (40.9)	1.560 (39.6)	1.915 (48.6)
32/33	1.610 (40.9)	1.750 (44.5)	1.915 (48.6)
36	1.610 (40.9)	1.750 (44.5)	1.915 (48.6)
40	1.610 (40.9)	2.190 (55.6)	1.915 (48.6)

TABLE IV: ELBOW DIMENSIONS

Elbow Size	E Max	F Max	G Max	H Max
03	.500 (12.7)	1.590 (40.4)	.680 (17.3)	1.530 (38.9)
04	.500 (12.7)	1.590 (40.4)	.680 (17.3)	1.530 (38.9)
06	.500 (12.7)	1.650 (41.9)	.750 (19.1)	1.590 (40.4)
08	.560 (14.2)	1.720 (43.7)	.810 (20.6)	1.660 (42.2)
10	.620 (15.7)	1.750 (44.5)	.870 (22.1)	1.690 (42.9)
12	.680 (17.3)	1.850 (47.0)	.930 (23.6)	1.790 (45.5)
16	.750 (19.1)	1.910 (48.5)	1.000 (25.4)	1.850 (47.0)
20	.820 (20.8)	1.970 (50.0)	1.060 (26.9)	1.910 (48.5)
24	.880 (22.4)	2.030 (51.6)	1.120 (28.4)	1.970 (50.0)
28	.940 (23.9)	2.090 (53.1)	1.180 (30.0)	2.030 (51.6)

TABLE V: ELBOW DIMENSIONS

Elbow Size	K Max		L Max	
03	.340 (8.6)	.681 (17.3)		
04	.270 (6.9)	.731 (18.6)		
06	.270 (6.9)	.731 (18.6)		
08	.280 (7.1)	.831 (21.1)		
10	.420 (10.7)	.981 (24.9)		
12	.540 (13.7)	1.181 (30.0)		

Elbow Size	M Max		Function C Max Wire Bundle	
03	1.730 (43.9)	.250 (6.4)		
04	1.730 (43.9)	.375 (9.5)		
06	1.890 (48.0)	.375 (9.5)		
08	1.890 (48.0)	.500 (12.7)		
10	1.960 (49.8)	.625 (15.9)		
12	1.960 (49.8)	.750 (19.1)		

TABLE X: CABLE ENTRY

Dash No.	T Max	V Max	Cable Range			
			Min		Max	
04	.780 (19.8)	.957 (24.3)	.125 (3.2)	.312 (7.9)		
06	.780 (19.8)	1.145 (29.1)	.250 (6.4)	.437 (11.1)		
08	.780 (19.8)	1.332 (33.8)	.312 (7.9)	.562 (14.3)		
10	.780 (19.8)	1.332 (33.8)	.350 (8.9)	.625 (15.9)		
12	.811 (20.6)	1.551 (39.4)	.500 (12.7)	.750 (19.1)		
16	.905 (23.0)	1.770 (45.0)	.625 (15.9)	.937 (23.8)		
20	1.092 (27.7)	2.113 (53.7)	.875 (22.2)	1.250 (31.8)		
24	1.124 (28.5)	2.363 (60.0)	1.000 (25.4)	1.375 (34.9)		
28	1.399 (35.5)	2.770 (70.4)	1.250 (31.8)	1.625 (41.3)		
32	1.399 (35.5)	3.020 (76.7)	1.437 (36.5)	1.875 (47.6)		

TABLE II: STANDARD FINISHES

GLENAIR SYMBOL	FINISH
B	Cadmium Plate, Olive Drab
M	Electroless Nickel
NF	Cadmium Plate, Olive Drab Over Electroless Nickel

See Inside Back Cover for Additional Finish Options

See inside back cover fold-out or pages 13 and 14 for unabridged Tables I and II.

TABLE XI: CABLE ENTRIES

Dash No.	W Max	X Max	Y Max	Z Max	Cable Range	
					Min **	Max
03*	.437 (11.1)	.760 (19.3)	.843 (21.4)	.630 (16.0)	.156 (4.0)	.250 (6.4)
04*	.437 (11.1)	.760 (19.3)	.906 (23.0)	.755 (19.2)	.188 (4.8)	.312 (7.9)
06*	.500 (12.7)	.760 (19.3)	1.093 (27.8)	.942 (23.9)	.281 (7.1)	.438 (11.1)
08	.563 (14.3)	.760 (19.3)	1.187 (30.1)	1.067 (27.1)	.344 (8.7)	.562 (14.3)
10	.563 (14.3)	.760 (19.3)	1.281 (32.5)	1.192 (30.3)	.375 (9.5)	.625 (15.9)
12	.563 (14.3)	.760 (19.3)	1.500 (38.1)	1.380 (35.1)	.438 (11.1)	.750 (19.1)
16	.656 (16.7)	1.073 (27.3)	1.719 (43.7)	1.535 (39.0)	.562 (14.3)	.938 (23.8)
20	.656 (16.7)	1.323 (33.6)	2.062 (52.4)	1.848 (46.9)	.750 (19.1)	1.250 (31.8)
24	.656 (16.7)	1.323 (33.6)	2.312 (58.7)	2.255 (57.3)	.781 (19.8)	1.375 (34.9)
28	1.188 (30.2)	1.572 (39.9)	2.719 (69.1)	2.505 (63.6)	.969 (24.6)	1.625 (41.3)
32*	1.187 (30.1)	1.572 (39.9)	2.969 (75.4)	2.755 (70.0)	1.125 (28.6)	1.875 (47.6)
40*	1.125 (28.6)	1.572 (39.9)	3.531 (89.7)	3.255 (82.7)	1.469 (37.3)	2.375 (60.3)

* Not available in Style M clamp. ** Not Applicable Style D