

**CONNECTOR
DESIGNATORS
A-F-H-L-S
ROTATABLE
COUPLING**

**TYPE D INDIVIDUAL
OR OVERALL
SHIELD TERMINATION**

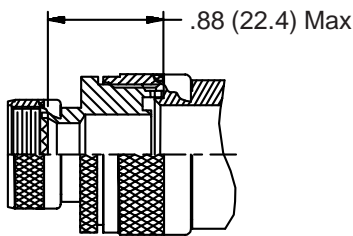
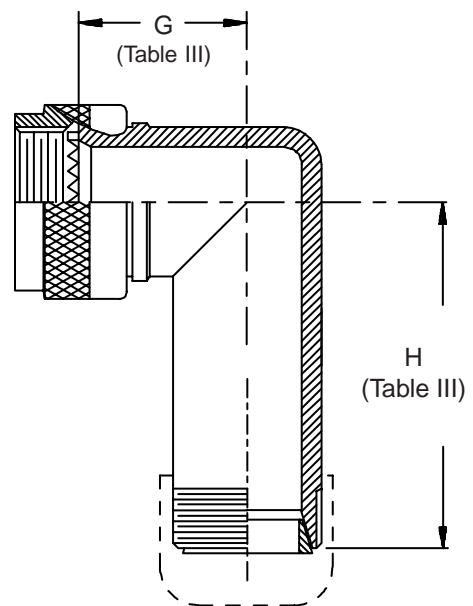
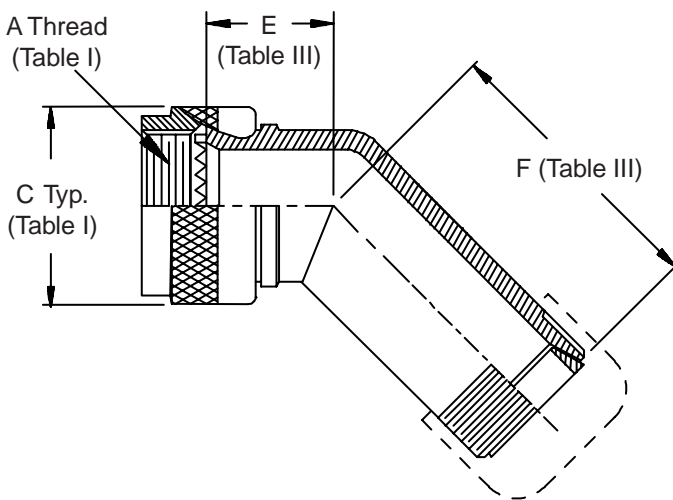
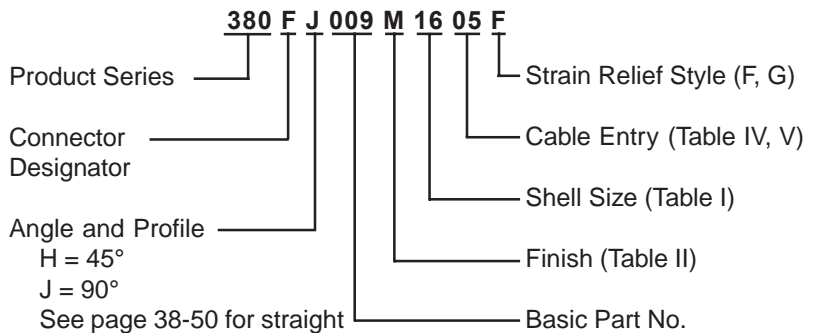

STYLE 2
(See Note 1)

STYLE F
Light Duty
(Table IV)

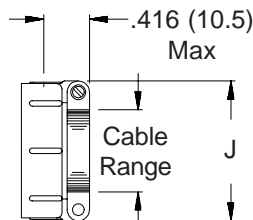

STYLE G
Light Duty
(Table V)

