

**CONNECTOR
 DESIGNATORS
 A-F-H-L-S
 SELF-LOCKING
 ROTATABLE
 COUPLING**

**TYPE F INDIVIDUAL
 AND/OR OVERALL
 SHIELD TERMINATION**

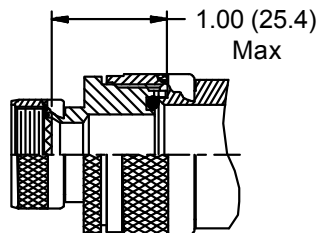
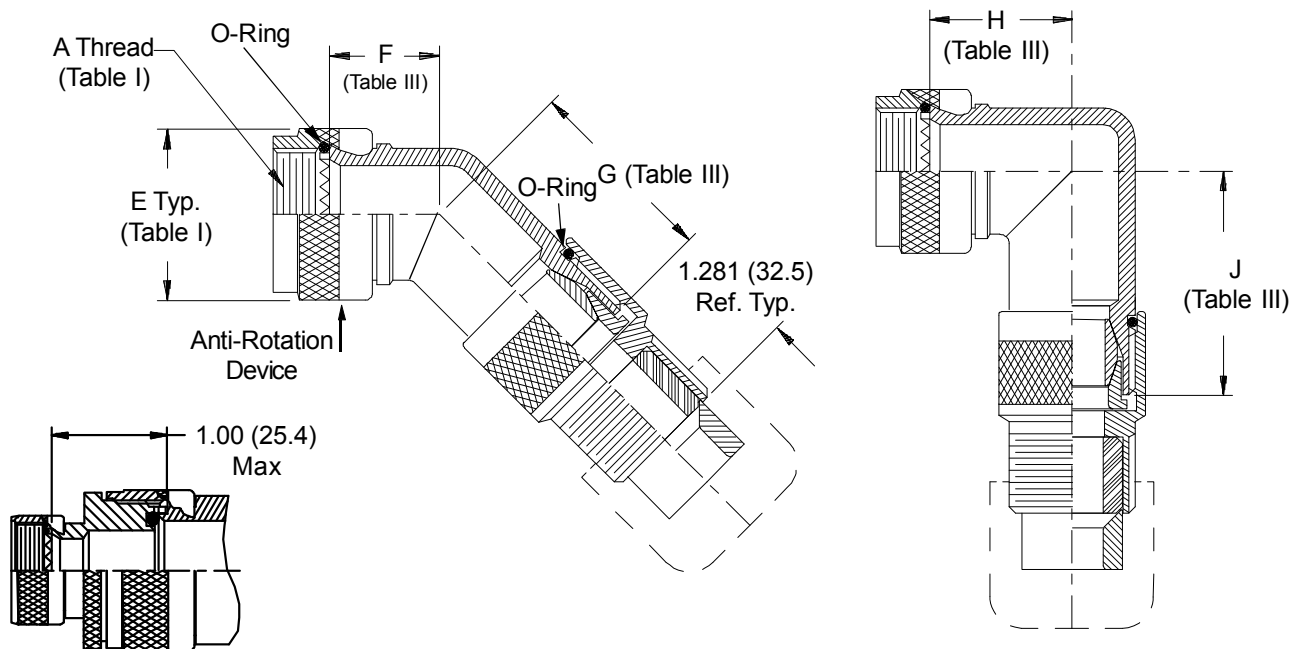
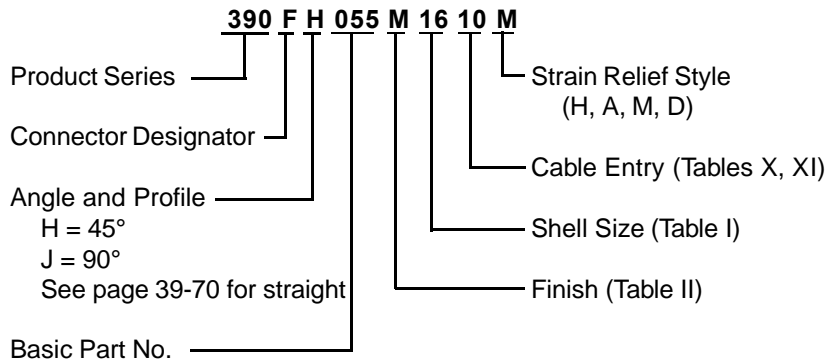

STYLE 2
(See Note 1)

STYLE H
Heavy Duty
(Table X)

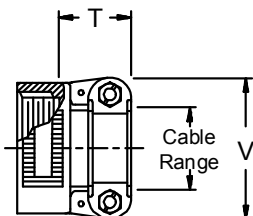

STYLE A
Medium Duty
(Table XI)

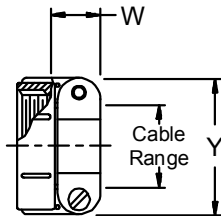

STYLE M
Medium Duty
(Table XI)

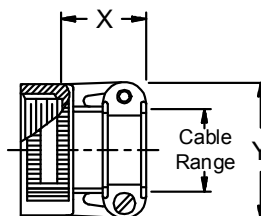

STYLE D
Medium Duty
(Table XI)

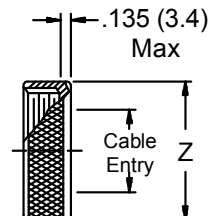

390-055
Submersible EMI/RFI Cable Sealing Backshell
 with Strain Relief
 Type F - Self-Locking Rotatable Coupling - Standard Profile



See inside back cover fold-out or pages 13 and 14 for Tables I and II.

Shell Size		F	G	H	J
Conn. Desig.	H	Max	Max	Max	Max
A-F-L-S					
08	09	.795 (20.2)	1.031 (26.2)	.906 (23.0)	1.157 (29.4)
10	11	.820 (20.8)	1.063 (27.0)	.966 (24.5)	1.217 (30.9)
12	13	.844 (21.4)	1.094 (27.8)	1.026 (26.1)	1.277 (32.4)
14	15	.861 (21.9)	1.119 (28.4)	1.076 (27.3)	1.347 (34.2)
16	17	.888 (22.6)	1.147 (29.1)	1.136 (28.9)	1.407 (35.7)
18	19	.904 (23.0)	1.157 (29.4)	1.176 (29.9)	1.427 (36.2)
20	21	.929 (23.6)	1.177 (29.9)	1.236 (31.4)	1.487 (37.8)
22	23	.956 (24.3)	1.217 (30.9)	1.296 (32.9)	1.567 (39.8)
24	25	.979 (24.9)	1.247 (31.7)	1.356 (34.4)	1.637 (41.6)

Dash No.	T Max	V Max	Cable Range	
			Min	Max
04	.780 (19.8)	.957 (24.3)	.125 (3.2)	.312 (7.9)
06	.780 (19.8)	1.145 (29.1)	.250 (6.4)	.437 (11.1)
08	.780 (19.8)	1.332 (33.8)	.387 (9.3)	.562 (14.3)
10	.780 (19.8)	1.332 (33.8)	.350 (8.9)	.625 (15.9)
12	.811 (20.6)	1.551 (39.4)	.500 (12.7)	.750 (19.1)
16	.905 (23.0)	1.770 (45.0)	.625 (15.9)	.937 (23.8)
20	1.092 (27.7)	2.113 (53.7)	.875 (22.2)	1.250 (31.8)
24	1.124 (28.5)	2.363 (60.0)	1.000 (25.4)	1.375 (34.9)
28	1.399 (35.5)	2.770 (70.4)	1.250 (31.8)	1.625 (41.3)
32	1.399 (35.5)	3.020 (76.7)	1.437 (36.5)	1.875 (47.6)

1. When maximum cable entry (page 21) is exceeded, Style 2 will be supplied. Dimensions F, G, H and J will not apply. Please consult factory.
2. Metric dimensions (mm) are indicated in parentheses.
3. Cable range is defined as the accommodations range for the wire bundle or cable. Dimensions shown are not intended for inspection criteria.
4. Interface O-Ring not supplied with connector designator A.

Dash No.	W Max	X Max	Y Max	Z Max	Cable Range	
					Min	Max
03*	.437 (11.1)	.760 (19.3)	.843 (21.4)	.630 (16.0)	.156 (4.0)	.250 (6.4)
04*	.437 (11.1)	.760 (19.3)	.906 (23.0)	.755 (19.2)	.188 (4.8)	.312 (7.9)
06*	.500 (12.7)	.760 (19.3)	1.093 (27.8)	.942 (23.9)	.281 (7.1)	.438 (11.1)
08	.563 (14.3)	.760 (19.3)	1.187 (30.1)	1.067 (27.1)	.387 (9.3)	.562 (14.3)
10	.563 (14.3)	.760 (19.3)	1.281 (32.5)	1.192 (30.3)	.375 (9.5)	.625 (15.9)
12	.563 (14.3)	.760 (19.3)	1.500 (38.1)	1.380 (35.1)	.438 (11.1)	.750 (19.1)
16	.656 (16.7)	1.073 (27.3)	1.719 (43.7)	1.535 (39.0)	.625 (15.9)	.938 (23.8)
20	.656 (16.7)	1.323 (33.6)	2.062 (52.4)	1.848 (46.9)	.875 (22.2)	1.250 (31.8)
24	.656 (16.7)	1.323 (33.6)	2.312 (58.7)	2.255 (57.3)	1.000 (25.4)	1.375 (34.9)
28	1.188 (30.2)	1.572 (39.9)	2.719 (69.1)	2.505 (63.6)	1.250 (31.8)	1.625 (41.3)
32*	1.187 (30.1)	1.572 (39.9)	2.969 (75.4)	2.755 (70.0)	1.437 (36.5)	1.875 (47.6)
40*	1.125 (28.6)	1.572 (39.9)	3.531 (89.7)	3.255 (82.7)	1.875 (47.6)	2.375 (60.3)

* Not available in Style M clamp.