

**CONNECTOR
 DESIGNATORS
 A-F-H-L-S
 ROTATABLE
 COUPLING**

**TYPE C OVERALL
 SHIELD TERMINATION**

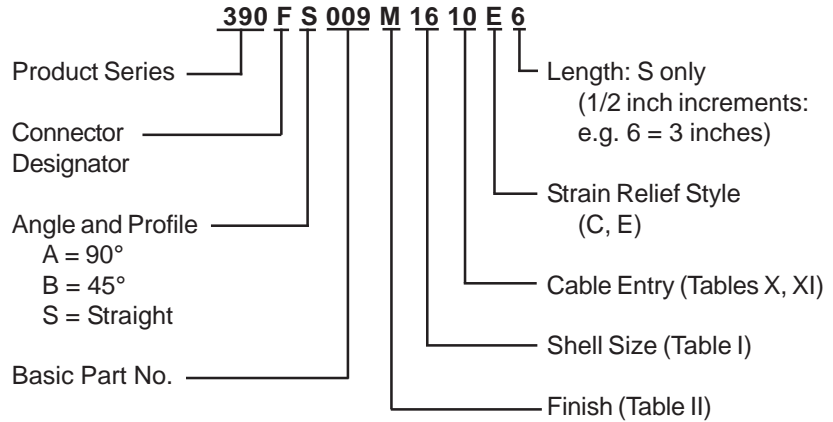

Length ± .060 (1.52)
 Minimum Order Length 2.0 Inch
 (See Note 4)

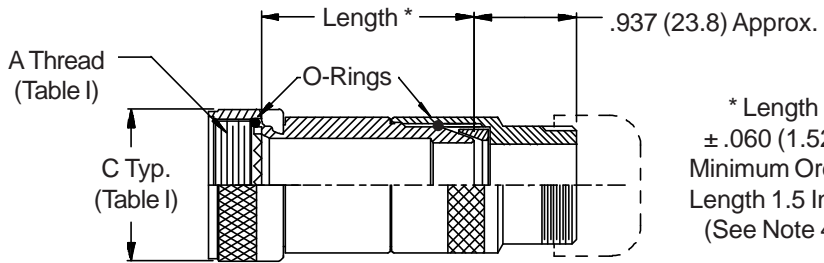

* Length
 ± .060 (1.52)
 Minimum Order
 Length 1.5 Inch
 (See Note 4)

**STYLE 2
 (STRAIGHT)**

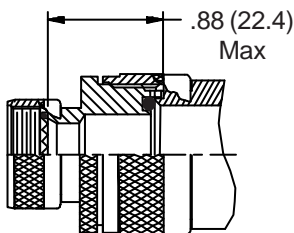

**STYLE 2
 (45° & 90°)**

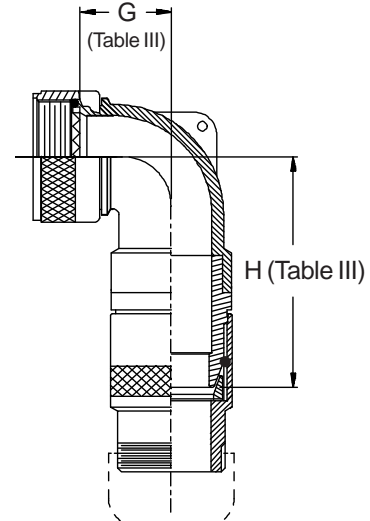
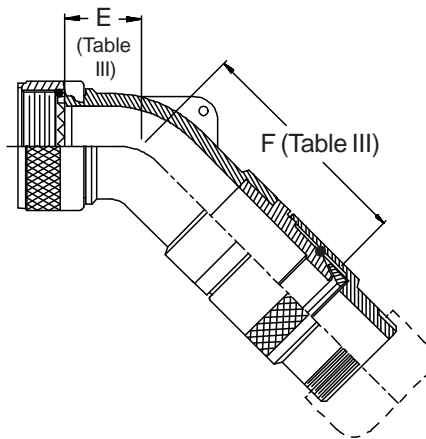

**STYLE C
 Medium Duty
 (Table X)**

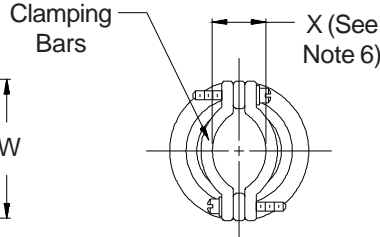
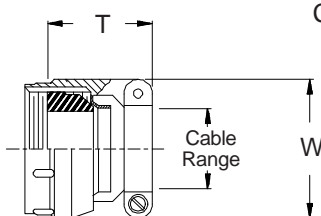

**STYLE E
 Medium Duty
 (Table XI)**

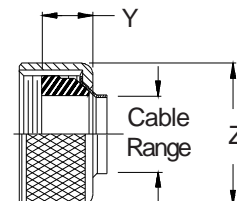

390-009
Submersible EMI/RFI Cable Sealing Backshell
 with Strain Relief
 Type C - Rotatable Coupling - Low Profile



See inside back cover fold-out or pages 13 and 14 for Tables I and II.

TABLE III: ELBOW DIMENSIONS

| Shell Size | | E Max | F Max | G Max | H Max |
|-------------------------|----|--------------|---------------|--------------|---------------|
| Conn. Desig. A-F-L-S | H | | | | |
| 08 | 09 | | | .500 (12.7) | 2.725 (69.2) |
| 10 | 11 | .520 (13.2) | 2.775 (70.5) | .595 (15.1) | 2.845 (72.3) |
| 12 | 13 | .582 (14.8) | 2.835 (72.0) | .610 (15.5) | 2.865 (72.8) |
| 14 | 15 | .645 (16.4) | 3.554 (90.3) | .700 (17.8) | 3.564 (90.5) |
| 16 | 17 | .738 (18.7) | 3.664 (93.1) | .885 (22.5) | 3.654 (92.8) |
| 18 | 19 | .926 (23.5) | 3.854 (97.9) | .975 (24.8) | 3.824 (97.1) |
| 20 | 21 | .926 (23.5) | 3.854 (97.9) | .975 (24.8) | 3.824 (97.1) |
| 22 | 23 | 1.020 (25.9) | 4.192 (106.5) | 1.125 (28.6) | 4.122 (104.7) |
| 24 | 25 | 1.020 (25.9) | 4.192 (106.5) | 1.125 (28.6) | 4.122 (104.7) |
| 28 | | 1.145 (29.1) | 4.225 (107.3) | 1.225 (31.1) | 4.275 (108.6) |
| 32 | | 1.207 (30.7) | 4.325 (109.9) | 1.575 (40.0) | 4.525 (114.9) |
| 36 | | 1.238 (31.4) | 4.465 (113.4) | 1.775 (45.1) | 4.575 (116.2) |

TABLE X: CABLE ENTRY

| Dash No. | T Max | W Max | X Ref | Cable Range | |
|----------|--------------|--------------|--------------|--------------|--------------|
| | | | | Min | Max |
| 03 | 1.219 (31.0) | .812 (20.6) | .135 (3.4) | .156 (4.0) | .219 (5.6) |
| 04 | 1.219 (31.0) | .937 (23.8) | .203 (5.2) | .188 (4.8) | .312 (7.9) |
| 06 | 1.219 (31.0) | 1.062 (27.0) | .285 (7.2) | .281 (7.1) | .438 (11.1) |
| 08 | 1.219 (31.0) | 1.188 (30.2) | .350 (8.9) | .312 (7.9) | .531 (13.5) |
| 10 | 1.281 (32.5) | 1.312 (33.3) | .390 (9.9) | .375 (9.5) | .625 (15.9) |
| 12 | 1.281 (32.5) | 1.562 (39.7) | .460 (11.7) | .500 (12.7) | .750 (19.1) |
| 16 | 1.406 (35.7) | 1.750 (44.5) | .510 (13.0) | .625 (15.9) | .938 (23.8) |
| 20 | 1.656 (42.1) | 2.250 (57.2) | .695 (17.7) | .938 (23.8) | 1.250 (31.8) |
| 24 | 1.906 (48.4) | 2.375 (60.3) | .715 (18.2) | 1.000 (25.4) | 1.375 (34.9) |
| 28 | 1.906 (48.4) | 2.625 (66.7) | .915 (23.2) | 1.250 (31.8) | 1.625 (41.3) |
| 32 | 2.000 (50.8) | 2.812 (71.4) | 1.070 (27.2) | 1.500 (38.1) | 1.875 (47.6) |

TABLE XI: CABLE ENTRY

| Dash No. | Y Max | Z Max | Cable Range | |
|----------|--------------|--------------|--------------|--------------|
| | | | Min | Max |
| 03 | .739 (18.8) | .812 (20.6) | .156 (4.0) | .219 (5.6) |
| 04 | .739 (18.8) | .937 (23.8) | .188 (4.8) | .312 (7.9) |
| 06 | .739 (18.8) | 1.062 (27.0) | .281 (7.1) | .438 (11.1) |
| 08 | .739 (18.8) | 1.188 (30.2) | .312 (7.9) | .531 (13.5) |
| 10 | .791 (20.1) | 1.312 (33.3) | .375 (9.5) | .625 (15.9) |
| 12 | .880 (22.4) | 1.562 (39.7) | .500 (12.7) | .750 (19.1) |
| 16 | .901 (22.9) | 1.750 (44.5) | .625 (15.9) | .938 (23.8) |
| 20 | 1.031 (26.2) | 2.250 (57.2) | .938 (23.8) | 1.250 (31.8) |
| 24 | 1.250 (31.8) | 2.375 (60.3) | 1.000 (25.4) | 1.375 (34.9) |
| 28 | 1.250 (31.8) | 2.625 (66.7) | 1.250 (31.8) | 1.625 (41.3) |
| 32 | 1.312 (33.3) | 2.812 (71.4) | 1.500 (38.1) | 1.875 (47.6) |

1. When maximum cable entry (page 21) is exceeded, Style 2 will be supplied. Dimensions E, F, G and H will not apply. Please consult factory.
2. Metric dimensions (mm) are indicated in parentheses.
3. Cable range is defined as the accommodations range for the wire bundle or cable. Dimensions shown are not intended for inspection criteria.
4. Consult factory for shorter lengths on straight backshells.
5. Interface O-Ring not supplied with connector designator A.
6. Saddles are bottomed on Clamp Ears.