

CONNECTOR DESIGNATORS
A-B*-C-D-E-F
G-H-J-K-L-S
 * Conn. Desig. B See Note 5
DIRECT COUPLING

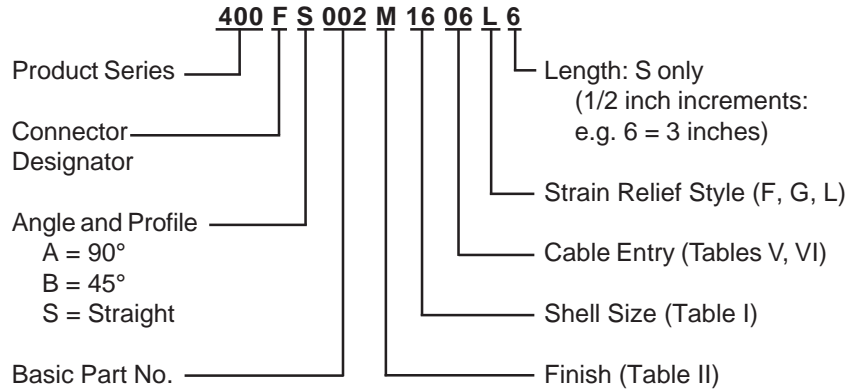

Length ± .060 (1.52)
 Min. Order Length 2.0 Inch
 (See Note 4)

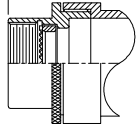

STYLE 2
(STRAIGHT)
 See Note 1)

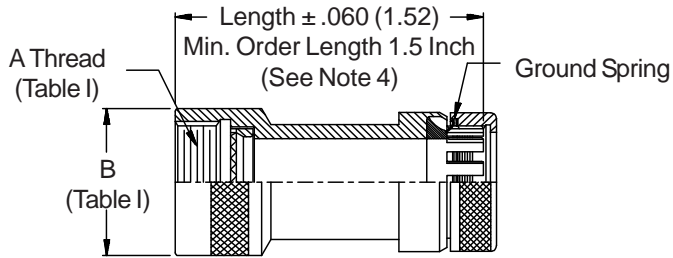

Shown with Style G Nut

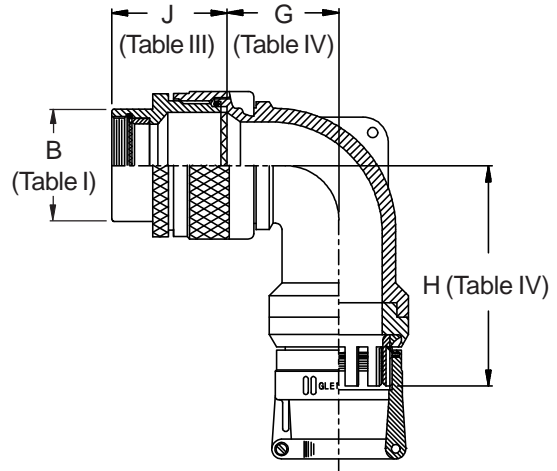
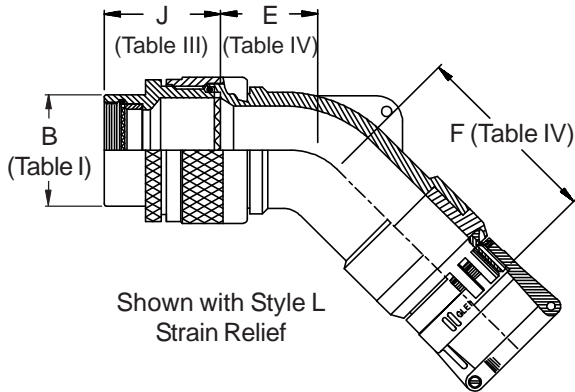

STYLE F
 Light Duty
 (Table VI)

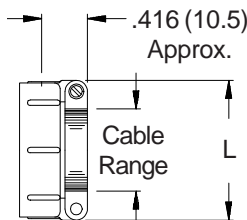

STYLE G
 Light Duty
 (Table V)

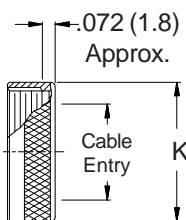

STYLE L
 Light Duty
 (Table VI)

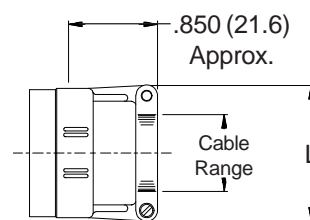

400-002
TAG® Ring Backshell
with Strain Relief
Direct Coupling - Low Profile



TABLE III: FRONT ADAPTER

Shell Size	J Max - Conn. Designator		
	A-D-E-F		
	J-H-L-S	B-G-K	C
08/09	1.000 (25.4)	1.250 (31.8)	
10/11	1.000 (25.4)	1.250 (31.8)	
12/13	1.000 (25.4)	1.250 (31.8)	1.735 (44.1)
14/15	1.000 (25.4)	1.250 (31.8)	1.915 (48.6)
16/17	1.000 (25.4)	1.416 (36.0)	1.915 (48.6)
18/19	1.000 (25.4)	1.416 (36.0)	1.915 (48.6)
20/21	1.000 (25.4)	1.416 (36.0)	1.915 (48.6)
22/23	1.000 (25.4)	1.416 (36.0)	1.915 (48.6)
24/25	1.000 (25.4)	1.416 (36.0)	1.915 (48.6)
28/29	1.000 (25.4)	1.416 (36.0)	1.915 (48.6)
32/33	1.000 (25.4)	1.416 (36.0)	1.915 (48.6)
36	1.000 (25.4)	1.416 (36.0)	1.915 (48.6)
40	1.000 (25.4)	1.687 (42.9)	1.915 (48.6)

**See inside back cover
fold-out or pages 13 and
14 for Tables I and II.**

1. When maximum cable entry (page 22) is exceeded, Style 2 will be supplied. (Function S only).
2. Metric dimensions (mm) are indicated in parentheses.
3. Cable range is defined as the accommodations range for the wire bundle or cable. Dimensions shown are not intended for inspection criteria.
4. Consult factory for shorter lengths on straight backshells.
5. When using Connector Designator B refer to pages 18 and 19 for part number development.

TABLE IV: ELBOW DIMENSIONS

Elbow Size	E Max	F Max	G Max	H Max
02	.630 (16.0)	1.720 (43.7)	.636 (16.2)	1.670 (42.4)
03	.630 (16.0)	1.720 (43.7)	.709 (18.0)	1.790 (45.5)
04	.692 (17.6)	1.780 (45.2)	.734 (18.6)	1.810 (46.0)
05	.755 (19.2)	1.870 (47.5)	.829 (21.1)	1.880 (47.8)
06	.848 (21.5)	1.970 (50.0)	.990 (25.1)	1.970 (50.0)
07	1.036 (26.3)	2.170 (55.1)	1.000 (25.4)	2.140 (54.4)
08	1.130 (28.7)	2.310 (58.7)	1.325 (33.7)	2.250 (57.2)
09	1.130 (28.7)	2.310 (58.7)	1.325 (33.7)	2.250 (57.2)
10	1.130 (28.7)	2.310 (58.7)	1.325 (33.7)	2.250 (57.2)

TABLE V: CABLE ENTRY

Dash No.	K Max	Cable Entry Max
02	.545 (13.8)	.250 (6.4)
03	.670 (17.0)	.375 (9.5)
04	.795 (20.2)	.500 (12.7)
05	.920 (23.4)	.625 (15.9)
06	1.045 (26.5)	.750 (19.1)
07	1.170 (29.7)	.875 (22.2)
08	1.295 (32.9)	1.000 (25.4)
09	1.420 (36.1)	1.125 (28.6)
10	1.670 (42.4)	1.250 (31.8)

TABLE VI: CABLE ENTRY

Dash No.	L Max	Cable Range	
		Min	Max
02	.968 (24.6)	.125 (3.2)	.250 (6.4)
03	1.046 (26.6)	.250 (6.4)	.375 (9.5)
04	1.156 (29.4)	.250 (6.4)	.500 (12.7)
05	1.218 (30.9)	.375 (9.5)	.625 (15.9)
06	1.343 (34.1)	.500 (12.7)	.750 (19.1)
07	1.468 (37.3)	.625 (15.9)	.875 (22.2)
08	1.593 (40.5)	.625 (15.9)	1.000 (25.4)
09	1.718 (43.6)	.750 (19.1)	1.125 (28.6)
10	1.843 (46.8)	.875 (22.2)	1.250 (31.8)