

CONNECTOR DESIGNATORS
A-F-H-L-S
SELF-LOCKING ROTATABLE COUPLING

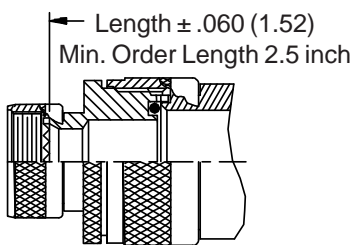

STYLE 2 (STRAIGHT)
 See Note 1)

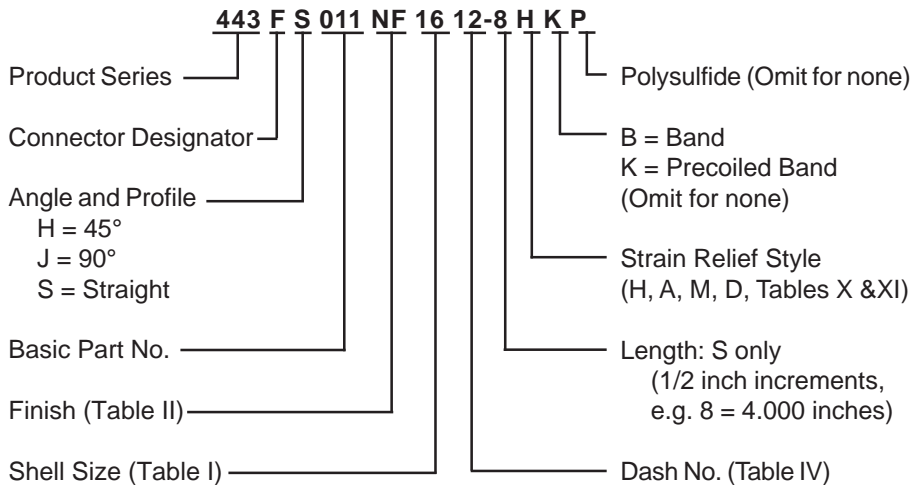
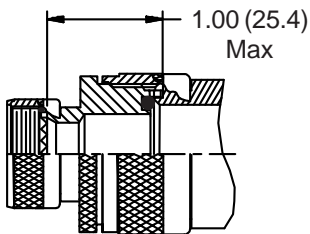
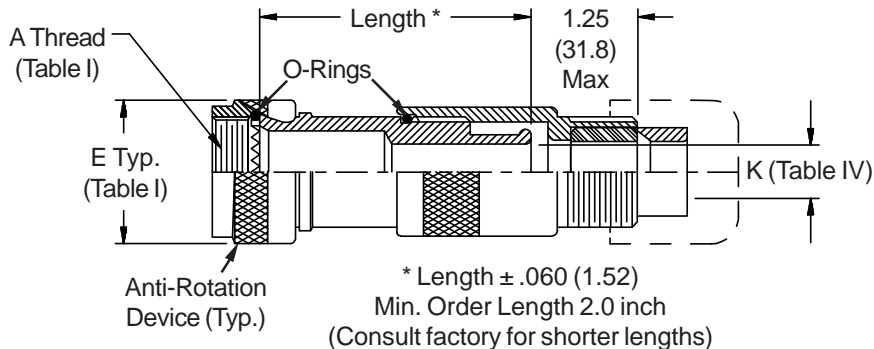

STYLE 2 (45° & 90°)
 See Note 1)

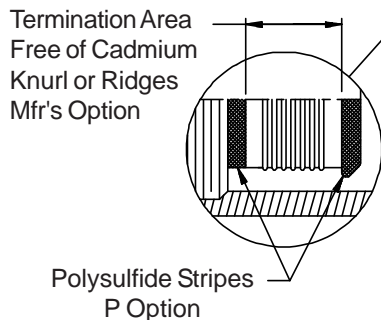
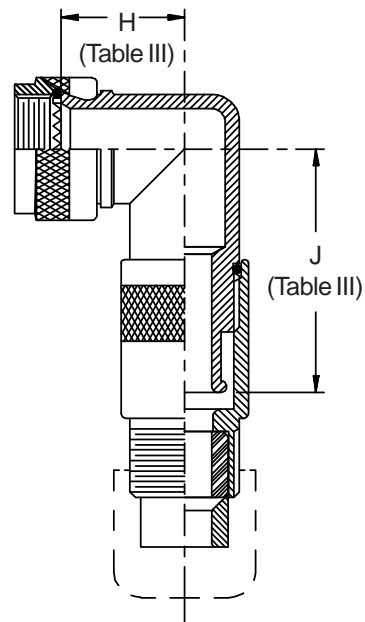
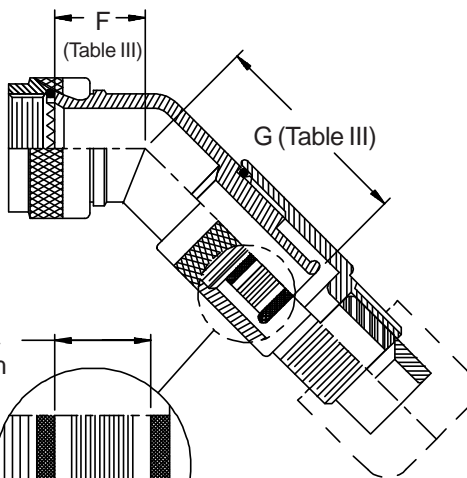

EMI/RFI Cable Sealing Backshell
Band-in-a-Can with Strain-Relief
Self-Locking Rotatable Coupling - Standard Profile



See inside back cover fold-out or pages 13 and 14 for Tables I and II.

TABLE III: ELBOW DIMENSIONS

Shell Size Conn. Desig. A-F-L-S H	F Max	G Max	H Max	J Max
08 09	.795 (20.2)	1.380 (35.1)	.906 (23.0)	1.500 (38.1)
10 11	.820 (20.8)	1.410 (35.8)	.966 (24.5)	1.550 (39.4)
12 13	.844 (21.4)	1.430 (36.3)	1.026 (26.1)	1.610 (40.9)
14 15	.861 (21.9)	1.460 (37.1)	1.076 (27.3)	1.680 (42.7)
16 17	.888 (22.6)	1.480 (37.6)	1.136 (28.9)	1.740 (44.2)
18 19	.904 (23.0)	1.490 (37.8)	1.176 (29.9)	1.760 (44.7)
20 21	.929 (23.6)	1.510 (38.4)	1.236 (31.4)	1.820 (46.2)
22 23	.956 (24.3)	1.550 (39.4)	1.296 (32.9)	1.900 (48.3)
24 25	.979 (24.9)	1.580 (40.1)	1.356 (34.4)	1.970 (50.0)

TABLE IV: CABLE ENTRY

Dash No.	Clamp Size	K Dia
02	03	.125 (3.2)
03	03	.188 (4.8)
04	03	.250 (6.4)
05	04	.312 (7.9)
06	06	.375 (9.5)
07	06	.438 (11.1)
08	08	.500 (12.7)
09	10	.562 (14.3)
10	10	.625 (15.9)
11	12	.688 (17.5)
12	12	.750 (19.1)
13	16	.812 (20.6)
14	16	.875 (22.2)
15	16	.938 (23.8)
16	20	1.000 (25.4)
17	20	1.062 (27.0)
18	20	1.125 (28.6)
20	20	1.250 (31.8)
22	24	1.375 (34.9)
24	28	1.500 (38.1)

TABLE X: CABLE ENTRY

Clamp Size	T Max	V Max	Cable Range	
			Min	Max
04	.780 (19.8)	.957 (24.3)	.125 (3.2)	.312 (7.9)
06	.780 (19.8)	1.145 (29.1)	.250 (6.4)	.437 (11.1)
08	.780 (19.8)	1.332 (33.8)	.387 (9.8)	.562 (14.3)
10	.780 (19.8)	1.332 (33.8)	.350 (8.9)	.625 (15.9)
12	.811 (20.6)	1.551 (39.4)	.500 (12.7)	.750 (19.1)
16	.905 (23.0)	1.770 (45.0)	.625 (15.9)	.937 (23.8)
20	1.092 (27.7)	2.113 (53.7)	.875 (22.2)	1.250 (31.8)
24	1.124 (28.5)	2.363 (60.0)	1.000 (25.4)	1.375 (34.9)
28	1.399 (35.5)	2.770 (70.4)	1.250 (31.8)	1.625 (41.3)

TABLE XI: CABLE ENTRY

Clamp Size	W Max	X Max	Y Max	Z Max	Cable Range	
					Min **	Max
03*	.437 (11.1)	.760 (19.3)	.843 (21.4)	.630 (16.0)	.156 (4.0)	.250 (6.4)
04*	.437 (11.1)	.760 (19.3)	.906 (23.0)	.755 (19.2)	.188 (4.8)	.312 (7.9)
06*	.500 (12.7)	.760 (19.3)	1.093 (27.8)	.942 (23.9)	.281 (7.1)	.438 (11.1)
08	.563 (14.3)	.760 (19.3)	1.187 (30.1)	1.067 (27.1)	.387 (9.8)	.562 (14.3)
10	.563 (14.3)	.760 (19.3)	1.281 (32.5)	1.192 (30.3)	.375 (9.5)	.625 (15.9)
12	.563 (14.3)	.760 (19.3)	1.500 (38.1)	1.380 (35.1)	.438 (11.1)	.750 (19.1)
16	.656 (16.7)	1.073 (27.3)	1.719 (43.7)	1.535 (39.0)	.625 (15.9)	.938 (23.8)
20	.656 (16.7)	1.323 (33.6)	2.062 (52.4)	1.848 (46.9)	.875 (22.2)	1.250 (31.8)
24	.656 (16.7)	1.323 (33.6)	2.312 (58.7)	2.255 (57.3)	1.000 (25.4)	1.375 (34.9)
28	1.188 (30.2)	1.572 (39.9)	2.719 (69.1)	2.505 (63.6)	1.250 (31.8)	1.625 (41.3)

* Not available in Style M clamp. ** Not Applicable Style D

1. When maximum cable entry (page 21) is exceeded, Style 2 will be supplied. Dimensions F, G, H and J will not apply. Please consult factory.
2. O-Ring not supplied with Connector Designator A.
3. Backshells supplied with 600-052-* band, see Glenair Series 600 Tool Catalog for installation.

STYLE H
Heavy Duty (Table X)

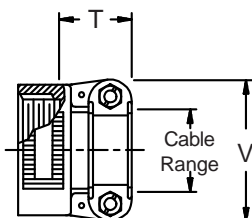

STYLE A
Medium Duty (Table XI)

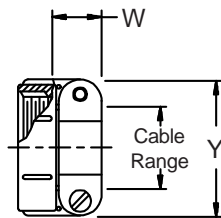

STYLE M
Medium Duty (Table XI)

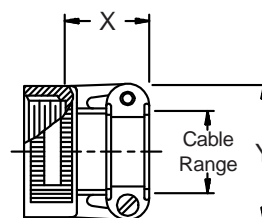

STYLE D
Medium Duty (Table XI)

