

CONNECTOR DESIGNATORS
A-F-H-L-S
ROTATABLE COUPLING

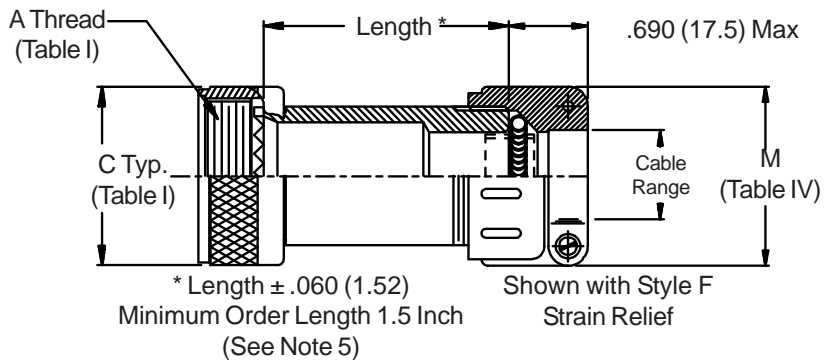

STYLE 2
(STRAIGHT
See Note 1)



STYLE 2
(45° & 90°
See Note 1)

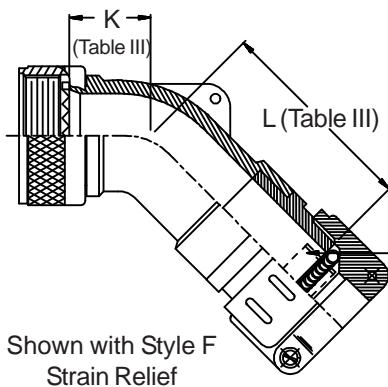

90° SPLIT
 Shown with Style G Strain Relief

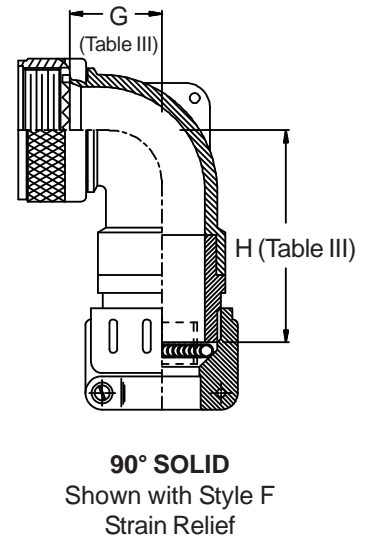
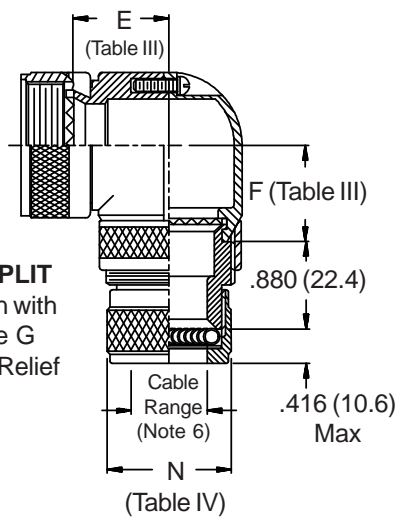

469-001-XX Shield Support Ring (order separately) is recommended for use in all G-Spring backshells (see page 463-8)

460-001
EMI/RFI Non-Environmental G-Spring Backshell
with Strain Relief
Rotatable Coupling - Low Profile



460

See inside back cover fold-out or pages 13 and 14 for Tables I and II.

TABLE III: ELBOW DIMENSIONS									
Shell Size		E Max	F Max	G Max	H Max	K Max	L Max	Conn. Desig.	
A-F-L-S	H								
08	09	.680 (17.3)	.560 (14.2)	.500 (12.7)	1.670 (42.4)	.413 (10.5)	1.720 (43.7)		
10	11	.750 (19.1)	.620 (15.7)	.595 (15.1)	1.790 (45.5)	.520 (13.2)	1.720 (43.7)		
12	13	.810 (20.6)	.690 (17.5)	.610 (15.5)	1.810 (46.0)	.582 (14.8)	1.780 (45.2)		
14	15	.870 (22.1)	.720 (18.3)	.700 (17.8)	1.880 (47.8)	.645 (16.4)	1.870 (47.5)		
16	17	.930 (23.6)	.820 (20.8)	.885 (22.5)	1.970 (50.0)	.738 (18.7)	1.980 (50.3)		
18	19	1.000 (25.4)	.880 (22.4)	.975 (24.8)	2.140 (54.4)	.926 (23.5)	2.170 (55.1)		
20	21	1.060 (26.9)	.940 (23.9)	.975 (24.8)	2.140 (54.4)	.926 (23.5)	2.170 (55.1)		
22	23	1.120 (28.4)	1.000 (25.4)	1.125 (28.6)	2.250 (57.2)	1.020 (25.9)	2.320 (58.9)		
24	25	1.180 (30.0)	1.060 (26.9)	1.125 (28.6)	2.250 (57.2)	1.020 (25.9)	2.320 (58.9)		
28		1.312 (33.3)	1.219 (31.0)	1.225 (31.1)	2.420 (61.5)	1.145 (29.1)	2.370 (60.2)		
32		1.562 (39.7)	1.483 (37.7)	1.575 (40.0)	2.670 (67.8)	1.207 (30.7)	2.470 (62.7)		
36		1.688 (42.9)	1.656 (42.1)	1.775 (45.1)	2.670 (67.8)	1.238 (31.4)	2.560 (65.0)		

TABLE IV: CABLE ENTRY					
Dash No.	M Max	N Max	Cable Range		
			Min	Max	
01	.843 (21.4)	.625 (15.9)	.156 (4.0)	.250 (6.4)	
02	.968 (24.6)	.750 (19.1)	.188 (4.8)	.375 (9.5)	
03	1.046 (26.6)	.875 (22.2)	.250 (6.4)	.438 (11.1)	
04	1.156 (29.4)	1.000 (25.4)	.280 (7.1)	.500 (12.7)	
05	1.218 (30.9)	1.125 (28.6)	.375 (9.5)	.625 (15.9)	
06	1.343 (34.1)	1.250 (31.8)	.500 (12.7)	.750 (19.1)	
07	1.468 (37.3)	1.375 (34.9)	.625 (15.9)	.875 (22.2)	
08	1.593 (40.5)	1.500 (38.1)	.750 (19.1)	1.000 (25.4)	
09	1.718 (43.6)	1.625 (41.3)	.875 (22.2)	1.125 (28.6)	
10	1.843 (46.8)	1.750 (44.5)	1.000 (25.4)	1.250 (31.8)	
11*	2.187 (55.5)	1.875 (47.6)	1.125 (28.6)	1.375 (34.9)	
12*	2.312 (58.7)	2.000 (50.8)	1.250 (31.8)	1.500 (38.1)	
13*	2.437 (61.9)	2.125 (54.0)	1.375 (34.9)	1.625 (41.3)	
14*	2.546 (64.7)	2.250 (57.2)	1.500 (38.1)	1.750 (44.5)	

* Consult factory for availability

1. Shield Support Ring (469-001-XX) is recommended for use in all G-Spring backshells (see page 463-8).
2. When maximum cable entry (page 21) is exceeded, Style 2 will be supplied. Dimensions E, F, G, H, K and L will not apply. Please consult factory.
3. Metric dimensions (mm) are indicated in parentheses.
4. Cable range is defined as the accommodations range for the wire bundle or cable. Dimensions shown are not intended for inspection criteria.
5. Consult factory for shorter lengths on straight backshells.
6. Maximum cable entry available for split elbow is 1.188 (30.2).