

**CONNECTOR DESIGNATORS**  
**A-B\*-C-D-E-F**  
**G-H-J-K-L-S**  
 \* Conn. Desig. B See Note 6  
**DIRECT COUPLING**

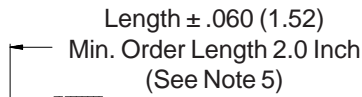

**STYLE 2**  
**(STRAIGHT)**  
 See Note 1)

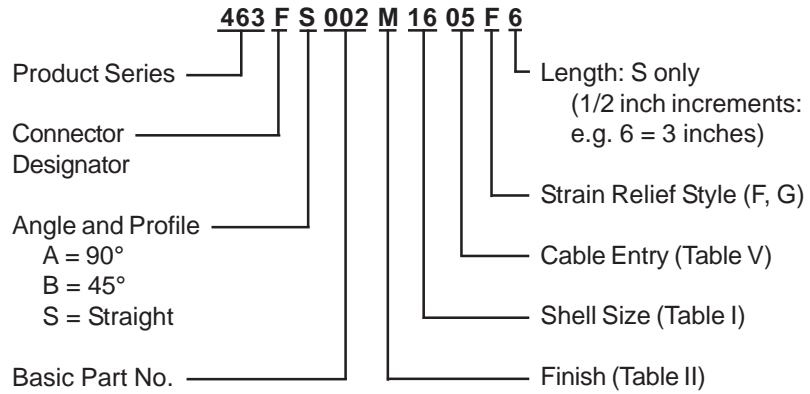
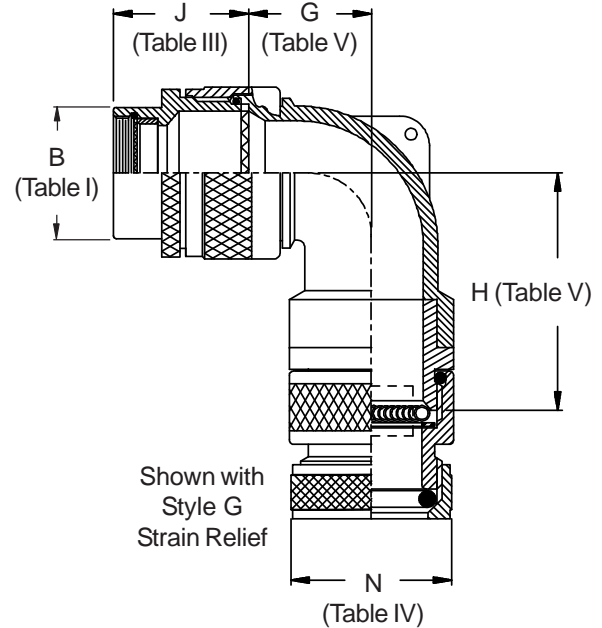
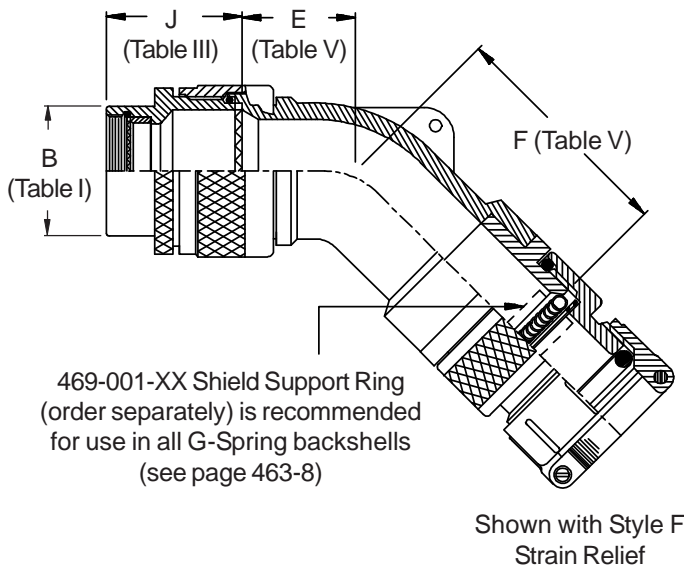
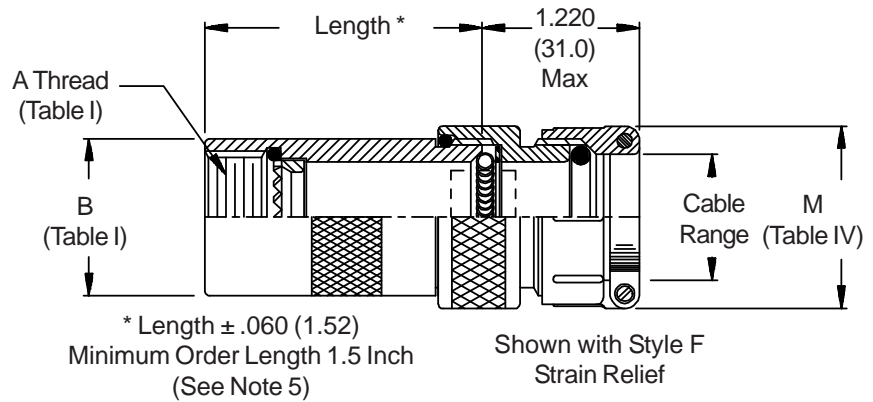

**463-002**  
**EMI/RFI Environmental G-Spring Backshell**  
with Strain Relief  
Direct Coupling - Low Profile



463

See inside back cover fold-out or pages 13 and 14 for Tables I and II.

TABLE III: FRONT ADAPTER			
Shell Size	J Max - Conn. Designator		
	A-E-F		
	J-H-L-S	D-B-G-K	C
08/09	1.180(30.0)	1.440(36.6)	
10/11	1.180(30.0)	1.440(36.6)	
12/13	1.180(30.0)	1.440(36.6)	1.735(44.1)
14/15	1.180(30.0)	1.440(36.6)	1.915(48.6)
16/17	1.380(35.0)	1.560(39.6)	1.915(48.6)
18/19	1.380(35.0)	1.560(39.6)	1.915(48.6)
20/21	1.380(35.0)	1.560(39.6)	1.915(48.6)
22/23	1.380(35.0)	1.560(39.6)	1.915(48.6)
24/25	1.380(35.0)	1.560(39.6)	1.915(48.6)
28/29	1.610(40.9)	1.560(39.6)	1.915(48.6)
32/33	1.610(40.9)	1.750(44.5)	1.915(48.6)
36	1.610(40.9)	1.750(44.5)	1.915(48.6)
40	1.610(40.9)	2.190(55.6)	1.915(48.6)

TABLE IV: CABLE ENTRY						
Dash No.	M Max	N Max	Cable Range			
			Min	Max	Min	Max
01	.843 (21.4)	.625 (15.9)	.125 (3.2)	.250 (6.4)		
02	.968 (24.6)	.750 (19.1)	.156 (4.0)	.375 (9.5)		
03	1.046 (26.6)	.875 (22.2)	.250 (6.4)	.438 (11.1)		
04	1.156 (29.4)	1.000 (25.4)	.280 (7.1)	.500 (12.7)		
05	1.218 (30.9)	1.125 (28.6)	.375 (9.5)	.625 (15.9)		
06	1.343 (34.1)	1.250 (31.8)	.500 (12.7)	.750 (19.1)		
07	1.468 (37.3)	1.375 (34.9)	.625 (15.9)	.875 (22.2)		
08	1.593 (40.5)	1.500 (38.1)	.750 (19.1)	1.000 (25.4)		
09	1.718 (43.6)	1.625 (41.3)	.875 (22.2)	1.125 (28.6)		
10	1.843 (46.8)	1.750 (44.5)	1.000 (25.4)	1.250 (31.8)		
11*	2.187 (55.5)	1.875 (47.6)	1.125 (28.6)	1.375 (34.9)		
12*	2.312 (58.7)	2.000 (50.8)	1.250 (31.8)	1.500 (38.1)		
13*	2.437 (61.9)	2.125 (54.0)	1.375 (34.9)	1.625 (41.3)		
14*	2.546 (64.7)	2.250 (57.2)	1.500 (38.1)	1.750 (44.5)		

\* Consult factory for availability

TABLE V: ELBOW DIMENSIONS						
Elbow Size	E		F		G	
	Max	Max	Max	Max	H Max	
01	.630 (16.0)	1.720 (43.7)	.636 (16.2)	1.670 (42.4)		
02	.630 (16.0)	1.720 (43.7)	.710 (18.0)	1.790 (45.5)		
03	.692 (17.6)	1.780 (45.2)	.734 (18.6)	1.810 (46.0)		
04	.755 (19.2)	1.870 (47.5)	.825 (21.0)	1.880 (47.8)		
05	.848 (21.5)	1.980 (50.3)	.988 (25.1)	1.970 (50.0)		
06	1.036 (26.3)	2.170 (55.1)	1.087 (27.6)	2.140 (54.4)		
07	1.036 (26.3)	2.170 (55.1)	1.087 (27.6)	2.140 (54.4)		
08	1.130 (28.7)	2.320 (58.9)	1.325 (33.7)	2.250 (57.2)		
09	1.130 (28.7)	2.320 (58.9)	1.325 (33.7)	2.250 (57.2)		
10	1.255 (31.9)	2.370 (60.2)	1.337 (34.0)	2.420 (61.5)		
11	1.317 (33.5)	2.470 (62.7)	1.827 (46.4)	2.670 (67.8)		
12	1.317 (33.5)	2.470 (62.7)	1.827 (46.4)	2.670 (67.8)		
13	1.348 (34.2)	2.560 (65.0)	2.027 (51.5)	2.670 (67.8)		
14	1.348 (34.2)	2.560 (65.0)	2.027 (51.5)	2.670 (67.8)		

1. Shield Support Ring (469-001-XX) is recommended for use in all G-Spring backshells (see page 463-8).
2. When maximum cable entry (page 22) is exceeded, Style 2 will be supplied. Angular Function S only.
3. Metric dimensions (mm) are indicated in parentheses.
4. Cable range is defined as the accommodations range for the wire bundle or cable. Dimensions shown are not intended for inspection criteria.
5. Consult factory for shorter lengths on straight backshells.
6. When using Connector Designator B refer to pages 18 and 19 for part number development.