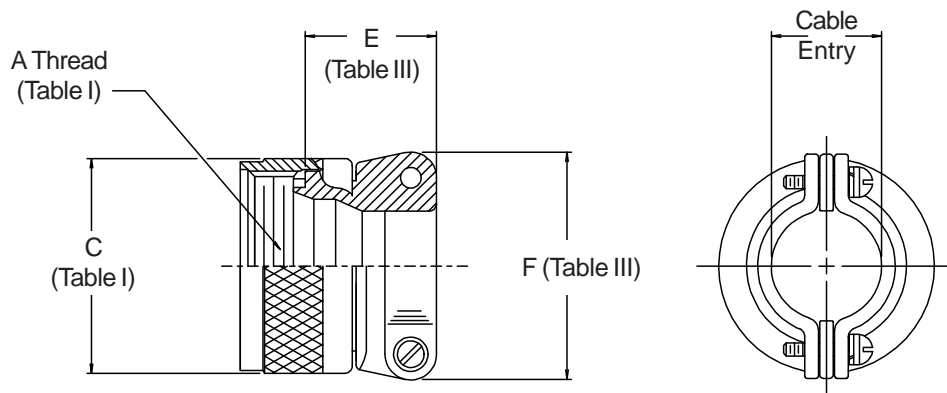
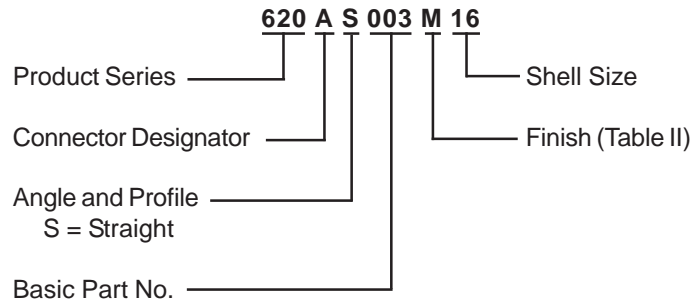

**CONNECTOR  
DESIGNATOR  
A-F-L-H-S  
ROTATABLE  
COUPLING**

**TABLE III: CABLE ENTRY**

Shell Size		E Max	F Nom	H Cable Entry			
A,F,L	H			Closed		Open	
08	09	.625 (15.9)	.750 (19.1)	.055 (1.4)	.125 (3.2)		
10	11	.656 (16.7)	.750 (19.1)	.055 (1.4)	.188 (4.8)		
12	13	.718 (18.2)	.937 (23.8)	.095 (2.4)	.250 (6.4)		
14	15	.968 (24.6)	1.015 (25.8)	.219 (5.6)	.375 (9.5)		
16	17	1.105 (28.1)	1.125 (28.6)	.219 (5.6)	.500 (12.7)		
18	19	1.105 (28.1)	1.188 (30.2)	.345 (8.8)	.625 (15.9)		
20	21	1.105 (28.1)	1.312 (33.3)	.469 (11.9)	.750 (19.1)		
22	23	1.105 (28.1)	1.437 (36.5)	.594 (15.1)	.875 (22.2)		
24	25	1.105 (28.1)	1.562 (39.7)	.594 (15.1)	1.000 (25.4)		
28		1.105 (28.1)	1.812 (46.0)	.859 (21.8)	1.250 (31.8)		

1. Cable Entry is defined as the accommodation entry for the wire bundle or cable. Dimensions are not intended for inspection criteria.
2. Metric dimensions (mm) are indicated in parentheses.