

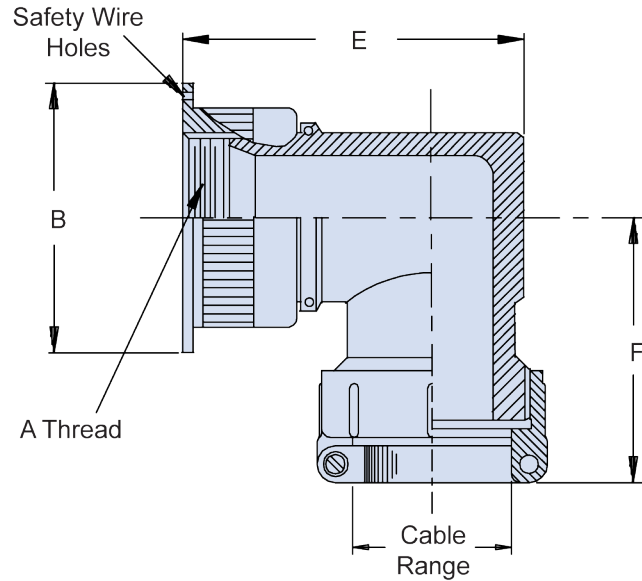
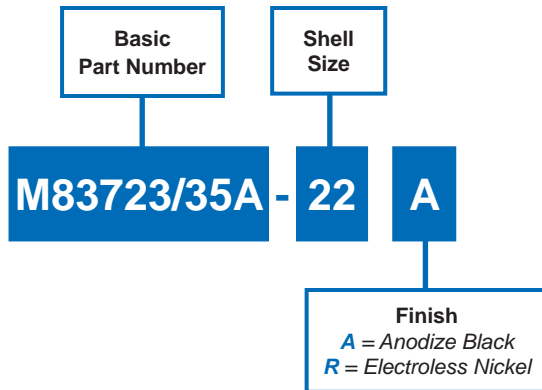

M83723/35A 90° Non-Environmental Strain Relief Backshell

CONNECTOR DESIGNATOR:
K MIL-DTL-83723 Series II

TABLE I: Shell Size, Cable Range and Dimensions

Shell Size	A Thread Class 2B	B Dia Max	E Max	F Max	Cable Range	
					Min	Max
08	.438 - 28 UNEF	.805 (20.4)	1.187 (30.1)	1.220 (31.0)	.102 (2.6)	.235 (6.0)
10	.500 - 28 UNEF	.890 (22.6)	1.187 (30.1)	1.250 (31.8)	.102 (2.6)	.235 (6.0)
11	.562 - 24 UNEF	.975 (24.8)	1.312 (33.3)	1.280 (32.5)	.140 (3.6)	.297 (7.5)
13	.625 - 24 UNEF	1.005 (25.5)	1.312 (33.3)	1.280 (32.5)	.140 (3.6)	.297 (7.5)
12	.625 - 24 UNEF	1.005 (25.5)	1.468 (37.3)	1.280 (32.5)	.140 (3.6)	.297 (7.5)
15	.750 - 20 UNEF	1.130 (28.7)	1.437 (36.5)	1.405 (35.7)	.195 (5.0)	.422 (10.7)
14	.750 - 20 UNEF	1.130 (28.7)	1.594 (40.5)	1.405 (35.7)	.195 (5.0)	.422 (10.7)
17	.875 - 20 UNEF	1.255 (31.9)	1.531 (38.9)	1.529 (38.8)	.255 (6.5)	.547 (13.9)
16	.875 - 20 UNEF	1.255 (31.9)	1.687 (42.8)	1.529 (38.8)	.255 (6.5)	.547 (13.9)
18	1.000 - 20 UNEF	1.350 (34.3)	1.765 (44.8)	1.593 (40.5)	.285 (7.2)	.610 (15.5)
20	1.125 - 18 UNEF	1.475 (37.5)	2.000 (50.8)	1.655 (42.0)	.350 (8.9)	.735 (18.7)
22	1.250 - 18 UNEF	1.600 (40.6)	2.000 (50.8)	1.718 (43.6)	.350 (8.9)	.735 (18.7)
24	1.375 - 18 UNEF	1.725 (43.8)	2.265 (57.5)	1.894 (48.1)	.468 (11.9)	.922 (23.4)
28	1.625 - 18 UNEF	1.975 (50.2)	2.265 (57.5)	1.973 (50.1)	.468 (11.9)	.922 (23.4)
32	1.875 - 16 UN	2.225 (56.5)	2.578 (65.5)	2.187 (55.5)	.664 (16.9)	1.235 (31.4)
36	2.125 - 16 UN	2.475 (62.9)	2.815 (71.5)	2.405 (61.1)	.694 (17.6)	1.360 (34.5)
40	2.375 - 16 UN	2.750 (69.9)	5.800 (147.3)	5.100 (129.5)	.911 (23.1)	1.630 (41.4)

APPLICATION NOTES

- For complete dimensions see the applicable Military Specification.
- Metric dimensions (mm) are in parentheses.
- Cable Range is defined as the accommodation range for the wire bundle or cable. Dimensions shown are not intended for inspection criteria.

Dimensions in inches (millimeters) and are subject to change without notice.