

STYLE T - TOP ENTRY

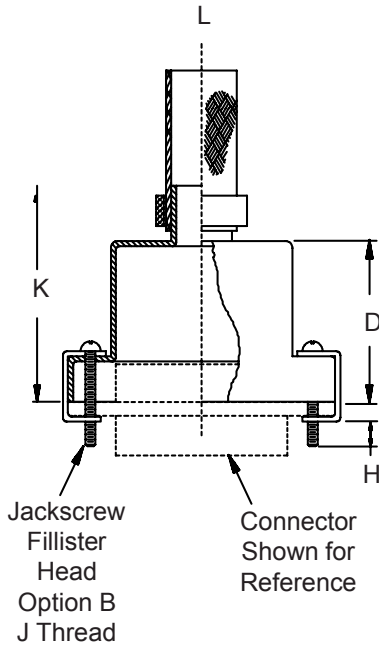

STYLE S - SIDE ENTRY

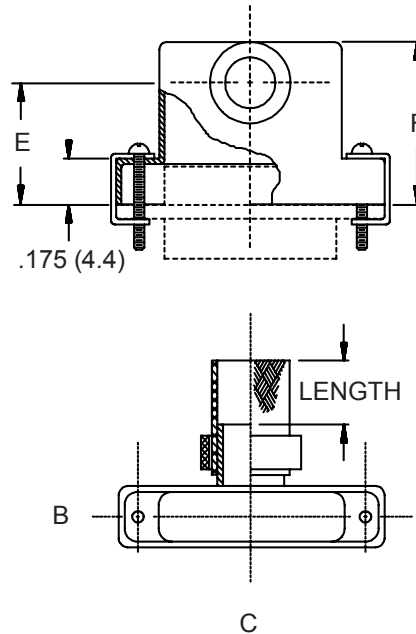

STYLE E - 45° ENTRY

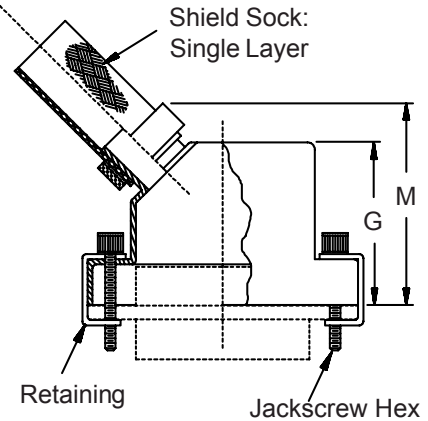

Metric dimensions (mm) are indicated in parentheses.

HOW TO ORDER

Series	Cable Entry Style	Basic Part Number	Shell* Plating	Shell Size (Table I)	Hardware Options *	Cable Entry (Table II)	Shield Sock Length
500	T – Top	011	C – Black Anodize	9	B – (2) Male Fillister Head Jackscrews	04	Length in 1 inch increments (e.g. 6 = 6 inches)
	S – Side		E – Chem. Film	15	H – (2) Male Hex Socket	05	
500	E – 45°	011	J – Gold Iridite Over Cadmium Over Electroless Nickel	21	F – (2) Female Jackpost	06	
			M – Electroless Nickel	31	FB – (1) Female Jackpost And (1) Male Jackpost	07	
			NF – Cadmium, Olive Drab Over Electroless Nickel	37	FH – (1) Female Jackpost and (1) Male Hex Socket	08	
			Z2 – Gold	51		09	
				100		10	
						11	
						12	
Sample Part Number:							
500	T	011	M	21	B	06	— 6

* SEE PAGE C-4 FOR COMPLETE INFORMATION

500-011
EMI/RFI Micro-D Backshell
with Shield Sock



MIL-DTL-83513
 Micro-D

TABLE I: DIMENSIONS

Shell Size	A	B	C	D	E	F
09	.775 (19.7)	.36 (9.1)	.565 (14.4)	.32 (8.1)	.435 (11.0)	.607 (15.4)
15	.925 (23.5)	.36 (9.1)	.715 (18.2)	.44 (11.2)	.440 (11.2)	.643 (16.3)
21	1.075 (27.3)	.36 (9.1)	.865 (22.0)	.56 (14.2)	.458 (11.6)	.677 (17.2)
25	1.175 (29.8)	.36 (9.1)	.965 (24.5)	.62 (15.7)	.483 (12.3)	.718 (18.2)
31	1.325 (33.7)	.36 (9.1)	1.115 (28.3)	.68 (17.3)	.476 (12.1)	.726 (18.4)
37	1.475 (37.5)	.36 (9.1)	1.265 (32.1)	.72 (18.3)	.478 (12.2)	.744 (18.9)
51	1.425 (36.2)	.40 (10.2)	1.215 (30.9)	.75 (19.1)	.548 (13.9)	.829 (21.1)
100	2.160 (54.9)	.45 (11.4)	1.800 (45.7)	.81 (20.6)	.687 (17.4)	.984 (25.0)

Shell Size	G	H REF	J Thread	K ±.03 (0.8)	M Max	Max Entry Table II
09	.650 (16.5)	.154 (3.9)	2-56 UNC-2	.75 (19.1)	1.00 (25.4)	08
15	.700 (17.8)	.154 (3.9)	2-56 UNC-2	.88 (22.4)	1.03 (26.2)	08
21	.735 (18.7)	.154 (3.9)	2-56 UNC-2	1.00 (25.4)	1.05 (26.7)	08
25	.800 (20.3)	.154 (3.9)	2-56 UNC-2	1.06 (26.9)	1.09 (27.7)	08
31	.860 (21.8)	.154 (3.9)	2-56 UNC-2	1.12 (28.4)	1.13 (28.7)	09
37	.925 (23.5)	.154 (3.9)	2-56 UNC-2	1.16 (29.5)	1.16 (29.5)	09
51	.975 (24.8)	.154 (3.9)	2-56 UNC-2	1.19 (30.2)	1.19 (30.2)	10
100	1.050 (26.7)	.184 (4.7)	4-40 UNC-2	1.25 (31.8)	1.25 (31.8)	12

TABLE II: CABLE ENTRY

Dash No.	L Entry
04	.125 (3.2)
05	.156 (4.0)
06	.188 (4.8)
07	.219 (5.6)
08	.250 (6.4)
09	.281 (7.1)
10	.312 (7.9)
11	.344 (8.7)
12	.375 (9.5)

Metric dimensions (mm) are indicated in parentheses.