

AS85049/104

Composite 45° RFI/EMI Shield-Sock Adapter with Detented or Non-Detented Self-Locking Coupling Nut

CONNECTOR DESIGNATOR:

H MIL-DTL-38999 Series III and IV

**Product Series and
Basic Part Number**
**Shell Size
(Table I)**
M85049/104
- 11
N
*N = Non-Detented Self-Locking
(Omit for Detented Self-Locking)
(See Note 6)*

319

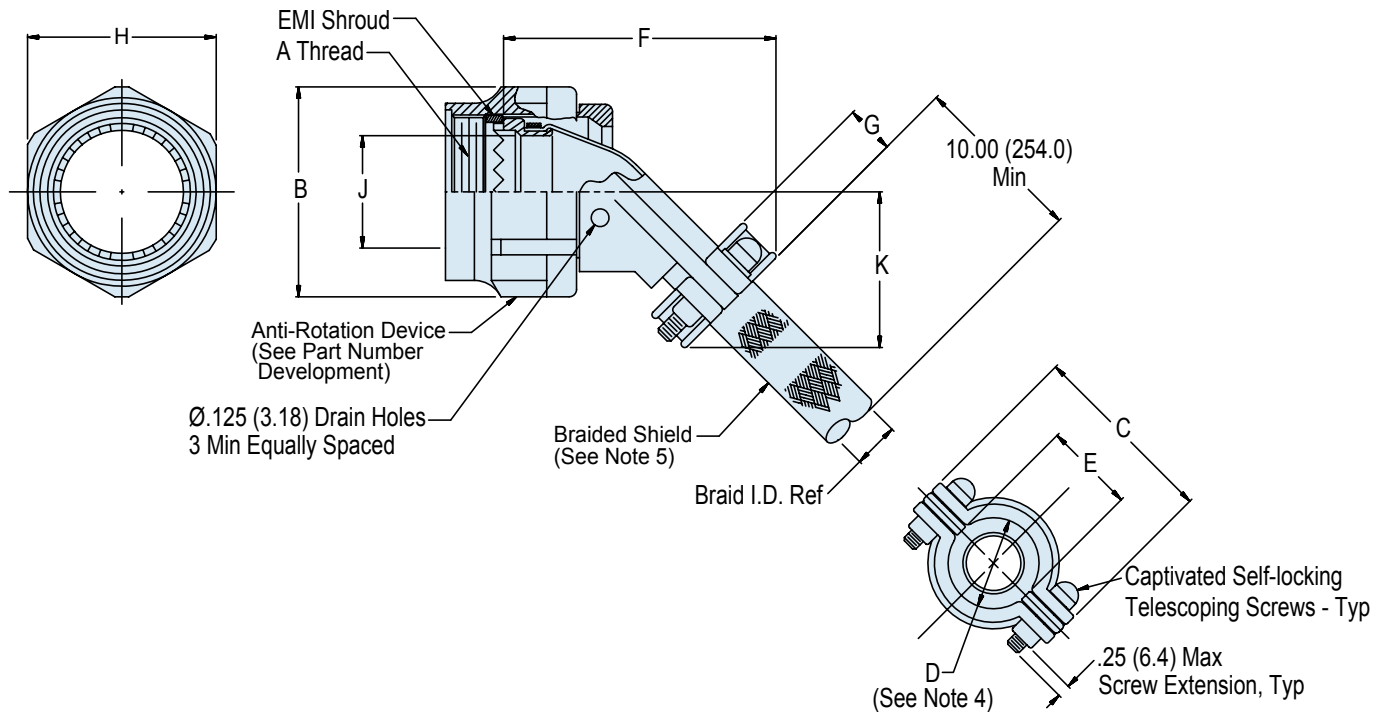

APPLICATION NOTES

- For complete dimensions see the applicable Military Specification.
- Metric dimensions (mm) are in parentheses.
- Glenair 600 Series backshell assembly tools are recommended for assembly and installation.
- Cable entry is measured with saddle bars closed and bottomed on clamp ears.
- For shield/splice termination use AS85049/93 split support ring.
- Detented self-locking has a positive audible detented coupling.
- Material/Finish:
Clamp body, coupling nut, saddles - High grade engineering thermoplastic/N.A.
Clamp hardware - CRES/passivated, silver plated, mfg option
Anti-rotation device - Corrosion resistant material
Braid - Copper/nickel plated
Interface ring and shroud - Brass/nickel plated
Braid retention device - See Table II

AS85049/104
Composite 45° RFI/EMI Shield-Sock Adapter
with Detented or Non-Detented Self-Locking Coupling Nut



TABLE I: Shell Size and Dimensions

Shell Size	A Thread Class 2B	B Max	C Max	D ± .031 (0.79) See Note 4	E Min	F Max	G ± .030 (0.76)	H Hex	J Min	K Max	Braid I.D. Ref	Screw Size
09	M12 X 1 - 6H	.858 (21.79)	.98 (24.89)	.265 (6.73)	.229 (5.82)	1.388 (35.26)	.375 (9.53)	.750/.736 (19.05/18.69)	.264 (6.71)	.901 (22.89)	.375 (9.53)	4-40
11	M15 X 1 - 6H	.984 (24.99)	1.05 (26.67)	.310 (7.87)	.274 (6.96)	1.428 (36.27)	.375 (9.53)	.875/.860 (22.23/21.84)	.390 (9.91)	.964 (24.39)	.375 (9.53)	4-40
13	M18 X 1 - 6H	1.157 (29.39)	1.20 (30.48)	.390 (9.91)	.354 (8.99)	1.498 (38.05)	.406 (10.31)	1.000/.980 (25.40/24.89)	.504 (12.80)	1.050 (26.67)	.500 (12.70)	6-32
15	M22 X 1 - 6H	1.280 (32.51)	1.30 (33.02)	.506 (12.85)	.470 (11.94)	1.548 (39.32)	.406 (10.31)	1.125/1.100 (31.75/31.09)	.630 (16.00)	1.112 (28.24)	.500 (12.70)	6-32
17	M25 X 1 - 6H	1.406 (35.71)	1.44 (36.58)	.591 (15.01)	.555 (14.10)	1.648 (41.86)	.406 (10.31)	1.250/1.224 (31.75/31.09)	.756 (19.20)	1.175 (29.85)	.781 (19.84)	6-32
19	M28 X 1 - 6H	1.516 (38.51)	1.56 (39.62)	.661 (16.79)	.625 (15.88)	1.768 (44.91)	.406 (10.31)	1.375/1.348 (34.93/34.24)	.843 (21.41)	1.230 (31.24)	.781 (19.84)	6-32
21	M31 X 1 - 6H	1.642 (41.71)	1.69 (42.93)	.744 (18.90)	.708 (17.98)	1.808 (45.92)	.406 (10.31)	1.500/1.469 (38.10/37.31)	.969 (24.61)	1.293 (32.84)	1.000 (25.40)	6-32
23	M34 X 1 - 6H	1.768 (44.91)	1.77 (44.96)	.826 (20.98)	.790 (20.07)	1.858 (47.19)	.406 (10.31)	1.625/1.581 (41.28/40.16)	1.091 (27.71)	1.365 (34.67)	1.000 (25.40)	6-32
25	M37 X 1 - 6H	1.890 (48.01)	1.89 (48.01)	.896 (22.76)	.860 (21.84)	1.898 (48.21)	.406 (10.31)	1.750/1.690 (44.45/42.93)	1.217 (30.91)	1.417 (35.99)	1.250 (31.75)	6-32

Table II (Manufacturer's Option)

Material	Finish
Aluminum Alloy	Iridite per AMS-C-5541
Stainless Steel	Passivated
Copper	Tin Plate