

**CONNECTOR  
 DESIGNATOR**  
**G**  
**ROTATABLE  
 COUPLING**

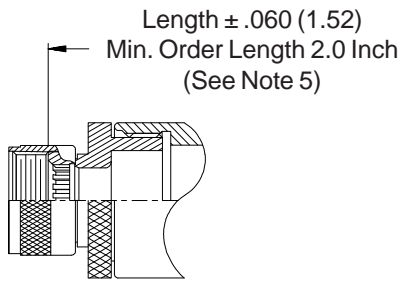

**STYLE 2  
 (STRAIGHT  
 See Note 1)**

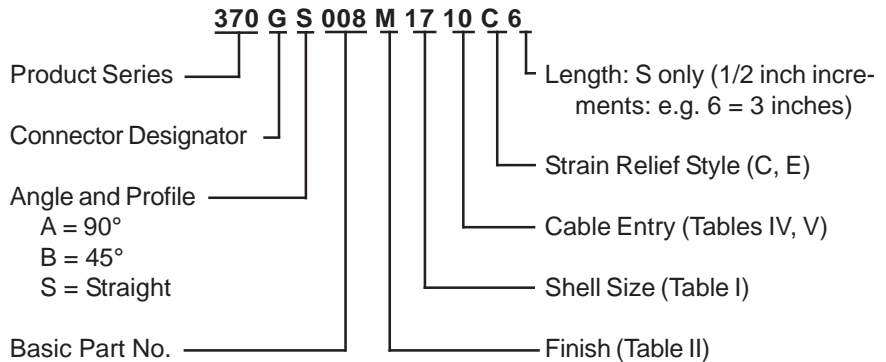
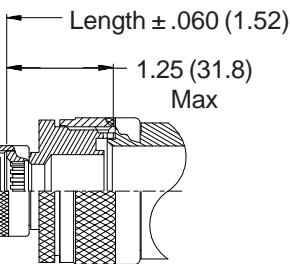
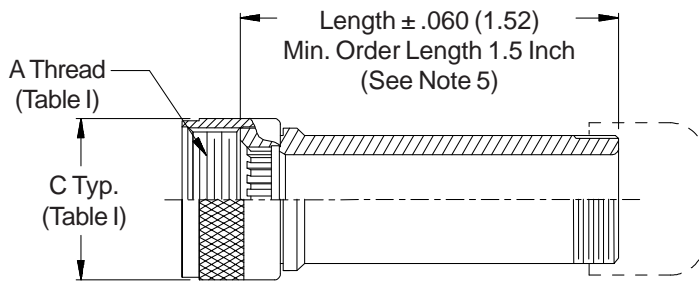

**STYLE 2  
 (45° & 90°  
 See Note 1)**

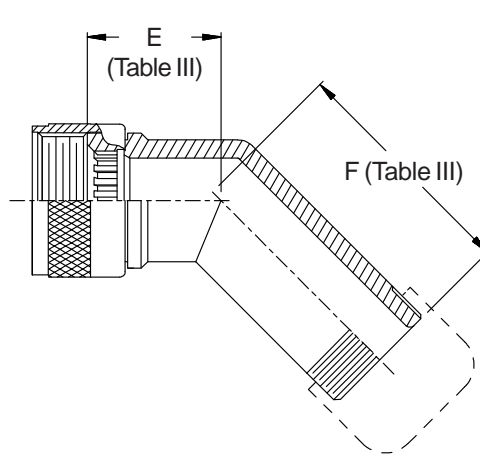

**STYLE C  
 Medium Duty  
 (Table IV)**

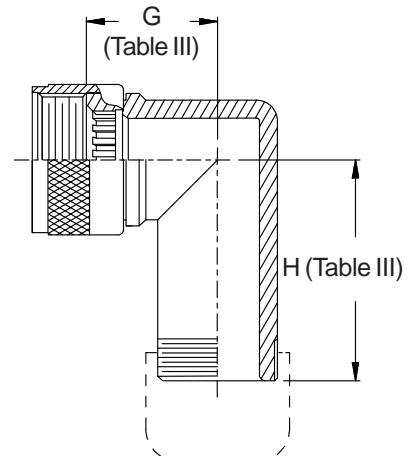

**STYLE E  
 Medium Duty  
 (Table V)**

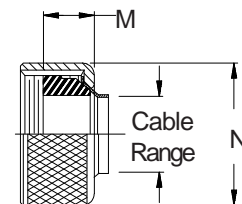
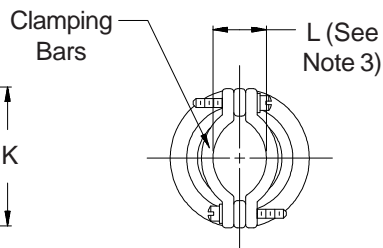
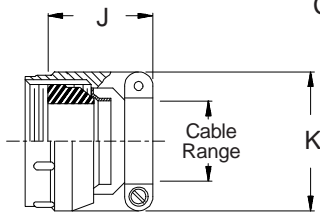

**370-008**  
**Water-Tight Cable Sealing Backshell**  
with Strain Relief  
**Standard Profile - Rotatable Coupling**



See inside back cover fold-out or pages 13 and 14 for unabridged Tables I and II.

**TABLE III: ELBOW DIMENSIONS**

Shell Size	E Max	F Max	G Max	H Max
11	1.240 (31.5)	.920 (23.4)	1.380 (35.1)	1.060 (26.9)
13	1.260 (32.0)	.940 (23.9)	1.440 (36.6)	1.120 (28.4)
15	1.290 (32.8)	.970 (24.6)	1.500 (38.1)	1.190 (30.2)
17	1.310 (33.3)	.990 (25.1)	1.570 (39.9)	1.250 (31.8)
19	1.340 (34.0)	1.020 (25.9)	1.630 (41.4)	1.330 (33.8)
23	1.380 (35.1)	1.060 (26.9)	1.730 (43.9)	1.410 (35.8)
25	1.410 (35.8)	1.090 (27.7)	1.800 (45.7)	1.480 (37.6)
29	1.580 (40.1)	1.260 (32.0)	2.040 (51.8)	1.720 (43.7)
33	1.620 (41.1)	1.300 (33.0)	2.130 (54.1)	1.810 (46.0)

**TABLE II: STANDARD FINISHES**

GLENAIR SYMBOL	FINISH
B	Cadmium Plate, Olive Drab
C	Anodize, Black
G	Hard Coat, Anodic
M	Electroless Nickel
NF	Cadmium Plate, Olive Drab Over Electroless Nickel

See Inside Back Cover for Additional Finish Options

**TABLE IV: CABLE ENTRY**

Dash No.	J Max	K Max	L Ref	Cable Range	
				Min	Max
03	1.219 (31.0)	.812 (20.6)	.135 (3.4)	.156 (4.0)	.219 (5.6)
04	1.219 (31.0)	.937 (23.8)	.203 (5.2)	.188 (4.8)	.312 (7.9)
06	1.219 (31.0)	1.062 (27.0)	.285 (7.2)	.281 (7.1)	.438 (11.1)
08	1.219 (31.0)	1.188 (30.2)	.350 (8.9)	.312 (7.9)	.531 (13.5)
10	1.281 (32.5)	1.312 (33.3)	.390 (9.9)	.375 (9.5)	.625 (15.9)
12	1.281 (32.5)	1.562 (39.7)	.460 (11.7)	.500 (12.7)	.750 (19.1)
16	1.406 (35.7)	1.750 (44.5)	.510 (13.0)	.625 (15.9)	.938 (23.8)
20	1.656 (42.1)	2.250 (57.2)	.695 (17.7)	.938 (23.8)	1.250 (31.8)
24	1.906 (48.4)	2.375 (60.3)	.715 (18.2)	1.000 (25.4)	1.375 (34.9)
28	1.906 (48.4)	2.625 (66.7)	.915 (23.2)	1.250 (31.8)	1.625 (41.3)
32	2.000 (50.8)	2.812 (71.4)	1.070 (27.2)	1.500 (38.1)	1.875 (47.6)

**TABLE V: CABLE ENTRY**

Dash No.	M Max	N Max	Cable Range	
			Min	Max
03	.739 (18.8)	.812 (20.6)	.156 (4.0)	.219 (5.6)
04	.739 (18.8)	.937 (23.8)	.188 (4.8)	.312 (7.9)
06	.739 (18.8)	1.062 (27.0)	.281 (7.1)	.438 (11.1)
08	.739 (18.8)	1.188 (30.2)	.312 (7.9)	.531 (13.5)
10	.791 (20.1)	1.312 (33.3)	.375 (9.5)	.625 (15.9)
12	.880 (22.4)	1.562 (39.7)	.500 (12.7)	.750 (19.1)
16	.901 (22.9)	1.750 (44.5)	.625 (15.9)	.938 (23.8)
20	1.031 (26.2)	2.250 (57.2)	.938 (23.8)	1.250 (31.8)
24	1.250 (31.8)	2.375 (60.3)	1.000 (25.4)	1.375 (34.9)
28	1.250 (31.8)	2.625 (66.7)	1.250 (31.8)	1.625 (41.3)
32	1.312 (33.3)	2.812 (71.4)	1.500 (38.1)	1.875 (47.6)

1. When maximum cable entry (page 21) is exceeded, Style 2 will be supplied. Dimensions E, F, G & H will not apply. Please consult factory.
2. Metric dimensions (mm) are indicated in parentheses.
3. Saddles are bottomed on Clamp Ears.
4. Cable range is defined as the accommodations range for the wire bundle or cable. Dimensions shown are not intended for inspection criteria.
5. Consult factory for shorter lengths on straight backshells.

**-445** Add "-445" to Specify Glenair's Non-Detent, ("NESTOR") Spring-Loaded, Self-Locking Coupling. See Page 41 for Details.