

**CONNECTOR
 DESIGNATORS
 A-F-H-L-S
 ROTATABLE
 COUPLING
 TYPE E INDIVIDUAL
 AND/OR OVERALL
 SHIELD TERMINATION**

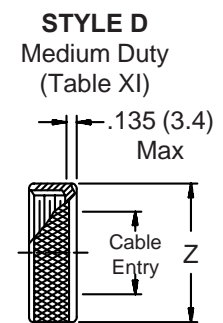

380-018
EMI/RFI Non-Environmental Backshell
 with Strain Relief
 Type E - Rotatable Coupling - Split Shell

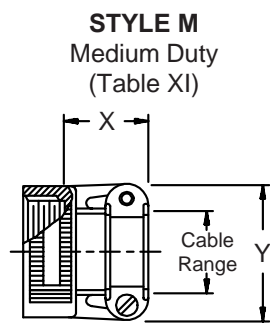
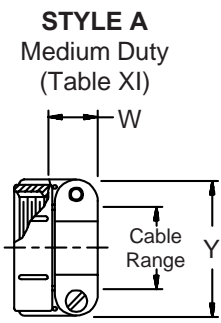
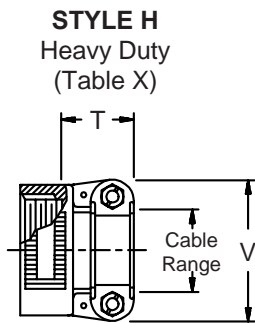
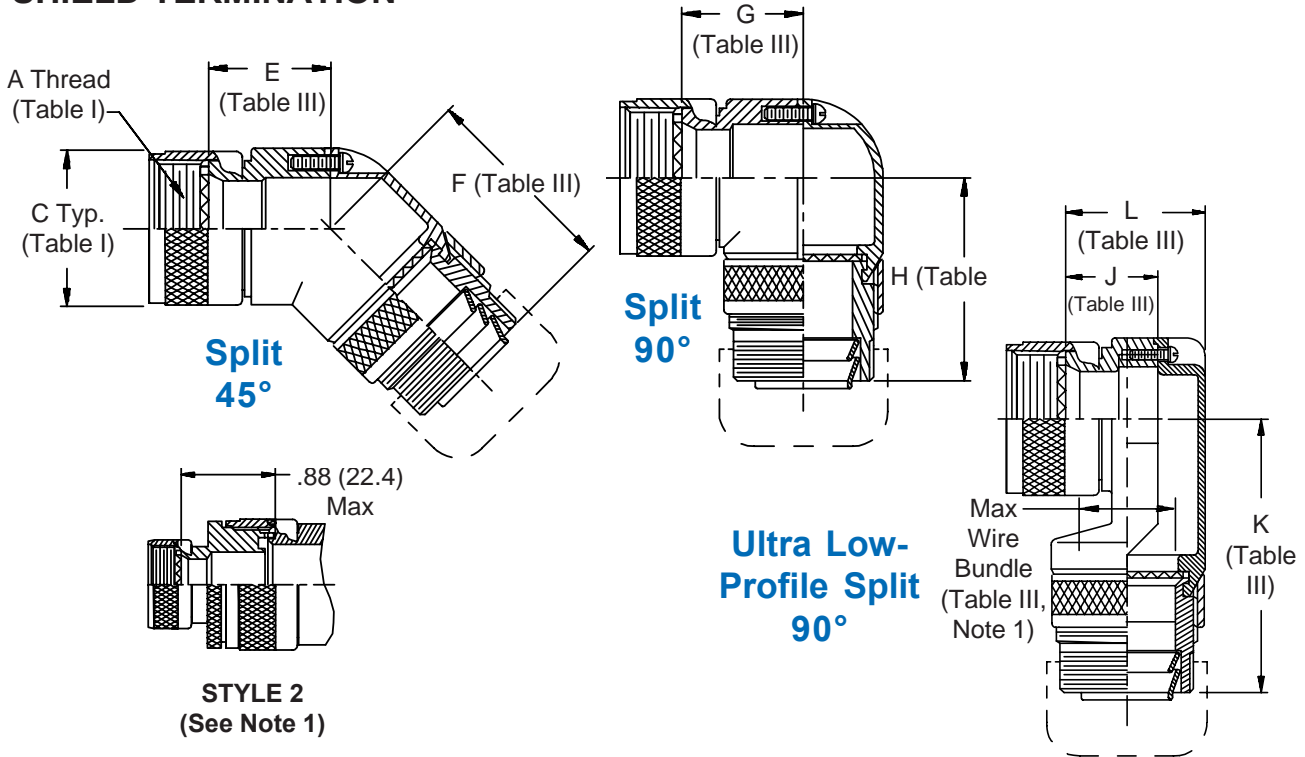
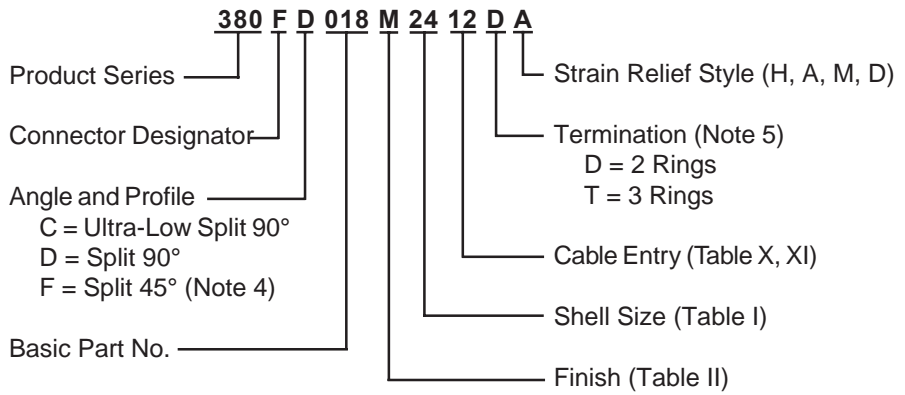

See inside back cover fold-out or pages 13 and 14 for unabridged Tables I and II.

TABLE III: ELBOW DIMENSIONS

Shell Size	E	F	G	H	J	K	L	Function C
	Max	Max	Max	Max	Max	Max	Max	Max Wire Bundle
08/09	.440 (11.2)	1.590 (40.4)	.680 (17.3)	1.530 (38.9)	.340 (8.6)	1.840 (46.7)	.681 (17.3)	.250 (6.4)
10/11	.500 (12.7)	1.650 (41.9)	.750 (19.1)	1.590 (40.4)	.270 (6.9)	2.000 (50.8)	.731 (18.6)	.375 (9.5)
12/13	.560 (14.2)	1.720 (43.7)	.810 (20.6)	1.660 (42.2)	.270 (6.9)	2.000 (50.8)	.731 (18.6)	.375 (9.5)
14/15	.620 (15.7)	1.750 (44.5)	.870 (22.1)	1.690 (42.9)	.280 (7.1)	2.070 (52.6)	.831 (21.1)	.500 (12.7)
16/17	.680 (17.3)	1.850 (47.0)	.930 (23.6)	1.790 (45.5)	.420 (10.7)	2.120 (53.8)	.981 (24.9)	.625 (15.9)
18/19	.750 (19.1)	1.910 (48.5)	1.000 (25.4)	1.850 (47.0)	.640 (16.3)	2.150 (54.6)	1.181 (30.0)	.625 (15.9)
20/21	.820 (20.8)	1.970 (50.0)	1.060 (26.9)	1.910 (48.5)	.640 (16.3)	2.150 (54.6)	1.181 (30.0)	.625 (15.9)
22/23	.880 (22.4)	2.030 (51.6)	1.120 (28.4)	1.970 (50.0)	.540 (13.7)	2.300 (58.4)	1.181 (30.0)	.750 (19.1)
24/25	.940 (23.9)	2.090 (53.1)	1.180 (30.0)	2.030 (51.6)	.540 (13.7)	2.300 (58.4)	1.181 (30.0)	.750 (19.1)

TABLE X: CABLE ENTRY

Dash No.	T Max	V Max	Cable Range	
			Min	Max
04	.780 (19.8)	.957 (24.3)	.125 (3.2)	.312 (7.9)
06	.780 (19.8)	1.145 (29.1)	.250 (6.4)	.437 (11.1)
08	.780 (19.8)	1.332 (33.8)	.312 (7.9)	.562 (14.3)
10	.780 (19.8)	1.332 (33.8)	.350 (8.9)	.625 (15.9)
12	.811 (20.6)	1.551 (39.4)	.500 (12.7)	.750 (19.1)
16	.905 (23.0)	1.770 (45.0)	.625 (15.9)	.937 (23.8)
20	1.092 (27.7)	2.113 (53.7)	.875 (22.2)	1.250 (31.8)
24	1.124 (28.5)	2.363 (60.0)	1.000 (25.4)	1.375 (34.9)
28	1.399 (35.5)	2.770 (70.4)	1.250 (31.8)	1.625 (41.3)
32	1.399 (35.5)	3.020 (76.7)	1.437 (36.5)	1.875 (47.6)

- When maximum cable entry (page 21) is exceeded, Style 2 will be supplied (not available in Function C). Dimensions E, F, G and H will not apply. Please consult factory.
- Metric dimensions (mm) are indicated in parentheses.
- Cable range is defined as the accommodations range for the wire bundle or cable. Dimensions shown are not intended for inspection criteria.

- Consult factory for available sizes of 45° (Symbol F).
- Designate termination symbol T for 3 ring termination of individual and overall braid. Designate D for standard 2 ring termination of individual or overall braid.
- Angular function "C", low-profile split elbow, not available with "S" connector designator.

TABLE II: STANDARD FINISHES

GLENAIR SYMBOL	FINISH
B	Cadmium Plate, Olive Drab
M	Electroless Nickel
NF	Cadmium Plate, Olive Drab Over Electroless Nickel
See Inside Back Cover for Additional Finish Options	

TABLE XI: CABLE ENTRY

Dash No.	W Max	X Max	Y Max	Z Max	Cable Range	
					Min **	Max
03*	.437 (11.1)	.760 (19.3)	.843 (21.4)	.630 (16.0)	.156 (4.0)	.250 (6.4)
04*	.437 (11.1)	.760 (19.3)	.906 (23.0)	.755 (19.2)	.188 (4.8)	.312 (7.9)
06*	.500 (12.7)	.760 (19.3)	1.093 (27.8)	.942 (23.9)	.281 (7.1)	.438 (11.1)
08	.563 (14.3)	.760 (19.3)	1.187 (30.1)	1.067 (27.1)	.344 (8.7)	.562 (14.3)
10	.563 (14.3)	.760 (19.3)	1.281 (32.5)	1.192 (30.3)	.375 (9.5)	.625 (15.9)
12	.563 (14.3)	.760 (19.3)	1.500 (38.1)	1.380 (35.1)	.438 (11.1)	.750 (19.1)
16	.656 (16.7)	1.073 (27.3)	1.719 (43.7)	1.535 (39.0)	.562 (14.3)	.938 (23.8)
20	.656 (16.7)	1.323 (33.6)	2.062 (52.4)	1.848 (46.9)	.750 (19.1)	1.250 (31.8)
24	.656 (16.7)	1.323 (33.6)	2.312 (58.7)	2.255 (57.3)	.781 (19.8)	1.375 (34.9)
28	1.188 (30.2)	1.572 (39.9)	2.719 (69.1)	2.505 (63.6)	.969 (24.6)	1.625 (41.3)
32*	1.187 (30.1)	1.572 (39.9)	2.969 (75.4)	2.755 (70.0)	1.125 (28.6)	1.875 (47.6)
40*	1.125 (28.6)	1.572 (39.9)	3.531 (89.7)	3.255 (82.7)	1.469 (37.3)	2.375 (60.3)

* Not available in Style M clamp.

** Not Applicable Style D