

AS85049/109

Straight RFI/EMI Shield-Sock Metal Shrink Boot Adapter with Optional Detented or Non-Detented Self-Locking or Non-Self-Locking Coupling Nut

CONNECTOR DESIGNATOR:

A

AS50151 Series AS34001
 MIL-DTL-26482 Series II
 AS81703 Series III
 MIL-DTL-83723 Series I & III
 40M39569, DEF 5326-3
 EN 2997, EN 3646
 ESC 10, ESC 11, LN 29504
 NFC93422 Series HE302
 PAN 6432-1, PAN 6432-2
 PATT 602

B

Product Series and
Basic Part Number

M85049/109

Shell Size
(Table I)

S

Shield Finish
(Table IV)

10

T

Entry Size
(Table II)

W

Drain Hole
(Omit for None)

03

-

6

D

S = Detented, Self-Locking
 - = Non-Self-Locking (Use Dash)
 N = Non-Detented, Self-Locking

Finish
(Table III)

Braid Length
 1 Inch Increments,
 6" Min., 18" Max

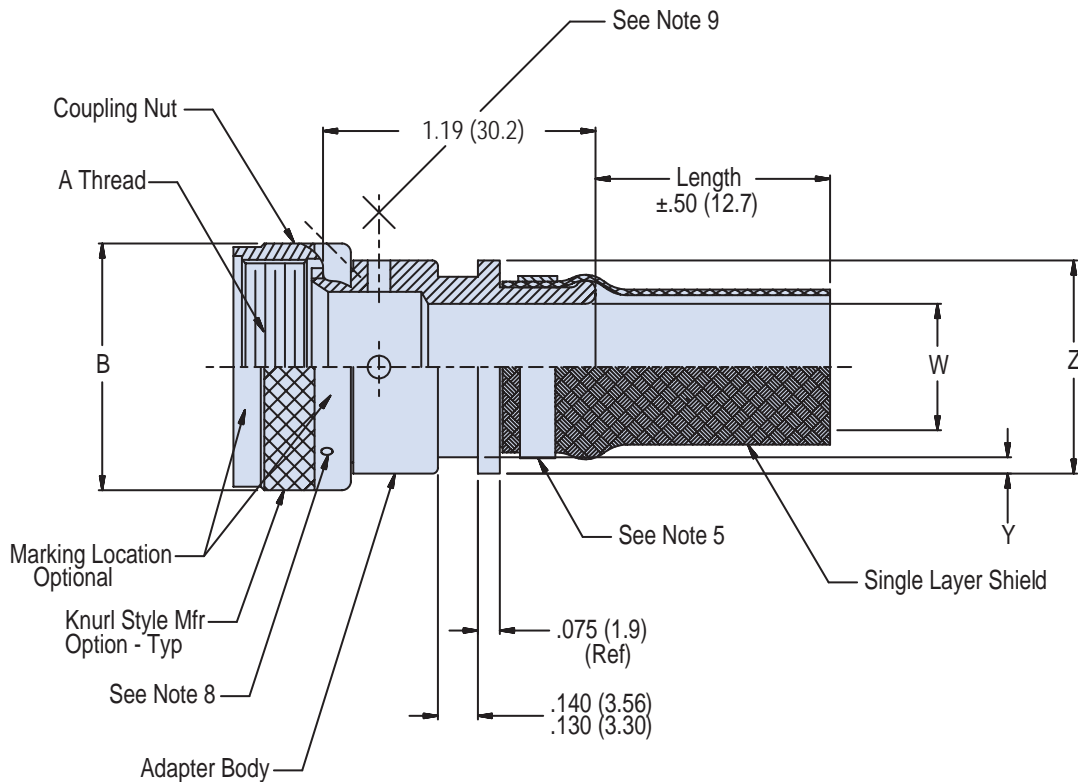

Dimensions in inches (millimeters) and are subject to change without notice.

AS85049/109
Straight RF/EMI Shield-Sock Metal
Shrink Boot Adapter with Optional Detented or Non-Detented
Self-Locking or Non-Self-Locking Coupling Nut



AS85049

B

TABLE I: Shell Size, Entry Size, Thread and Dimensions

Accessory Shell Size Code	Allowable Cable Entry Size	Shell Size AS81703, Series III (Ref)	Shell Size MIL-DTL-26482, Series II MIL-DTL-83723, Series III (Ref)	Shell Size MIL-DTL-5015, Series I and II (Ref)	A Thread Class 2B	B Max Diameter
03	01	3	-	-	9/16-24 UNEF	.855 (22.48)
08	01	-	8	8S	1/2-20 UNF	.885 (22.48)
10	01-03	-	10	10S & 10SL	5/8-24 UNEF	1.010 (25.65)
12	01-05	7	12	12S & 12	3/4-20 UNEF	1.135 (28.83)
14	02-06	12	14	14S & 14	7/8-20 UNEF	1.260 (32.00)
16	04-08	19	16	16S & 16	1-20 UNEF	1.385 (35.18)
18	05-09	27	18	18	1 1/16-18 UNEF	1.510 (38.35)
20	07-11	37	20	20	1 3/16-18 UNEF	1.635 (41.53)
22	09-13	-	22	22	1 5/16-18 UNEF	1.760 (44.70)
24	11-14	-	24	24	1 7/16-18 UNEF	1.885 (47.88)
28	14-16	-	-	28	1 3/4-18 UNS	2.135 (54.23)
32	16-17	-	-	32	2-18 UNS	2.395 (60.83)
36	17-19	-	-	36	2 1/4-16 UN	2.635 (66.93)
40	19-21	-	-	40	2 1/2-16 UN	2.885 (73.28)
44	21-23	-	-	44	2 3/4-16 UN	3.135 (76.63)
48	23-25	-	-	48	3-16 UN	3.385 (85.98)
61	12-14	61	-	-	1 1/2-18 UNEF	1.885 (47.88)

TABLE II: Entry Size and Dimensions

Entry Size	W ± .020 (.51)	Y +.008 (.20) - .000 (.00)	Z Max
01	.250 (6.4)	.044 (1.12)	.560 (14.2)
02	.312 (7.9)	.044 (1.12)	.630 (16.0)
03	.375 (9.5)	.044 (1.12)	.690 (17.5)
04	.438 (11.1)	.044 (1.12)	.750 (19.1)
05	.500 (12.7)	.044 (1.12)	.820 (20.8)
06	.562 (14.3)	.044 (1.12)	.890 (22.6)
07	.625 (15.9)	.044 (1.12)	.950 (24.1)
08	.688 (17.5)	.044 (1.12)	1.020 (25.9)
09	.750 (19.1)	.069 (1.75)	1.120 (28.4)
10	.812 (20.6)	.069 (1.75)	1.200 (30.5)
11	.875 (22.2)	.069 (1.75)	1.270 (32.3)
12	.938 (23.8)	.069 (1.75)	1.260 (32.0)
13	1.000 (25.4)	.069 (1.75)	1.370 (34.8)
14	1.125 (28.6)	.069 (1.75)	1.470 (37.3)
15	1.250 (31.8)	.069 (1.75)	1.600 (40.6)
16	1.375 (34.9)	.069 (1.75)	1.710 (43.4)
17	1.500 (38.1)	.086 (2.18)	1.840 (46.7)
18	1.625 (41.3)	.086 (2.18)	2.000 (50.8)
19	1.750 (44.5)	.086 (2.18)	2.120 (53.8)
20	1.875 (47.6)	.086 (2.18)	2.270 (57.7)
21	2.000 (50.8)	.086 (2.18)	2.440 (62.0)
22	2.125 (54.0)	.086 (2.18)	2.600 (66.0)
23	2.250 (57.2)	.086 (2.18)	2.750 (69.9)
24	2.375 (60.3)	.086 (2.18)	2.900 (73.7)
25	2.500 (63.5)	.086 (2.18)	3.060 (77.7)

Table III: Symbol and Finish

Symbol	Finish
N	Electroless Nickel
W	Cadmium/Olive Drab over Electroless Nickel (1000 Hour Salt Spray)
X	Nickel Fluorocarbon Polymer
Z	Zinc Nickel

Table IV: Symbol and Finish

Symbol	Finish
K	Nickel Plate
T	Tin Plate

Table V: (Manufacturer's Option)

Material	Finish
Copper	Tin Plate
Stainless Steel	Passivated

APPLICATION NOTES

- Metric equivalents are given for general information only and are based on 1.000 inch (25.40 mm).
- Dimensions are in inches and apply after plating. Accessory configuration is optional within the specified dimension envelope.
- Adapter length is measured from the bottom of the accessory teeth to the adapter that is covered by the braid. The adapter surface under the braid shall be ribbed knurled or have a surface roughness of .125 R minimum in accordance with ANSI B46.1.
- Pig tail terminated braid material shall be in accordance with Table IV. Braid length is defined by Note 1 as shown in the part or identifying number (PIN).
- Termination band configuration is not controlled. Band with buckle may exceed the "Z" dimension (See Table II) provided the band does not interfere with boot attachment, band material shall be specified as in Table V.
- Shrink boot (when required) shall be as specified in AS5258.
- Termination of the accessory shield with harness shield may be performed with a AS85049/93 shield support ring or similar split ring accessory types.
- Three (3) holes equally spaced shall be provided and accommodate .020 (.51) maximum safety wire for the non-self-locking coupling configuration.
- Drain holes will be provided with a .125 (3.2 mm) diameter, 4 places equally spaced (optional, see part number development).
- Material/Finish:
 Adapter, coupling nut - Al alloy/See Table III
 Band - See Table V, manufacturer's option
 Braid - Copper/See Table IV

Dimensions in inches (millimeters) and are subject to change without notice.