

# AS85049/5 Style 1 Straight Environmental Backshell



AS85049

B

### CONNECTOR DESIGNATOR:

**C** MIL-DTL-22992 Classes C, J and R

### Finish

**A** = Black Anodize  
**W** = Cadmium, Olive Drab  
**Y** = Pure Dense Electrodeposited Aluminum  
**X** = Nickel Fluorocarbon Polymer  
**Z** = Zinc Nickel

**M85049/5**

**W**

**10**

**A**

**1**

Basic Part Number

Dash Number (Table II)

Type A or B

Style 1

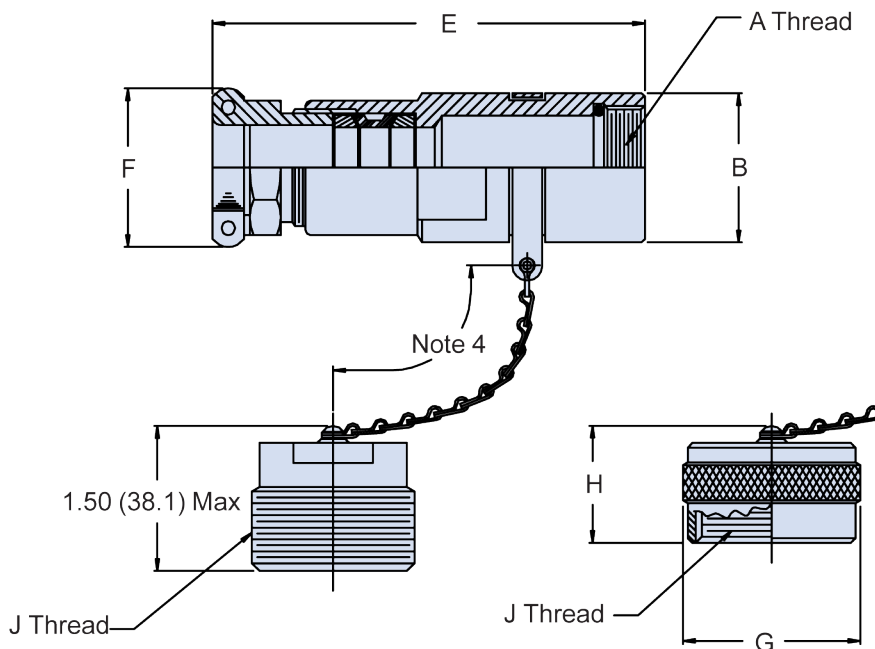

**TYPE A - Plug Cap**  
For use with MS17344

**TYPE B - Receptacle Cap**  
For use with MS17343,  
MS17345, and MS17347

### APPLICATION NOTES

1. For complete dimensions see the applicable Military Specification.
2. Metric dimensions (mm) are in parentheses.
3. Cable Range is defined as the accommodation range for the wire bundle or cable. Dimensions shown are not intended for inspection criteria.
4. Approximate chain lengths: Dash No. 01-12 = 5.0 (127.0); Dash No. 13-29 = 6.0 (152.4).

Dimensions in inches (millimeters) and are subject to change without notice.



# AS85049/5 Style 1 Straight Environmental Backshell

TABLE I: Shell Size and Dimensions

Shell Size	A Thread Class 2B-LH	B Dia ±.015 (0.4)	G Dia Max	H Max	J Thread (Plated) Class 2 (A or B)
12	.7500 - 20 UNEF	.933 (23.7)	1.094 (27.8)	.765 (19.4)	0.875-0.1P-0.2L-DS
18	1.1250 - 18 UNEF	1.307 (33.2)	1.469 (37.3)	.980 (24.9)	1.250-0.1P-0.2L-DS
20	1.2500 - 18 UNEF	1.433 (36.4)	1.562 (39.7)	.980 (24.9)	1.375-0.1P-0.2L-DS
22	1.3750 - 18 UNEF	1.557 (39.5)	1.688 (42.9)	.980 (24.9)	1.500-0.1P-0.2L-DS
24	1.6250 - 18 UNEF	1.807 (45.9)	1.938 (49.2)	.980 (24.9)	1.750-0.1P-0.2L-DS
28	1.8750 - 16 UN	2.057 (52.2)	2.219 (56.4)	.980 (24.9)	2.000-0.1P-0.2L-DS
32	2.0625 - 16 UNS	2.307 (58.6)	2.469 (62.7)	.980 (24.9)	2.250-0.1P-0.2L-DS
36	2.3125 - 16 UNS	2.557 (64.9)	2.719 (69.1)	.980 (24.9)	2.500-0.1P-0.2L-DS
40	2.6250 - 16 UN	2.870 (72.9)	2.969 (75.4)	.980 (24.9)	2.750-0.1P-0.2L-DS
44	2.8750 - 16 UN	3.120 (79.2)	3.217 (81.7)	.980 (24.9)	3.000-0.1P-0.2L-DS

TABLE II: Dash Number and Cable Range

Dash No.	Shell Size	E Max	F ± .031 (0.8)	Cable Range	
				Min	Max
1	12	3.182 (80.8)	.938 (23.8)	.156 (4.0)	.250 (6.4)
2	18	3.901 (99.1)	1.062 (27.0)	.281 (7.1)	.375 (9.5)
3	18	3.932 (99.9)	1.125 (28.6)	.281 (7.1)	.375 (9.5)
4	18	3.901 (99.1)	1.062 (27.0)	.188 (4.8)	.281 (7.1)
5	18	4.177 (106.1)	1.375 (34.9)	.511 (13.0)	.605 (15.4)
6	18	4.177 (106.1)	1.375 (34.9)	.436 (11.1)	.530 (13.5)
7	20	4.489 (114.0)	1.562 (39.7)	.605 (15.4)	.699 (17.8)
8	20	4.489 (114.0)	1.562 (39.7)	.361 (9.2)	.455 (11.6)
9	20	4.306 (109.4)	1.375 (34.9)	.511 (13.0)	.605 (15.4)
10	22	4.584 (116.4)	1.688 (42.9)	.449 (11.4)	.562 (14.3)
11	22	4.306 (109.4)	1.375 (34.9)	.311 (7.9)	.405 (10.3)
12	22	4.306 (109.4)	1.375 (34.9)	.715 (18.2)	.828 (21.0)
13	24	4.647 (118.0)	1.812 (46.0)	.787 (20.0)	.900 (22.9)
14	24	4.647 (118.0)	1.812 (46.0)	.517 (13.1)	.630 (16.0)
15	24	4.647 (118.0)	1.812 (46.0)	.637 (16.2)	.750 (19.1)
16	24	4.647 (118.0)	1.812 (46.0)	.857 (21.8)	.970 (24.6)
17	24	4.542 (115.4)	1.688 (42.9)	.715 (18.2)	.828 (21.0)
18	24	4.647 (118.0)	1.812 (46.0)	.692 (17.6)	.805 (20.4)
19	28	4.896 (124.4)	2.125 (54.0)	.755 (19.2)	.880 (22.4)
20	28	4.896 (124.4)	2.125 (54.0)	.984 (25.0)	1.109 (28.2)
21	28	4.647 (118.0)	1.812 (46.0)	.637 (16.2)	.750 (19.1)
22	28	4.229 (107.4)	1.125 (28.6)	.281 (7.1)	.375 (9.5)
23	28	4.647 (118.0)	1.812 (46.0)	.857 (21.8)	.970 (24.6)
24	28	4.896 (124.4)	2.125 (54.0)	.875 (22.2)	1.000 (25.4)
25	28	4.431 (112.5)	1.375 (34.9)	.436 (11.1)	.530 (13.5)
26	28	4.647 (118.0)	1.812 (46.0)	.567 (14.4)	.680 (17.3)
27	32	4.896 (124.4)	2.125 (54.0)	.930 (23.6)	1.055 (26.8)
28	32	4.959 (126.0)	2.469 (62.7)	1.105 (28.1)	1.230 (31.2)
29	32	4.647 (118.0)	1.812 (46.0)	.637 (16.2)	.750 (19.1)
30	32	4.896 (124.4)	2.125 (54.0)	.755 (19.2)	.880 (22.4)
31	32	4.896 (124.4)	2.125 (54.0)	.984 (25.0)	1.109 (28.2)
32	32	4.647 (118.0)	1.812 (46.0)	.857 (21.8)	.970 (24.6)
33	32	4.276 (108.6)	1.125 (28.6)	.281 (7.1)	.375 (9.5)
34	32	4.431 (112.5)	1.375 (34.9)	.436 (11.1)	.530 (13.5)
35	32	4.959 (126.0)	2.469 (62.7)	1.005 (25.5)	1.130 (28.7)
36	36	4.959 (126.0)	2.469 (62.7)	1.185 (30.1)	1.310 (33.3)
37	36	4.896 (124.4)	2.125 (54.0)	.984 (25.0)	1.109 (28.2)
38	36	5.021 (127.5)	2.625 (66.7)	1.250 (31.8)	1.375 (34.9)
39	36	4.959 (126.0)	2.469 (62.7)	1.055 (26.8)	1.180 (30.0)
40	36	5.021 (127.5)	2.625 (66.7)	1.320 (33.5)	1.445 (36.7)
41	36	4.651 (118.1)	1.812 (46.0)	.857 (21.8)	.970 (24.6)
42	36	4.959 (126.0)	2.469 (62.7)	1.105 (28.1)	1.230 (31.2)
43	40	6.354 (161.4)	3.171 (80.5)	1.815 (46.1)	1.940 (49.3)
44	40	6.354 (161.4)	3.171 (80.5)	1.700 (43.2)	1.825 (46.4)
45	40	6.354 (161.4)	3.171 (80.5)	1.605 (40.8)	1.730 (43.9)
46	40	6.057 (153.8)	2.953 (75.0)	1.531 (38.9)	1.656 (42.1)
47	44	6.345 (161.2)	3.375 (85.7)	1.867 (47.4)	2.000 (50.8)
48	44	5.266 (133.8)	3.171 (80.5)	1.775 (45.1)	1.900 (48.3)

Dimensions in inches (millimeters) and are subject to change without notice.