

M300 ASSEMBLY TOOL Z300-902

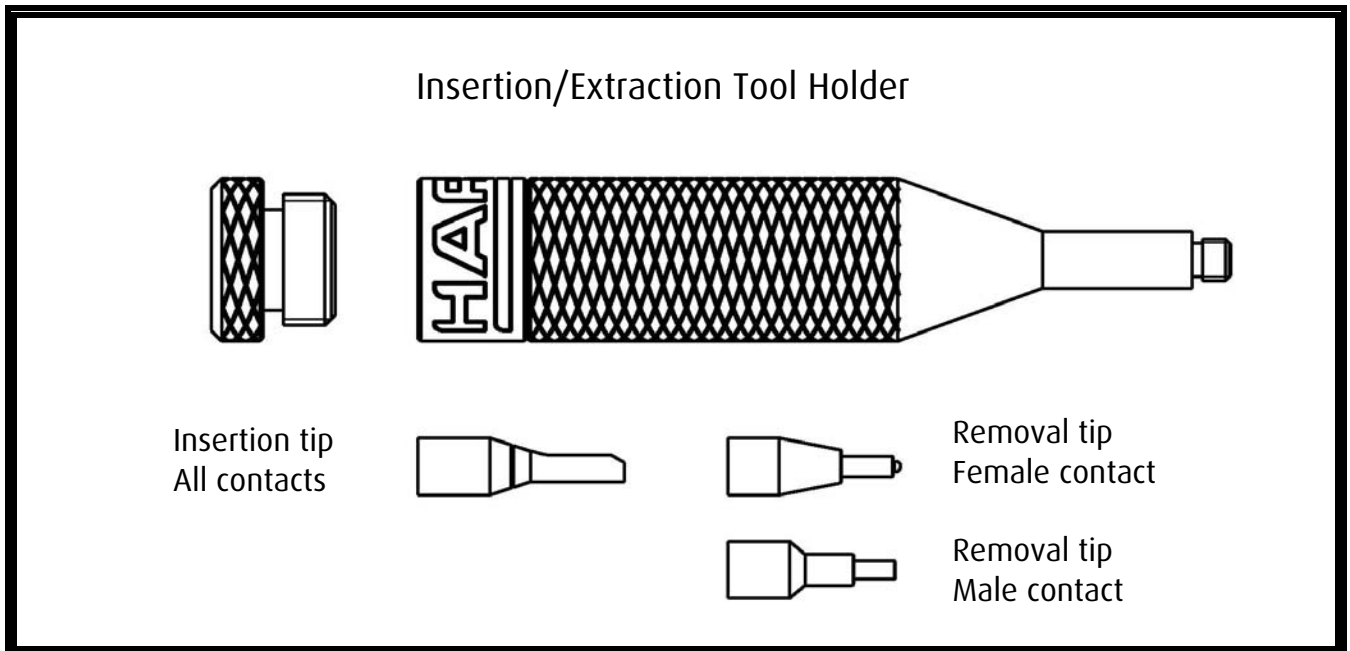

INSERTION PROCEDURE

1. Strip the wire and crimp the contact on to the wire, ensuring that the correct part is used (see Instruction Sheet IS-01, Hand Crimp Tool M22520/2-01).
2. Ensure all parts (moulding and crimp sockets) are clean and ready for final assembly.
3. Select the insertion tip for the tool and attach to the handle. The different tools can be found by unscrewing the cap at the end of the handle (see above for tool identification).
4. Place the crimped contact partially into the moulding. The correct position is reached when approximately 1.2-1.6mm of contact protrudes (see Figures 2 and 3).
5. Place the insertion tool over the wire, with the wire sitting in the groove and the tool resting on the back of the crimped socket (see Figure 1).
6. To complete the assembly, push firmly on the rear of the contact while ensuring the tool remains perpendicular to the mould face. There will be an audible click when the contact is correctly seated within the moulding.
7. Repeat steps 4 to 6 until the moulding is populated as required. Care should be taken not to damage any contacts. It is recommended that the moulding be supported by a small fixture (like an unpopulated mating moulding in a vice) or a hard flat surface. Do not support the mould on any Jack Screws fitted, or pressure exerted on inserting the contacts will not be evenly distributed.

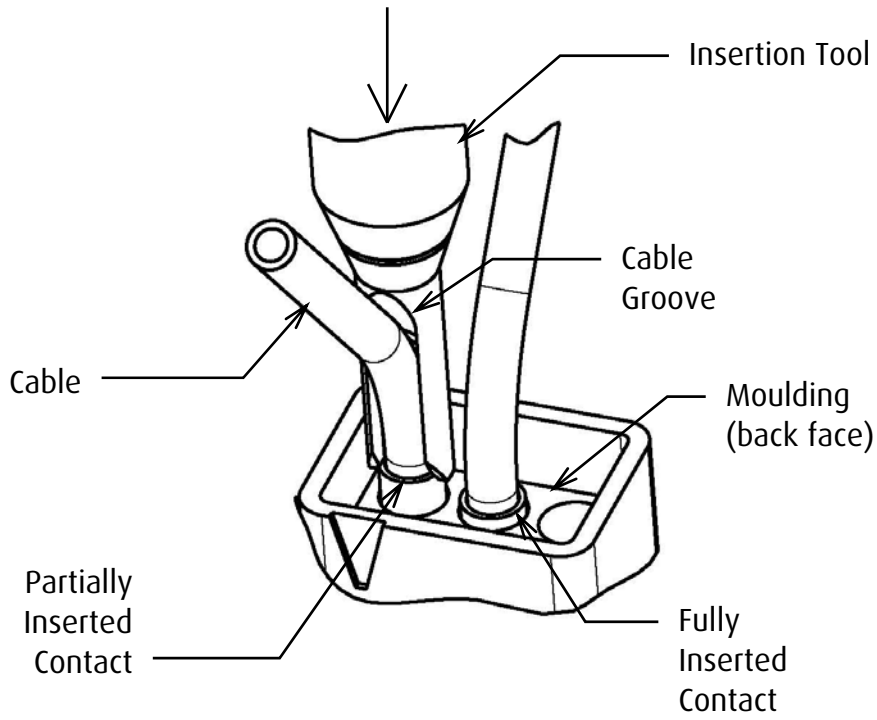

Figure 1

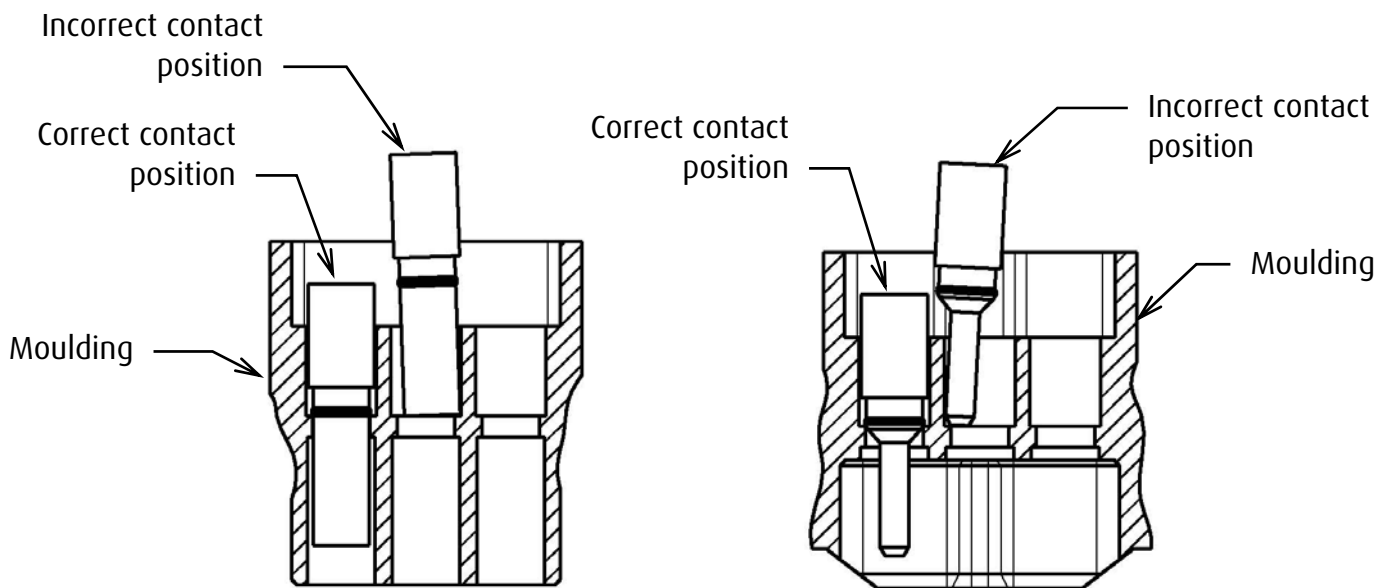

Figure 2
(Female contact position prior to final 'click-in')

Figure 3
(Male contact position prior to final 'click-in')

EXTRACTION PROCEDURE

To remove a contact from the moulding, select the appropriate Extraction Tool from the handle and attach as before. Place this tool over the mating end of the contact and push firmly. Care should be taken to keep the tool perpendicular to the mould face, or mould damage may occur.

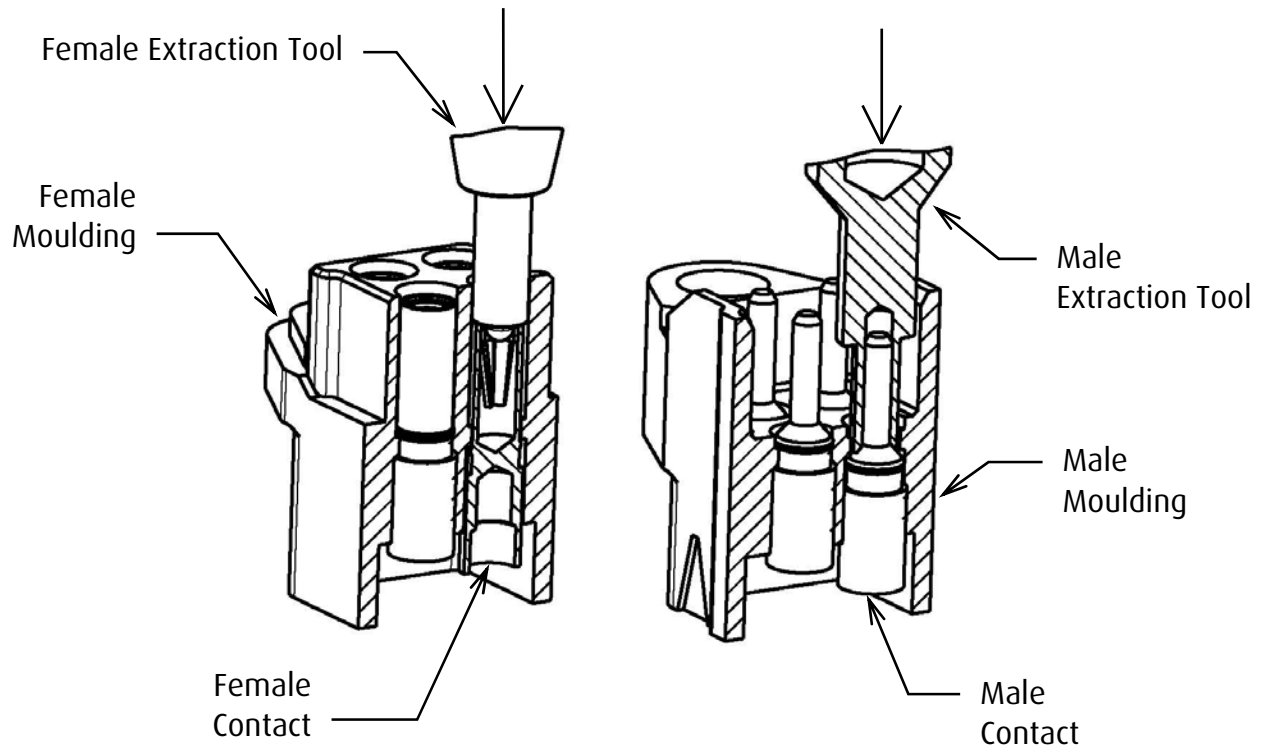

Figure 4

Notes:

- 1) Different Tool Tip for Female and Male
- 2) Contacts can be extracted and replaced in housing 2 times. Re-use of a housing that has had a contact replaced more than 2 times is not recommended.