

"Stay Connected with" HEYware



ALL NEW PRODUCTS!

STANDARD PACK 1,000/BAG



- Designed for fast and easy installation and removal - simply push to fasten and pull to release.
- Ideal for frequent maintenance work.
- Typical applications include metal enclosures, telecom equipment, appliances and electrical equipment.

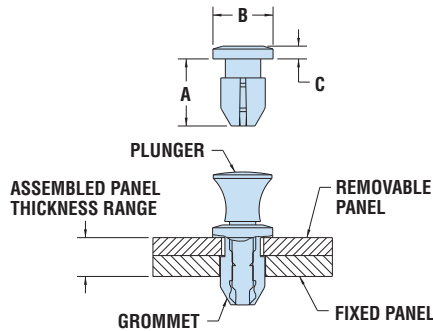

Heyco® Snap Latch Rivets

Grommet

FIXED PANEL HOLE DIAMETER	REMOVABLE PANEL THICKNESS	PART NO.		DESCRIPTION	MATING PLUNGER		PART DIMENSIONS					
		Black	White		Black	White	A Body Length		B Head Diameter		C Head Height	
in. mm.	in. mm.						in. mm.	in. mm.	in. mm.	in. mm.	in. mm.	
.253 6,4	.043 1,1	12283	12284	HSLG-1M	12261	12262	.31 8,0	.33 8,5	.07 1,8	.33 8,5	.07 1,8	
	.063 1,6	12285	12286	HSLG-2M	12263	12264	.33 8,5					
	.098 2,5	12287	12288	HSLG-3M	12265	12266	.37 9,5					
	.161 4,1	12289	12290	HSLG-4M	12267	12268	.43 11,0					

Standard colors black and white.

Plunger

REMOVABLE PANEL HOLE DIAMETER	ASSEMBLED PANEL THICKNESS RANGE				PART NO.		DESCRIPTION	MATING GROMMET	
	Minimum	Maximum	Black	White	Black	White			
in. mm.	in. mm.	in. mm.	in. mm.						
.237 6,0	.059 1,5	.146 3,7	12261	12262	HSLPB-1M	12283	12284		
	.079 2,0	.165 4,2	12263	12264	HSLPB-2M	12285	12286		
	.118 3,0	.205 5,2	12265	12266	HSLPB-3M	12287	12288		
	.181 4,6	.272 6,9	12267	12268	HSLPB-4M	12289	12290		

Standard colors black and white.



- One-piece, all plastic expansion rivet.
- Designed to securely fasten a wide variety of materials in a range of applications.
- Inserts quickly from either side of assembly.
- Use with standard rivet setting tool - pull the pin through the body and panels are drawn together.
- Head breaks off even with pin and leaves an attractive, finished appearance.
- Effective for soft materials such as rubber, padded fabrics, etc.

Heyco® Expansion Rivets

Mounting Hole Dia.	WILL FIT THESE PANELS Assembled Panel Thickness				PART NO.	DESCRIPTION	PART DIMENSIONS					
	Minimum	Maximum	Black				A Length		B Head Height		C Head Diameter	
in. mm.	in. mm.	in. mm.	in. mm.	Black		in. mm.	in. mm.	in. mm.	in. mm.	in. mm.		
EXR Style 1												
.157 4,0	.059 1,5	.177 4,5	12230	EXR 177-157	.73 18,5	.10 2,5	.31 8,0					
	.118 3,0	.157 4,0	12231	EXR-157-197	.65 16,5	.07 1,8	.35 8,9					
.197 5,0	.236 6,0	.394 10,0	12232	EXR 236-197	.79 20,0	.07 1,8	.47 12,0					
	.236 6,0	.394 10,0	12233	EXR 394-197	.98 25,0	.07 1,8	.47 12,0					
.236 6,0	.157 4,0	.335 8,5	12235	EXR 335-236	1.10 28,0	.10 2,5	.51 13,0					
.240 6,1	.157 4,0	.311 7,9	12237	EXR 311-240	1.14 29,0	.10 2,5	.67 16,9					
.248 6,3	.295 7,5	.453 11,5	12238	EXR 453-248	1.26 31,9	.10 2,5	.67 16,9					
	EXR Style 2											
.130 3,3	.039 1,0	.138 3,5	12650	EXR 138-130	.25 6,4	.06 1,4	.25 6,4					
	.138 3,5	.256 6,5	12651	EXR 256-130	.38 9,6	.06 1,4	.25 6,4					
	.256 6,5	.374 9,5	12652	EXR 374-130	.50 12,7	.06 1,4	.25 6,4					
.161 4,1	.039 1,0	.138 3,5	12653	EXR 138-161	.25 6,4	.07 1,8	.32 8,0					
	.138 3,5	.236 6,0	12654	EXR 236-161	.38 9,6	.07 1,8	.32 8,0					
	.236 6,0	.354 9,0	12655	EXR 354-161	.50 12,7	.07 1,8	.32 8,0					
.193 4,9	.059 1,5	.177 4,5	12656	EXR 177-193	.31 8,0	.08 2,0	.38 9,6					
	.177 4,5	.295 7,5	12657	EXR 295-193	.44 11,2	.08 2,0	.38 9,6					
	.295 7,5	.413 10,5	12658	EXR 413-193	.57 14,4	.08 2,0	.38 9,6					
.224 5,7	.079 2,0	.197 5,0	12659	EXR 197-224	.38 9,6	.09 2,2	.47 12,0					
	.197 5,0	.315 8,0	12660	EXR 315-224	.50 12,7	.09 2,2	.47 12,0					
	.315 8,0	.453 11,5	12661	EXR 453-224	.63 15,9	.09 2,2	.47 12,0					

Standard color black.

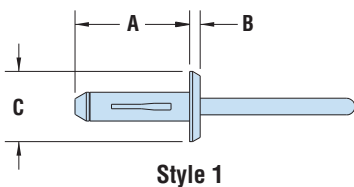

Style 1

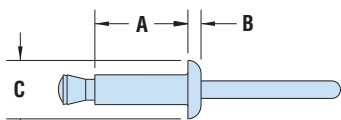

Style 2

	HSLG, HSLPB & EXR Body	EXR Pin	
Material	Nylon 6/6	Style 1 Acetal (POM)	Style 2 Polycarbonate
Flammability Rating	94V-2	94-HB	94V-2
Temperature Range	32°F (0°C) to 185° F (85°C) (All Series)		