

0.5mm Pitch Connectors with Ground Plate for 2mm to 3mm High-Speed Board-to-Board Connections

FX11 Series

Stacking height : 2mm

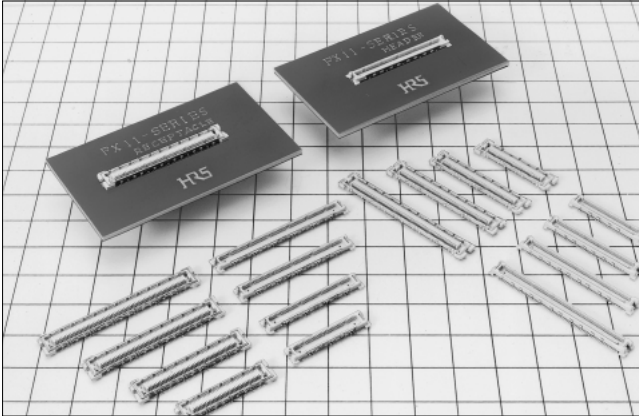

Stacking height : 2.5mm, 3mm

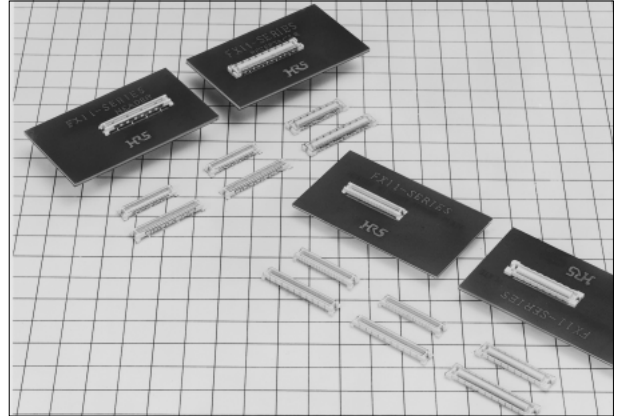

■ Features

1. Low Profile Design

The board-to-board mating height of 2mm, 2.5mm and 3mm suits smaller, thinner case designs. (Fig.2)

2. Improved Transmission Efficiency Between Boards

Transmission characteristics have been improved through a design that fixes ground plates to both sides of the header and receptacle.

3. 10 Signal:1 Ground Arrangement

Signal and ground are arranged in a ratio of 10:1 with the ground plate connected to the board Via SMT. The ground stability achieved serves to reduce noise. (Fig.1)

4. Metal Fittings for Added Strength

Metal fittings provide for greater adhesion to the board, which protects the connector against shearing forces. The unique connector design provides a connection between the fitting and the ground plate for a stronger ground.

5. Suited to High-Density Applications

The signal contact pitch of 0.5mm affords a compact connector, and reduces mounting space on the board.

6. Structure Prevents Solder Wicking

A solder gap has been designed into the contact SMT portion to prevent solder wicking. (Fig.3)

7. High Contact Reliability

Effective wipe length is 0.55mm (2mm height) and 1mm (2.5mm, 3mm height) for signal contacts.

8. Optional Ground Plate

An alternate style is also available without the ground plate. The space provided by the absence of the ground plate is filled with additional signal contacts.

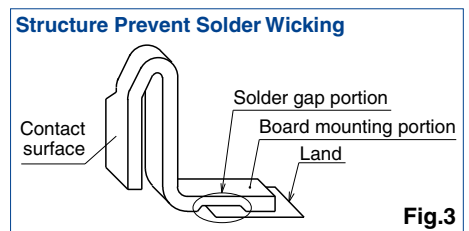
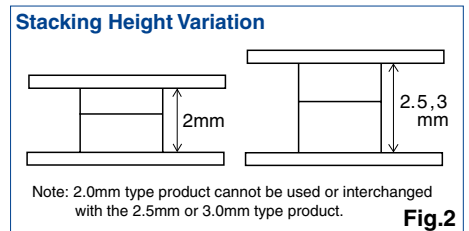
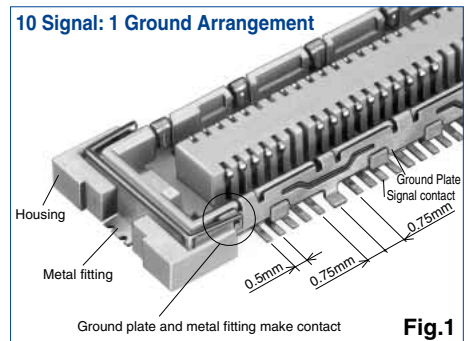

■ Signal Integrity Features

● Insertion-Loss-to-Crosstalk Ratio (ICR)

The insertion-loss-to-crosstalk ratio (ICR) with five differential FEXT aggressors meets the extrapolated IEEE802.3ap specification to 10+ Gbps.

● Differential Impedance

The differential impedance is 100 +/- 10Ω for FX11 at 50 ps rise time(20% to 80%).

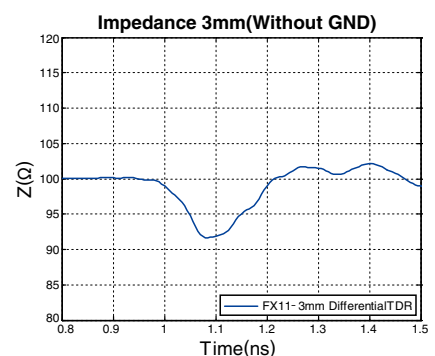
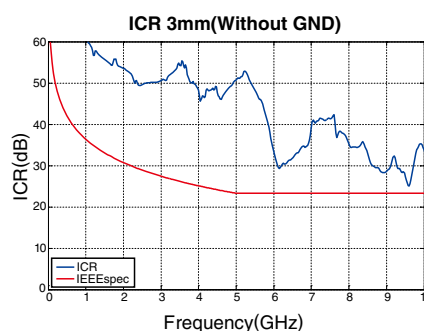

◆ Stacking height variation

● With ground plate

Receptacle	Header	FX11L#-*P / *-SV
FX11L#-*S / *-SV		2mm

Receptacle	Header	FX11#-*P / *-SV	FX11#-*P / *-SV0.5
FX11#-*S / *-SV		2.5mm	3mm

● Without ground plate

Receptacle	Header	FX11L#-*P-SV
FX11L#-*S-SV		2mm

Receptacle	Header	FX11#-*P-SV	FX11#-*P-SV0.5
FX11#-*S-SV		2.5mm	3mm

Note 1: The thickness of the solder paste is not included in the stacking height.

Note 2: 2mm type and 2.5mm, 3mm type, with ground plate type and without ground type are not mated with each other.

◆ Cross section of mating

● Stacking height : 2mm

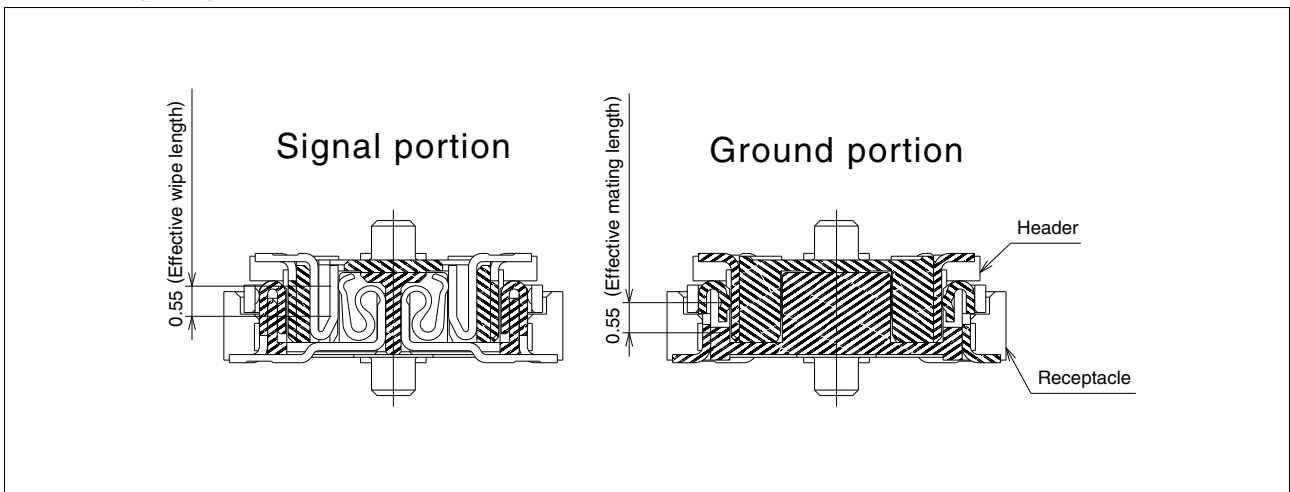

● Stacking height : 2.5mm, 3mm

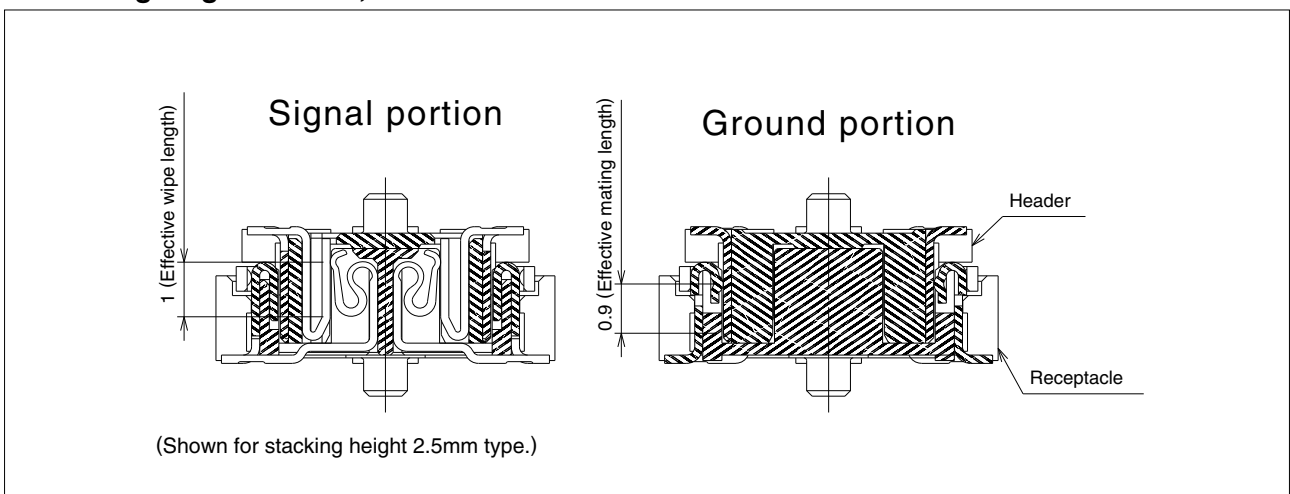

Stacking height : 2mm

Product Specifications

Rating	Rated current	0.3 A	Operating temperature range	-55 to 85°C	Storage temperature range	-10 to +60°C (Note 1)
	Rated voltage	50 V AC	Operating humidity range	Relative humidity 95% or less (No condensation)	Storage humidity range	40 to 70% (Note 1)

Item	Requirements	Conditions
1. Insulation resistance	100 MΩ or greater	Measured at 100 V DC
2. Withstanding voltage	No flashover or breakdown	150 V AC applied for one minute
3. Contact resistance	60 mΩ or less	Measured at 100 mA
4. Vibration resistance	No electrical discontinuity for 1μs or greater No damaged, cracked or loose parts	Frequency: 10 to 55 Hz, amplitude of 0.75 mm in 3 directions, 10 cycles each
5. Shock resistance	No electrical discontinuity for 1μs or longer No damaged, cracked or loose parts	Acceleration of 490 m/s ² , 11ms duration, sine half-wave waveform, for 3 cycles in the both directions of each of the 3 axes
6. Humidity resistance	Contact resistance of 70 mΩ or less, insulation resistance of 100 MΩ or greater, No damaged, cracked or loose parts	Temperature of 40°C, humidity of 90 to 95%, duration 96 h
7. Temperature cycle	Contact resistance of 70 mΩ or less, insulation resistance of 100 MΩ or greater, No damaged, cracked or loose parts	Temperature: -55°C → 15 to 35°C → 85°C → 15 to 35°C Time: 30 min. → 2 to 3 min. → 30 min. → 2 to 3 min. for 5 cycles
8. Mating cycles	Contact resistance of 70 mΩ or less No damaged, cracked or loose parts	50 times
9. Solder heat resistance	No melting of resin portion which affects performance	Reflow: At the recommended temperature profile Soldering iron temperature: 360°C for 5 seconds

Note 1: The term “storage” refers to the long-term-storage status of unused items before mounting on the PCB.
The operating temperature/humidity ranges apply to the unmated state after board mounting.

Materials

Part	Material	Finish		Remarks
Insulator	LCP	Beige		UL94V-0
Contacts	Copper alloy	Header	Engagement Area: Gold plating of 0.1μm	_____
	Phosphor bronze	Receptacle	Termination Area: Flash plating	
Ground plate	Phosphor bronze	Tin plating		_____
Metal fitting	Phosphor bronze	Tin plating		_____
Metal plate				_____

Product Number Structure

Type With Ground Plate **FX11L** ① ② - ③ ④ ⑤ - ⑥ **SV (**)**

Type Without Ground Plate **FX11L** ① ② - ③ ④ ⑤ - ⑥ **SV (**)**

① Series name : FX11L	④ Connector type P : Header S : Receptacle
② Form Symbol A : With guide post B : Without guide post	⑤ Contact form SV : Straight SMT
③ Number of contacts <u>Type without ground</u> Signal/Ground:60/6, 80/8, 100/10, 120/12 <u>Type with ground plate</u> Signal: 68, 92, 116, 140	⑥ Blank, (71): Tray packaging (Without pick-and-place tape) (21),(91): Embossed tape packaging (Without pick-and-place tape) (22),(92): Embossed tape packaging (With pick-and-place tape)

Header with Ground Plate

2mm stacking height

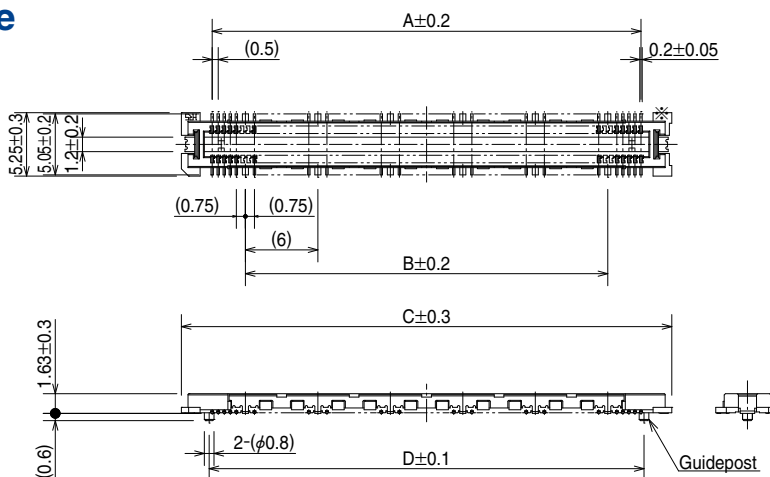

Unit : mm

Part No.	HRS No.	No. of Contacts		A	B	C	D	E	F	Remarks	RoHS
		Signal	Ground								
FX11LA-60P/6-SV(71)	573-0002-7 71	60	6	17.5	12	22.6	18	19.4	25.5	With guideposts	Yes
FX11LA-80P/8-SV(71)	573-0003-0 71	80	8	23.5	18	28.6	24	25.4	31.5		
FX11LA-100P/10-SV(71)	573-0004-2 71	100	10	29.5	24	34.6	30	31.4	37.5		
FX11LA-120P/12-SV(71)	573-0005-5 71	120	12	35.5	30	40.6	36	37.4	43.5		
FX11LB-60P/6-SV(71)	573-0012-0 71	60	6	17.5	12	22.6	—	19.4	25.5	Without guideposts	
FX11LB-80P/8-SV(71)	573-0013-3 71	80	8	23.5	18	28.6	—	25.4	31.5		
FX11LB-100P/10-SV(71)	573-0014-6 71	100	10	29.5	24	34.6	—	31.4	37.5		
FX11LB-120P/12-SV(71)	573-0015-9 71	120	12	35.5	30	40.6	—	37.4	43.5		

[Specifications number] – **, (**)
 (71) : Tray packaging
 (91) : Embossed tape packaging (Without pick-and-place tape)
 (92) : Embossed tape packaging (With pick-and-place tape)

Note 1 : There is no polarity in terms of board mounting for this product.
 Note 2 : The coplanarity of this product's SMT leads is 0.1 mm or less.
 Note 3 : Please order embossed tape packaged items by the reel. (1,000 pcs/reel)

Recommended Land Pattern Dimensions (Metal Mask Dimensions)

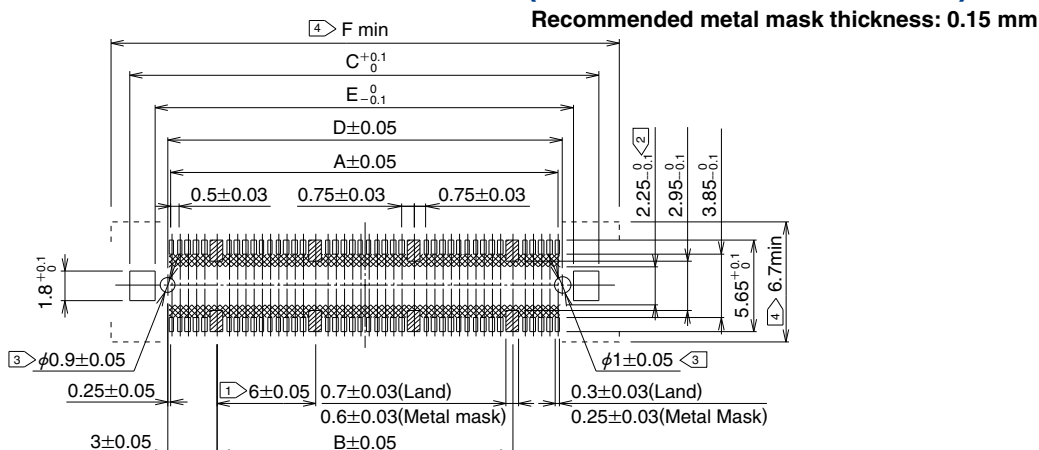

Note ① Cross-hatched portions, totaling n places, indicate the ground circuits.
 ② The cross-hatched area inside the SMT land may come into contact with the connector contacts and thus care should be taken that the pattern does not extend beyond the SMT land width.
 ③ Not required in products without guideposts.
 ④ Do not mount a part other than this product in the area of []. Doing so will prevent the engagement of this and the mating connector.

Receptacle with Ground Plate

2mm stacking height

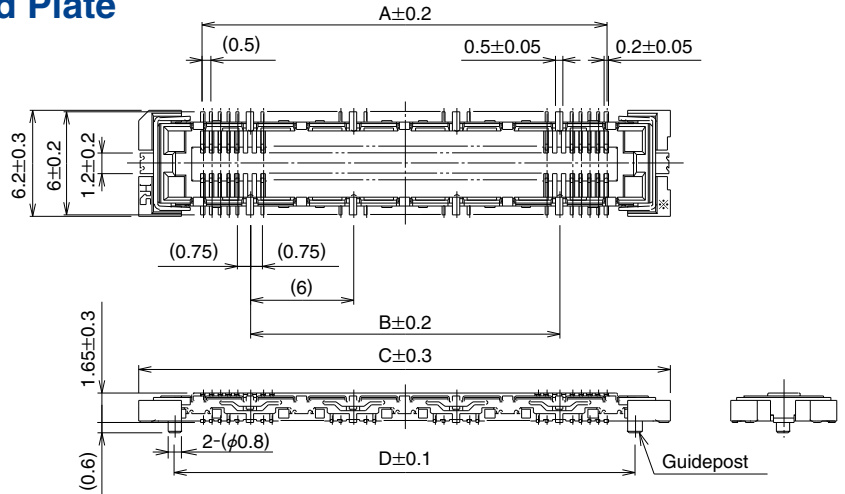

Unit : mm

Part No.	HRS No.	No. of Contacts		A	B	C	D	E	F	Remarks	RoHS
		Signal	Ground								
FX11LA-60S/6-SV(71)	573-0102-1 71	60	6	17.5	12	25	20.8	25.4	22.2	With guideposts	Yes
FX11LA-80S/8-SV(71)	573-0103-4 71	80	8	23.5	18	31	26.8	31.4	28.2		
FX11LA-100S/10-SV(71)	573-0104-7 71	100	10	29.5	24	37	32.8	37.4	34.2		
FX11LA-120S/12-SV(71)	573-0105-0 71	120	12	35.5	30	43	38.8	43.4	40.2		
FX11LB-60S/6-SV(71)	573-0112-5 71	60	6	17.5	12	25	—	25.4	22.2	Without guideposts	
FX11LB-80S/8-SV(71)	573-0113-8 71	80	8	23.5	18	31	—	31.4	28.2		
FX11LB-100S/10-SV(71)	573-0114-0 71	100	10	29.5	24	37	—	37.4	34.2		
FX11LB-120S/12-SV(71)	573-0115-3 71	120	12	35.5	30	43	—	43.4	40.2		

[Specifications number] – **, (**)
 (71) : Tray packaging (Without pick-and-place tape)
 (91) : Embossed tape packaging (Without pick-and-place tape)
 (92) : Embossed tape packaging (With pick-and-place tape)

Note 1 : There is no polarity in terms of board mounting for this product.
 Note 2 : The coplanarity of this product's SMT leads is 0.1 mm or less.
 Note 3 : Please order embossed tape packaged items by the reel. (1,000 pcs/reel)

Recommended Land Pattern Dimensions (Metal Mask Dimensions)

Recommended metal mask thickness: 0.15 mm

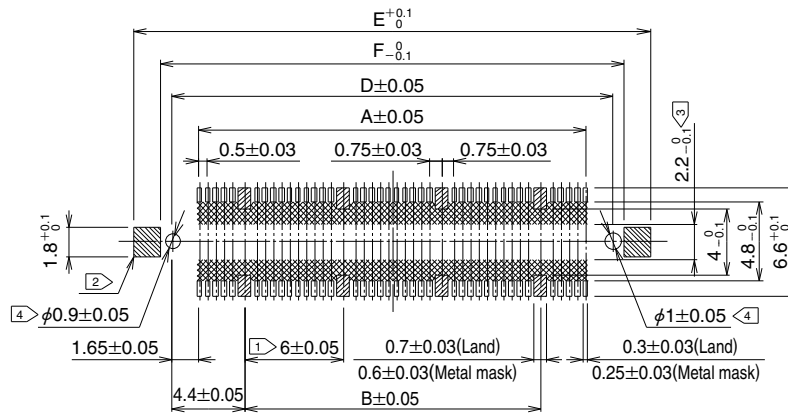

Note ① Cross-hatched portions, totaling n places, indicate the ground circuits.
 ② Cross-hatched portions, 2 places on both sides, indicate the metal fittings.
 ③ The cross-hatched area inside the SMT land may come into contact with the connector contacts and thus care should be taken that the pattern does not extend beyond the SMT land width.
 ④ Not required in products without guideposts.

Header without Ground Plate

2mm stacking height

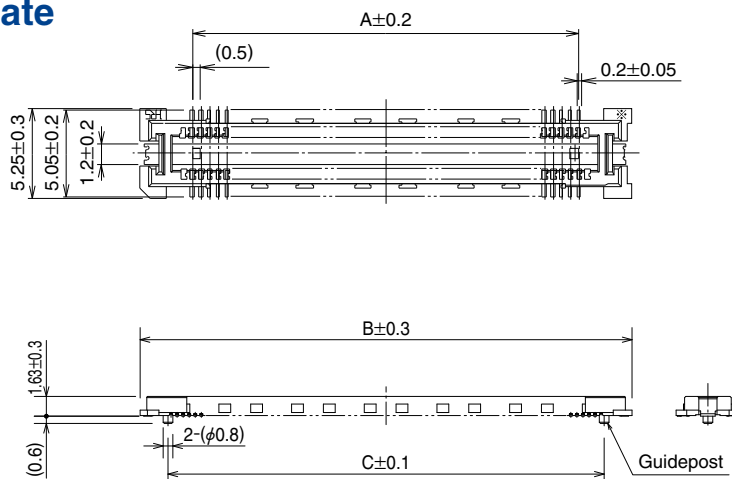

Unit : mm

Part No.	HRS No.	No. of Contacts	A	B	C	D	E	Remarks	RoHS
		Signal							
FX11LA-68P-SV(**)	573-0042-1 **	68	16.5	22.6	18	19.4	25.5	With guideposts	Yes
FX11LA-92P-SV(**)	573-0043-4 **	92	22.5	28.6	24	25.4	31.5		
FX11LA-116P-SV(**)	573-0044-7 **	116	28.5	34.6	30	31.4	37.5		
FX11LA-140P-SV(**)	573-0045-0 **	140	34.5	40.6	36	37.4	43.5		
FX11LB-68P-SV(**)	573-0052-5 **	68	16.5	22.6	—	19.4	25.5	Without guideposts	
FX11LB-92P-SV(**)	573-0053-8 **	92	22.5	28.6	—	25.4	31.5		
FX11LB-116P-SV(**)	573-0054-0 **	116	28.5	34.6	—	31.4	37.5		
FX11LB-140P-SV(**)	573-0055-3 **	140	34.5	40.6	—	37.4	43.5		

[Specifications number] – **, (**)
 Blank : Tray packaging (Without pick-and-place tape)
 (21) : Embossed tape packaging (Without pick-and-place tape)
 (22) : Embossed tape packaging (With pick-and-place tape)

Note 1 : There is no polarity in terms of board mounting for this product.
 Note 2 : The coplanarity of this product's SMT leads is 0.1 mm or less.
 Note 3 : Please order embossed tape packaged items by the reel. (1,000 pcs/reel)

Recommended Land Pattern Dimensions (Metal Mask Dimensions)

Recommended metal mask thickness: 0.15 mm

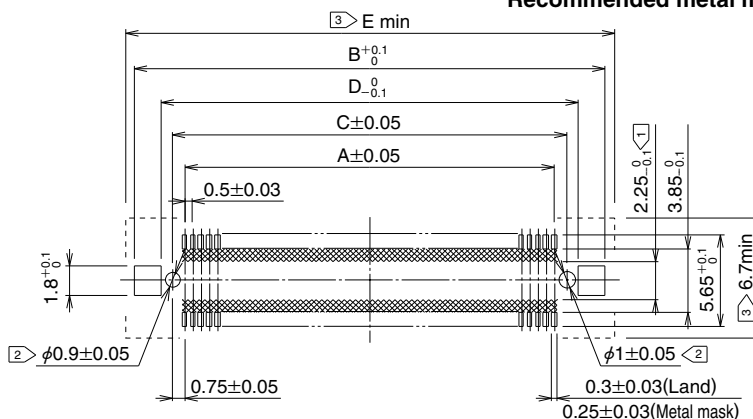

Note ① The cross-hatched area inside the SMT land may come into contact with the connector contacts and thus care should be taken that the pattern does not extend beyond the SMT land width.
 Note ② Not required in products without guideposts.
 Note ③ Do not mount a part other than this product in the area of . Doing so will prevent the engagement of this and the mating connector.

■ Receptacle without Ground Plate

● 2mm stacking height

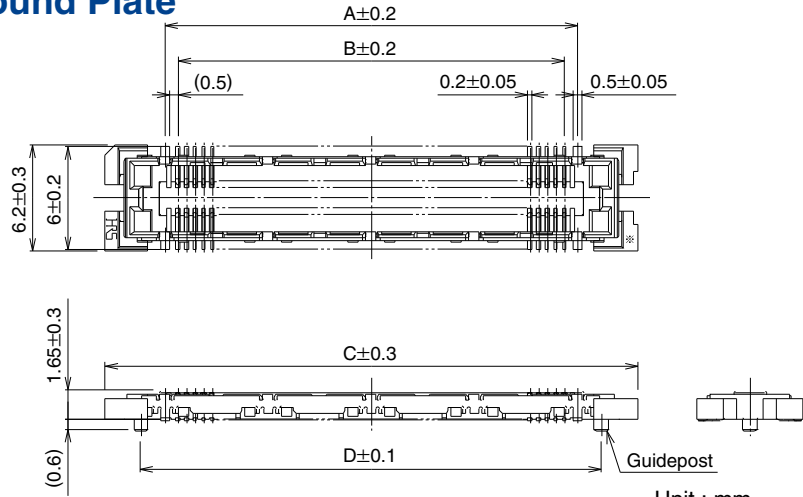

Part No.	HRS No.	No. of Contacts	A	B	C	D	Remarks	RoHS
		Signal						
FX11LA-68S-SV(**)	573-0142-6 **	68	18	16.5	25	20.8	With guideposts	Yes
FX11LA-92S-SV(**)	573-0143-9 **	92	24	22.5	31	26.8		
FX11LA-116S-SV(**)	573-0144-1 **	116	30	28.5	37	32.8		
FX11LA-140S-SV(**)	573-0145-4 **	140	36	34.5	43	38.8		
FX11LB-68S-SV(**)	573-0152-0 **	68	18	16.5	25	—	Without guideposts	
FX11LB-92S-SV(**)	573-0153-2 **	92	24	22.5	31	—		
FX11LB-116S-SV(**)	573-0154-5 **	116	30	28.5	37	—		
FX11LB-140S-SV(**)	573-0155-8 **	140	36	34.5	43	—		

[Specifications number] – **, (**)
 Blank : Tray packaging (Without pick-and-place tape)
 (21) : Embossed tape packaging (Without pick-and-place tape)
 (22) : Embossed tape packaging (With pick-and-place tape)

Note 1 : There is no polarity in terms of board mounting for this product.
 Note 2 : The coplanarity of this product's SMT leads is 0.1 mm or less.
 Note 3 : Please order embossed tape packaged items by the reel. (1,000 pcs/reel)

◆ Recommended Land Pattern Dimensions (Metal Mask Dimensions)

Recommended metal mask thickness: 0.15 mm

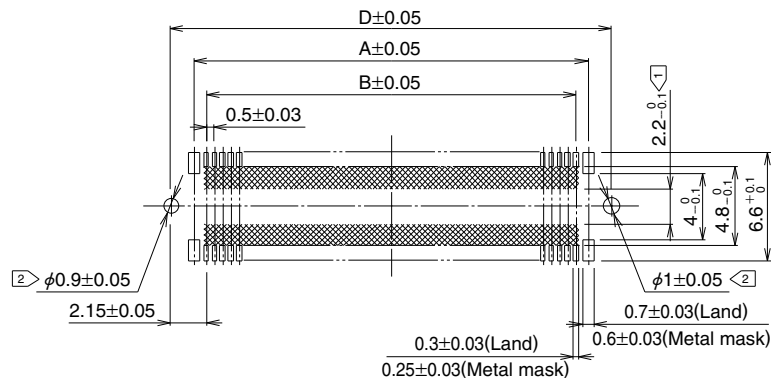

Note ① The cross-hatched area  inside the SMT land may come into contact with the connector contacts and thus care should be taken that the pattern does not extend beyond the SMT land width.
 Note ② Not required in products without guideposts.

Stacking height : 2.5mm, 3mm

Product Specifications

Rating	Rated current	0.3 A	Operating temperature range	-55 to 85°C	Storage temperature range	-10 to +60°C (Note 1)
	Rated voltage	50 V AC	Operating humidity range	Relative humidity 95% or less (No condensation)	Storage humidity range	40 to 70% (Note 1)

Item	Requirements	Conditions
1. Insulation resistance	100 MΩ or greater	Measured at 100 V DC
2. Withstanding voltage	No flashover or breakdown	150 V AC applied for one minute
3. Contact resistance	70 mΩ or less	Measured at 100 mA
4. Vibration resistance	No electrical discontinuity for 1μs or greater No damaged, cracked or loose parts	Frequency: 10 to 55 Hz, amplitude of 0.75 mm in 3 directions, 10 cycles each
5. Shock resistance	No electrical discontinuity for 1μs or longer No damaged, cracked or loose parts	Acceleration of 490 m/s ² , 11ms duration, sine half-wave waveform, for 3 cycles in the both directions of each of the 3 axes
6. Humidity resistance	Contact resistance of 80 mΩ or less, insulation resistance of 100 MΩ or greater, No damaged, cracked or loose parts	Temperature of 40°C, humidity of 90 to 95%, duration 96 h
7. Temperature cycle	Contact resistance of 80 mΩ or less, insulation resistance of 100 MΩ or greater, No damaged, cracked or loose parts	Temperature: -55°C → 15 to 35°C → 85°C → 15 to 35°C Time: 30 min. → 2 to 3 min. → 30 min. → 2 to 3 min. for 5 cycles
8. Mating cycles	Contact resistance of 80 mΩ or less No damaged, cracked or loose parts	50 times
9. Solder heat resistance	No melting of resin portion which affects performance	Reflow: At the recommended temperature profile Soldering iron temperature: 360°C for 5 seconds

Note 1: The term “storage” refers to the long-term-storage status of unused items before mounting on the PCB. The operating temperature/humidity ranges apply to the unmated state after board mounting.

Materials

Part	Material	Finish		Remarks
Insulator	LCP	Beige		UL94V-0
Contacts	Copper alloy	Header	Engagement Area: Gold plating of 0.1μm	_____
	Phosphor bronze	Receptacle	Termination Area: Flash plating	
Ground plate	Phosphor bronze	Tin plating		_____
Metal fitting	Phosphor bronze	Tin plating		_____
Metal plate				_____

Product Number Structure

Type With Ground Plate **FX11** **#** - ***** **P** / ***** - **SV** **0.5** **(**)**

①
②
③
④
⑤
⑥
⑦

Type Without Ground Plate **FX11** **#** - ***** **P** - **SV** **0.5** **(**)**

①
②
③
④
⑤
⑥
⑦

① Series name : FX11	④ Connector type P : Header S : Receptacle
② Form Symbol A : With guide post B : Without guide post	⑤ Contact form SV : Straight SMT
③ Number of contacts <u>Type without ground</u> Signal/Ground:60/6, 80/8, 100/10 <u>Type with ground plate</u> Signal: 80, 100	⑥ Product height Blank: Standard 0.5 : Standard + 0.5mm
	⑦ Blank, (71): Tray packaging (Without pick-and-place tape) (21),(91): Embossed tape packaging (Without pick-and-place tape) (22),(92): Embossed tape packaging (With pick-and-place tape)

Header with Ground Plate

2.5mm stacking height

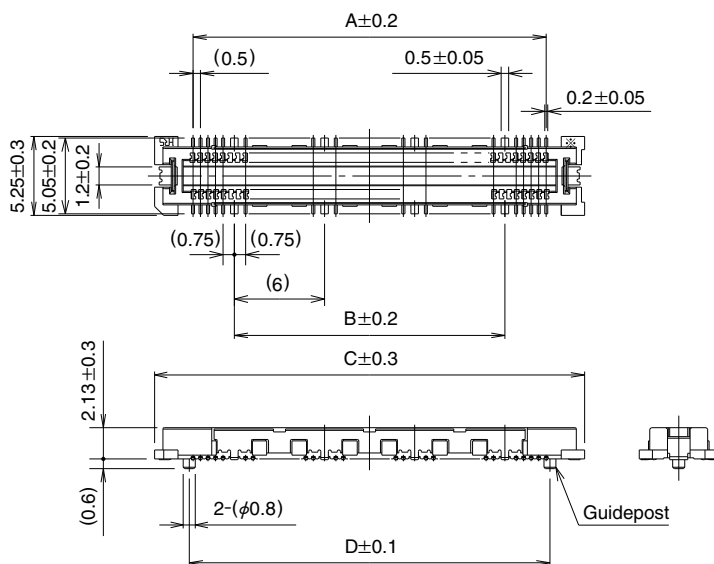

Unit : mm

Part No.	HRS No.	No. of Contacts		A	B	C	D	E	F	Remarks	RoHS
		Signal	Ground								
FX11A-60P/06-SV(71)	573-0502-0 71	60	6	17.5	12	22.6	18	19.4	25.5	With guideposts	Yes
FX11A-80P/08-SV(71)	573-0503-2 71	80	8	23.5	18	28.6	24	25.4	31.5		
FX11A-100P/10-SV(71)	573-0504-5 71	100	10	29.5	24	34.6	30	31.4	37.5		
FX11B-60P/06-SV(71)	573-0512-3 71	60	6	17.5	12	22.6	—	19.4	25.5	Without guideposts	
FX11B-80P/08-SV(71)	573-0513-6 71	80	8	23.5	18	28.6	—	25.4	31.5		
FX11B-100P/10-SV(71)	573-0514-9 71	100	10	29.5	24	34.6	—	31.4	37.5		

[Specifications number] – **, (**)

(71) : Tray packaging (Without pick-and-place tape)

(91) : Embossed tape packaging (Without pick-and-place tape)

(92) : Embossed tape packaging (With pick-and-place tape)

Note 1 : There is no polarity in terms of board mounting for this product.

Note 2 : The coplanarity of this product's SMT leads is 0.1 mm or less.

Note 3 : Please order embossed tape packaged items by the reel. (1,000 pcs/reel)

Recommended Land Pattern Dimensions (Metal Mask Dimensions)

Recommended metal mask thickness: 0.15 mm

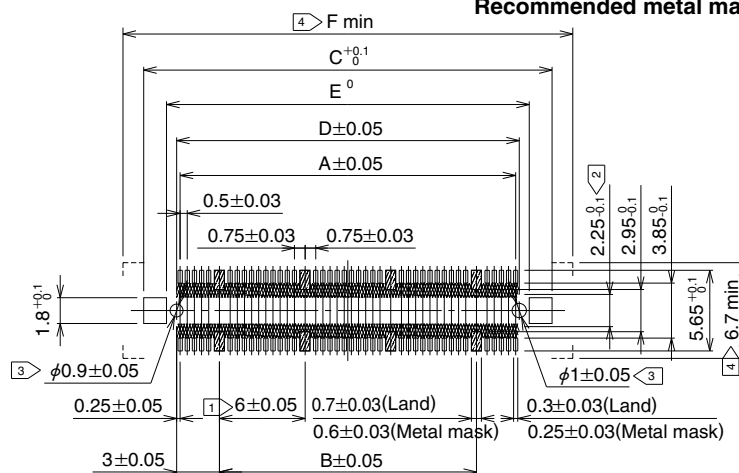

Note ① Cross-hatched portions, totaling n places, indicate the ground circuits.

② The cross-hatched area inside the SMT land may come into contact with the connector contacts and thus care should be taken that the pattern does not extend beyond the SMT land width.

③ Not required in products without guideposts.

④ Do not mount a part other than this product in the area of []. Doing so will prevent the engagement of this and the mating connector.

Header with Ground Plate

3mm stacking height

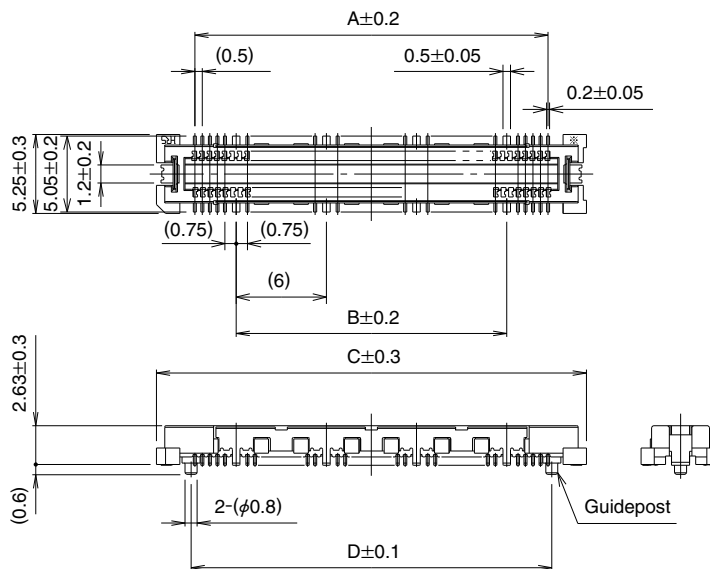

Unit : mm

Part No.	HRS No.	No. of Contacts		A	B	C	D	E	F	Remarks	RoHS
		Signal	Ground								
FX11A-60P/6-SV0.5(71)	573-0602-4 71	60	6	17.5	12	22.6	18	19.4	25.5	With guideposts	Yes
FX11A-80P/8-SV0.5(71)	573-0603-7 71	80	8	23.5	18	28.6	24	25.4	31.5		
FX11A-100P/10-SV0.5(71)	573-0604-0 71	100	10	29.5	24	34.6	30	31.4	37.5		
FX11B-60P/6-SV0.5(71)	573-0612-8 71	60	6	17.5	12	22.6	—	19.4	25.5	Without guideposts	
FX11B-80P/8-SV0.5(71)	573-0613-0 71	80	8	23.5	18	28.6	—	25.4	31.5		
FX11B-100P/10-SV0.5(71)	573-0614-3 71	100	10	29.5	24	34.6	—	31.4	37.5		

[Specifications number] – **, (**)
 (71) : Tray packaging (Without pick-and-place tape)
 (91) : Embossed tape packaging (Without pick-and-place tape)
 (92) : Embossed tape packaging (With pick-and-place tape)

- Note 1 : There is no polarity in terms of board mounting for this product.
- Note 2 : The coplanarity of this product's SMT leads is 0.1 mm or less.
- Note 3 : Please order embossed tape packaged items by the reel. (1,000 pcs/reel)

Recommended Land Pattern Dimensions (Metal Mask Dimensions)

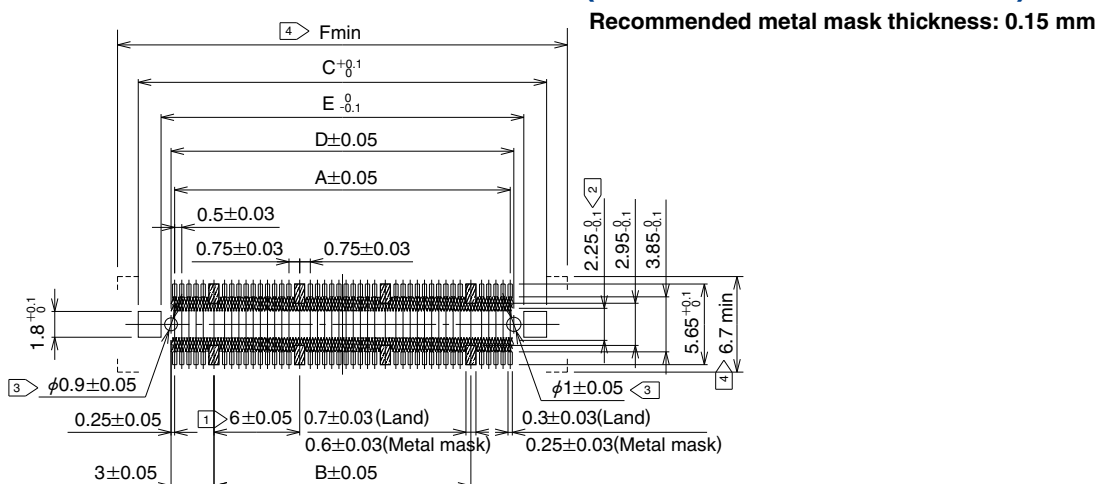

- Note ① Cross-hatched portions, totaling n places, indicate the ground circuits.
- Note ② The cross-hatched area inside the SMT land may come into contact with the connector contacts and thus care should be taken that the pattern does not extend beyond the SMT land width.
- Note ③ Not required in products without guideposts.
- Note ④ Do not mount a part other than this product in the area of []. Doing so will prevent the engagement of this and the mating connector.

■ Receptacle with Ground Plate

● 2.5mm, 3mm stacking height

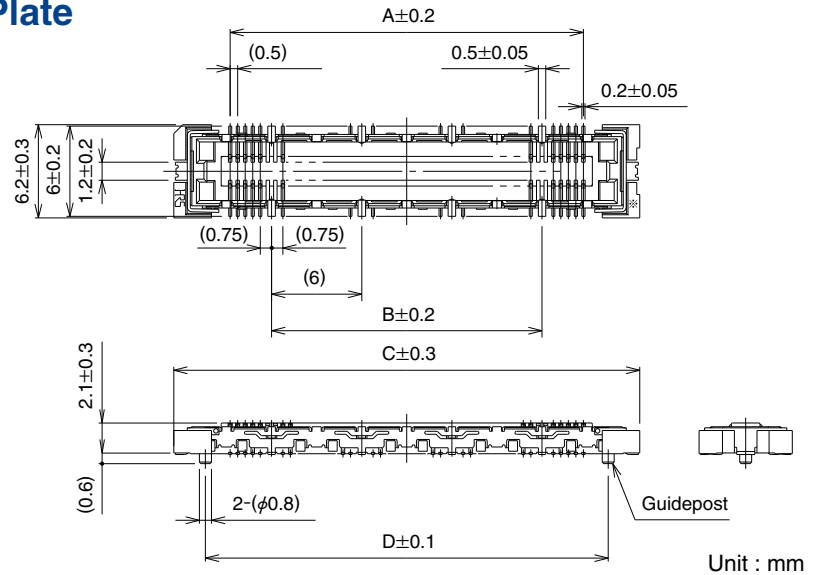
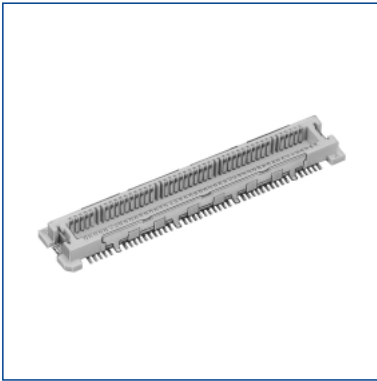

Part No.	HRS No.	No. of Contacts		A	B	C	D	E	F	Remarks	RoHS
		Signal	Ground								
FX11A-60S/6 SV(71)	573-0702-9 71	60	6	17.5	12	25	20.8	25.4	22.2	With guideposts	Yes
FX11A-80S/8 SV(71)	573-0703-1 71	80	8	23.5	18	31	26.8	31.4	28.2		
FX11A-100S/10 SV(71)	573-0704-4 71	100	10	29.5	24	37	32.8	37.4	34.2		
FX11B-60S/6 SV(71)	573-0712-2 71	60	6	17.5	12	25	—	25.4	22.2	Without guideposts	
FX11B-80S/8 SV(71)	573-0713-5 71	80	8	23.5	18	31	—	31.4	28.2		
FX11B-100S/10 SV(71)	573-0714-8 71	100	10	29.5	24	37	—	37.4	34.2		

[Specifications number] – **, (**)
 (71) : Tray packaging (Without pick-and-place tape)
 (91) : Embossed tape packaging (Without pick-and-place tape)
 (92) : Embossed tape packaging (With pick-and-place tape)

- Note 1 : There is no polarity in terms of board mounting for this product.
- Note 2 : The coplanarity of this product's SMT leads is 0.1 mm or less.
- Note 3 : Please order embossed tape packaged items by the reel. (1,000 pcs/reel)

◆ Recommended Land Pattern Dimensions (Metal Mask Dimensions)

Recommended metal mask thickness: 0.15 mm

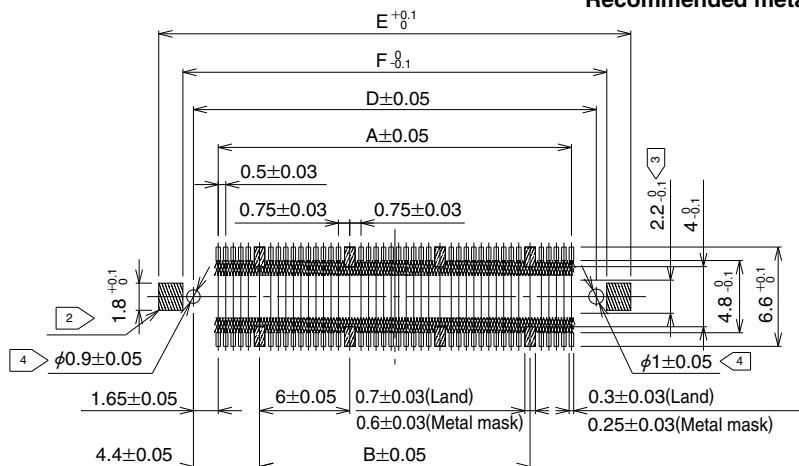

- Note ① Cross-hatched portions, totaling n places, indicate the ground circuits.
- Note ② Cross-hatched portions, totaling 2 places, indicate the metal fittings.
- Note ③ The cross-hatched area inside the SMT land may come into contact with the connector contacts and thus care should be taken that the pattern does not extend beyond the SMT land width.
- Note ④ Not required in products without guideposts.

Header without Ground Plate

● 2.5mm stacking height

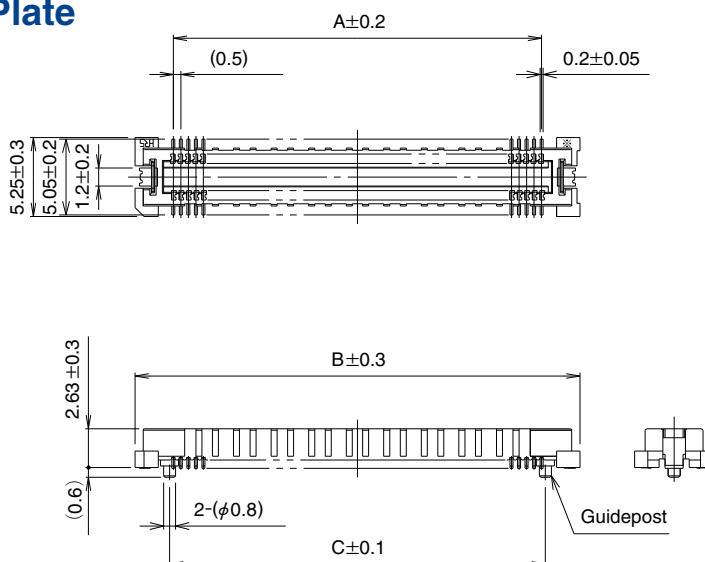

Unit : mm

Part No.	HRS No.	No. of Contacts	A	B	C	D	E	Remarks	RoHS
		Signal							
FX11A-80P-SV(**)	573-0548-0 **	80	19.5	24.6	20	21.4	27.5	With guideposts	Yes
FX11A-100P-SV(**)	573-0543-7 **	100	24.5	29.6	25	26.4	32.5		
FX11B-80P-SV(**)	573-0558-4 **	80	19.5	24.6	—	21.4	27.5	Without guideposts	
FX11B-100P-SV(**)	573-0553-0 **	100	24.5	29.6	—	26.4	32.5		

[Specifications number] – **, (**)

Blank : Tray packaging (Without pick-and-place tape)

(21) : Embossed tape packaging (Without pick-and-place tape)

(22) : Embossed tape packaging (With pick-and-place tape)

Note 1 : There is no polarity in terms of board mounting for this product.

Note 2 : The coplanarity of this product's SMT leads is 0.1 mm or less.

Note 3 : Please order embossed tape packaged items by the reel. (1,000 pcs/reel)

◆ Recommended Land Pattern Dimensions (Metal Mask Dimensions)

Recommended metal mask thickness: 0.15 mm

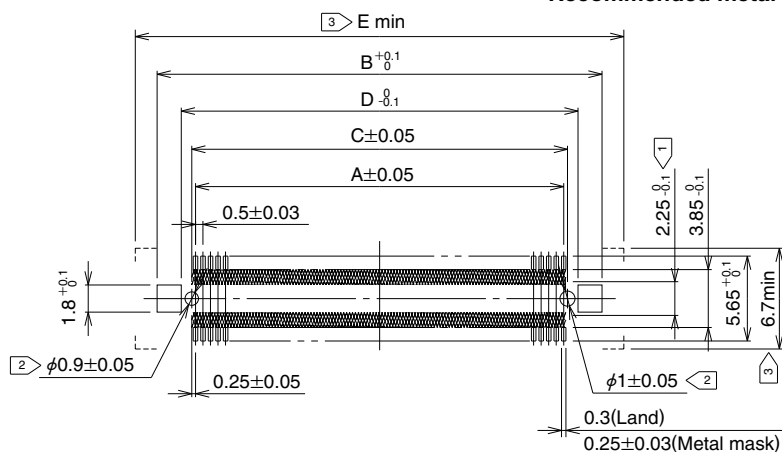

Note ① The cross-hatched area  inside the SMT land may come into contact with the connector contacts and thus care should be taken that the pattern does not extend beyond the SMT land width.

② Not required in products without guideposts.

③ Do not mount a part other than this product in the area of . Doing so will prevent the engagement of this and the mating connector.

Header without Ground Plate

3mm stacking height

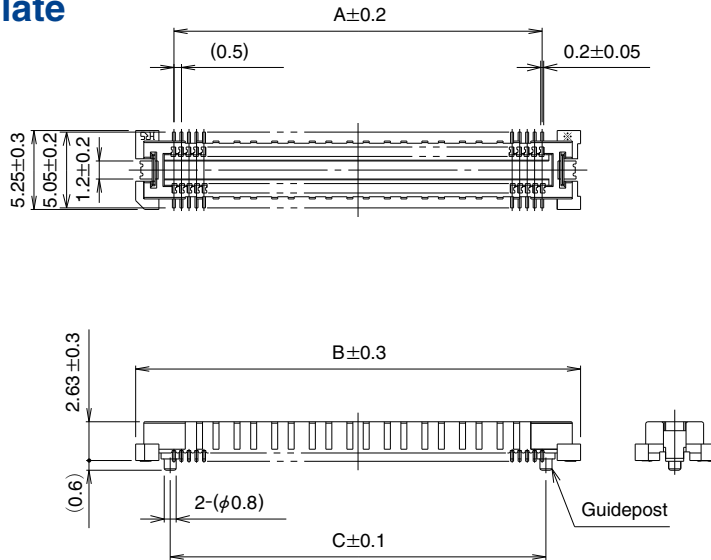
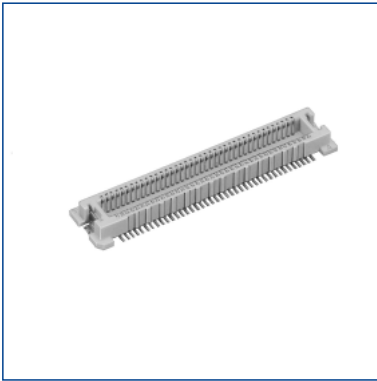

Unit : mm

Part No.	HRS No.	No. of Contacts	A	B	C	D	E	Remarks	RoHS
		Signal							
FX11A-80P-SV0.5(**)	573-0648-5 **	80	19.5	24.6	20	21.4	27.5	With guideposts	Yes
FX11A-100P-SV0.5(**)	573-0643-1 **	100	24.5	29.6	25	26.4	32.5		
FX11B-80P-SV0.5(**)	573-0658-9 **	80	19.5	24.6	—	21.4	27.5	Without guideposts	
FX11B-100P-SV0.5(**)	573-0653-5 **	100	24.5	29.6	—	26.4	32.5		

[Specifications number] – **, (**)

Blank : Tray packaging (Without pick-and-place tape)

(21) : Embossed tape packaging (Without pick-and-place tape)

(22) : Embossed tape packaging (With pick-and-place tape)

Note 1 : There is no polarity in terms of board mounting for this product.

Note 2 : The coplanarity of this product's SMT leads is 0.1 mm or less.

Note 3 : Please order embossed tape packaged items by the reel. (1,000 pcs/reel)

Recommended Land Pattern Dimensions (Metal Mask Dimensions)

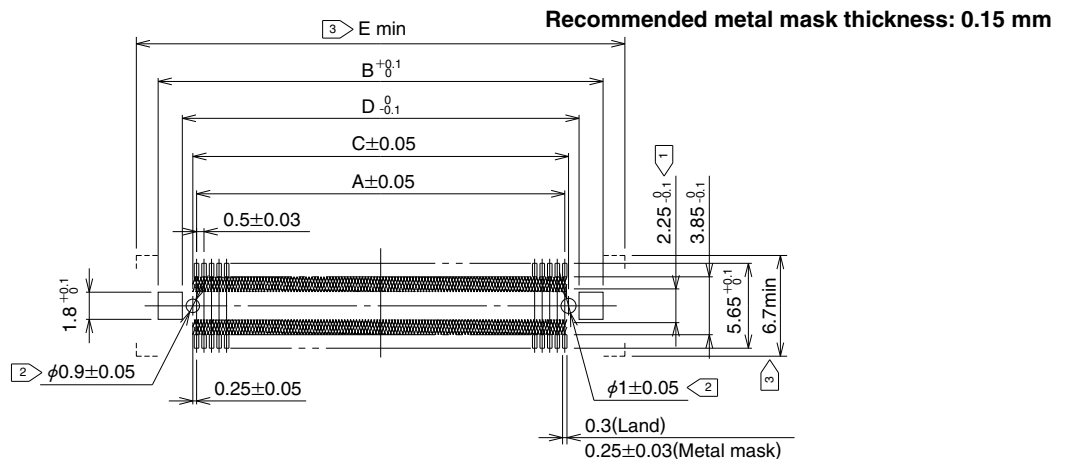

Note ① The cross-hatched area inside the SMT land may come into contact with the connector contacts and thus care should be taken that the pattern does not extend beyond the SMT land width.

② Not required in products without guideposts.

③ Do not mount a part other than this product in the area of . Doing so will prevent the engagement of this and the mating connector.

■ Receptacle without Ground Plate

● 2.5mm, 3mm stacking height

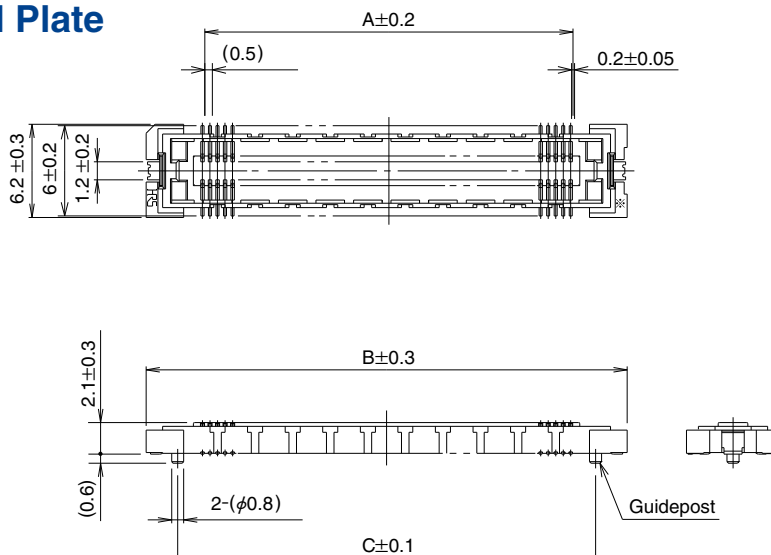

Unit : mm

Part No.	HRS No.	No. of Contacts	A	B	C	D	E	Remarks	RoHS
		Signal							
FX11A-80S-SV(**)	573-0748-0 **	80	19.5	27	22.8	27.4	24.2	With guideposts	Yes
FX11A-100S-SV(**)	573-0743-6 **	100	24.5	32	27.8	32.4	29.2		
FX11B-80S-SV(**)	573-0758-3 **	80	19.5	27	—	27.4	24.2	Without guideposts	
FX11B-100S-SV(**)	573-0753-0 **	100	24.5	32	—	32.4	29.2		

[Specifications number] – **, (**)

Blank : Tray packaging (Without pick-and-place tape)

(21) : Embossed tape packaging (Without pick-and-place tape)

(22) : Embossed tape packaging (With pick-and-place tape)

Note 1 : There is no polarity in terms of board mounting for this product.

Note 2 : The coplanarity of this product's SMT leads is 0.1 mm or less.

Note 3 : Please order embossed tape packaged items by the reel. (1,000 pcs/reel)

◆ Recommended Land Pattern Dimensions (Metal Mask Dimensions)

Recommended metal mask thickness: 0.15 mm

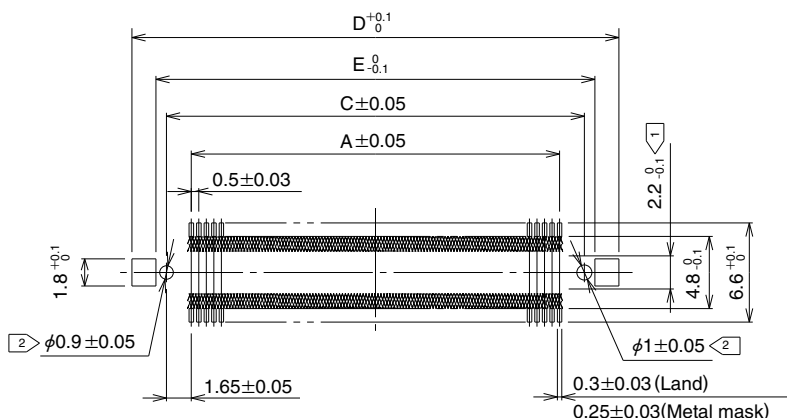

Note ① The cross-hatched area inside the SMT land may come into contact with the connector contacts and thus care should be taken that the pattern does not extend beyond the SMT land width.

Note ② Not required in products without guideposts.

◆ Embossed Carrier Tape Dimensions

Unit : mm

● Header

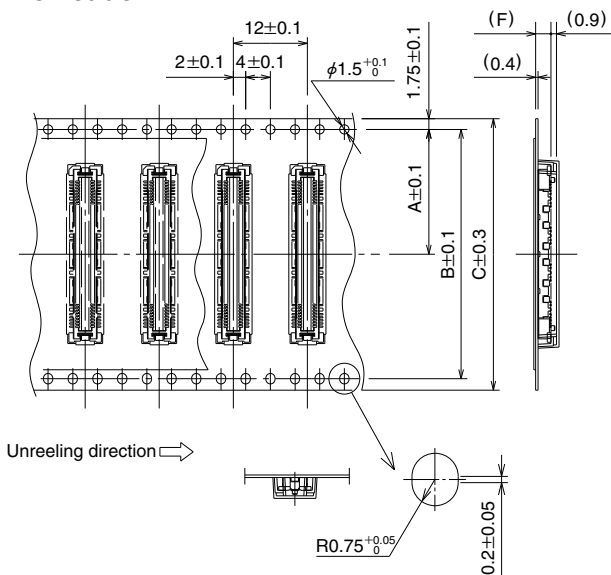

Insertion Connector	A	B	C	D	E	F
FX11L #-60P/6-SV	20.2	40.4	44	45.5	50.5	1.98
FX11L #-80P/8-SV						
FX11L #-100P/10-SV	26.2	52.4	56	59	64	
FX11L #-120P/12-SV						
FX11L #-68P-SV	20.2	40.4	44	45.5	50.5	
FX11L #-92P-SV						
FX11L #-116P-SV	26.2	52.4	56	59	64	
FX11L #-140P-SV						
FX11 #-60P/6-SV	20.2	40.4	44	45.5	50.5	2.48
FX11 #-80P/8-SV						
FX11 #-100P/10-SV	26.2	52.4	56	59	64	
FX11 #-80P-SV						
FX11 #-100P-SV	20.2	40.4	44	45.5	50.5	
FX11 #-60P/6-SV0.5						
FX11 #-80P/8-SV0.5	26.2	52.4	56	59	64	2.98
FX11 #-100P/10-SV0.5						
FX11 #-80P-SV0.5	20.2	40.4	44	45.5	50.5	
FX11 #-100P-SV0.5						

Note 1: There is no polarity in terms of embossed tape packaging for this product.

Note 2: Left figure is representative of products with ground plates.

● Receptacle

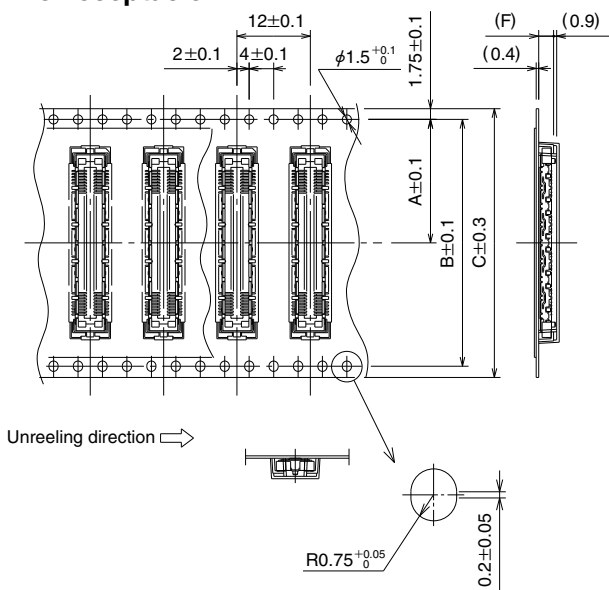

Unit : mm

Insertion Connector	A	B	C	D	E	F
FX11L #-60S/6-SV	20.2	40.4	44	45.5	50.5	2
FX11L #-80S/8-SV						
FX11L #-100S/10-SV	26.2	52.4	56	59	64	
FX11L #-120S/12-SV						
FX11L #-68S-SV	20.2	40.4	44	45.5	50.5	
FX11L #-92S-SV						
FX11L #-116S-SV	26.2	52.4	56	59	64	
FX11L #-140S-SV						
FX11 #-60S/6-SV	20.2	40.4	44	45.5	50.5	2.45
FX11 #-80S/8-SV						
FX11 #-100S/10-SV	26.2	52.4	56	59	64	
FX11 #-80S-SV						
FX11 #-100S-SV	20.2	40.4	44	45.5	50.5	
FX11 #-100S-SV						

Note 1: There is no polarity in terms of embossed tape packaging for this product.

Note 2: Left figure is representative of products with ground plates.

● Reel Dimensions

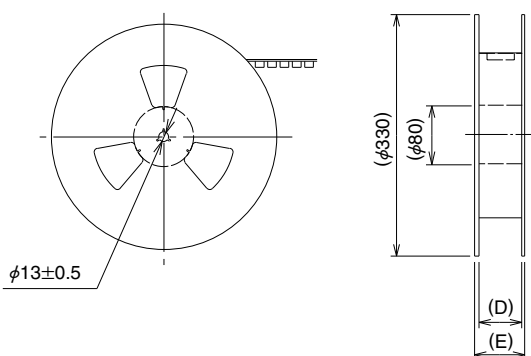

Recommended Temperature Profile

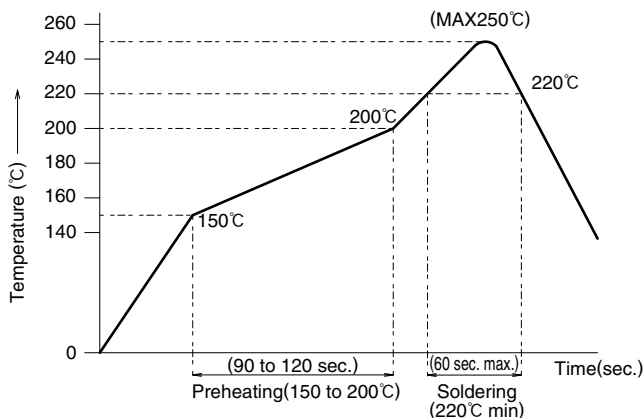

Note : The temperature profile indicates the maximum temperature of the connector surfaces at the highest point from the PCB mounting surface.

HRS test conditions

Test board Glass epoxy 60mm×35mm×1.6mm thick
 Solder method : Reflow
 Solder composition : Paste, 96.5%Sn/ 3%Ag/ 0.5%Cu
 Metal mask : 0.15mm thick
 Reflow cycles : 2 cycles

The temperature profile is based on the above conditions. In individual applications the actual temperature may vary, depending on solder paste type, volume/thickness and board size/thickness. Consult your solder paste and equipment manufacturer for specific recommendations.

Washing Conditions

Organic Solvent Washing

Solvent	Room temperature washing	Heated washing
IPA (Isopropyl alcohol)	Yes	Yes

Water Type Washing

When using water type cleaning agents (e.g., terpene, and alkali saponifiers), select the cleaning agent based on the documentation issued by the various manufacturers of cleaning agents which describes the effects on metals and resins. Be careful that parts are not left with moisture remaining on them.

Washing Precautions

Residual flux or cleaning agent on the contacts when washing with organic solvents or water type cleaners can give rise to the deterioration of electrical performance. In this regard it is important to check whether a thorough washing has been performed.

Connector Handling Precautions

1. Allowable Creepage Dimensions at Time of Mating

[Stacking height : 2mm]

The effective coupling length of this product is 0.55 mm for the signal portion and the ground portion. The creepage of the header and receptacle at the time of mating should be within 0.18 mm of the completely coupled condition.

[Stacking height : 2.5mm, 3mm]

The effective coupling length of this product is 1 mm for the signal portion and 0.9mm for the ground portion. The creepage of the header and receptacle at the time of mating should be within 0.4 mm of the completely coupled condition.

2. Compatibility

2mm type and 2.5mm, 3mm type, with ground plate type and without ground type are not mated with each other.

3. Retension of Boards

Avoid the support of boards by connectors alone and adopt a board locking measure that does not rely on the connectors.

4. Solder Repair

Flux may rise as far as the contact portion of the connector depending on the flux coating and other factors at the time of repair. This will cause poor contact reliability; therefore, before use, the aforementioned washing conditions should be taken into consideration prior to connector washing.

5. Miscellaneous

- Note that excessive twisting while inserting or withdrawing connectors will cause damage.
- The shade of the molded items may vary somewhat depending on the manufacturing lot; however, this does not affect performance.

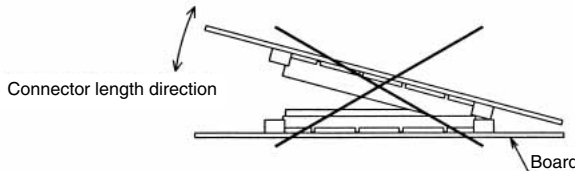
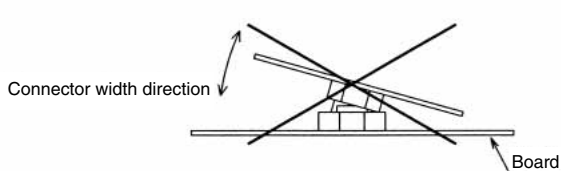

HIROSE ELECTRIC CO.,LTD.

2-6-3, Nakagawa Chuoh, Tsuzuki-Ku, Yokohama-Shi 224-8540, JAPAN
 TEL: +81-45-620-3526 Fax: +81-45-591-3726
<http://www.hirose.com>
<http://www.hirose-connectors.com>