

0.3 or 0.4 mm pitch, 3 mm above the board, Flip-Lock actuator, Flexible Printed Circuit ZIF connectors

FH30 Series

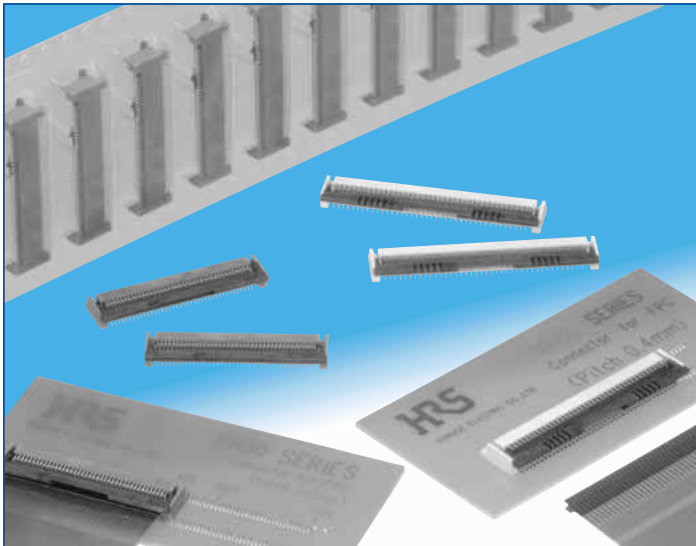

Strong actuator construction

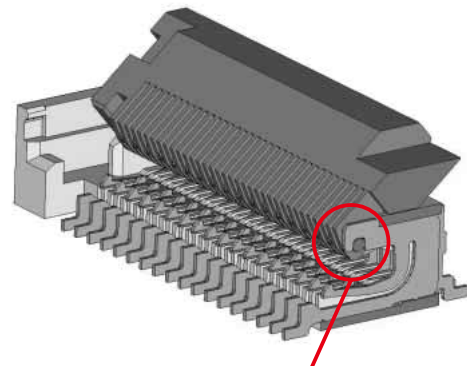

Enclosed shaft of the actuator prevents it from dislocation

Simple FPC insertion

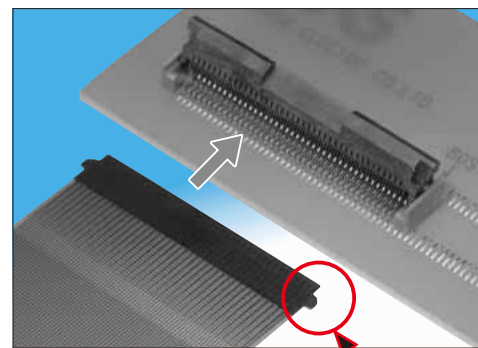

FPC positioning tab

Lock

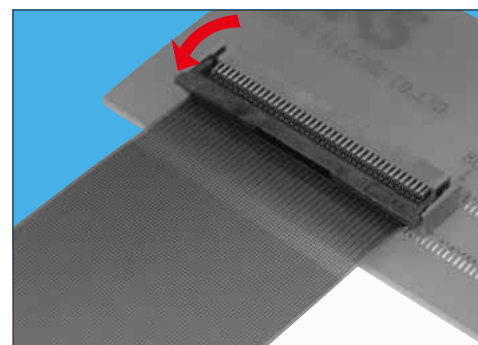

■ Features

1. Strong actuator retention

Actuator will not be dislodged when operating under harsh conditions.

2. Rotating Flip-Lock actuator

Rotating actuator permits easy insertion and retention of the FPC.

Tactile sensation confirms complete FPC insertion and reliable mechanical and electrical connection.

3. FPC position hold

Tabs on each side of the FPC assure correct placement and hold in the connector prior to closing of the actuator.

4. Accepts standard FPC thickness

0.3mm thick standard Flexible Printed Circuit (FPC) can be used.

5. Easy solderability on the PC board

The soldering leads are on 0.6 mm or 0.8 mm pitch, exiting on the front and back of the connector.

6. Board placement with automatic equipment

Flat upper surface and tape and reel packaging facilitate vacuum pick-up and placement. Standard reel packaging contains 1000 connectors.

7. Conductive traces on the PCB can run under the connector

No exposed contacts on the bottom of the connector.

8. Halogen-free*

* As defined by IEC61249-2-21

Br-900ppm maximum, Cl-900ppm maximum,
Cl + Br combined-1,500ppm maximum

Product Specifications

Ratings		0.3 mm pitch	0.4 mm pitch	Operating temperature range -40 to +85°C (Note 2)	Storage temperature range -10 to +50°C (Note 3)
	Current rating(Note 1)	0.15 A	0.3 A	Operating humidity range Relative humidity 90% max.	Storage humidity range Relative humidity 90% max.
	Voltage rating	30 Vrms AC	50 Vrms AC	(No condensation)	(No condensation)

Recommended FPC	Thickness: 0.3±0.05, Gold plated contact pads
-----------------	---

Item	Specification	Conditions
1. Insulation resistance	500 MΩ min.	100 V DC
2. Withstanding voltage	No flashover or insulation breakdown	0.3 mm pitch: 90 Vrms AC / 1 minute 0.4mm pitch: 150 Vrms AC / 1 minute
3. Contact resistance	150 mΩ max. * Including FPC conductor resistance	1 mA AC
4. Durability	Contact resistance: 150 mΩ max. No damage, cracks, or parts dislocation	20 cycles
5. Vibration	No electrical discontinuity of 1μs or longer Contact resistance: 150 mΩ max. No damage, cracks, or parts dislocation	Frequency: 10 to 55 Hz, single amplitude of 0.75 mm 10 cycles in each of the 3 directions
6. Shock	No electrical discontinuity of 1μs or longer Contact resistance: 150 mΩ max. No damage, cracks, or parts dislocation	Acceleration of 981m/s ² , 6 ms duration, sine half-wave, 3 cycles in each of the 3 axis
7. Humidity (Steady state)	Contact resistance: 150 mΩ max. Insulation resistance: 50MΩ min. No damage, cracks, or parts dislocation	96 hours at 40°C and humidity of 90 to 95%
8. Temperature cycle	Contact resistance: 150 mΩ max. Insulation resistance: 50MΩ min. No damage, cracks, or parts dislocation	Temperature: -40°C → +15°C to 35°C → +85°C → +15°C to 35°C Time: -30 → 2 to 3 → +30 → +2 to 3 5 cycles
9. Resistance to soldering heat	No deformation of components affecting performance.	Reflow: At the recommended temperature profile Manual soldering: 350°C for 5 seconds

Note1: When passing the current through all of the contacts, use 70% of the rated current.

Note2: Includes temperature rise caused by current flow.

Note3: The term "storage" refers to products stored for a long period prior to mounting and use.

The operating temperature and humidity range covers the non-conducting condition of connectors after installation on a board.

Materials

Part	Material	Finish	Remarks
Insulator	LCP	FH30 series Color:Gray	UL94V-0
		FH30M series Color:Beige	
Contacts	Phosphor bronze	Gold plated	———

Ordering information

FH 30 M - 80S - 0.3 SHW (05)

① ② ③ ④ ⑤ ⑥ ⑦

① Series name	: FH
② Series No.	: 30
③ Blank	: 0.3mm pitch M : 0.4 mm pitch
④ Number of contacts	: FH30 series 60, 80, 90 FH30M series 80, 96
⑤ Contact pitch	: 0.3 mm, 0.4 mm
⑥ Contact type	: SHW(SMT horizontal staggered mounting)
⑦ Plating specifications	: (05)...Gold plated (98)...Gold plated, 500 pieces/reel

■ Dimensions

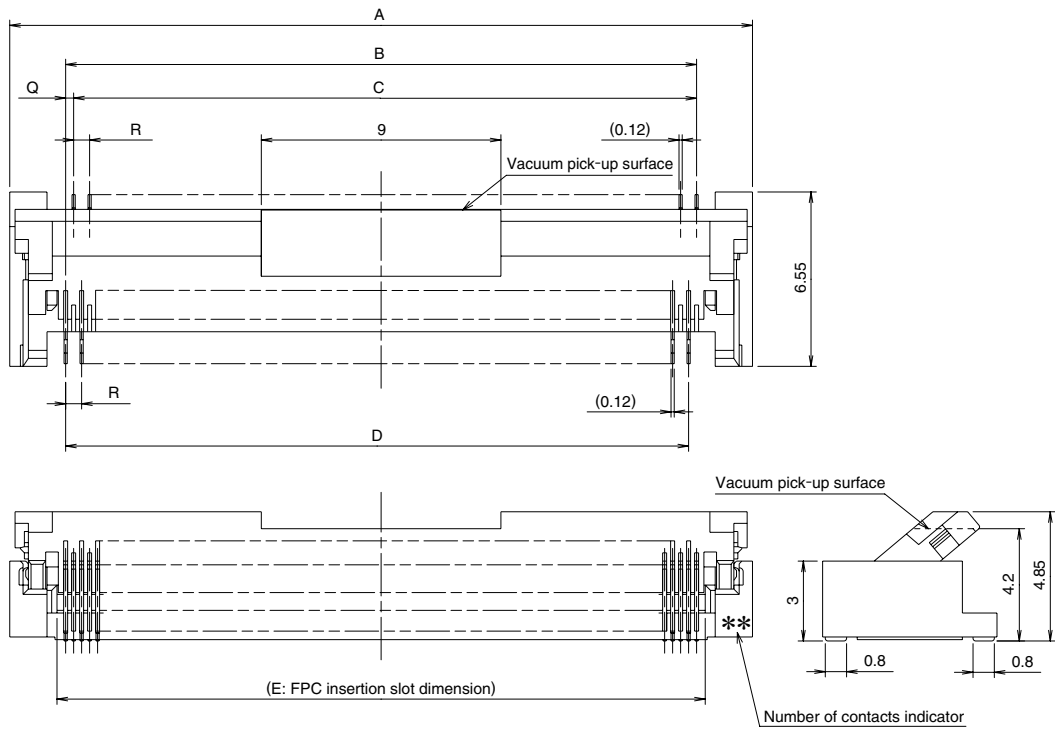

- Notes 1: The coplanarity of each terminal lead is within 0.1.
 2: Packaged on tape and reel only. Check packaging specification.
 3: Slight variations in color of the plastic compounds do not affect form, fit or function of the connector.
 4: After reflow, the terminal plating may change color, however this does not represent a quality issue.

All dimensions: mm

Part Number	CL No.	Number of Contacts	FPC contact pitch	A	B	C	D	E	Q	R
FH30-60S-0.3SHW(05)	580-0105-8-05	60	0.3	21.9	17.7	17.4	17.4	18.35	0.3	0.6
FH30-80S-0.3SHW(05)	580-0100-4-05	80	0.3	27.9	23.7	23.4	23.4	24.35	0.3	0.6
FH30-90S-0.3SHW(05)	580-0106-0-05	90	0.3	30.9	26.7	26.4	26.4	27.35	0.3	0.6
FH30M-80S-0.4SHW(05)	580-0102-0-05	80	0.4	35.8	31.6	31.2	31.2	32.25	0.4	0.8
FH30M-96S-0.4SHW(05)	580-0103-2-05	96	0.4	42.2	38	37.6	37.6	38.65	0.4	0.8

Tape and reel packaging (1,000 pieces/reel, 500 pieces/reel).

Order by number of reels.

Recommended PCB mounting pattern and metal mask dimensions

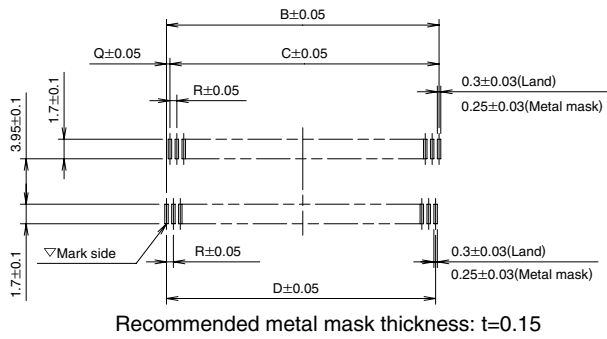

Recommended FPC Dimensions

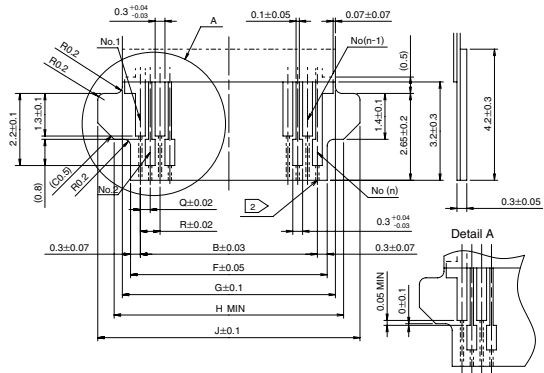

Note ①: Conductor width shall be 0.1 ± 0.05 if FPC has plating bars.

All dimensions: mm

Part Number	CL No.	Number of Contacts	FPC contact pitch	B	C	D	F	G	H	J	Q	R
FH30-60S-0.3SHW(05)	580-0105-8-05	60	0.3	17.7	17.4	17.4	18.3	18.8	19.3	20.3	0.3	0.6
FH30-80S-0.3SHW(05)	580-0100-4-05	80	0.3	23.7	23.4	23.4	24.3	24.8	25.3	26.3	0.3	0.6
FH30-90S-0.3SHW(05)	580-0106-0-05	90	0.3	26.7	26.4	26.4	27.3	27.8	28.3	29.3	0.3	0.6
FH30M-80S-0.4SHW(05)	580-0102-0-05	80	0.4	31.6	31.2	31.2	32.2	32.7	33.2	34.2	0.4	0.8
FH30M-96S-0.4SHW(05)	580-0103-2-05	96	0.4	38	37.6	37.6	38.6	39.1	39.6	40.6	0.4	0.8

FH30 Series Recommended FPC Construction

1. Using Single-sided FPC

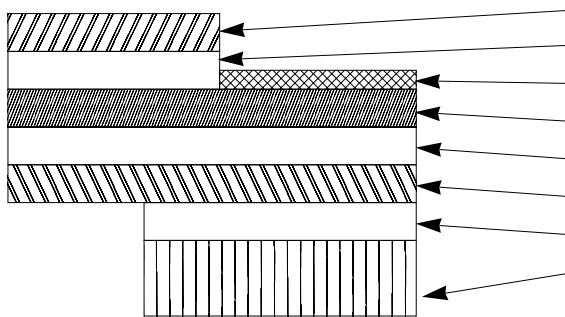

Material Name	Material	Material Thickness (μm)
Covering film layer	Polyimide 1 mil thick	(25)
Cover adhesive		(25)
Surface treatment	$0.2\mu\text{m}$ thick gold plated over 1 to $5\mu\text{m}$ thick nickel underplating	3
Copper foil	Cu 1oz	35
Base adhesive	Thermosetting adhesive	25
Base film	Polyimide 1 mil thick	25
Reinforcement material adhesive	Thermosetting adhesive	30
Stiffener	Polyimide 7 mil thick	175
Total		293

2. Using Double-sided FPC

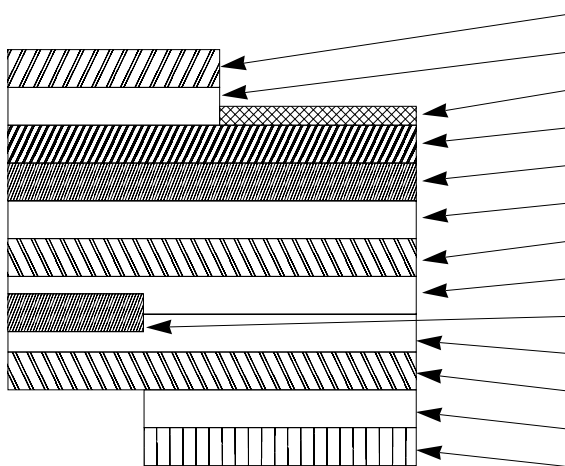

Material Name	Material	Material Thickness (μm)
Covering layer film	Polyimide 1 mil thick	(25)
Cover adhesive		(25)
Surface treatment	$0.2\mu\text{m}$ thick gold plated over 1 to $5\mu\text{m}$ thick nickel underplating	3
Through-hole copper	Cu	15
Copper foil	Cu 1/2oz	18
Base adhesive	Thermosetting adhesive	18
Base film	Polyimide 1 mil thick	25
Base adhesive	Thermosetting adhesive	18
Copper foil	Cu 1/2oz	(18)
Cover adhesive	Thermosetting adhesive	25
Covering film layer	Polyimide 1 mil thick	25
Reinforcement material adhesive	Thermosetting adhesive	50
Stiffener	Polyimide 4 mil thick	100
Total		297

* To prevent release of the FPC due to its bending, use of the double-sided FPC with copper foil on the back side is NOT RECOMMENDED.

3. Precautions

1. This specification is a recommendation for the construction of the FH30 Series FPC ($t=0.3 \pm 0.05$).
2. For details about the construction, please contact the FPC manufacturers.

■ Packaging Specifications

● Embossed Carrier Tape Dimensions

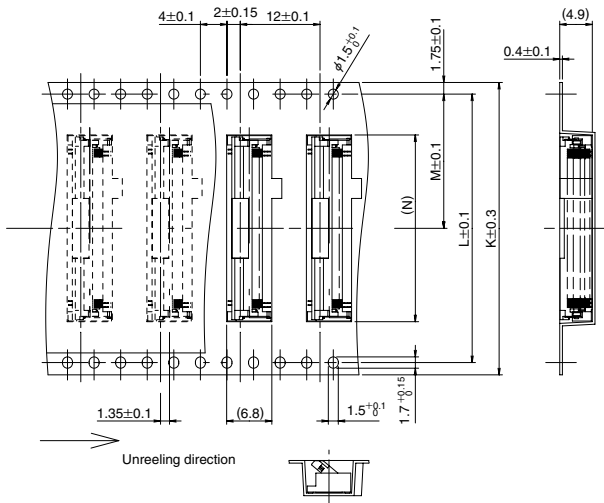

● Reel Dimensions

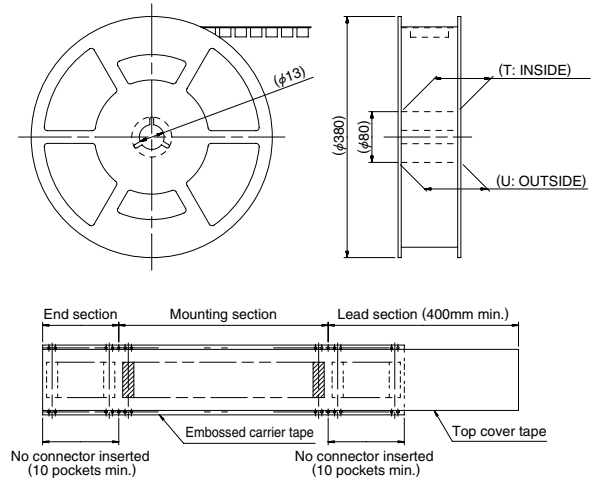

All dimensions: mm

Part Number	CL No.	Number of Contacts	K	L	M	N	T	U
FH30-60S-0.3SHW(05)	580-0105-8-05	60	44	40.4	20.2	22.1	45.4	49.4
FH30-80S-0.3SHW(05)	580-0100-4-05	80	44	40.4	20.2	28.1	45.4	49.4
FH30-90S-0.3SHW(05)	580-0106-0-05	90	44	40.4	20.2	31.1	45.4	49.4
FH30M-80S-0.4SHW(05)	580-0102-0-05	80	56	52.4	26.2	36	57.4	61.4
FH30M-96S-0.4SHW(05)	580-0103-2-05	96	56	52.4	26.2	42.4	57.4	61.4

Tape and reel packaging (1,000 pieces/reel).

■ Temperature Profile

● Using Lead-free Solder Paste

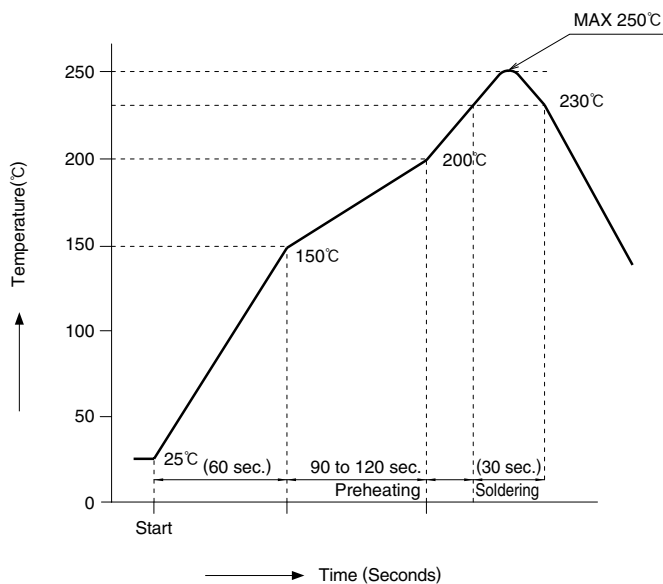

HRS test condition

- Solder method :Reflow, IR/hot air
- Environment :Room air
- Solder composition :Paste, 96.5%Sn/3.0%Ag/0.5%Cu
(Senju Metal Industry, Co., Ltd.'s Part Number:M705-221CM5-32-10.5)
- Test board :Glass epoxy FH30:45×80×1.6mm thick
FH30M:70×130×1.6mm thick
- Land dimensions :0.3mm×1.7mm
- Metal mask :0.15mm thick
0.25mm×1.7mm

The temperature profiles shown are based on the above conditions.

In individual applications the actual temperature may vary, depending on solder paste type, volume / thickness and board size / thickness. Consult your solder paste and equipment manufacturer for specific recommendations.

■ Operation and Precautions

Operation and Precautions

- 1 Install on the PC board with the actuator open.

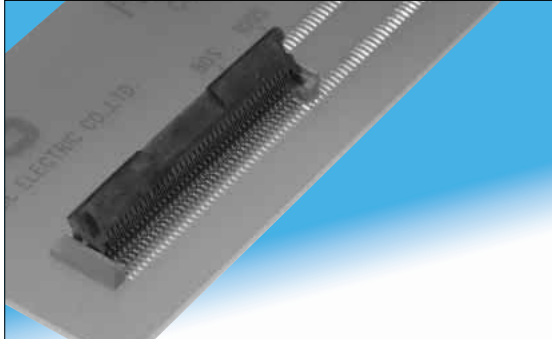

- 2 FPC Insertion

Orient the FPC with the contact pads facing down. Insert in the connector at an angle, assuring that the positioning tabs are placed in the corresponding positioning tab areas on both sides of the insulator body.

Lower the FPC to a position parallel to the mounting surface.

Verify the correct position by slightly pulling horizontally on the FPC.

Positioning tab area (each side)

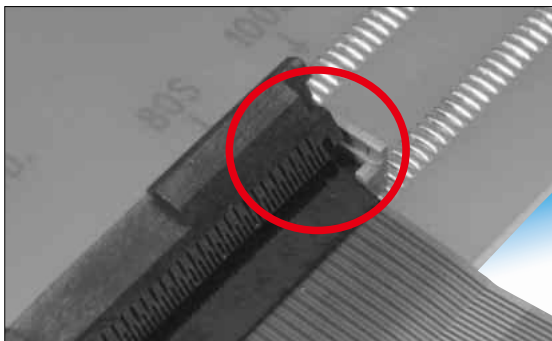
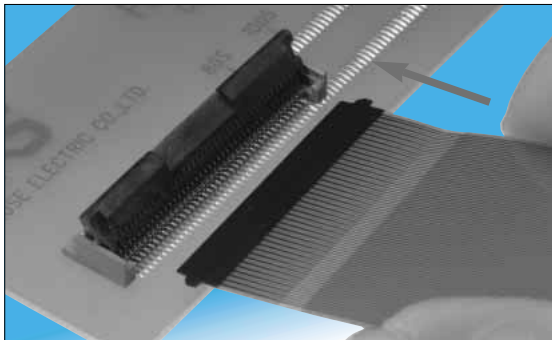

Positioning part

- 3 Actuator closing after the FPC is fully inserted. Rotate the actuator down to a full stop, pushing it at the center.

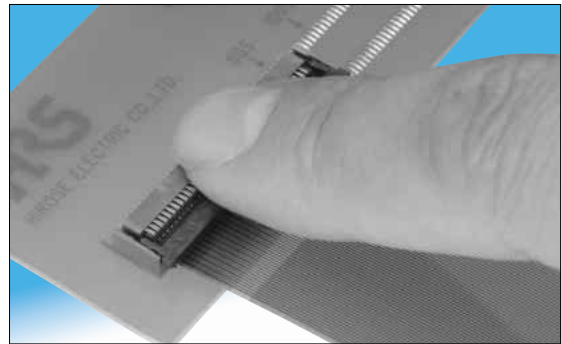
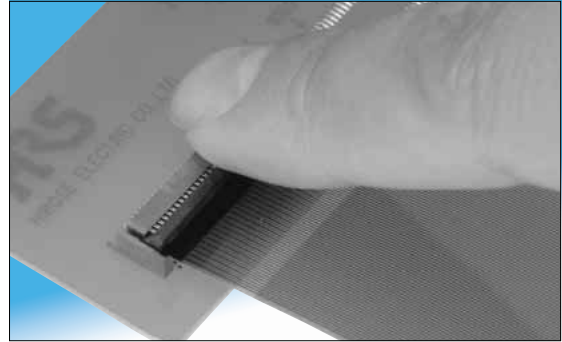

- 4 Removing the FPC

Carefully rotate the actuator up, lifting it at the center. Lift the FPC slightly to clear the positioning tabs and withdraw it from the connector.

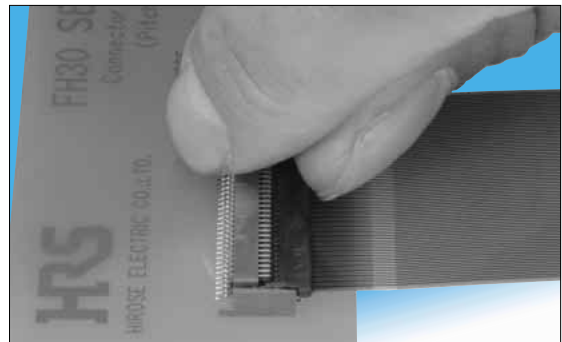

■ Precautions

Operation and Precautions

① Actuator operation

The actuator rotates at the center of its shaft, as illustrated in the figure below.

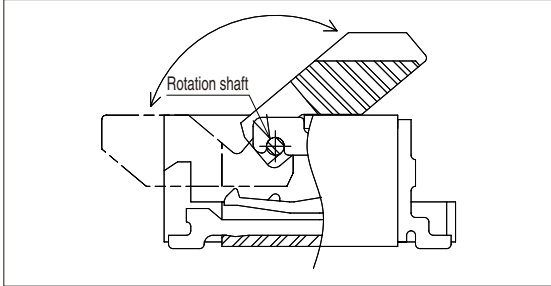

Be careful not to apply excessive force when operating the actuator from the open position (before the FPC has been inserted).

Exercise care not to touch the contacts with fingernails or any other object.

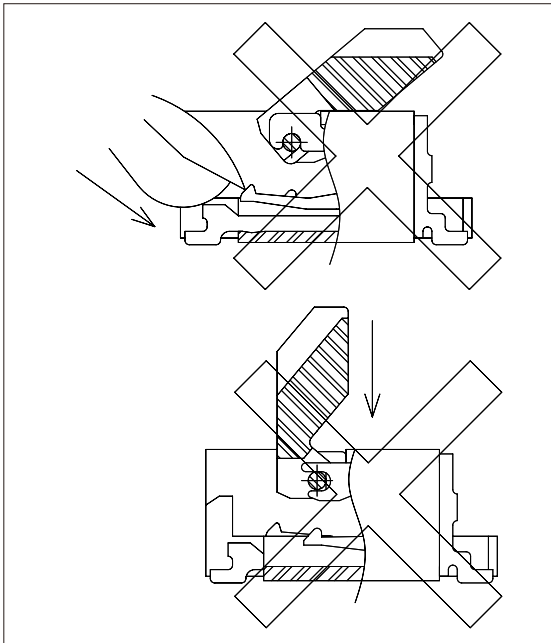

During the closing of the actuator do not pull up or push on it directly down.

Do not grasp the actuator and pull on it (photograph below).

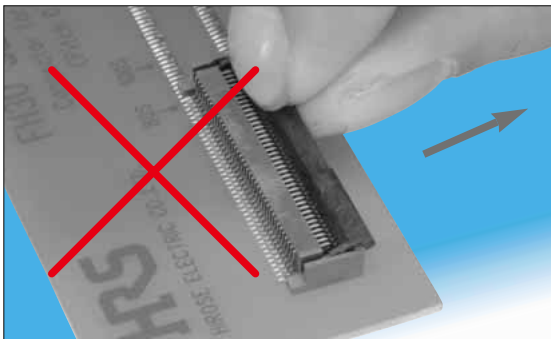

② FPC Insertion and closing of the actuator.

Do not insert the FPC on an angle as illustrated in the photograph below.

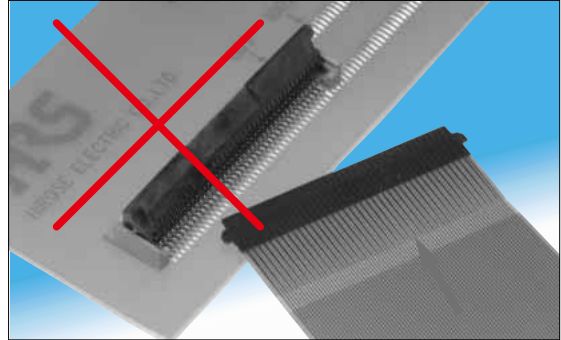

Properly insert the FPC positioning tabs into the corresponding areas on both sides of the insulator body.

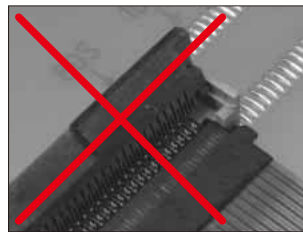

Incorrect FPC insertion

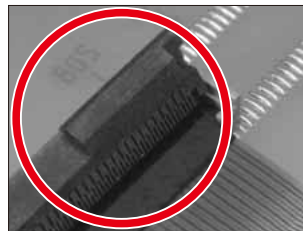

Correct FPC insertion

③ Make sure that the FPC does not rub against the insertion slot or the contacts, as illustrated on the figure below.

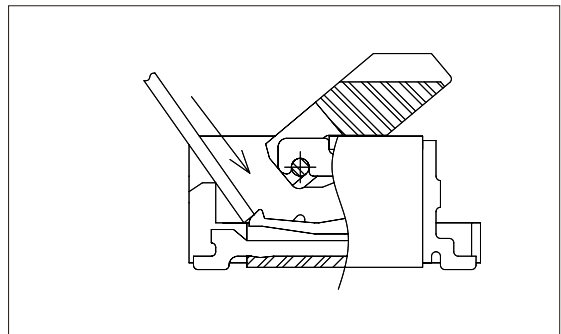

Operation and Precautions

Closing of the actuator.
 Rotate down pushing it at the center or evenly at each end, as shown on the photographs below. Do not push at one end only.

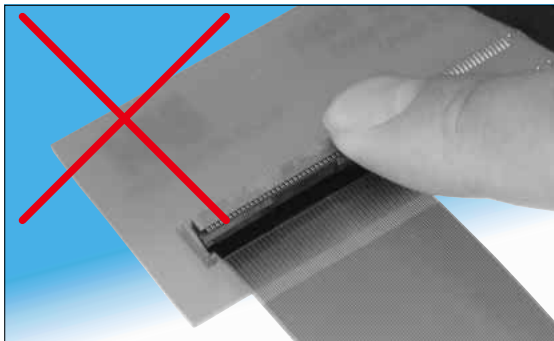
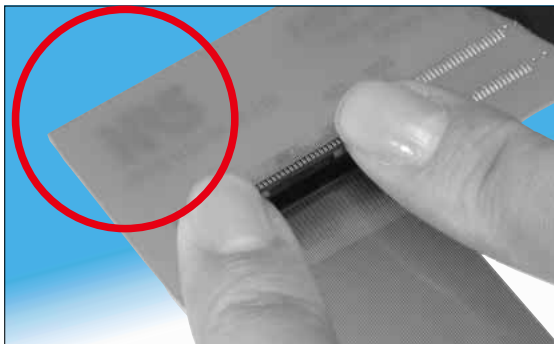
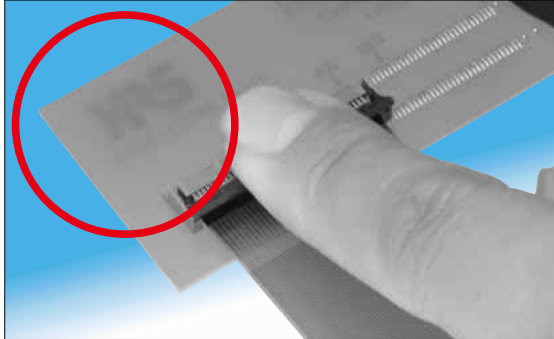

④ Opening of the actuator
 Rotate up, lifting it at the center or evenly at each end of the actuator.
 Do not lift at one end only.

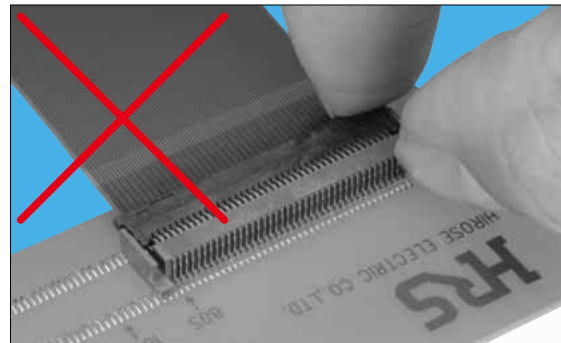
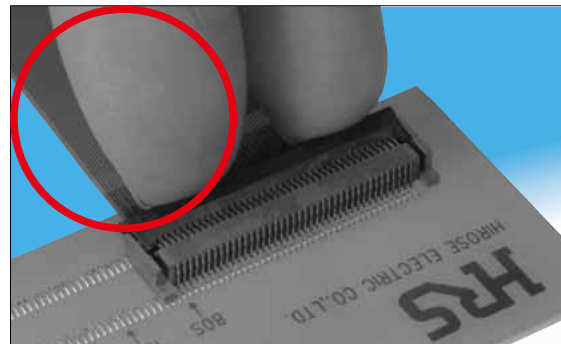
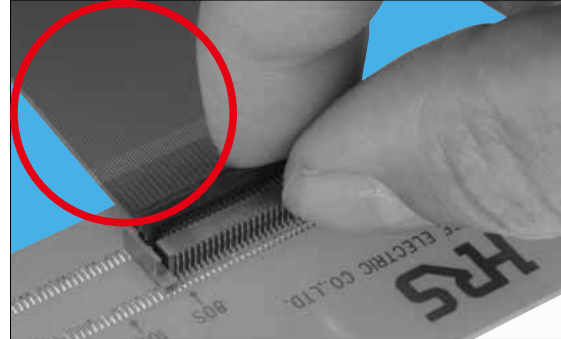

⑤ Forces to the FPC after insertion and closing of the actuator.
 Do not apply upward pull-force to the FPC close to the connector.
 If a need arise to route the FPC upward, assure that it is NOT transferring any forces to the closed actuator.

