

MICRO SWITCH
a Honeywell Division

SWITCH - ENCLOSED

CATALOG LISTING
ML-1400

NOTES

- 1 - COINCIDENCE OF OPERATING AND RELEASING POINTS: .010 OF PLUNGER TRAVEL
- 2 - CORROSION RESISTANT STEEL ENCLOSURE AND PLUNGER
- 3 - SWITCH SEALED PER MIL-PRF-8805, SYMBOL 4
- 4 PRINT CIRCUIT DIAGRAM, CATALOG LISTING, DATE CODE, AND SWITCH *1 OR SWITCH *2 (AS APPROPRIATE) ON NAMEPLATE
- 5 - PLASTIC MATERIAL(S) CONFORM TO MIL-M-14 OR MIL-M-24519
- 6 LABEL WITH MANUFACTURER'S PART NUMBER, CAGE CODE, AND DATE CODE HERE
- 7 - TEMPERATURE RATING: -65°F TO +236°F
- 8 - NOTED ELECTRICAL RATING APPLIED TO 236°F
- 9 - SHOCK QUALIFIED TO 100g
- 10 HARDWARE MAY BE PACKAGED UNASSEMBLED PER MIL-PRF-8805
- 11 - ICING QUALIFIED PER MIL-PRF-8805
- 12 - MINIMUM ELECTRICAL LIFE AT RATED LOAD: 35,000 CYCLES
- 13 - MINIMUM MECHANICAL ENDURANCE: 35,000 CYCLES
- 14 - QUALIFIED FOR SAND AND DUST PER MIL-STD-810, METHOD 510.3
- 15 - QUALIFIED FOR HUMIDITY PER MIL-STD-810, METHOD 507.3
- 16 - QUALIFIED TO 500 HOURS CONTINUOUS EXPOSURE TO SALT FOG PER MIL-STD-810, METHOD 509.3
- 17 MOUNTING PANEL THICKNESS: .120 MINIMUM
- 18 5X NO. 22 LEAD WIRE PER MIL-W-22759/7 MARKED WITH CIRCUIT IDENTIFICATION AND WIRE GAGE (1-22, 2-22, ETC..) PER MIL-W-5088
- 19 8X NO. 22 LEAD WIRES MARKED PER MIL-W-22759/7 MARKED WITH CIRCUIT IDENTIFICATION AND WIRE GAGE (1-22, 2-22, ETC..) PER MIL-W-5088
- 20 ORIGINAL DESIGN ACTIVITY CAGE CODE 60198 SAINT SWITCH INC. ST. CHARLES, ILL. 60174 (DESIGN AND PRODUCTION RIGHTS OF THIS PRODUCT PURCHASED BY HONEYWELL AS OF JUNE 1999)
- 21 5PTC0002-BC FOR PRODUCT MANUFACTURED PRIOR TO DATE CODE 0815 OR 5PTC0002-BC WITH 687A335XB11K SADDLE CLAMP KIT FOR PRODUCT MANUFACTURED UP TO DATE CODE 0852

WARNING- THIS PRODUCT IS SUBJECT TO THE U.S. INTERNATIONAL TRAFFIC IN ARMS REGULATIONS (ITAR), AND THE EXPORT CONTROL LAWS OF THE UNITED STATES. TRANSFER OF TECHNICAL DATA PERTAINING TO THIS PRODUCT BY ANY MEANS TO A FOREIGN PERSON PER ITAR DEFINITIONS, WHETHER IN THE UNITED STATES OR ABROAD, WITHOUT A PRIOR EXPORT LICENSE OR OTHER APPROVAL FROM THE U.S. DEPARTMENT OF STATE, IS PROHIBITED.

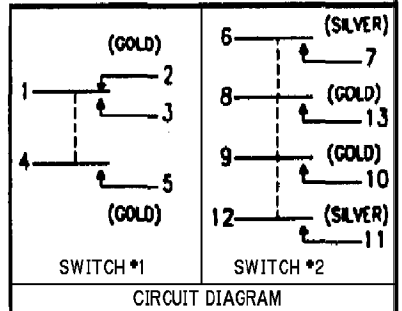
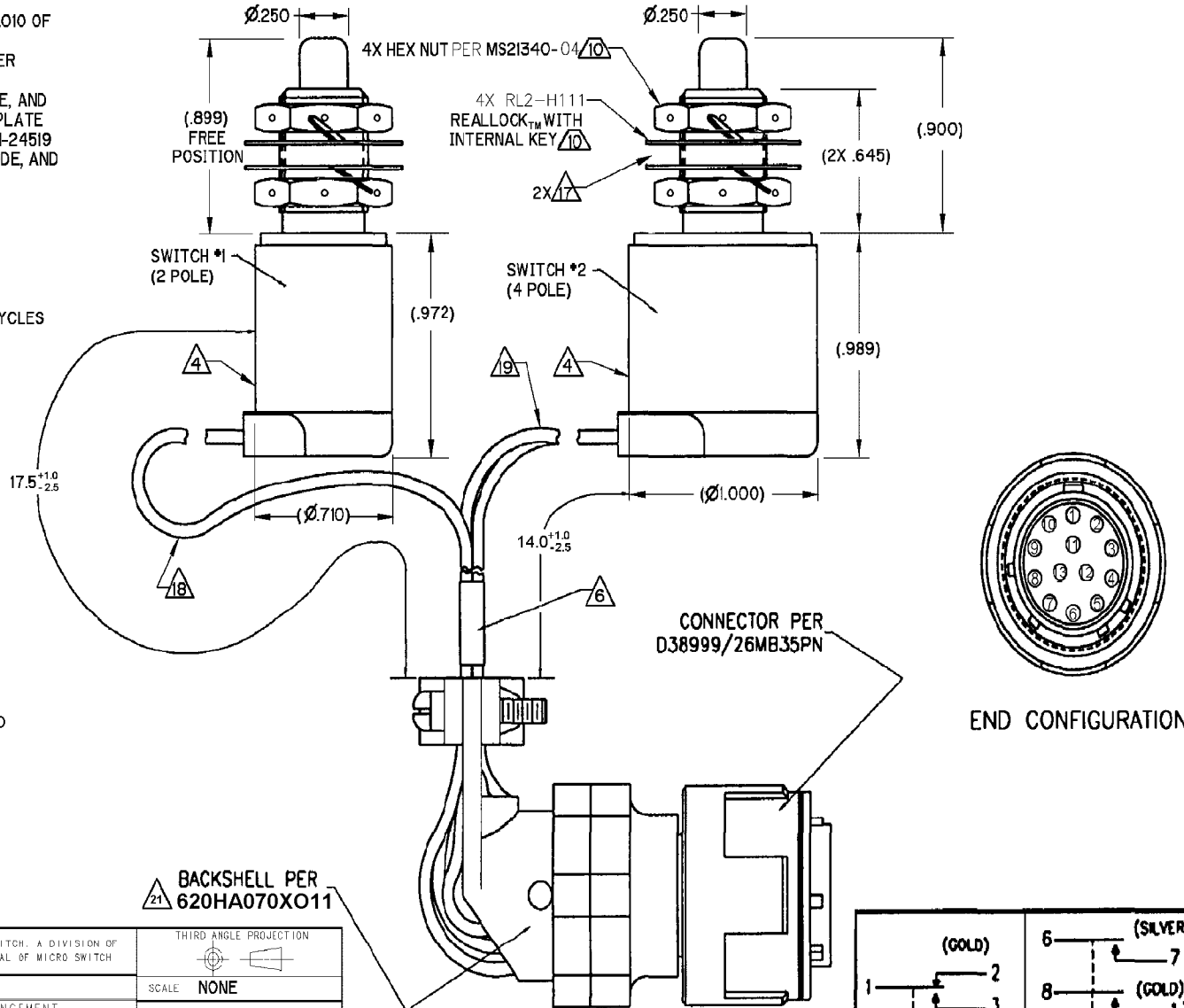

ML-1400
 CATALOG LISTING
 PAGE 1 OF 1
 RELEASE NO. PR-24174
 20 MAY 08
 BLR
 5 MAY 08
 CMH
 9 NOV 99
 S A V I
 9 NOV 99
 J J A
 RASTER
 9 NOV 99

CHARACTERISTICS (PER SWITCH)		ELECTRICAL DATA	
OPERATING FORCE -----	4 - 8 LBS	CONTACT ARRANGEMENT	
FULL OVERTRAVEL FORCE----	20 LBS MAX	LOAD (AMPS)	28 VDC SEA LEVEL
RELEASE FORCE -----	2 LBS MIN	RESISTIVE	7 .5
PRETRAVEL -----	.025 MAX	INDUCTIVE	4 .25
DIFFERENTIAL TRAVEL----	.020 MAX		SILVER GOLD
OVERTRAVEL -----	.230 MIN		

THIRD ANGLE PROJECTION	
SCALE	NONE
DO NOT SCALE PRINT	
UNLESS OTHERWISE SPECIFIED TOLERANCES ARE	
ONE PLACE (.01)	±.030
TWO PLACE (.00)	±.015
THREE PLACE (.000)	±.005
ANGLES	±
WEIGHT	

ANSI Y14.5M-1982 APPLIES