

**MICRO SWITCH**  
a Honeywell Division

**SWITCH - ENCLOSED**

CATALOG LISTING  
**ML-1454**

FED. MFG. CODE 91829 

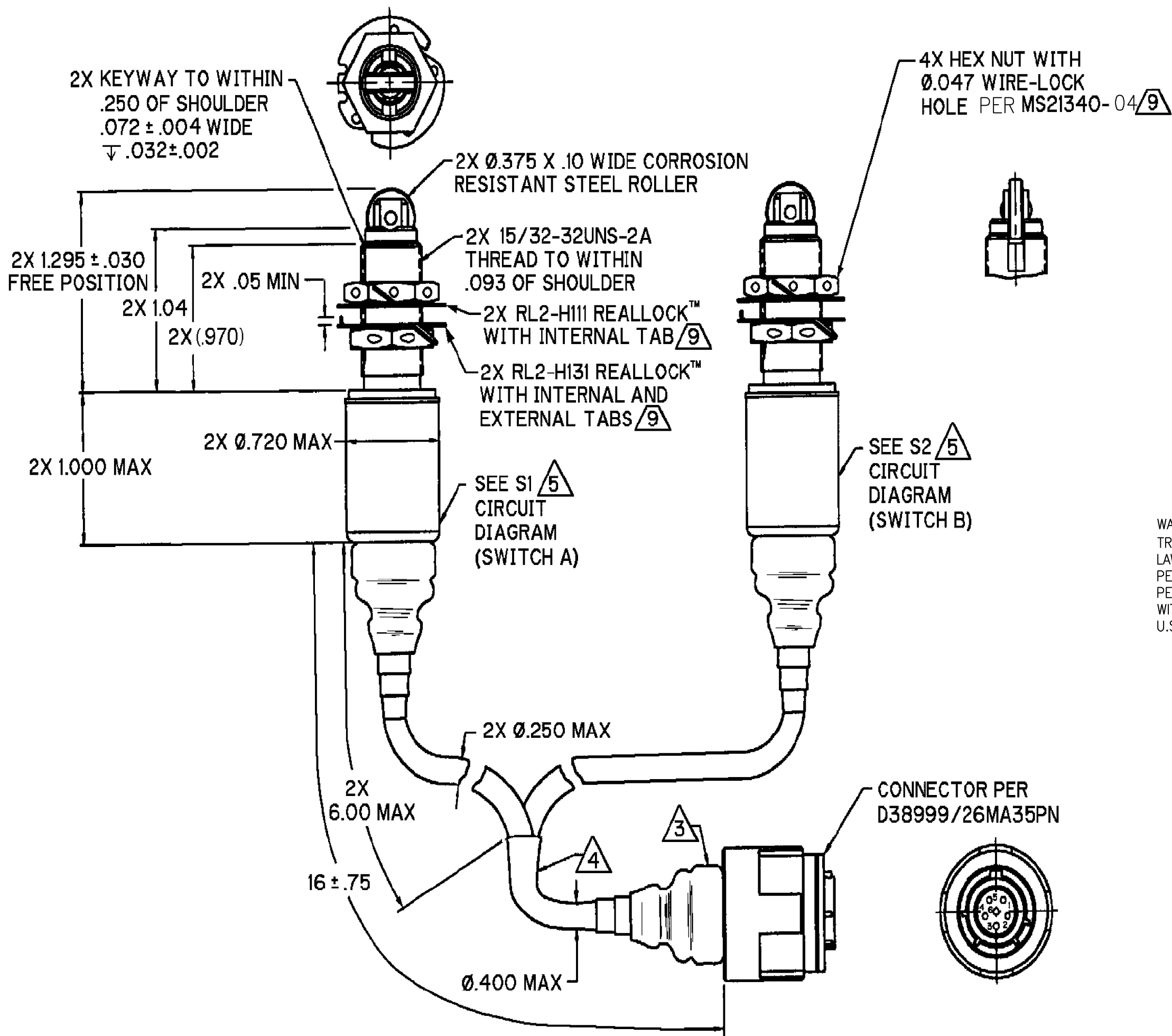
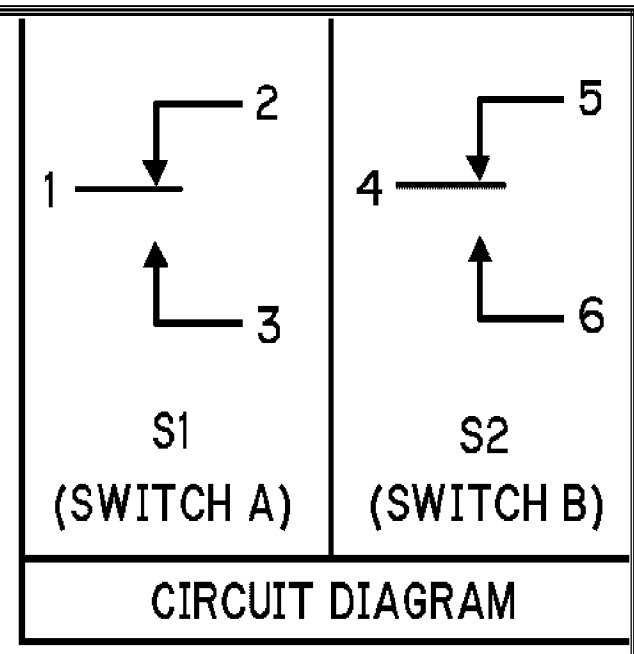









WARNING- THIS PRODUCT IS SUBJECT TO THE U.S. INTERNATIONAL TRAFFIC IN ARMS REGULATIONS (ITAR), AND THE EXPORT CONTROL LAWS OF THE UNITED STATES. TRANSFER OF TECHNICAL DATA PERTAINING TO THIS PRODUCT BY ANY MEANS TO A FOREIGN PERSON PER ITAR DEFINITIONS, WHETHER IN THE UNITED STATES OR ABROAD, WITHOUT A PRIOR EXPORT LICENSE OR OTHER APPROVAL FROM THE U.S. DEPARTMENT OF STATE, IS PROHIBITED.

**ML-1454**  
 CATALOG LISTING  
 PAGE 1 OF 1  
 REPLACES  
 PR-24178  
 07JAN11  
 RELEASE NO.  
 KNR  
 CHECK  
 04JAN06  
 05 OCT 99  
 5 OCT 99  
 07JAN11  
 MBH  
 DRAWN  
 RASTER

REVISIONS

A	203632	TSM	20 AUG 01
B	206119	DLT	31 JUL 02
C	0013844	NM	27 JUN 05
D	0014684	PH/AP	23 JUL 05
E	0017207	NM	04 JAN 06
F	0073223	MBH	07 JAN 11

THIS DRAWING COVERS A PROPRIETARY ITEM AND IS THE PROPERTY OF MICRO SWITCH, A DIVISION OF HONEYWELL. THIS DRAWING IS NOT TO BE COPIED OR USED WITHOUT THE APPROVAL OF MICRO SWITCH		THIRD ANGLE PROJECTION	
<b>CHARACTERISTICS</b> 		<b>ELECTRICAL DATA</b>	
OPERATING FORCE ----- 6-12 LBS		CONTACT ARRANGEMENT	
FULL OVERTRAVEL FORCE ----- 30 LBS MAX		2X SPDT 	
RELEASE FORCE ----- 4 LBS MIN		LOAD (AMPS)	
PRETRAVEL ----- .040 MAX		28 VDC	
DIFFERENTIAL TRAVEL ----- .020 MAX		SEA LEVEL	
OVERTRAVEL ----- .125 MIN		50,000 FT	
RES	1	1	
IND	.5	.5	
MOTOR			
		SCALE NONE	
		DO NOT SCALE PRINT	
		UNLESS OTHERWISE SPECIFIED TOLERANCES ARE	
		ONE PLACE (.0) ± .030	
		TWO PLACE (.00) ± .015	
		THREE PLACE (.000) ± .005	
		ANGLES ±	
		WEIGHT	

- NOTES**
-  GOLD CONTACT BASIC SWITCHES
  -  CHARACTERISTICS APPLY TO BOTH SWITCH ASSEMBLIES S1 AND S2
  -  STRESS RELIEF PER MS 23053/4 CLASS III
  -  HEAT SHRINK PER MS23053/4 CLASS II
  -  PRINT CIRCUIT DIAGRAM, CATALOG LISTING AND DATE CODE ON NAMEPLATE
  - 6 - CORROSION RESISTANT STEEL ENCLOSURE, ROLLER AND ROLLER GUIDE
  - 7 - SWITCH ASSEMBLIES SEALED PER MIL-PRF-8805 SYMBOL 4
  - 8 - TEMPERATURE RANGE: -65° TO 260° F
  -  HARDWARE MAY BE PACKAGED UNASSEMBLED PER MIL-PRF-8805
  -  ORIGINAL DESIGN ACTIVITY CAGE CODE 60198
- SAINT SWITCH INC.  
ST. CHARLES, ILL. 60174  
(DESIGN AND PRODUCTION RIGHTS OF THIS PRODUCT PURCHASED BY HONEYWELL AS OF JUNE 1999)