

**SERIES**  
AMPLIFIED  
(4V SPAN)

**DCAL4**      **N**

**PACKAGE TYPE**  
**N** - PLASTIC

**PRESSURE RANGE**  
**01, 05, 10,**  
**20, 30** IN H<sub>2</sub>O

**PRESSURE REFERENCE**  
**D** - DIFFERENTIAL  
**G** - GAGE

CATALOG LISTINGS	
DCAL401DN	②
DCAL401GN	②
DCAL405GN	③
DCAL410DN	②
DCAL410GN	③
DCAL430GN	②

**NOTES**

△ REFERENCE CONDITIONS (UNLESS OTHERWISE NOTED): SUPPLY VOLTAGE,  $V_s = 5$  Vdc,  $T_A = 25^\circ\text{C}$ , COMMON MODE LINE PRESSURE = 0 PSIG. PRESSURE MEASUREMENTS ARE WITH PRESSURE APPLIED TO PORT 2

② HI/LO SPAN IS THE ALGEBRAIC DIFFERENCE BETWEEN OFFSET OUTPUT AND HI OR LO OUTPUTS

③ SHIFT IS RELATIVE TO  $25^\circ\text{C}$

④ SHIFT IS WITHIN THE FIRST HOUR OF EXCITATION APPLIED TO THE DEVICE

⑤ LINEARITY IS DETERMINED USING BEST STRAIGHT LINE CURVE FIT THROUGH ZERO, 1/2 FULL SCALE, AND FULL SCALE; HYSTERESIS IS MECHANICAL ONLY

⑥ SPAN IS THE ALGEBRAIC DIFFERENCE OF OUTPUT END POINTS (OUTPUT AT SPECIFIED HI AND LOW OUTPUT LIMITS)

ELECTRICAL SPECIFICATIONS						
PARAMETER		PRESSURE RANGE (in H <sub>2</sub> O)	MIN	NOM	MAX	UNITS
DIFFERENTIAL	OFFSET VOLTAGE (NULL AT 0 in H <sub>2</sub> O)	ALL	2.150	2.250	2.350	V
	HI SPAN ( $P_2 > P_1$ )		1.900	2.000	2.100	
	LO SPAN ( $P_1 > P_2$ )		-1.900	-2.000	-2.100	
	SPAN (HI SPAN - LO SPAN)		---	4.000	---	
GAGE	OFFSET VOLTAGE (NULL AT 0 in H <sub>2</sub> O)	ALL	0.150	0.250	0.350	V
	SPAN ( $P_2 > P_1$ )		3.900	4.000	4.100	
DIFFERENTIAL	TEMPERATURE EFFECT ON OFFSET ( $0^\circ\text{C}$ - $50^\circ\text{C}$ )	01	---	---	±40	mV
		05, 10, 20, 30	---	---	±20	
		10, 20, 30	---	---	±20	
GAGE	TEMPERATURE EFFECT ON OFFSET ( $0^\circ\text{C}$ - $50^\circ\text{C}$ )	01	---	---	±60	mV
		05	---	---	±40	
		10, 20, 30	---	---	±20	
TEMPERATURE EFFECT ON SPAN ( $0^\circ\text{C}$ - $50^\circ\text{C}$ )		01	---	---	±2	%SPAN
		05, 10, 20, 30	---	---	±1	
OFFSET WARM-UP SHIFT		01	---	20	---	mV
		05, 10, 20, 30	---	20	---	
OFFSET POSITION SENSITIVITY ( $\pm 1g$ )		01	---	10	---	mV
		05	---	5	---	
		10, 20, 30	---	1	---	
OFFSET LONG TERM DRIFT (ONE YEAR)		ALL	---	100	---	mV
COMBINED LINEARITY AND MECHANICAL HYSTERESIS ERROR		ALL	---	0.05	0.25	%FS

MAXIMUM RATINGS					
PARAMETER	PRESSURE RANGE (in H <sub>2</sub> O)	MIN	MAX	UNITS	
OPERATING TEMPERATURE RANGE	ALL	-25	85	°C	
STORAGE TEMPERATURE	ALL	-40	125	°C	
PROOF PRESSURE (VERIFIED BY TEST)	ALL	5	---	PSIG	
BURST PRESSURE (VERIFIED BY DESIGN)	01	200	---	in H <sub>2</sub> O	
	05, 10	300	---		
	20	450	---		
	30	750	---		
EXCITATION VOLTAGE	ALL	3	16	V	
COMMON MODE PRESSURE	ALL	---	50	PSIG	

MEDIA CAPABILITY (APPLY CLEAN DRY AIR ONLY)	
PRESSURE PORT 2 (HIGH) PRESSURE MEASURING PORT	SILICON DIAPHRAGM, GLASS FILLED NYLON, AND ALUMINA CERAMIC.
PRESSURE PORT 1 (LOW) THE VENT PORT	SILICON DIAPHRAGM, GLASS FILLED NYLON, AND ALUMINA CERAMIC.

**PRESSURE COMPATIBILITY:**  
MEASURES DIFFERENTIAL OR GAGE PRESSURE ONLY WITH POSITIVE PRESSURE TO PORT 2. THERE WILL BE A SMALL OUTPUT VOLTAGE BETWEEN THE ACTUAL OFFSET VOLTAGE AND GROUND PROPORTIONAL TO VACUUM IF APPLIED TO PORT 2

**RATIOMETRIC OUTPUT:**  
THE OUTPUT VOLTAGE OF THE SENSOR IS NOMINALLY RATIOMETRIC, PROPORTIONAL, TO THE EXCITATION VOLTAGE. FOR THIS MODEL SENSOR ALL SPECIFICATIONS WILL CHANGE PROPORTIONALLY TO ANY CHANGES IN THE EXCITATION VOLTAGE. THE EXCITATION MAY VARY BETWEEN 3 TO 16 VOLTS. ALL SPECIFICATIONS WILL NOMINALLY BE CHANGED BY A RATIO OF  $V_{\text{EXCITATION}}/5.0$  VOLTS. FOR EXAMPLE: IF THE EXCITATION VOLTAGE IS 3.0 VOLTS THEN BOTH THE FULL SCALE OUTPUT VOLTAGE AND THE OFFSET VOLTAGE WOULD BE 3/5TH THE SPECIFIED VALUE

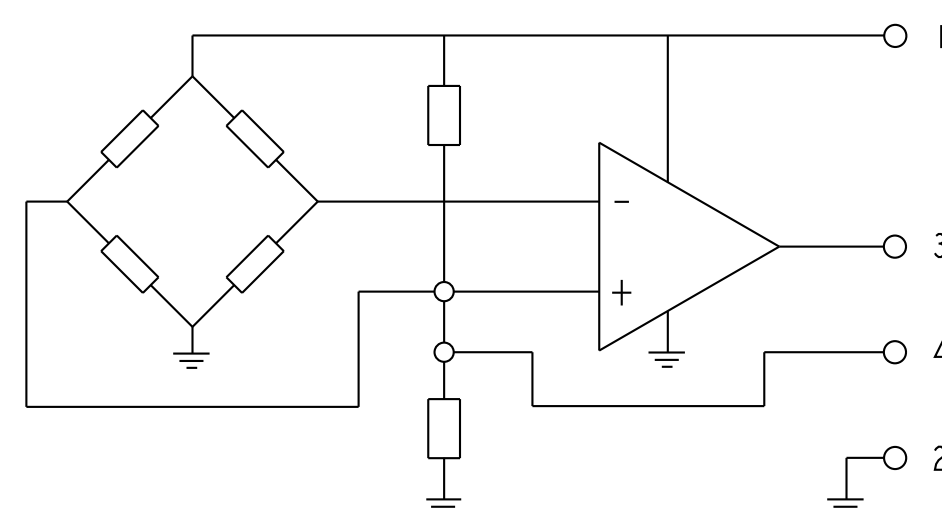
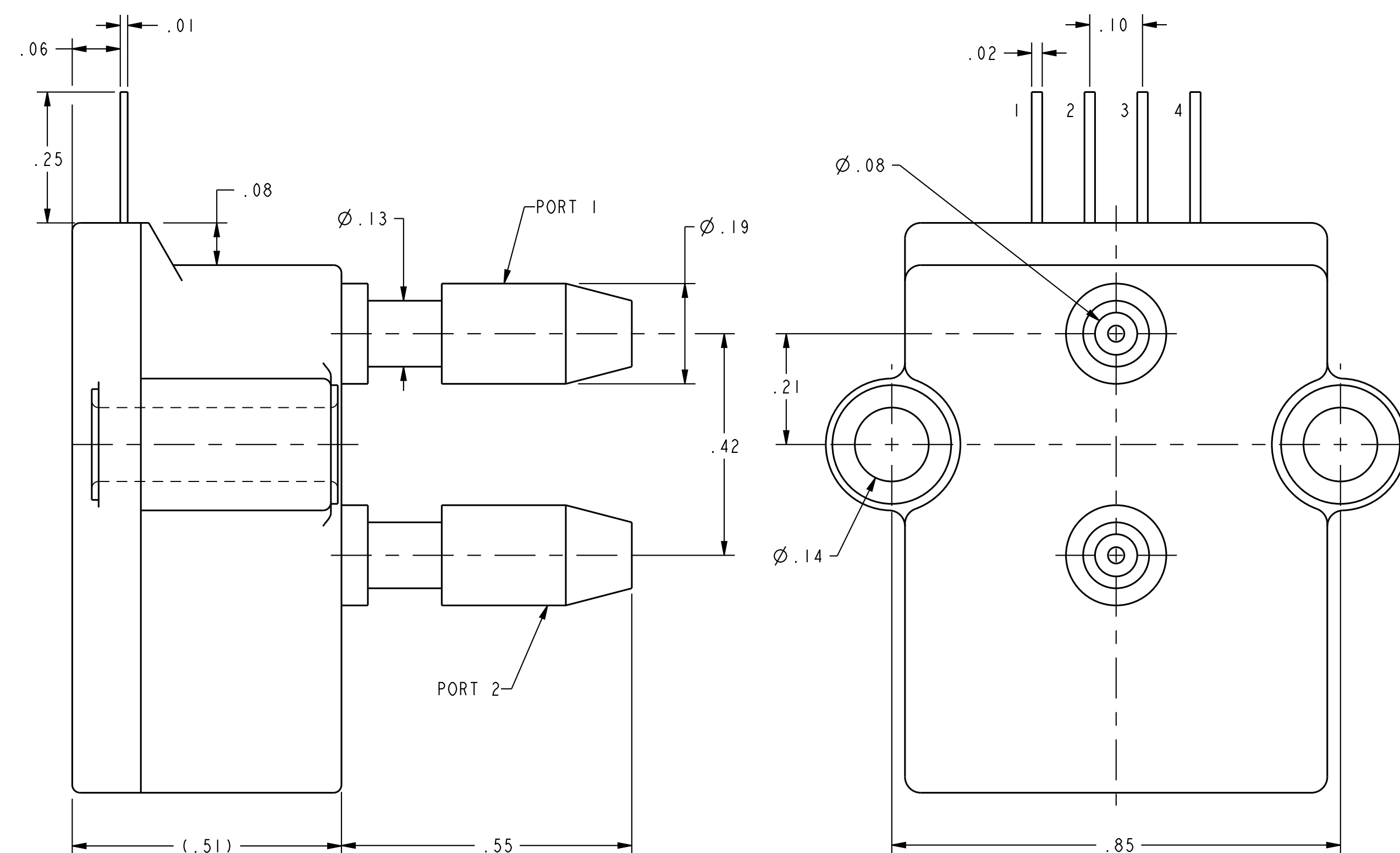
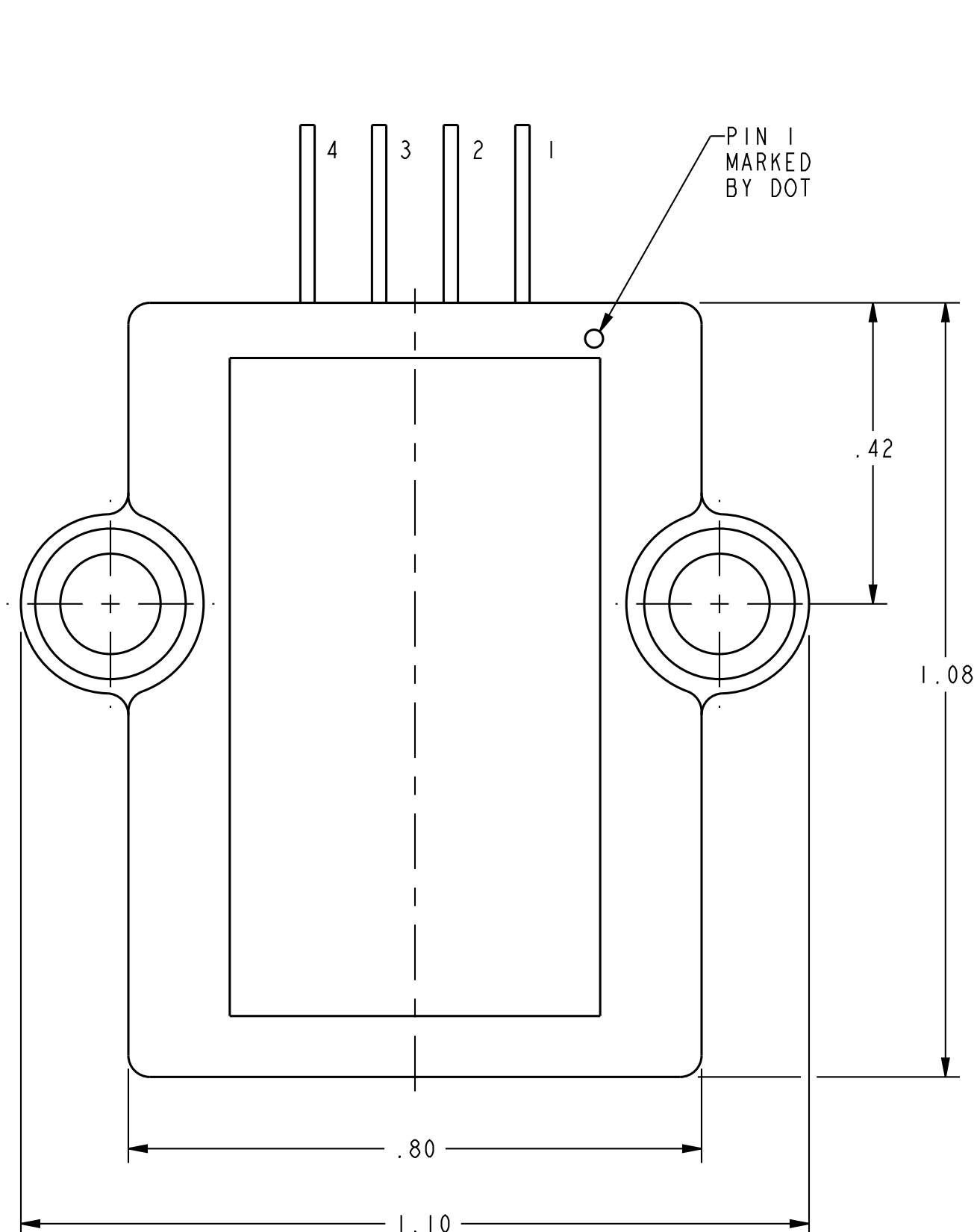

EQUIVALENT CIRCUIT

PIN OUT	
1	$V_{\text{EXCITATION}}$
2	COMMON
3	$V_{\text{OUTPUT}}$
4	$V_{\text{OFFSET}}$

UNLESS OTHERWISE SPECIFIED TOLERANCES ARE:	ASSEMBLY	INCHES	DRAWN	TRF	06OCT00
NO PLACE .X	±.040	±.1	CHECK	KNR	06OCT00
ONE PLACE .X	±.030	±0.4	THIS DRAWING COVERS A PROPRIETARY ITEM AND IS THE PROPERTY OF HONEYWELL. THIS DRAWING IS NOT TO BE COPIED OR USED WITHOUT THE PERMISSION OF HONEYWELL.		
TWO PLACE .XX	±.015	±0.15			
THREE PLACE .XXX	±.005	±			
ANGLES	±	±			
RAW MATERIAL - COMMERCIAL STANDARD			DIMENSIONS ARE TO BE MET BEFORE PROTECTIVE COATINGS ARE APPLIED		
THIRD ANGLE PROJECTION			PTC	3D	ASME Y14.5M-1994
		SIZE	DWG TYPE	DRAWING NAME	REV
		D	I	DCAL4 SERIES CHART 1	4
SCALE		5:1	WEIGHT	SHEET 1 OF 1	

**Honeywell**

**PRESSURE SENSOR**