

## Product Brief

# DC Motor Control Shield with BTN8982TA for Arduino

The DC Motor Control Shield from Infineon is one of the first high-current motor control boards being compatible to Arduino as well as to Infineon's XMC1100 Boot Kit. It is capable of driving two uni-directional DC motors (half bridge configuration) or one bi-directional DC motor (H-Bridge configuration).

The implemented NovalithIC™ integrated half-bridge driver BTN8982TA can be controlled by a PWM via the IN Pin. Interfacing to a microcontroller is made easy by the integrated driver IC which features logic level inputs, diagnosis with current sense, slew rate adjustment, dead time generation and protection against overtemperature, undervoltage, overcurrent and short circuit.

### Applications

- Brushed DC motor control up to 250W continuous load
  - 8–18V nominal input voltage (max. 6–40V)
  - Average motor current 30A restricted due to PCB (BTN8982TA current limitation @ 55A min.)

### Features

- Compatible with Arduino Uno R3 and XMC1100 Boot Kit from Infineon
- Capable of high frequency PWM, e.g. 30kHz
- Adjustable slew rates for optimized EMI by changing external resistor
- Driver circuit with logic level inputs
- Diagnosis with current sense
- Protection e.g. against overtemperature and overcurrent

### Benefits

- Fast and inexpensive prototyping of DC motor control
- Easy testing of half- and full-bridge motor control
- Status flag diagnosis with current sense capability
- Overtemperature shut down with latch behavior and undervoltage shut down

### Application Diagram of the DC Motor Control Shield

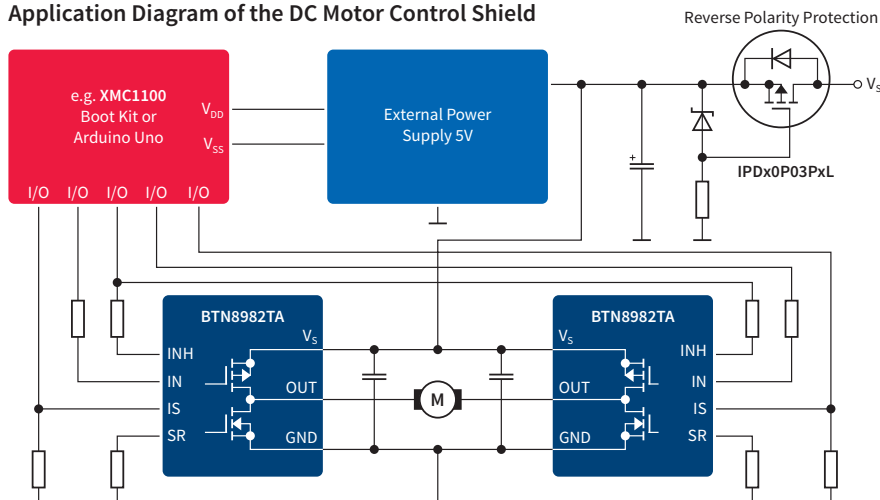

# DC Motor Control Shield

with BTN8982TA for Arduino

Block Diagram

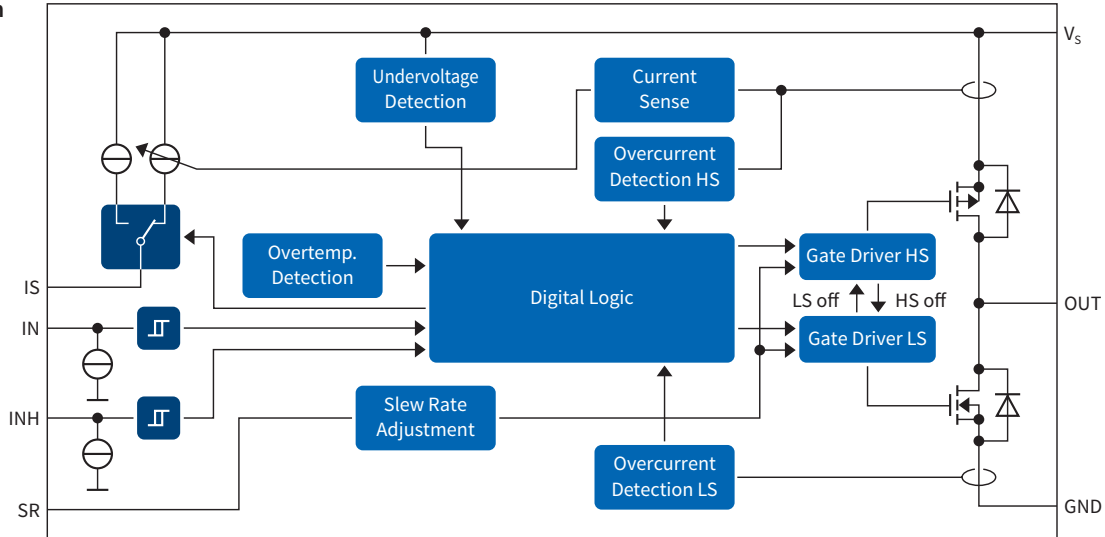

The BTN8982TA provides a cost optimized solution for protected high-current PWM motor drives with very low board space consumption.

## Product Summary

Type	Description	Ordering Code
DC Motor Control Shield with BTN8982TA for Arduino	DC Motor Control Shield with NovalithIC™ integrated half-bridge driver BTN8982TA – and IPD90P04P4L for reverse polarity protection. For the evaluation of brushed DC motor control applications up to 250W continuous load. Compatible with Arduino Uno R3 and XMC1100 Boot Kit.	DCMOTORCONTRBTN8982TOBO1
NovalithIC BTN8982TA	The BTN8982TA is an integrated high-current half-bridge for motor drive applications. It is part of the NovalithIC™ family containing one p-channel high-side MOSFET and one n-channel low-side MOSFET with an integrated driver IC in one package (PG-TO263-7).	BTN8982TAAUMA1
Boot Kit XMC1100	Evaluationboard for XMC1100 MCUs series with detachable SEGGER J-Link and RGB LED Lighting Shield with XMC1202 for Arduino	KIT_XMC11_BOOT_001

This device complies with Part 15 of the FCC Rules. Operation is subject to the following two conditions: (1) this device may not cause harmful interference, and (2) this device must accept any interference received, including interference that may cause undesired operation.

### Useful Links

- [www.infineon.com/arduino](http://www.infineon.com/arduino)
- [www.infineon.com/novalithIC](http://www.infineon.com/novalithIC)
- [www.infineon.com/xmc1000](http://www.infineon.com/xmc1000)



CAN ICES-3 (B)/NMB-3(B)



Published by  
Infineon Technologies AG  
85579 Neuburg, Germany

© 2015 Infineon Technologies AG.  
All Rights Reserved.

Visit us:  
[www.infineon.com](http://www.infineon.com)

Order Number: B127-I0043-V1-7600-EU-EC-P  
Date: 01 / 2015

### Attention please!

The information given in this document shall in no event be regarded as a guarantee of conditions or characteristics ("Beschaffenheitsgarantie"). With respect to any examples or hints given herein, any typical values stated herein and/or any information regarding the application of the device, Infineon Technologies hereby disclaims any and all warranties and liabilities of any kind, including without limitation warranties of non-infringement of intellectual property rights of any third party.

### Information

For further information on technology, delivery terms and conditions and prices please contact your nearest Infineon Technologies Office ([www.infineon.com](http://www.infineon.com)).

### Warnings

Due to technical requirements components may contain dangerous substances. For information on the types in question please contact your nearest Infineon Technologies Office. Infineon Technologies Components may only be used in life-support devices or systems with the express written approval of Infineon Technologies, if a failure of such components can reasonably be expected to cause the failure of that life-support device or system, or to affect the safety or effectiveness of that device or system. Life support devices or systems are intended to be implanted in the human body, or to support and/or maintain and sustain and/or protect human life. If they fail, it is reasonable to assume that the health of the user or other persons may be endangered.