

ISL8115EVAL1Z Synchronous Buck Converter User Guide

Introduction

The ISL8115EVAL1Z is a Synchronous Buck Converter implementing Intersil's wide input range PWM controller ISL8115. Utilizing voltage mode control with input feed-forward, the ISL8115EVAL1Z maintains a constant loop gain for optimal transient response, especially for applications with a wide input voltage range. For a more detailed description of the ISL8115 functionality, refer to the [ISL8115 data sheet](#).

This application note includes the test setup, typical performance waveforms, schematic, layout and Bill of Materials (BOM).

Evaluation Board Specifications

TABLE 1. EVALUATION BOARD ELECTRICAL SPECIFICATIONS

| SPEC | DESCRIPTION | MIN | TYP | MAX | UNIT |
|------------------|------------------------|-----|-------|-----|------|
| V _{IN} | Board Input Range | 10 | 12 | 15 | V |
| V _{OUT} | Output Voltage | | 1.5 | | V |
| I _{OUT} | Output Rated Current | | 30 | | A |
| I _{OC} | Overcurrent Threshold | | 32 | | A |
| F _{sw} | Switch Frequency | | 220 | | kHz |
| Input UVP | Rising threshold | | 9.7 | | V |
| | Falling threshold | | 9.2 | | V |
| η | Efficiency at 50% load | | 90.88 | | % |



FIGURE 1. ISL8115EVAL1Z EVALUATION BOARD

ISL8115 Key Features

- Wide V_{IN} range operation: 2.97V to 36V; up to 5.5V output and 30A load current per phase.
- Fast transient response
 - Voltage-mode PWM leading-edge modulation with non-linear control
 - Input voltage feed-forward
- Integrated 5V high speed 4A MOSFET gate drivers
 - Internal bootstrap diode
- Oscillator programmable from 150kHz to 1.5MHz
 - Frequency synchronization to external clock signal
- Diode emulation mode for light load efficiency improvement
- Output OVP/UVP; OCP and OTP
- Power-good open drain output
- Adjustable soft-start
- Pre-bias start-up function
- Excellent output voltage regulation
 - 0.6V ±1.0% internal reference (-40 °C~125 °C)
 - 0.6V ±0.7% internal reference (-40 °C~105 °C)
 - Differential voltage sensing

Applications

- Power supply for datacom/telecom and POL
- Wide input voltage range buck regulators
- High current density power supplies RF power amplifier bias compensation

Recommended Equipment

- Input power source up to 15V supply voltage with 60W power supply ability
- Electronic load with 50W power sinking ability
- Voltmeters and ammeters
- 100MHz quad-trace oscilloscope

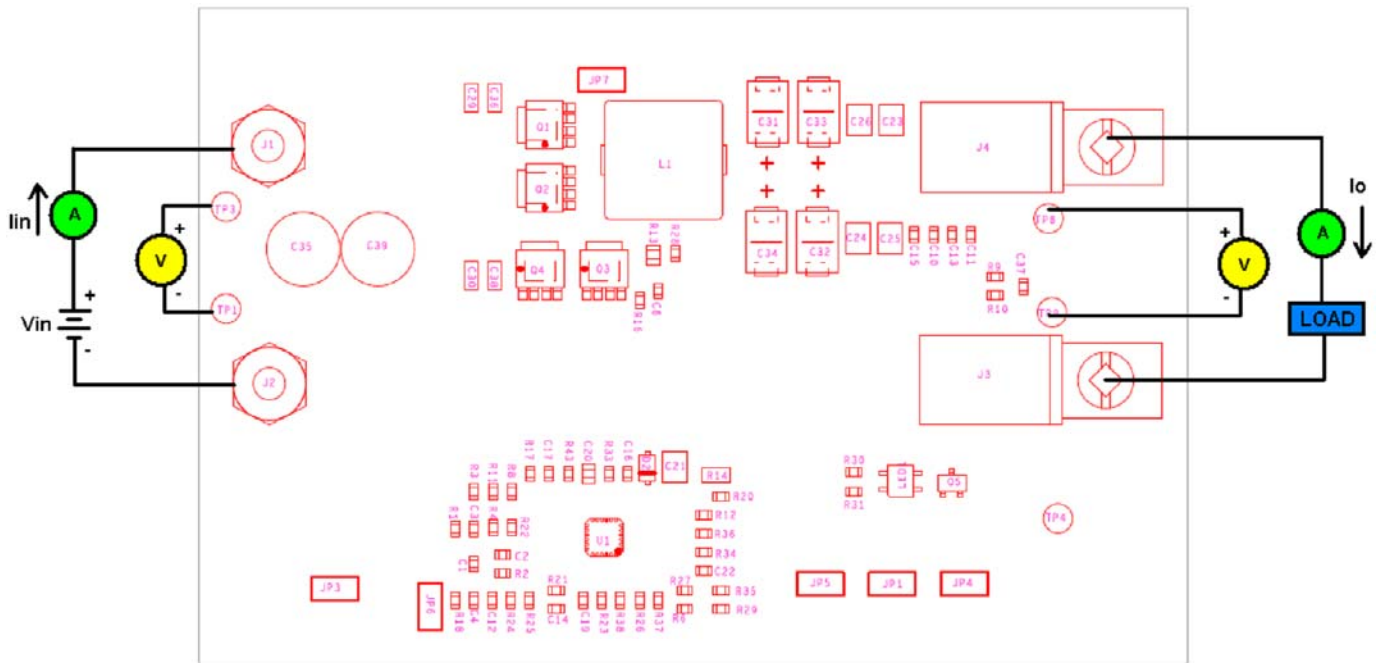

FIGURE 2. ISL8115EVAL1Z TEST SET-UP

Quick Test Setup

1. Ensure that the Evaluation board is correctly connected to the power supply and the electronic load prior to applying any power. Please refer to Figure 2 for proper set-up.
2. Set the input voltage to 12V, turn on the power supply and observe output voltage. The output voltage should variation should be within 5%.
3. Adjust load current within 30A. The output voltage variation should be within 5%.
4. Use oscilloscope to observe output ripple voltage and phase node ringing. For accurate measurement, please refer to Figure 3 for proper set-up.

Note: Test points TP1; TP3; TP8; TP9 are for voltage measurement only. Do not allow high current through these test points.

Probe Set-up

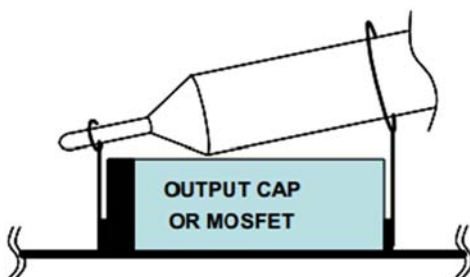

FIGURE 3. OSCILLOSCOPE PROBE SET-UP

Design Guide

The ISL8115EVAL1Z is optimized for 10V to 15V input voltage range. However, the evaluation board can be modified to support multiple applications due to the customer requirements. Please refer to the datasheet for the detailed information.

Output Voltage Adjustment

The output voltage can be set by the resistor R4, R1. In order to keep the existing compensation parameters unchanged, adjust R4 to set the output voltage by the following Equation 1:

$$R4 = \frac{0.6V \times R1}{V_{out} - 0.6V} \quad (EQ. 1)$$

VMON monitors the output for UVP and OVP, the resistor divider value of R11/R8 should be the same with the R1/R4.

Synchronization

ISL8115EVAL1Z board can be synchronized with an external clock. Apply a clock signal (10% to 90% duty cycle) in the range of 150kHz to 1.5MHz to the FSET pin makes the internal frequency synchronized with the external clock. Please remove R27 when the sync function is implemented.

Application Note 1881

Typical Performance Curves Unless otherwise specified, the input voltage is 12V.

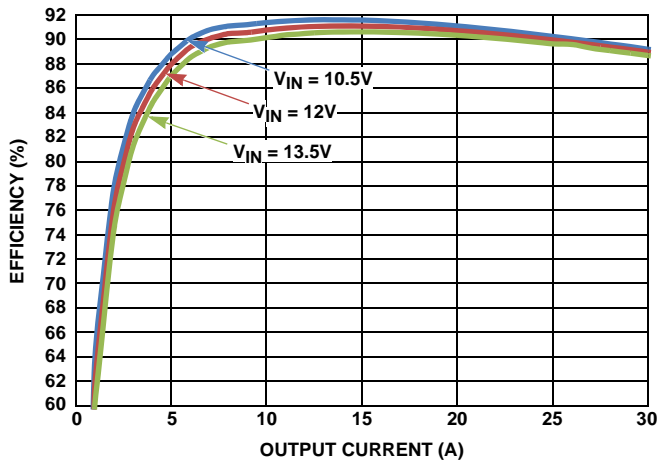

FIGURE 4. EFFICIENCY vs LOAD CURRENT AT CCM MODE

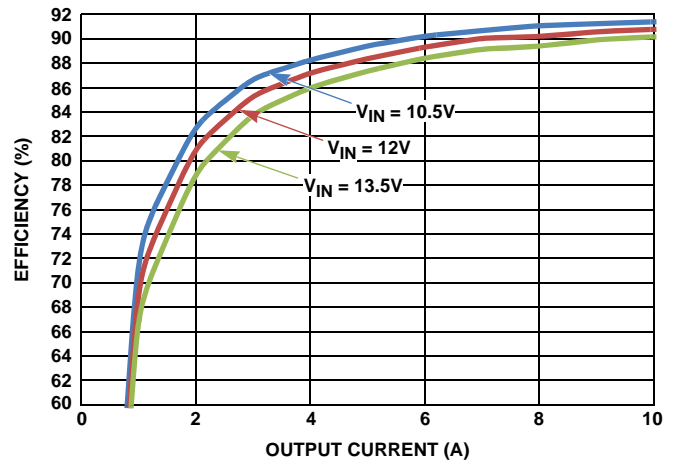

FIGURE 5. EFFICIENCY vs LOAD CURRENT AT DEM MODE

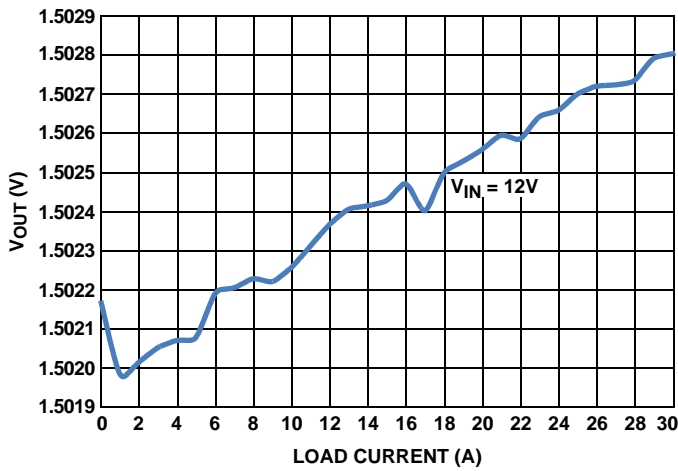

FIGURE 6. V_{OUT} LOAD REGULATION AT CCM MODE

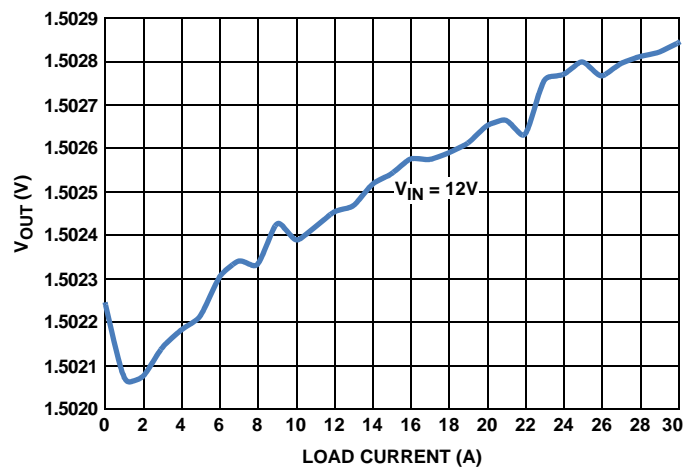

FIGURE 7. V_{OUT} LOAD REGULATION AT DEM MODE

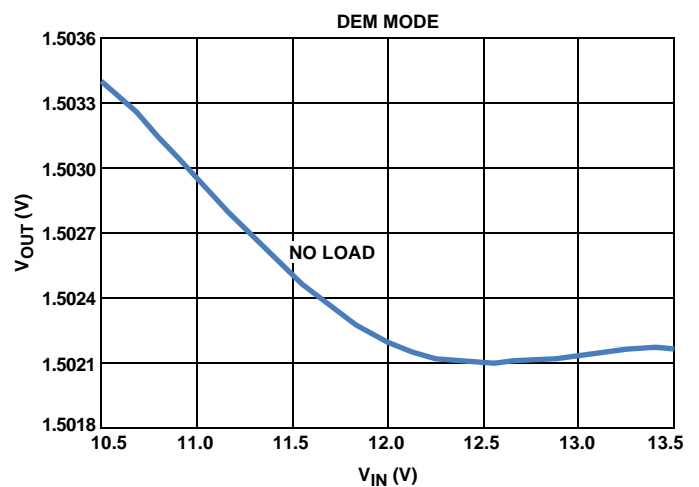
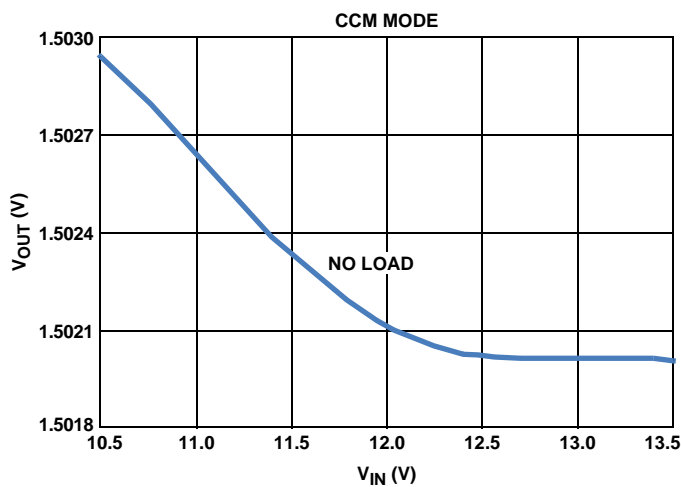

FIGURE 8. LINE REGULATION AT NO LOAD CONDITION

Application Note 1881

Typical Performance Curves Unless otherwise specified, the input voltage is 12V. (Continued)

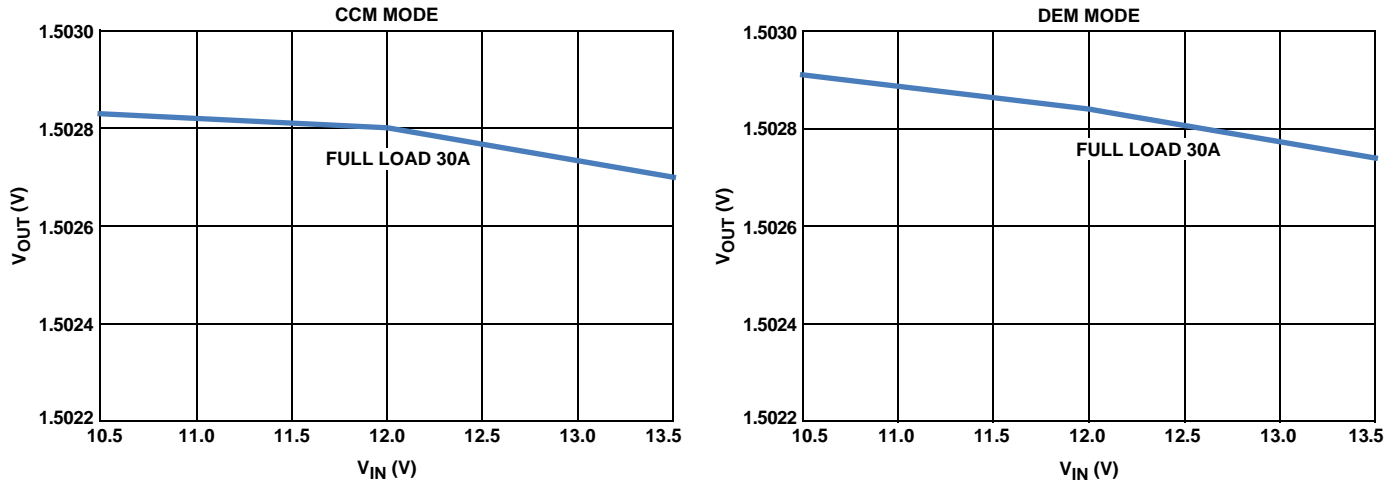

FIGURE 9. LINE REGULATION AT FULL LOAD CONDITION

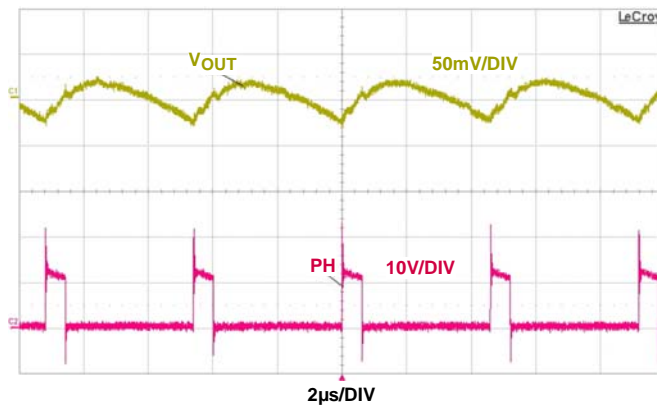

FIGURE 10. OUTPUT VOLTAGE RIPPLE AT 30A LOAD CONDITION

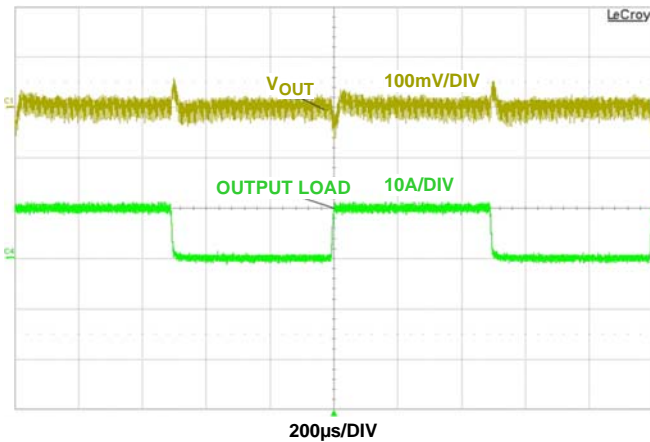

FIGURE 11. 0A-10A; 2A/µs AT CCM MODE

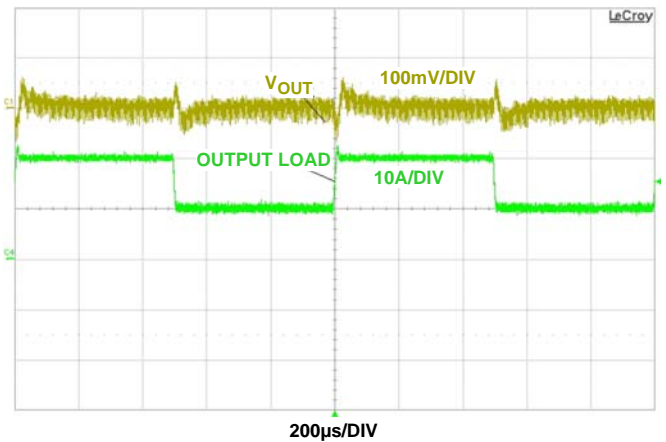

FIGURE 12. 10A-20A; 2A/µs AT CCM MODE

Application Note 1881

Typical Performance Curves Unless otherwise specified, the input voltage is 12V. (Continued)

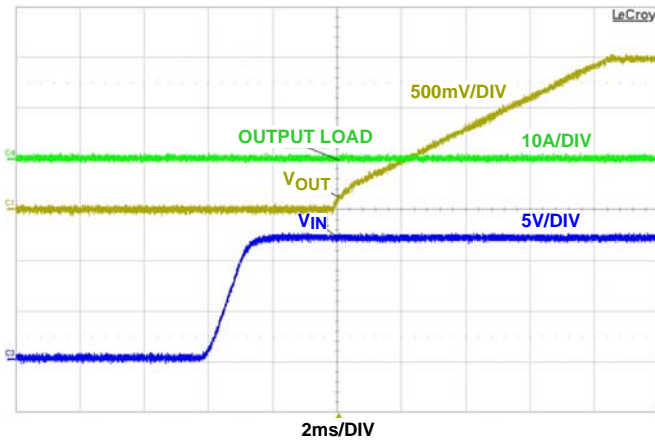

FIGURE 13. START-UP AT 0A LOAD CONDITION

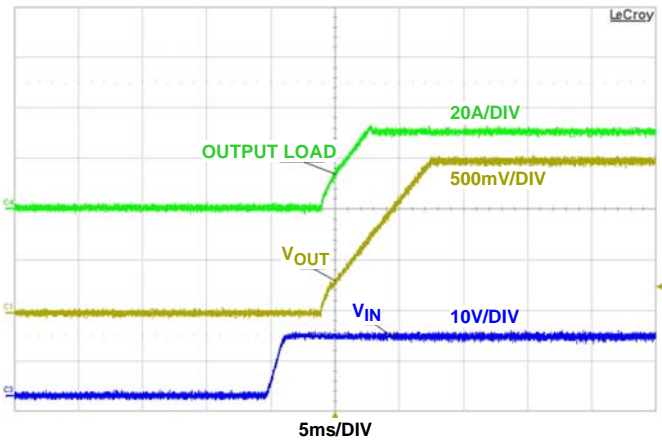

FIGURE 14. START-UP AT 30A LOAD CONDITION

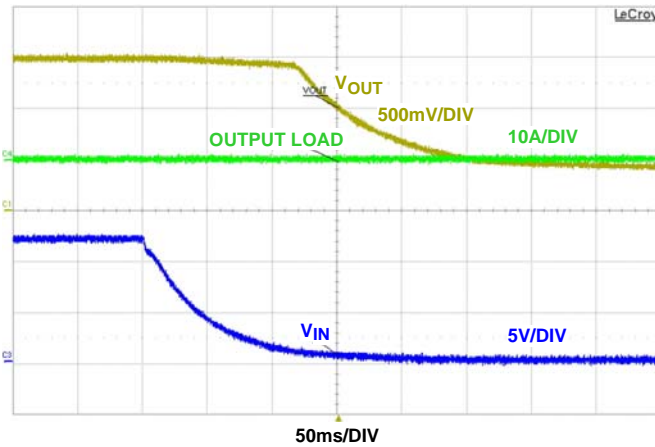

FIGURE 15. SHUTDOWN AT 0A LOAD CONDITION

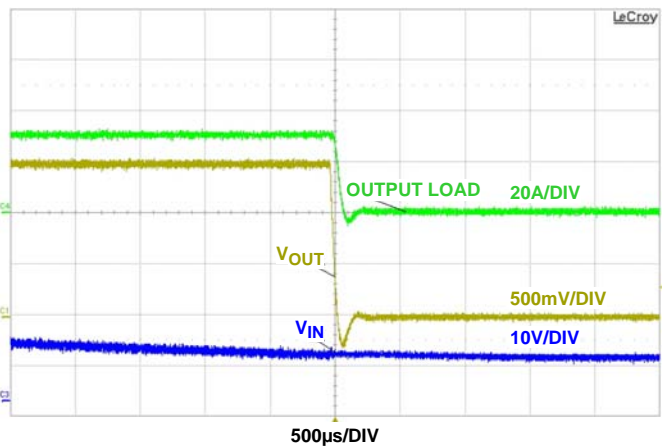

FIGURE 16. SHUTDOWN AT 30A LOAD CONDITION

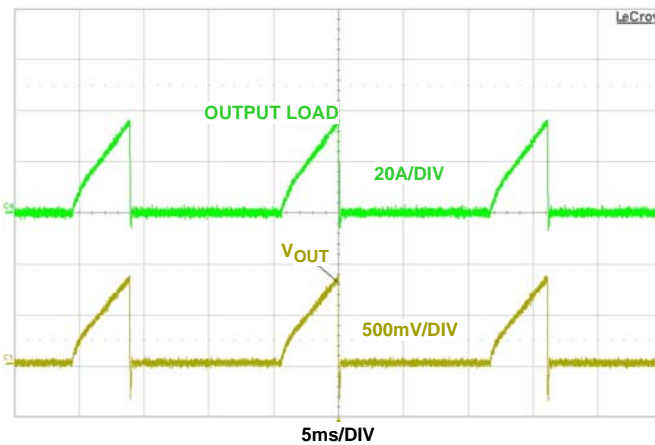

FIGURE 17. OCP AT 34A LOAD

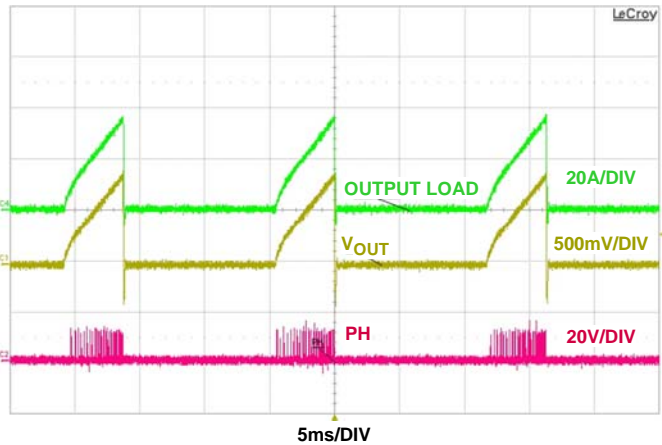
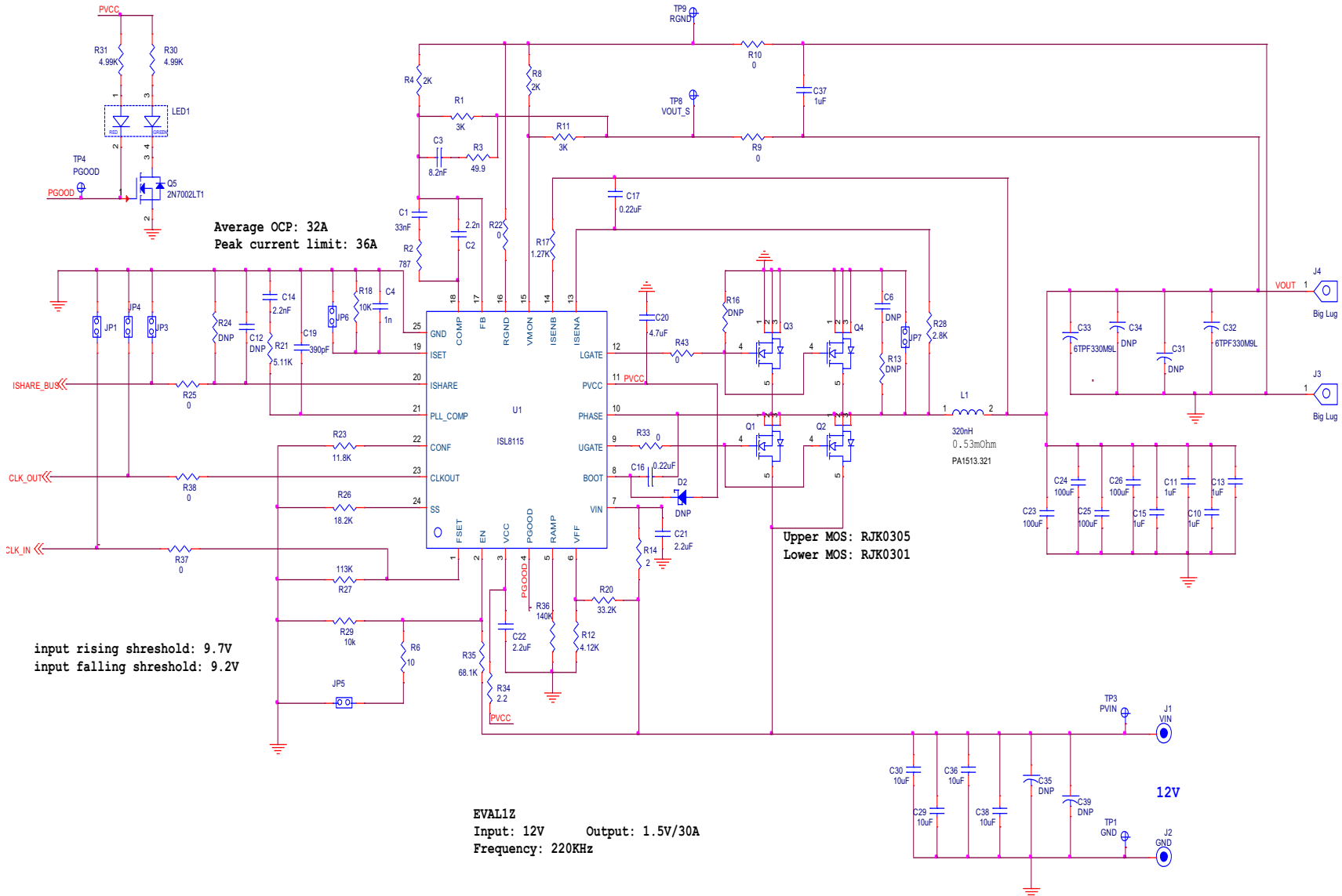

FIGURE 18. SHORT PROTECTION

Schematic



Application Note 1881

Bill of Materials

| QTY | REFERENCE | VALUE | DESCRIPTION | PART # | VENDOR |
|-----|---------------------------------------|---------------|----------------------------------|---------------------|--------------------|
| 1 | C1 | 33nF | CAP CER 0.033μF 50V 10% X7R 0603 | Generic | Generic |
| 1 | C2 | 2.2n | CAP CER 2200pF 50V 5% NPO 0603 | Generic | Generic |
| 1 | C3 | 8.2n | CAP CER 8200pF 50V 5% NPO 0603 | Generic | Generic |
| 1 | C4 | 1n | CAP CER 1000pF 50V 5% NPO 0603 | Generic | Generic |
| 5 | C6, C12, R13, R16, R24 | DNP | | Generic | Generic |
| 5 | C10, C11, C13, C15, C37 | 1μF | CAP CER 1μF 10V 10% X5R 0603 | Generic | Generic |
| 1 | C14 | 2.2nF | CAP CER 2200pF 50V 5% NPO 0603 | Generic | Generic |
| 2 | C16, C17 | 0.22μF | CAP CER 0.22μF 16V 10% X7R 0603 | Generic | Generic |
| 1 | C19 | 390pF | CAP CER 390pF 50V 5% NPO 0603 | Generic | Generic |
| 1 | C20 | 4.7μF | CAP CER 4.7μF 6.3V 10% X5R 0805 | Generic | Generic |
| 1 | C21 | 2.2μF | CAP CER 2.2μF 25V 10% X7R 1210 | C3225X7R1E225K/1.60 | TDK |
| 1 | C22 | 2.2μF | CAP CER 2.2μF 6.3V 20% X5R 0603 | Generic | Generic |
| 4 | C23, C24, C25, C26 | 100μF | CAP CER 100μF 6.3V 20% X5R 1210 | C3225X5R0J107M250AC | TDK |
| 4 | C29, C30, C36, C38 | 10μF | CAP CER 10μF 50V 10% X5R 1206 | C3216X5R1H106K160AB | TDK |
| 2 | C31, C34 | DNP | CAP TANT 330μF 6.3V 20% 2917 | 6TPF330M9L | Panasonic |
| 2 | C32, C33 | 6TPF330M9L | CAP TANT 330μF 6.3V 20% 2917 | 6TPF330M9L | Panasonic |
| 2 | C35, C39 | DNP | CAP OS-CON 270μF 16V | 16SEPC270MX | Panasonic |
| 1 | D2 | DNP | DIODE SCHOTTKY 40V SOD123 | | |
| 6 | JP1, JP3, JP4, JP5, JP6, JP7 | Jumper | JUMPER PLUG 2POS DOUBLE ROW | XG8T-0231 | Omron |
| 1 | J1 | VIN | POST BINDING BANANA INSULATED RE | 111-0707-001 | Johnson Components |
| 1 | J2 | GND | POST BINDING BANANA INSULATED BL | 111-0703-001 | Johnson Components |
| 2 | J3, J4 | Big Lug | CONN- Big Lug TERMINAL POST | KPA8CTP | Burndy |
| 1 | LED1 | LXA3025IGC-TR | LED | LNJ162C3XRA | Panasonic |
| 1 | L1 | 320nH | INDUCT PWR 320NH SMD | PA1513.321 | Pulse |
| 2 | Q1, Q2 | RJK0305 | MOSFET N-CH 30V 30A 5-LFPAK | RJK0305DPB-00#J0 | Renesas |
| 2 | Q3, Q4 | RJK0328 | MOSFET N-CH 30V 30A 5-LFPAK | RJK0305DPB-00#J0 | Renesas |
| 1 | Q5 | 2N7002LT1 | MOSFET N-CH 60V 115mA SOT-23 | 2N7002LT1 | ON Semiconductor |
| 2 | R1, R11 | 3k | RES 3.00kΩ 1/10W 1% 0603 SMD | Generic | Generic |
| 1 | R2 | 787 | RES 787Ω 1/10W 1% 0603 SMD | Generic | Generic |
| 1 | R3 | 49.9 | RES 49.9Ω 1/10W 1% 0603 SMD | Generic | Generic |
| 2 | R4, R8 | 2k | RES 2.00kΩ 1/10W 1% 0603 SMD | Generic | Generic |
| 1 | R6 | 10 | RES 10Ω 1/10W 1% 0603 SMD | Generic | Generic |
| 8 | R9, R10, R22, R25, R33, R37, R38, R43 | 0 | RES 0.0Ω 1/10W JUMP 0603 SMD | Generic | Generic |
| 1 | R12 | 4.12k | RES 4.12kΩ 1/10W 1% 0603 SMD | Generic | Generic |
| 1 | R14 | 2 | RES 2.00Ω 1/4W 1% 1206 SMD | Generic | Generic |
| 1 | R17 | 1.27k | RES 1.27kΩ 1/10W 1% 0603 SMD | Generic | Generic |
| 2 | R18, R29 | 10k | RES 10kΩ 1/10W 1% 0603 SMD | Generic | Generic |
| 1 | R20 | 33.2k | RES 33.2kΩ 1/10W 1% 0603 SMD | Generic | Generic |
| 1 | R21 | 5.11k | RES 5.11kΩ 1/10W 1% 0603 SMD | Generic | Generic |

Application Note 1881

Bill of Materials (Continued)

| QTY | REFERENCE | VALUE | DESCRIPTION | PART # | VENDOR |
|-----|-----------|---------|-----------------------------------|-------------|----------|
| 1 | R23 | 11.8k | RES 11.8kΩ 1/10W 1% 0603 SMD | Generic | Generic |
| 1 | R26 | 18.2k | RES 18.2kΩ 1/10W 1% 0603 SMD | Generic | Generic |
| 1 | R27 | 113k | RES 113kΩ 1/10W 1% 0603 SMD | Generic | Generic |
| 1 | R28 | 2.8k | RES 2.8kΩ 1/10W 1% 0603 SMD | Generic | Generic |
| 2 | R30, R31 | 4.99K | RES 4.99kΩ 1/10W 1% 0603 SMD | Generic | Generic |
| 1 | R34 | 2.2 | RES 2.2Ω 1/10W 1% 0603 smD | Generic | Generic |
| 1 | R35 | 68.1k | RES 68.1kΩ 1/10W 1% 0603 SMD | Generic | Generic |
| 1 | R36 | 140k | RES 140kΩ 1/10W 1% 0603 SMD | Generic | Generic |
| 1 | TP1 | GND | Test point | SPCJ-123-01 | Jolo |
| 1 | TP3 | PVIN | Test point | SPCJ-123-01 | Jolo |
| 1 | TP4 | PGOOD | Test point | SPCJ-123-01 | Jolo |
| 1 | TP8 | VOUT_S | Test point | SPCJ-123-01 | Jolo |
| 1 | TP9 | RGND | Test point | SPCJ-123-01 | Jolo |
| 1 | U1 | ISL8115 | Sync Buck PWM Controller 24Ld QFN | ISL8115FRTZ | Intersil |

Assembly Drawing

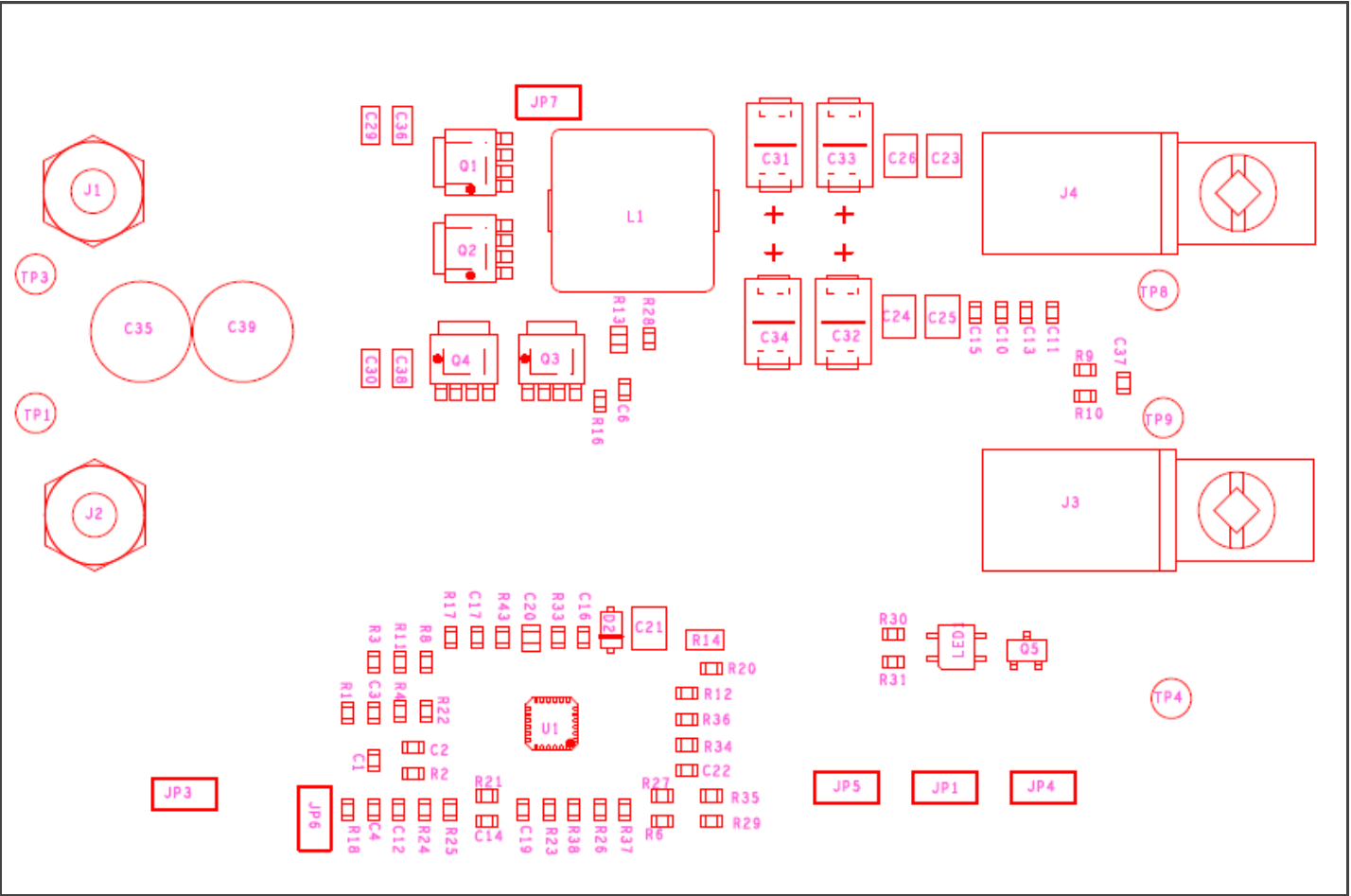

PCB Layout

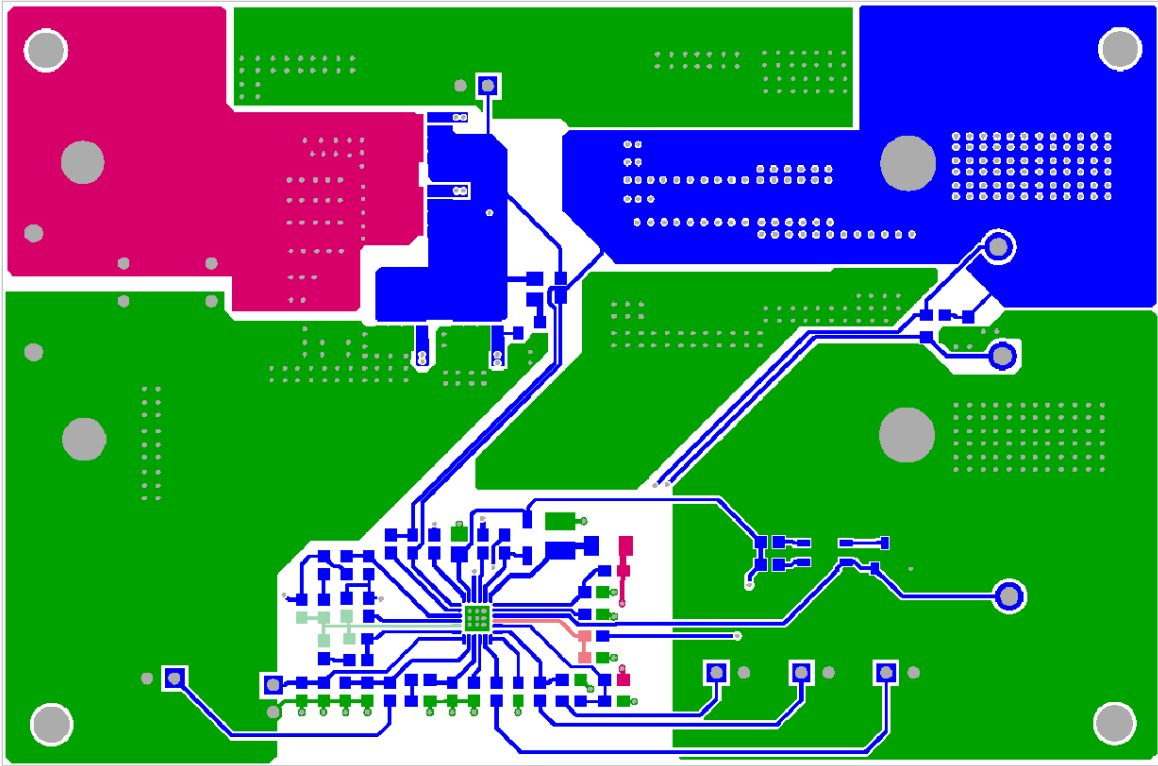

FIGURE 19. TOP LAYER

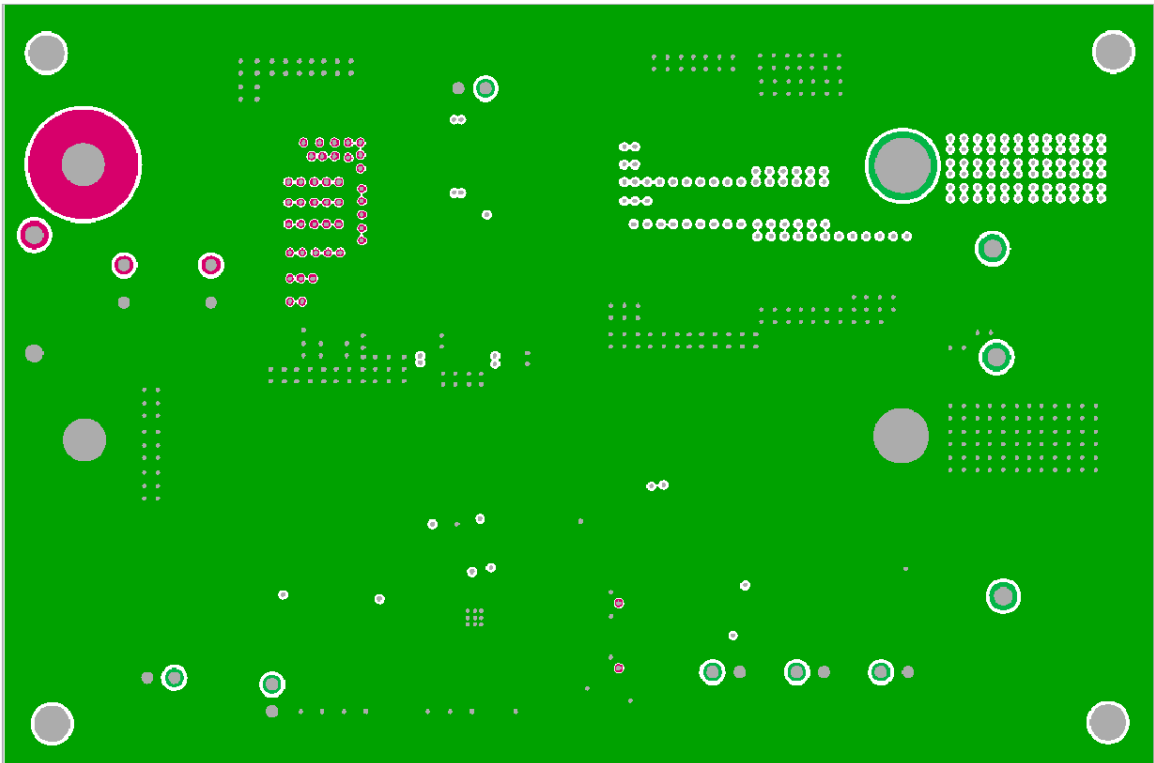

FIGURE 20. LAYER 2

PCB Layout (Continued)

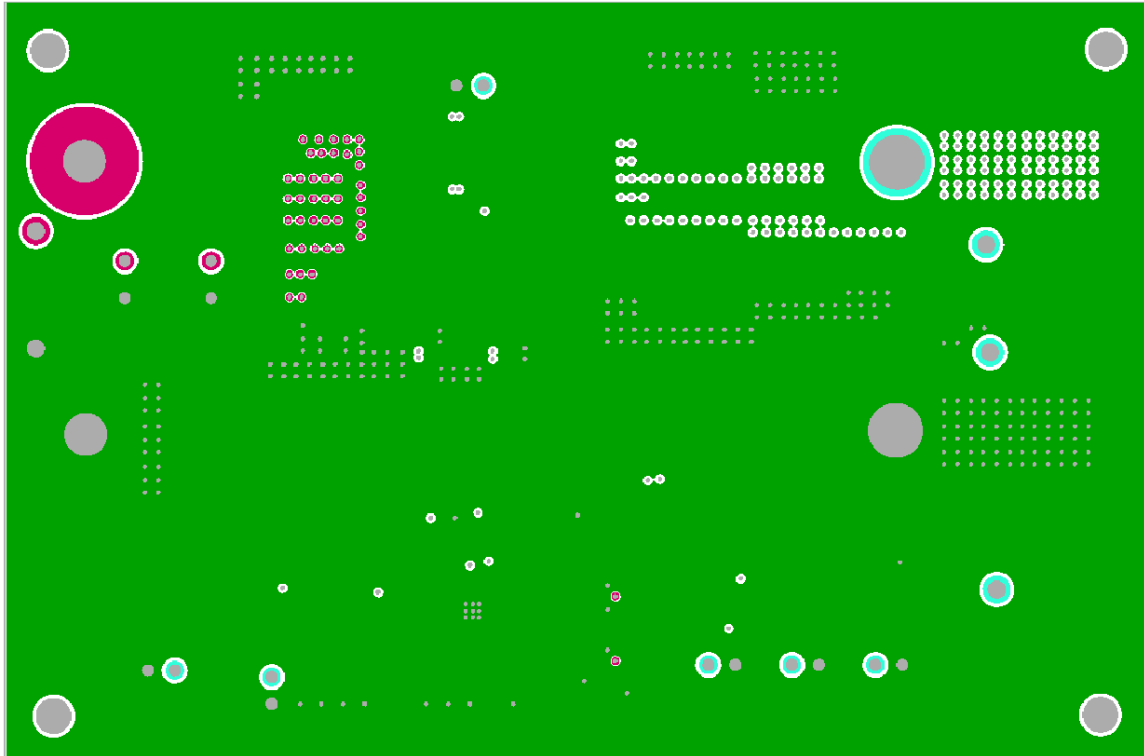

FIGURE 21. LAYER 3

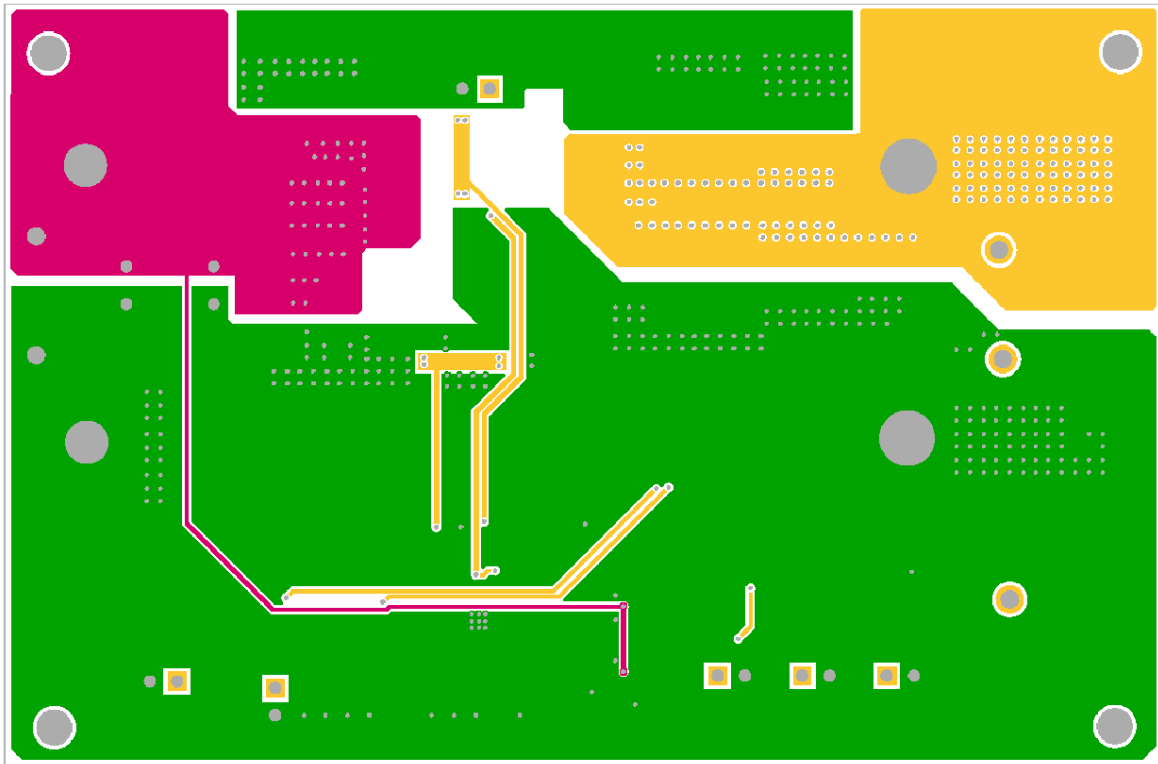

FIGURE 22. LAYER 4

Intersil Corporation reserves the right to make changes in circuit design, software and/or specifications at any time without notice. Accordingly, the reader is cautioned to verify that the Application Note or Technical Brief is current before proceeding.

For information regarding Intersil Corporation and its products, see www.intersil.com