

THIS DOCUMENT IS THE PROPERTY OF
KEYSTONE ELECTRONICS CORP. AND
SHALL NOT BE REPRODUCED, DISTRIBUTED
OR USED AS A BASIS FOR MANUFACTURE
WITHOUT PRIOR WRITTEN PERMISSION
FROM KEYSTONE ELECTRONICS CORP.

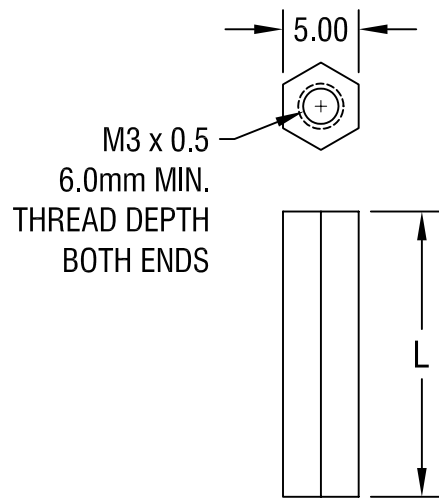

| PART NO. | 'L' DIM. |
|----------|----------|
| 25514 | 20.00 |
| 25515 | 25.00 |

NOTE:

1. ALL DIMENSIONS ARE IN MILLIMETERS

| KEYSTONE ELECTRONICS CORP. | | | |
|-----------------------------------|----------------------|--------|--------------------|
| ASTORIA, N.Y. 11105-2017 | | | |
| PART NAME | | | |
| 5mm THREADED HEX STANDOFF | | | |
| MATERIAL | | | |
| NYLON 6/6 | | | |
| FINISH | | DRN BY | DATE |
| - | | BOONE | 7.18.06 |
| | | APP'D | SCALE |
| | | LN | 2X |
| TOLERANCES | INCH [MM] | CODE | DWG NO. |
| DECIMAL | \pm [± 0.40] | C/M | 25514-25515 |
| ANGULAR | $\pm 1^\circ$ | | |
| UNLESS OTHERWISE SPECIFIED | | | |

| DATE | DESCRIPTION | REV. |
|------|-------------|------|
| | | |